

A.S.F. enterprise
TOSCAN STUCCHI



Catalogo Generale
General Catalogue

Stucchi decorativi da interno ed esterno
prodotti in legno e collanti

*Decorative stuccos for interiors and exteriors,
wood products, and adhesives*



A.S.F. enterprise
TOSCAN STUCCHI

L'arte dello Stucco *nel cuore della Toscana*

Il marchio ASF Enterprise prodotti Toscan Stucchi è sinonimo di una realtà aziendale competitiva nel settore dei manufatti in gesso e stucchi decorativi, ed è oggi un punto di riferimento per tutti gli operatori del settore, dai rivenditori agli utilizzatori.

L'azienda, nata oltre trenta anni fa, ha iniziato dopo alcuni anni di attività la produzione della linea legno e successivamente quella dei prodotti specifici in gesso idrorepellente e malta cementizia, per la realizzazione e il ripristino degli ambienti in esterno.

I tratti peculiari dell'azienda sono da individuare principalmente nel rispetto per la tradizione legata a questo antico mestiere, la continua voglia di ampliare il proprio raggio di azione e l'interesse alle innovazioni e ai miglioramenti produttivi. È da questa filosofia di lavoro, infatti, che sono maturate le qualità che fanno della A.S.F. Enterprise un marchio di garanzia: estro artistico, grande cura dei particolari, spirito di ricerca e innovazione, selezione della mano d'opera qualificata nella produzione e nel montaggio; in questo caso vengono formate squadre specializzate che operano sotto la supervisione dei responsabili del progetto, direttamente su posto sia in Italia che all'estero.

Alla base del processo di produzione c'è l'unione di profonde competenze sia artistiche che tecniche: dai disegni progettuali si sviluppano gli stampi degli articoli destinati alla produzione in serie o alla realizzazione di specifici lavori di restauro o ricostruzione.

La solidità della ASF Enterprise, nel rapporto fiduciario con il cliente, non è solo il risultato di scelte e operatività sensibili al mercato, ma anche la volontà di tradurli in vantaggio competitivo per il committente. Il sito industriale a Colle di Val D'Elsa, infatti, è in costante evoluzione e l'accresciuta flessibilità e capacità produttiva ne garantiscono la massima qualità di risultato sia in termini di prodotti che di servizio.

Con questa pubblicazione si è voluto raccogliere l'intera produzione della ASF Enterprise in un unico catalogo, perchè tutte le informazioni tecniche e di immagine possano essere utilizzate dai rivenditori agevolando il loro rapporto con la clientela, e dagli operatori del settore per lavorare meglio e con un supporto adeguato.



The art of stuccowork in the heart of Tuscany



The ASF Enterprise "Toscan Stucchi" brand name is synonymous with competitive decorative plaster and stuccowork manufacturing that, today, is a point of reference for all sector operators, from retailers to users.

The company, founded more than thirty years ago, began production of the "Wood Line" a few years later and the specific products in water-repellent plaster and cement mortar products for construction and renovation of exteriors shortly thereafter.

The principal qualities that set the company apart are respect for the tradition of this ancient craft, enthusiasm for their work and the desire to expand the product range, and interest in innovation and product/production improvements. This basic working philosophy has generated the characteristics that make ASF Enterprise a brand offering a host of guarantees: artistic flair, great attention to detail, a spirit of research and innovation, a selected, qualified workforce for production and assembly. ASF Enterprise's workers are in fact organized into specialized teams that work under the supervision of project managers directly on-site, both in Italy and abroad. The production process unites profound artistic knowledge and fine technical skills: specially-created design drawings are the basis for the molds for articles destined for series production or for realization of specific restoration or reconstruction jobs.

ASF Enterprise's solidity and fiduciary relationship with their customers is the result not only of market-oriented decisions and production but also of a will to translate these orientations into competitive advantages for clients. The Colle Val d'Elsa industrial site is a constantly evolving reality, where every boost in versatility and production capacity translates into top results in terms of both products and services.

This publication brings together the entire ASF Enterprise product range in a single catalogue, to offer all the technical information and images needed by retailers for promoting relations with their clientele, and by sector operators for working in the best possible manner, with the aid of an adequate support.





Stand ASF Enterprise
SAIE Bologna
The ASF Enterprise stand at the
SAIE Bologna trade fair



Realizzazione elementi in gesso su
progetto
Manufacture of made-to-order plaster
elements

pagina seguente
Four Seasons Hotel - Firenze
salotto della suite
Next page
Four Seasons Hotel - Florence
the suite living room

Realizzazione modelli su progetto - Creation of special models to client designs







Four Seasons Hotel - Firenze - ingresso ristorante
Four Seasons Hotel - Florence - entrance to the restaurant

Ristorante da Iva - Bucchianico (CH)





Abitazione privata - Barberino del Mugello (FI)
Private home - Barberino del Mugello (FI)



Ristorante da Iva - Bucchianico (CH)



Villa privata - Rossano (CS) assistenza e fornitura società
F.M. Centro Colori Corigliano Scalo (CS)
*Private villa - Rossano (CS) assistance and supply by
F.M. Centro Colori - Corigliano Scalo (CS)*

Villa Liberty - Lucca







Ristorante da Iva - Bucchianico (CH) salone realizzato da Arredo Casa Guardiagrele (CH)
Ristorante da Iva - Bucchianico (CH) hall decorated by Arredo Casa Guardiagrele (CH)

A Restauro

La ASF Enterprise ha approfondito nel corso della sua esperienza le proprie conoscenze relative al restauro di ambienti interni ed esterni, di ville, residenze, palazzi storici e opere anche di grande importanza storico architettonica.

Particolare menzione merita l'opera di ricostruzione delle sale Sant'Andrea e Sant'Alessandro del Gran Palazzo del Cremlino di Mosca, orgogliosa testimonianza dell'esperienza e delle capacità realizzative dell'azienda.

Negli anni l'azienda si è arricchita dell'apporto di maestranze qualificate e specializzate a cui si affiancano sempre consulenti tecnici e artistici con un comune obiettivo: ottenere risultati di grande qualità nel rispetto del valore storico e artistico che questi beni rappresentano. Tutte le commesse vengono affrontate con serietà e professionalità e diventano espressione di un patrimonio di abilità ragionate e vissute, nel dialogo e nel continuo confronto con committenti, progettisti e Soprintendenze.

Una delle fasi fondamentali del lavoro è l'analisi del degrado, attuata attraverso indagini in loco ed in laboratorio; si procede così all'accertamento dei materiali originari e del loro stato conservativo. Da qui nasce il progetto di restauro vero e proprio che guiderà l'effettiva esecuzione degli interventi che saranno costantemente verificati e documentati. Le tecniche di esecuzione vanno dalla selezione dei materiali per le caratteristiche necessarie al recupero e ripristino di bassorilievi, finiture di pregio e decorazioni pittoriche.

Le competenze specifiche, l'alto grado di professionalità e il continuo aggiornamento permettono di eseguire lavori in qualsiasi tipo di ambiente, fino a realizzare restauri di alto livello qualitativo, nel pieno rispetto delle opere su cui si interviene.

1 - Sala Sant' Alessandro Gran Palazzo del Cremlino - Mosca

Saint Alexander Hall in Moscow's Great Kremlin Palace

2 - Particolare di un prototipo in creta dello stemma

Detail of a clay prototype for the coat-of-arms

3 - Avanzamento dei lavori sul cantiere

Work in progress



2

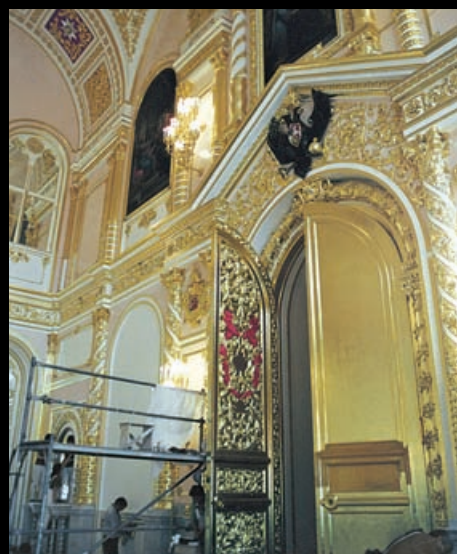

3

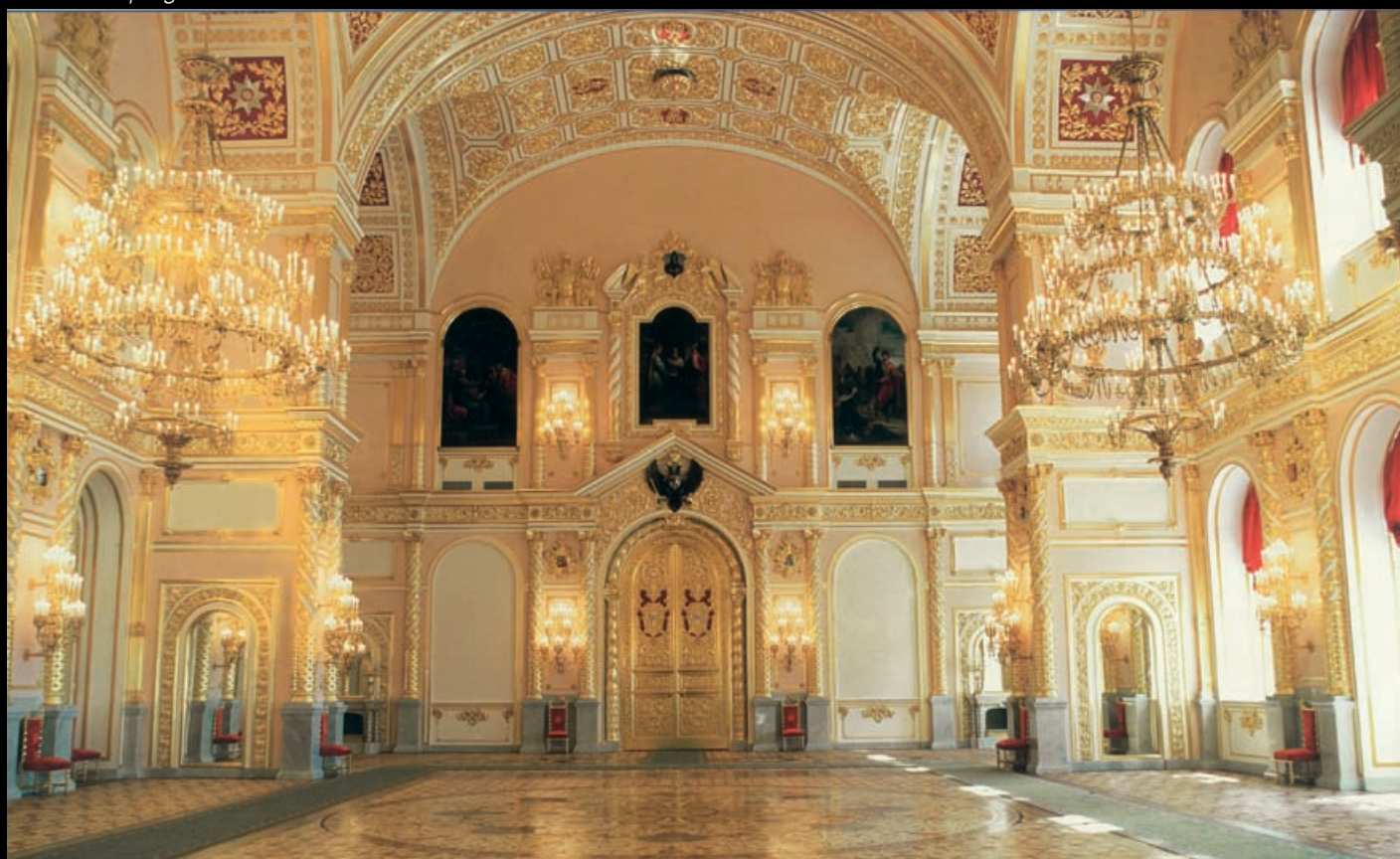

1

Restoration



4



5

Over the years, ASF Enterprise has accrued exhaustive knowledge concerning restoration of interiors and exteriors, villas, residences, historic buildings, and many works of great historic architectural importance.

Special mention should go to the reconstruction of the Saint Andrew and Saint Alexander halls of the Great Kremlin Palace of Moscow, proud testimony to the company's experience and project skills.

Over the years, the company has benefited from the contribution of qualified, skilled workers, always flanked by technical and artistic consultants and all inspired by a single idea: to obtain high-quality results in respect of the historic and artistic value of the assets they restore. Every ASF Enterprise job is seen through with commitment and professional poise, and each becomes yet another expression of a wealth of skills acquired through study, experience, and ongoing dialogue and joint efforts involving clients, designers, and the fine arts services.

One of the fundamental phases of the work is analysis of degradation, conducted on-site and in the laboratory to ascertain the composition of the original materials and their true state of preservation. Then comes the restoration project per se, the blueprint for conducting the actual work, which in turn is constantly verified and documented. Realization techniques range from selection of materials on the basis of the needed characteristics to recovery and integration/restoration of bas-reliefs, precious finishes, and pictorial decoration.

Specific skills, a professional approach, and refresher training make it possible for ASF to conduct high-quality restoration/construction work in any type of environment, in full respect of the intrinsic value of the original works.

4 - Interventi effettuati sulla volta
Work on the ceiling

5 - Preparazione dorature a terra della Sala Sant' Andrea
Preparation of gilded elements for Saint Andrew Hall

6 - Volta ovale della Sala Sant' Alessandro
Oval vault of Saint Alexander Hall

6





2



Esempi di realizzazioni di restauro
Examples of restoration's realization

- 1 - soffitto a volta con cassettonato
vaulted coffered ceiling
- 2 - particolare del soffitto cassettonato
detail of the coffered ceiling
- 3 - cantiere durante gli interventi sulla volta
worksite during work on the ceiling vault
- 4 - particolare del soffitto
detail of the ceiling
- 5 - particolare dell'ingresso
detail of the entranceway

1

3





4



5



6



7



8



9



Esempi di realizzazioni di restauro
Examples of restoration's realization

6 - 7 - 8 ristrutturazione in corso dei bagni
bathroom refurbishing work in progress

9 - particolare delle mensole in gesso del sotto terrazzo
detail of the plaster corbels below the terrace

Four Seasons Hotel - Firenze - zona nobile
Four Seasons Hotel (FI) - a detail of the historic palazzo area

Villa Le Maschere - Barberino del Mugello (FI)

Lavori di consolidamento degli stucchi e reintegro eseguiti per conto della ditta SANSONE SRL.

Sotto alcuni esempi con locali finiti anche nella parte pittorica e decorativa, sapientemente eseguite dalla ditta SANSONE SRL, che valorizza il lavoro della nostra azienda.

(traduzione inglese) Lavori di consolidamento degli stucchi e reintegro eseguiti per conto della ditta SANSONE SRL.

Sotto alcuni esempi con locali finiti anche nella parte pittorica e decorativa, sapientemente eseguite dalla ditta SANSONE SRL, che valorizza il lavoro della nostra azienda.



1

1 - restauro del soffitto di una camera
durante la lavorazione
*restoration of the ceiling of a guest
room during work*



2

2 - a lavoro finito
finished ceiling



3



4



5

3 - particolare angolo di un salone prima del restauro

detail of a corner of a hall before restoration

4 - rilievi effettuati nel corso del lavoro

surveys during the course of work

5 - avanzamento del ripristino

restoration work in progress

6 - ambiente nella parte conclusiva del lavoro

the room during the conclusive phase of work

6





7



8



Villa Le Maschere - Barberino del Mugello (FI)

7 - particolare di salone condizione iniziale
detail of the hall before restoration

8 - particolare salone in corso d'opera
detail of the hall during work

9 - ambiente nella parte conclusiva del lavoro
the hall during the conclusive phase of work

10 - particolare capitello e lesena ad inizio lavoro
detail of a capital and pilaster before restoration

11 - fase conclusiva del lavoro
conclusive phase of the work



10

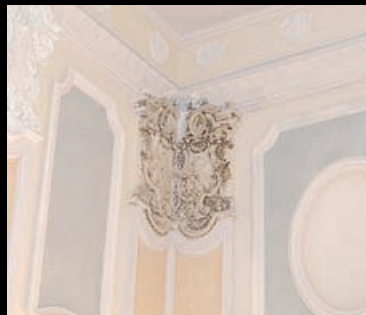

11

12 - operazione di consolidamento degli intonaci e dei decori
consolidation of the wall plasterwork and the decoration

13 - lavorazione e ripristino cornice
preparation and restoration of the frame

14 - Cappella della villa con stucchi e affreschi
the villa's chapel with stuccos and frescoes



12



13

14



Indice - Contents

Linea
Gesso

Introduzione / <i>Introduction</i>	20
Sgusci / <i>Coving Elements</i>	26
Cornici / <i>Frames</i>	44
Luci Diffuse / <i>Lighting Coves</i>	60
Angoli, Spigoli, Mezzerie, Centine <i>Inside Corners, Outside Corners, Corners, Dividers, Curves</i>	64
- Angoli, Spigoli / <i>Inside Corners, Outside Corners</i>	66
- Tabella abbinamenti con le cornici <i>Table of compositions with frames</i>	70
- Angoli, Mezzerie, Centine <i>Corners, Dividers, Curves</i>	71
Rosoni / <i>Ceiling Rosettes</i>	80
- Rosoni a scomparsa <i>Embossed-effect ceiling rosettes</i>	106
Bassorilievi / <i>Bas-reliefs</i>	112
Lesene / <i>Pilasters</i>	120
Basi e Capitelli / <i>Bases and Capitals</i>	128
Colonne / <i>Columns</i>	136
Semicolonne / <i>Half-columns</i>	144
Complementi d'Arredo <i>Decorating Complements</i>	150
Elementi Vari / <i>Various Elements</i>	162
- Angoli Liberi / <i>Free Corners</i>	164
- Fregi / <i>Freizes</i>	166
- Mensole / <i>Corbels</i>	172
- Rosette / <i>Rosettes</i>	175
- Nicchie / <i>Niches</i>	176
- Cassettonati / <i>Coffering Elements</i>	178
- Componibili / <i>Modular Elements</i>	182
- Soffitti / <i>Ceilings</i>	183
- Cerchi e Semicerchi / <i>Circles and Semicircles</i>	190
- Rivestimenti / <i>Cladding</i>	193
Anticati, Decorati, Satinati <i>Antique Finishes, Decorative Finishes, Satin Finishes</i>	204
- Anticati / <i>Antique Finishes</i>	206
- Decorati / <i>Decorative Finishes</i>	214
- Satinati / <i>Satin Finishes</i>	224

Linea *Legno*

Introduzione / <i>Introduction</i>	234
Anticati / <i>Antique Finishes</i>	238
Battiscopa in Ayous verniciato <i>Skirting boards in varnished Ayous</i>	242
Battiscopa e Paraspigoli in MDF rivestito <i>Skirting boards and corner guards in covered MDF</i>	245
Battiscopa e Paraspigoli Impiallacciati <i>Veneered skirting boards and corner guards</i>	246
Battiscopa Impiallacciati <i>Veneered skirting boards in varnished woods</i>	247
Paraspigoli in Ayous verniciato <i>Corner guards in varnished Ayous</i>	248
Coprimarmo in Ayous verniciato <i>Edging boards in varnished Ayous</i>	249
Liste da Porta / <i>Door frame Moldings</i>	250
- Ayous Verniciato / <i>Varnished Ayous</i>	
- Impiallacciato in Essenze Naturali <i>Veneered in Natural Essences</i>	
Cornici e Levangoli in Ayous <i>Frames and corner elements in Ayous</i>	251
Pino grezzo e verniciato <i>Unfinished and varnished Pine</i>	253
Laccati / <i>Lacquered Elements</i>	254
Profili grezzi in Ayous <i>Unfinished strip elements in Ayous</i>	256

Linea *Esterno*

Introduzione / <i>Introduction</i>	258
Battistero	266
Acanthocardia	270
Agorà	274
Archimede	278
Bolgheri	284
Fiorenza	288
Arianna	294
Egeo	298
Le Grete	302
Accessori / <i>Accessories</i>	306
- Architravi / <i>Architrave Frames</i>	312
- Architravi e Marcapiani <i>Architrave Frames and String-course Frame</i>	313
- Balaustra / <i>Balustrade</i>	314

Linea *Collanti*

Introduzione / <i>Introduction</i>	316
Collanti per Interni / <i>Adhesives for Interiors</i>	317
- Mastice Extra / <i>Extra Adhesive</i>	
- Mastice Normale / <i>Normale Adhesive</i>	
- Mastice Formula 2000 / <i>Formula 2000 Adhesive</i>	
Collanti per Esterni / <i>Adhesives for Exteriors</i>	317
- ES KOLL / <i>ES-KOLL Adhesive</i>	
- ID KOLL / <i>ID-KOLL Adhesive</i>	
- ES STUCK / <i>ES STUCK Adhesive</i>	
Il prodotto e la sua installazione <i>Product installation</i>	318

Linea
Gesso

Plaster Line



Il marchio ASF Enterprise è da sempre sinonimo di stucchi decorativi di qualità e di profonda conoscenza dell'arte e della storia di questo antico mestiere; la ricerca e le competenze specifiche sono la vera garanzia testimoniata anche dai risultati ottenuti in Italia ed all'estero.

La vasta gamma di articoli, da quelli della tradizione ai nuovi elementi dal design moderno, è in continuo sviluppo con nuove proposte frutto delle ricerche ed esperienze dirette sul campo. Grazie infatti alle attività di realizzazione e posa in opera delle maestranze dell'azienda, nascono nuove idee di prodotto che hanno poi ricaduta sulla produzione e danno vita ad articoli nuovi con maggiori possibilità applicative ed ulteriori interpretazioni per la progettazione e l'arredamento di interni.

I diversi comparti d'azienda, come modellisti, tecnici e scultori, si confrontano con il settore commerciale che controlla più da vicino le tendenze del mercato, per dare vita a nuovi ed ancor più stimolanti prodotti.

The ASF Enterprise brand has always been synonymous with high-quality decorative stuccos and profound knowledge of the art and history of this ancient craft; the research and specific competencies that are the true guarantees offered by the company support consistently excellent results in works in Italy and abroad.

The vast product range, from traditional articles to new elements featuring modern design, is constantly evolving to incorporate innovative proposals that reflect research and direct "on-the-ground" experience. Thanks, in fact, to the company workers' manufacturing and installation experience, new product ideas can develop and generate significant fallout for production, breathing life into new articles, for a constantly expanding range of applications and ever-new interpretations for interior design and furnishings.

As they create new and even more stimulating products, the different company departments, staffed by designers and model-makers, technicians and sculptors, constantly compare notes with the sales department, which keeps close watch over market trends.



1

Abitazione privata - Firenze

Private home - Florence

1 - particolare del soffitto con finiture oro - *detail of the ceiling with gilded trim*

2 - soffitto del salotto - *the ceiling of the living area*

2





1

Four Seasons Hotel - Firenze

Four Seasons Hotel - Florence

1 - scorcio camera da letto - *view of a guest room*

2 - scalinata zona nobile - *staircase of the historic palazzo area*

3 - particolare bagno - *detail of a bathroom*



2



3



Hotel Plaza - Pescara
lavori eseguiti dalla società Trifina srl e progettati dall'architetto Giorgio Baldantoni
work by Trifina srl to designs by Architect Giorgio Baldantoni

Hotel Alba - Pescara soffitto con stucchi, dipinti e decori in oro - *ceiling with stuccos and painted and gilded decoration*





1

Ristorante da Iva - Bucchianico (CH)

- 1 - ingresso del salone
entrance to the dining room
- 2 - particolare con lesene
detail with pilaster strips



2



Palazzo Presidenziale - Bata Nuova Guinea Equatoriale
Presidential Palace - Bata Equatorial Guinea

Show room Color' Shop - Casapulla (CE)



Linea
Gesso

Gypsum Line

Sgusci

Coving elements



Four Seasons Hotel - Firenze
Four Seasons Hotel - Florence



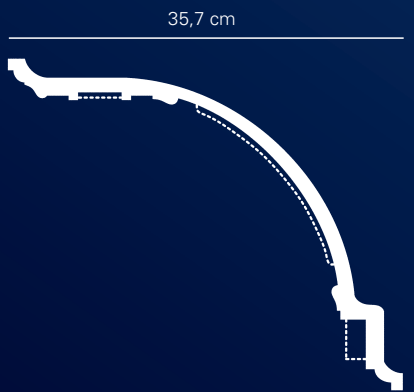
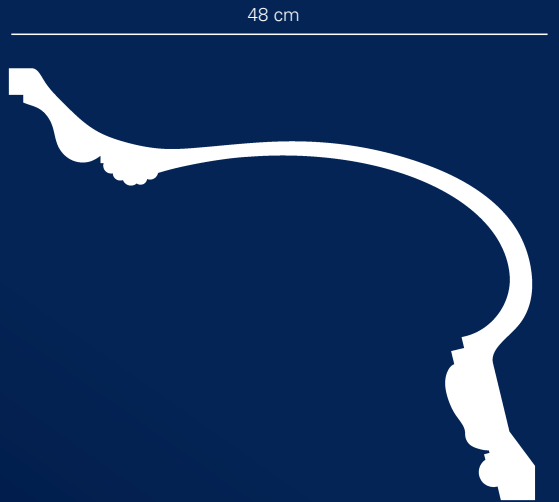

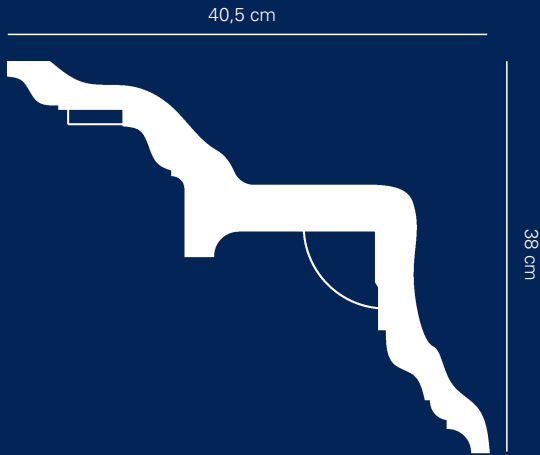

Art. 2168

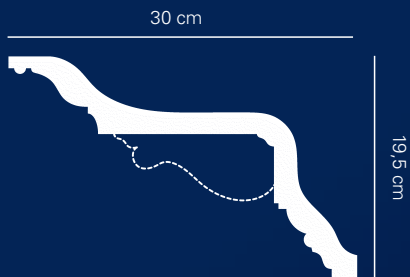

Art. 2277

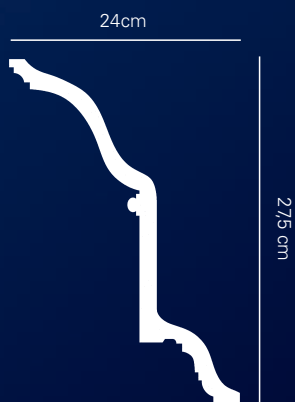

Art. 2200

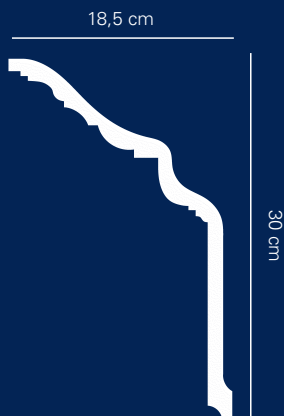

Art. 2282

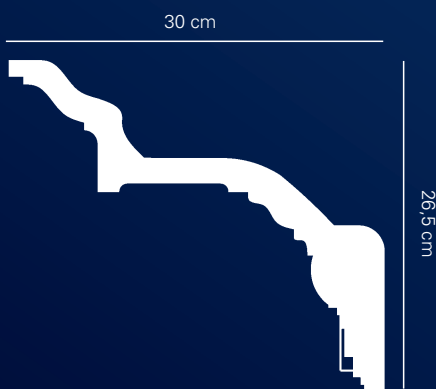

Art. 2101

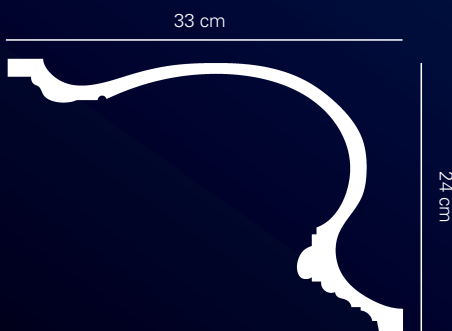

Art. 2254

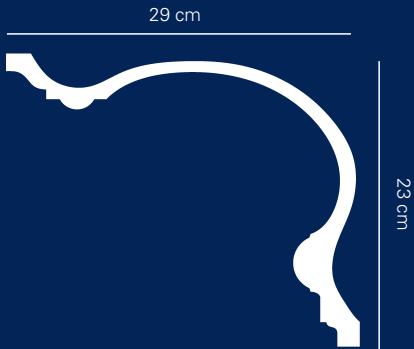

Art. 2223

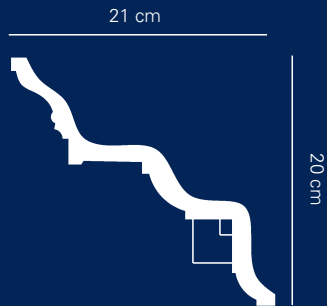

Art. 922



Art. 2267



Art. 2054

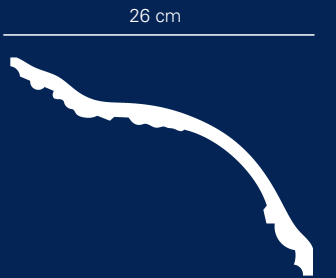

Art. 915



Art. 30/A



Art. 30/L



Art. 2234



Art. 2126

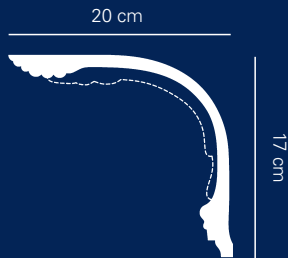

Art. 941

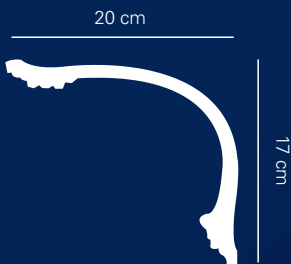

Art. 942

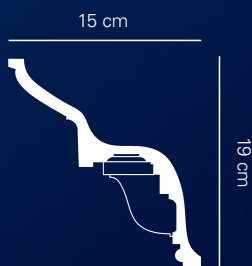

Art. 34/A

20 cm



12 cm



Art. 31/A

21 cm

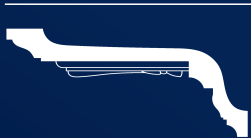

10 cm



Art. 2212

12 cm



14 cm



Art. 2151

11 cm



10 cm



Art. 33/A

8,5 cm



11 cm



Art. 630

9 cm



12,5 cm



Art. 929



Show room Color' Shop - Casapulla (CE)

Villa Privata - Yerevan Armenia
Private home



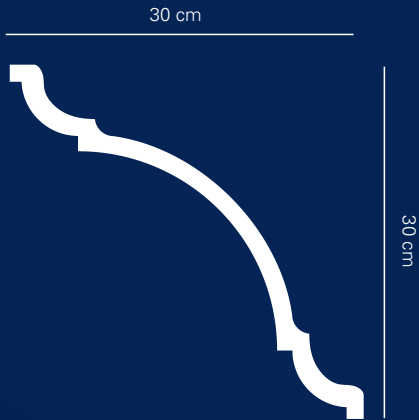

Art. 2259



Art. 186/B



Art. 2263



Art. 2182

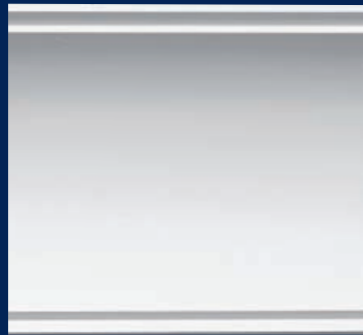
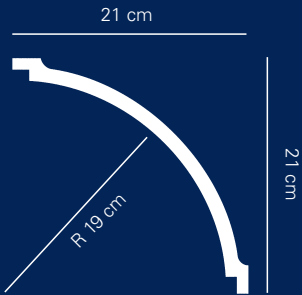

Art. 2013

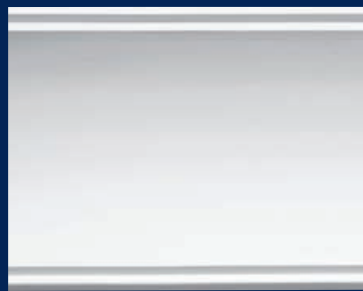
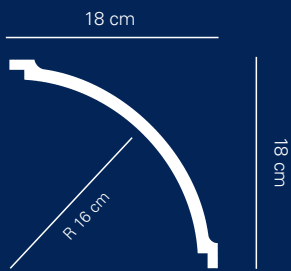

Art. 2147

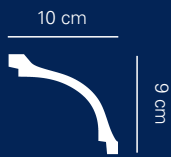

Art. 171

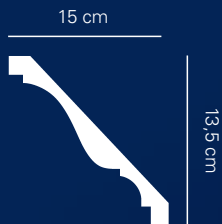

Art. 2206



Art. 927



Art. 2201



Art. 917



Art. 28/L



Art. 53/A

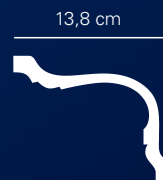

Art. 2150

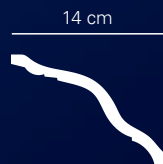

Art. 906



Art. 2269

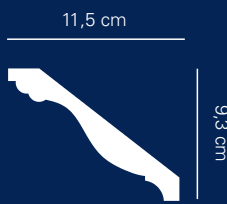

Art. 2246

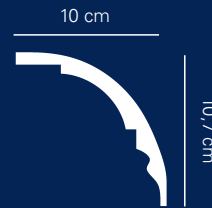

Art. 46/A



Art. 2202

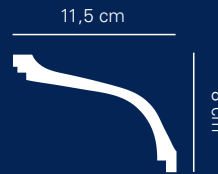

Art. 2111



Art. 45/A

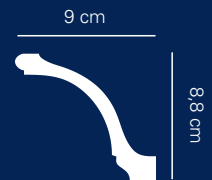

Art. 2102



Art. 2247

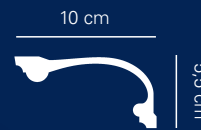

Art. 2232



Art. 2103



Art. 44/A



Art. 2207



Art. 916



Art. 905



Art. 2066

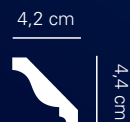

Art. 2113



Four Seasons Hotel - Firenze - *Four Seasons Hotel - Florence*

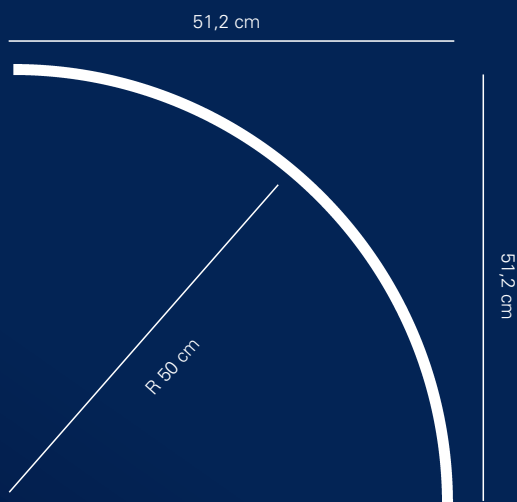

Art. 2237

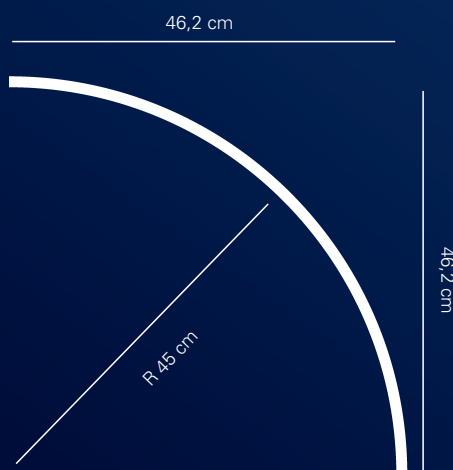

Art. 2236

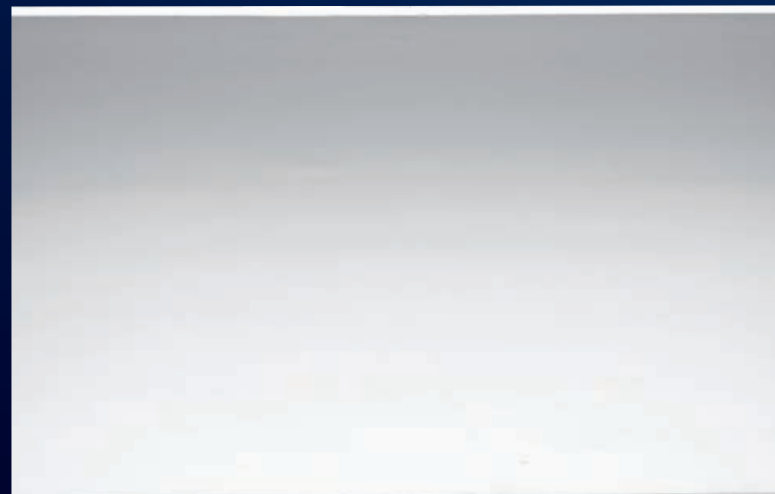
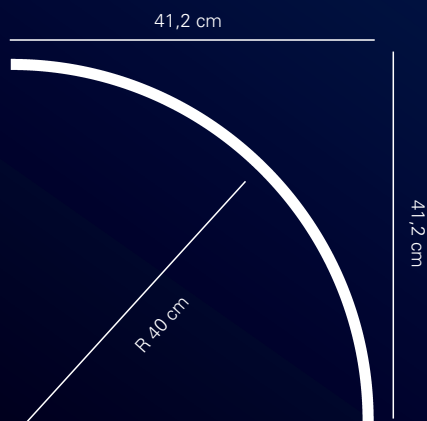

Art. 2225

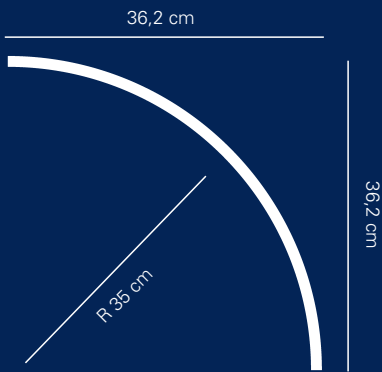

Art. 2226

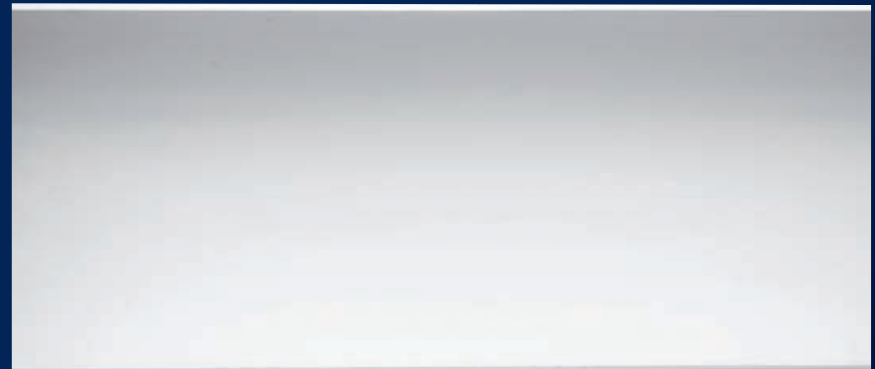
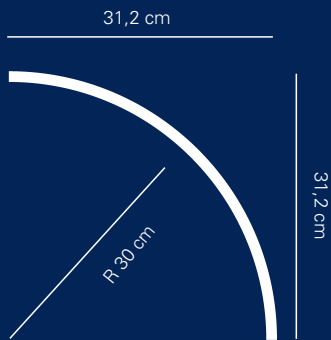

Art. 2227

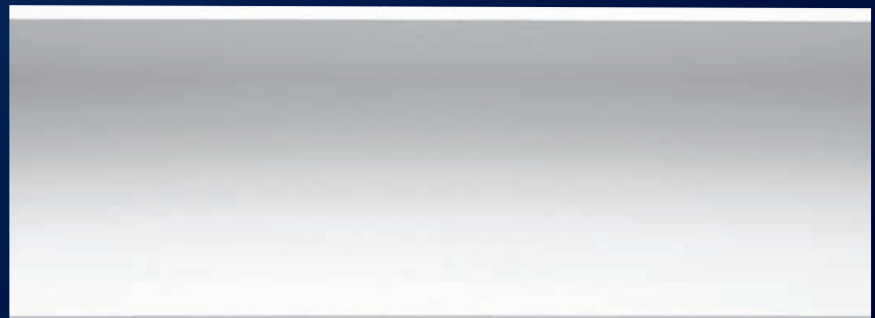
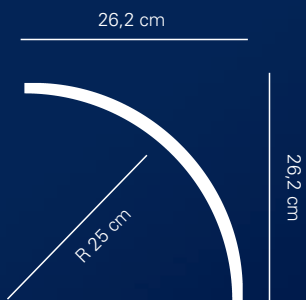

Art. 2076

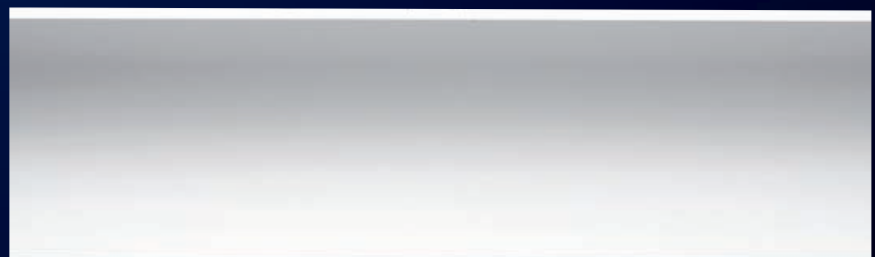
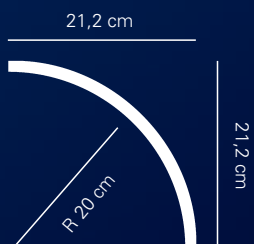

Art. 2075

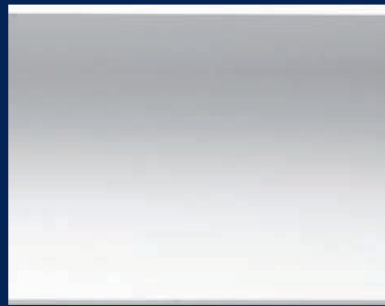
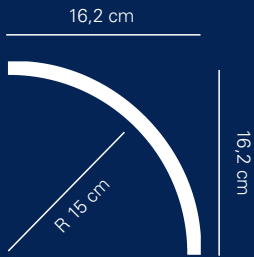

Art. 2064

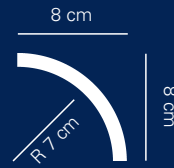

Art. 2170

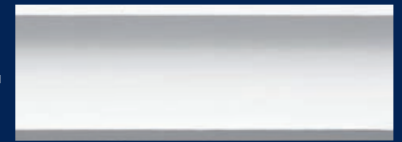
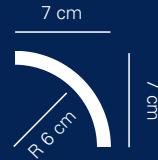

Art. 2019

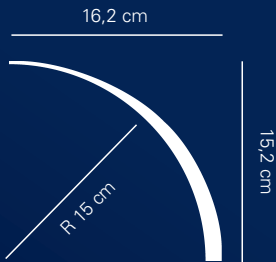

Art. 2064/Scomparsa
Effetto a scomparsa sul soffitto
Embossed effect on finished ceiling surface



Art. 2065

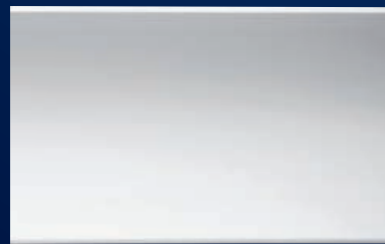
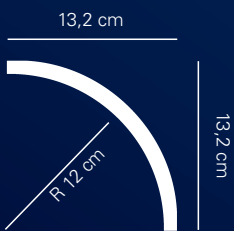

Art. 2190



Art. 2178

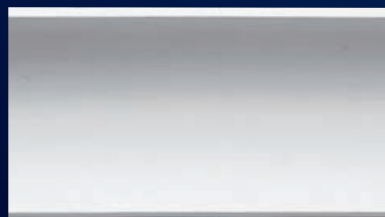
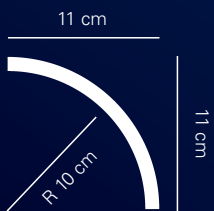

Art. 2077

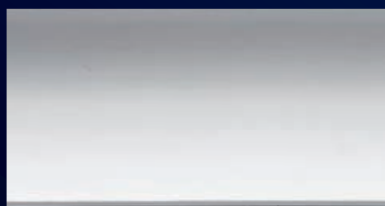
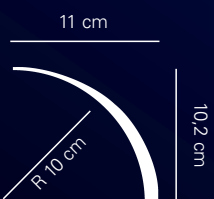

Art. 2077/Scomparsa
Effetto a scomparsa sul soffitto
Embossed effect on finished ceiling surface



Hotel Four Seasons - Firenze
Hotel Four Seasons - Florence



Hotel Cavalieri Hilton - Roma
Hotel Cavalieri Hilton - Rome

Ristorante da Iva - Bucchianico (CH)



Linea
Gesso

Gypsum Line

Cornici

Frames



Villa Privata - Yerevan Armenia
Private home

Hotel Four Seasons - Firenze
Hotel Four Seasons - Florence



4,7 cm



28,7 cm



Art. 2180

6,7 cm



24,5 cm



Art. 34/B

6,5 cm



23,5 cm



Art. 2127

5,5 cm



23,5 cm



Art. 903

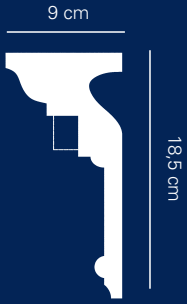

Art. 2209



Art. 34/C



Art. 173



Art. 2175



Art. 2181



Art. 618



Art. 604



Art. 617



Art. 2120



Art. 199

5,3 cm



34,5 cm



Art. 2155

16 cm



25,5 cm



Art. 2139

7,5 cm



21,8 cm

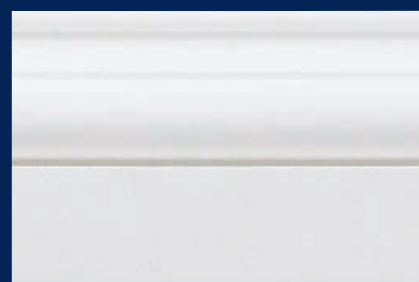

Art. 2049

7 cm



30 cm



Art. 2261

8,3 cm



16 cm



Art. 2062

6,5 cm



19,5 cm



Art. 2262

15 cm



15 cm



Art. 2088

6,5 cm



19 cm



Art. 2253

9 cm



9 cm

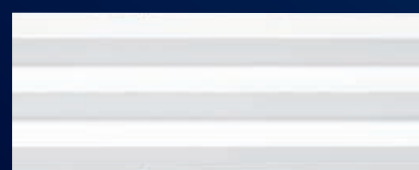

Art. 2087



Profili per spigoli

Corner profiles

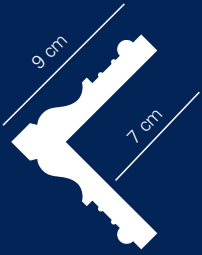

Art. 936



Art. 2042



Art. 2134



Art. 943



Art. 2144



Art. 2161

La linea ed il profilo di questi articoli sono particolarmente adatti per la realizzazione di porte e finestre per ambienti sia interni che esterni; in questo caso, su richiesta, possiamo produrli in materiale specifico idrorepellente.

The lines and profiles of these articles are especially suited for doors and windows for both interiors and exteriors; on request, we can supply articles for exteriors in specific water-repellent material.

2,3 cm



16,2 cm



Art. 2235

3,8 cm



15 cm



Art. 925

4 cm



11,5 cm

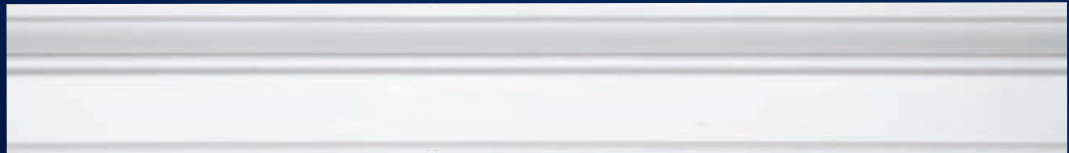

Art. 2159

3 cm



11 cm



Art. 2169

3 cm



9,3 cm



Art. 2137

1,5 cm



5,8 cm



Art. 2130



Questi prodotti si producono su richiesta anche in gessi speciali particolarmente resistenti per l'utilizzo come battiscopa

These products are available on order in special high-strength plasters for use as skirting boards.

1,5 cm



24,5 cm

4 cm



Art. 2153

1,5 cm



19,5 cm

2,7 cm

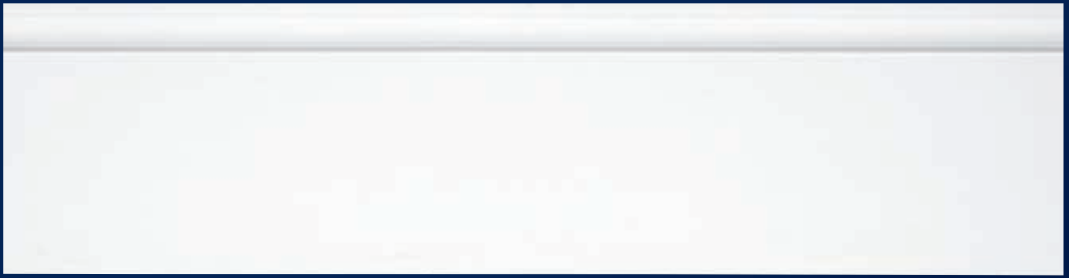

Art. 2167

0,8 cm



16 cm

2 cm

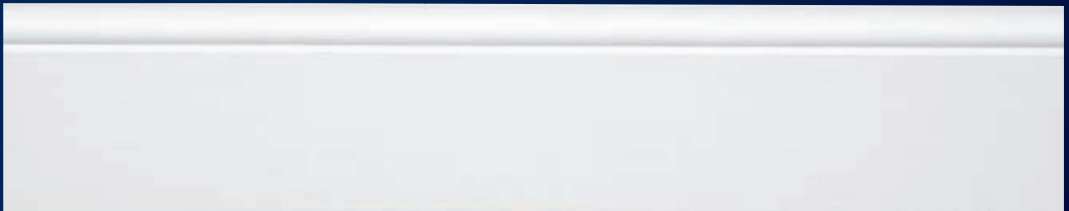

Art. 2093

0,8 cm



13 cm

2 cm

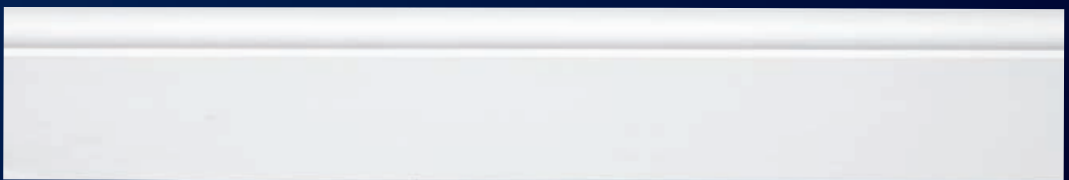

Art. 2198

1,8 cm



12,5 cm

3,5 cm



Art. 2214



Art. 2050



Art. 2183



Art. 2274



Art. 907



Art. 138



Art. 2104



Art. 912



Art. 52/A



Art. 28/B



Art. 920



Art. 155



Art. 50/A



Art. 2012



Art. 633



Art. 651/B



Art. 632



Art. 146



Art. 144



Art. 150



Art. 177



Art. 194



Art. 2171



Art. 2270



Art. 153



Art. 156



Art. 102



Art. 163



Art. 613



Art. 165



Art. 103



Art. 2124



Art. 2123



Art. 647/B



Art. 161



Art. 2074



Art. 195





Art. 2157



Art. 2204



Art. 2203



Art. 2276



Art. 2006



Art. 2248



Art. 43/A



Art. 2118



Art. 48/A



Art. 609



Art. 191



Art. 2249



Art. 2173



Art. 109





1,2 cm			Art. 934
1,4 cm			Art. 2025
1,8 cm			Art. 180
2,4 cm			Art. 167
4 cm			Art. 110
3,2 cm			Art. 2024
3,4 cm			Art. 638
2 cm			Art. 123/C
1,8 cm			Art. 116
1,7 cm			Art. 128
1,7 cm			Art. 2022
1,4 cm			Art. 629

1,2 cm			Art. 181
1,3 cm			Art. 130
1,4 cm			Art. 126
0,9 cm			Art. 2122
1,1 cm			Art. 157
1,8 cm			Art. 635
1 cm			Art. 132
0,9 cm			Art. 145
1,1 cm			Art. 158
1,2 cm			Art. 2174
1,3 cm			Art. 2023
1 cm			Art. 2095
2,5 cm			Art. 2160
1,3 cm			Art. 136

Questi articoli sono realizzati con materiali specifici ed una tecnica particolare per ottenere un effetto a scomparsa.
These articles are manufactured in specific materials and by a special technique to obtain an embossed effect on the finished the ceiling surface.

1 cm
L 174 cm



Art. 2222



Esempio di realizzazione Art. 2222
Example of installation

1 cm
L 150 cm



Art. 2219

0,8 cm
L 150 cm



Art. 2218

Pannelli a scomparsa / Embossed-effect Panels



Art. 1655
146,5 x 20,5 cm



Art. 1656
134 x 20,5 cm

0,8 cm



34,5 cm

Art. 1646



Hotel Armonia - Pontedera (PI)

Gelateria Acropolis - Colle di Val D'Elsa (SI)
Acropolis ice-cream parlour - Colle di Val D'Elsa (SI)



Linea
Gesso

Gypsum Line

*Luci
Diffuse*

Lighting covers



Show room Color' Shop - Casapulla (CE)

Abitazione Maurizio Fiori - Certaldo (FI)
Maurizio Fiori's house - Certaldo (FI)





Art. 2135



Art. 2131



Art. 2092



Art. 2014

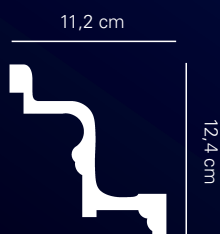

Art. 170



Art. 2040

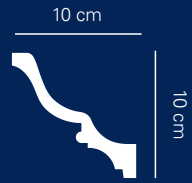

Art. 2027

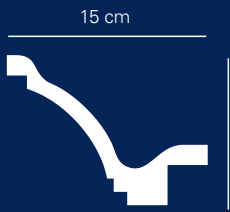

Art. 2096

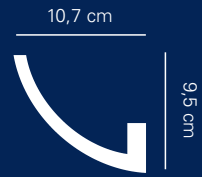

Art. 2080



Art. 111



Art. 2039



Art. 2015



Art. 626



Art. 2082



Art. 2091

Linea
Gesso

Gypsum Line

Angoli

Spigoli

Mezzerie

Centine

Inside Corners
Outside Corners
Corners
Curves
Dividers



Show room Color' Shop - Casapulla (CE)

Abitazione Privata - Colle di Val D'Elsa (SI)
Private home



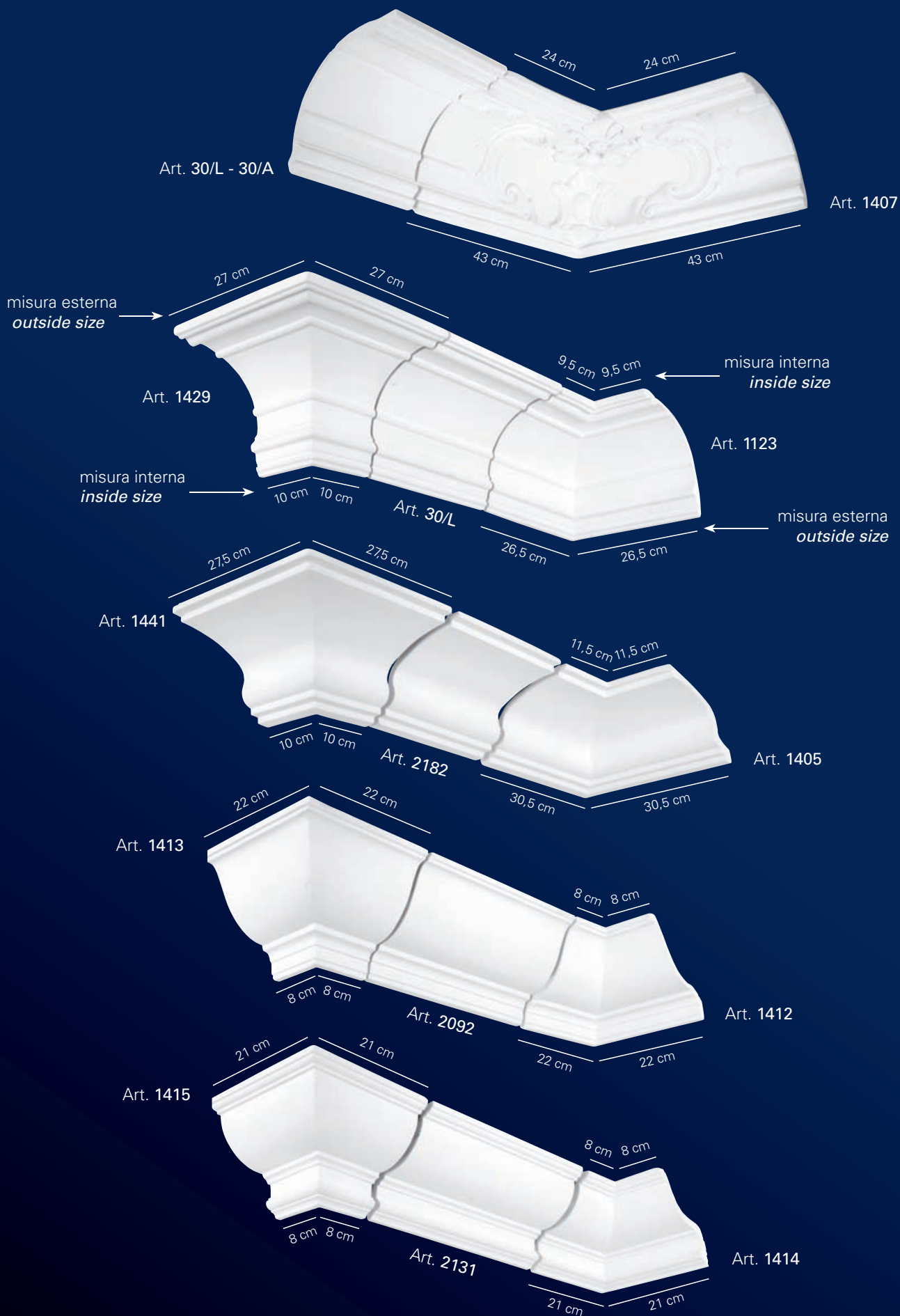

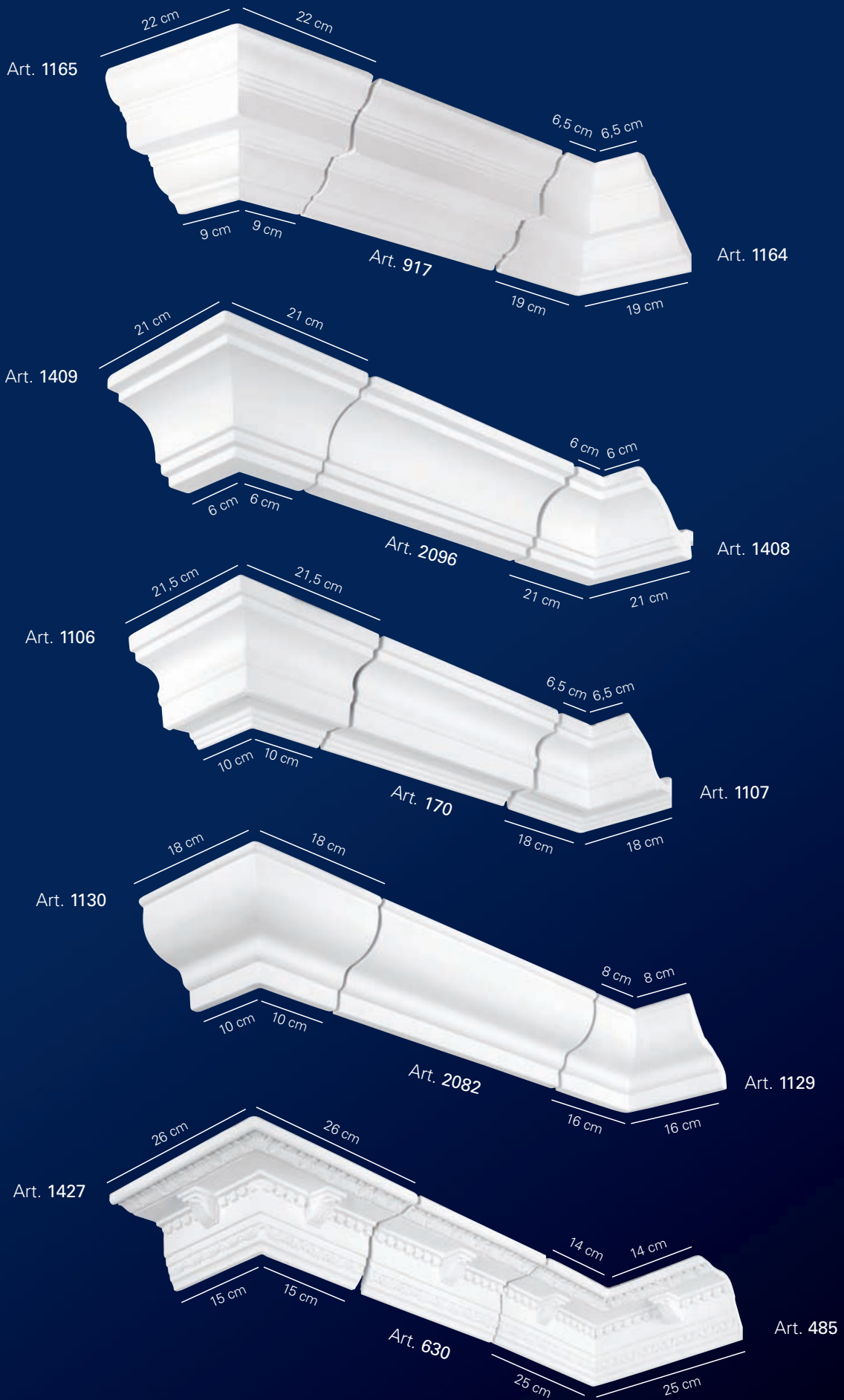

Art. 1125

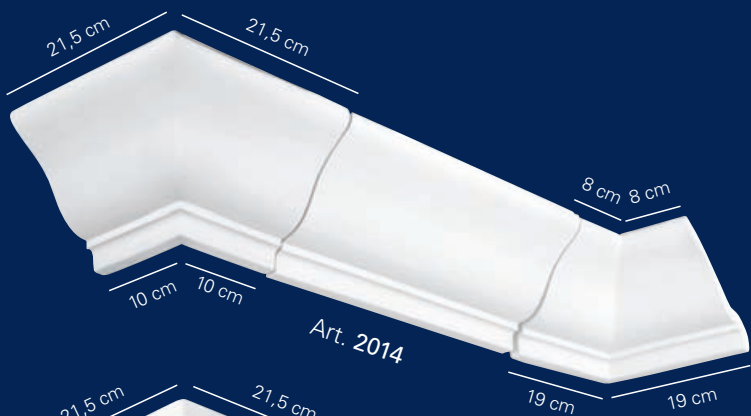

Art. 1104

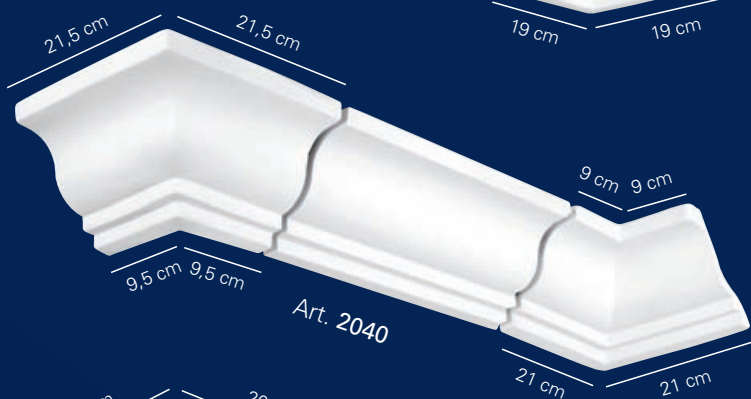

Art. 1110

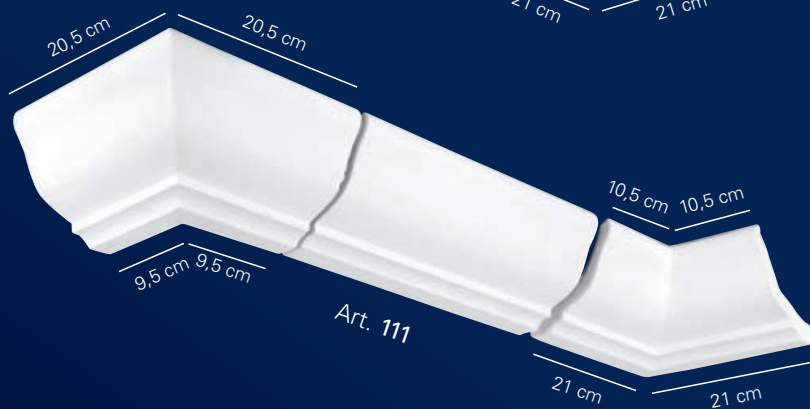

Art. 1114

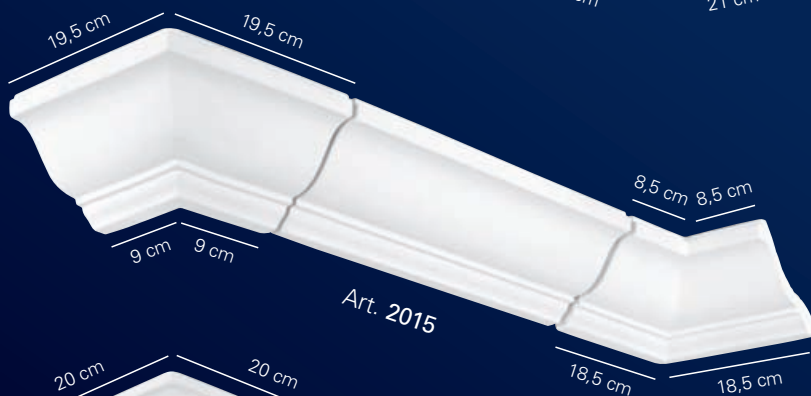

Art. 1108

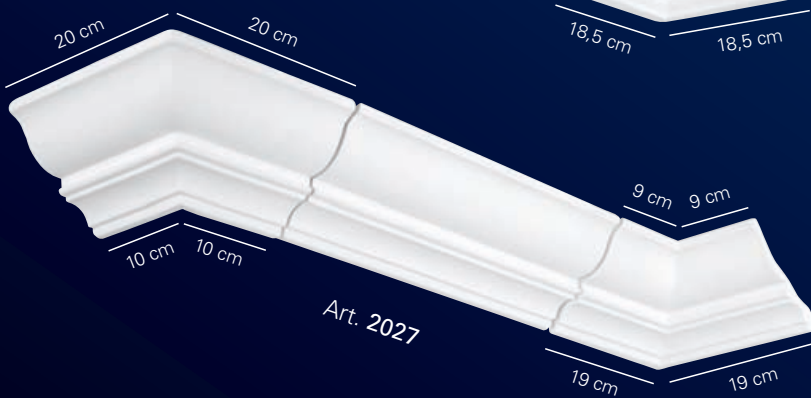

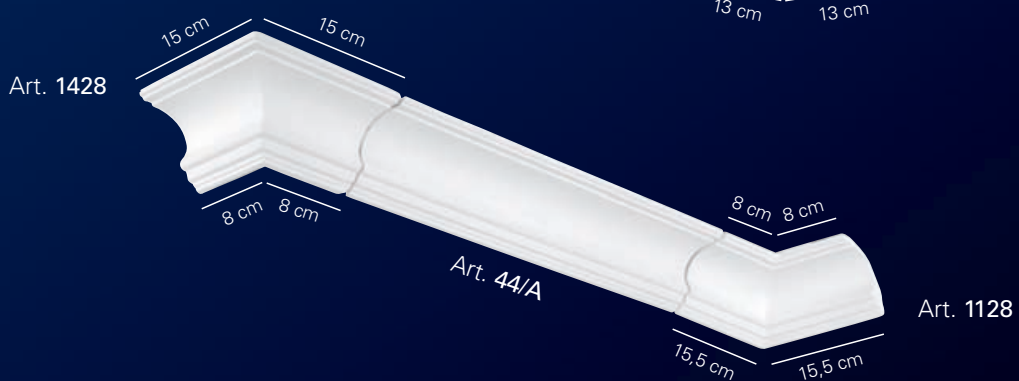
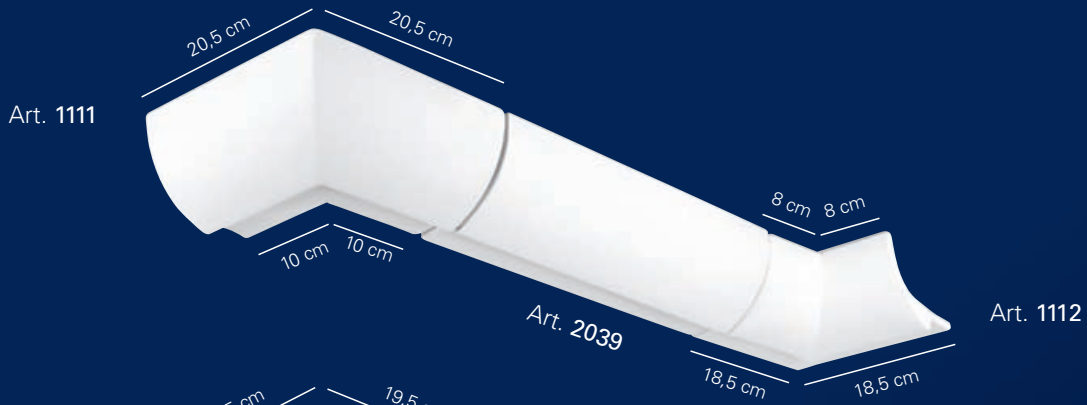
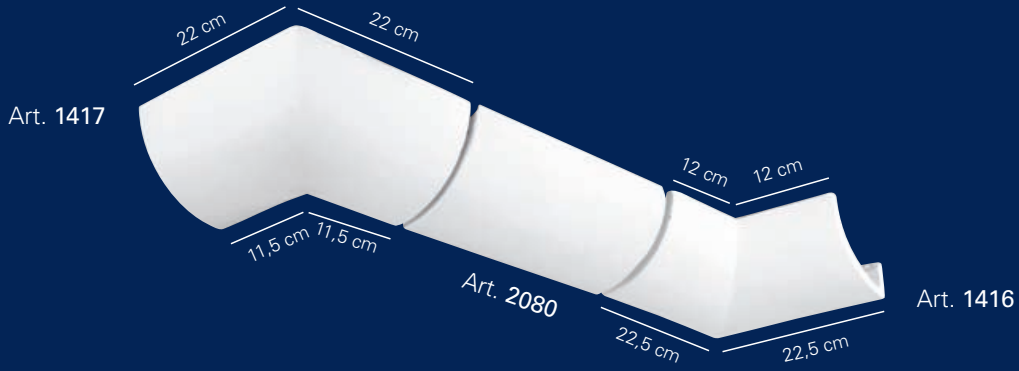

ABBINAMENTI CON LE CORNICI / COMPOSITIONS WITH FRAMES

CORNICE FRAME	ANGOLO CORNER	CENTINA CURVE	MEZZERIA DIVIDER	PAG	CORNICE FRAME	ANGOLO CORNER	CENTINA CURVE	MEZZERIA DIVIDER	PAG
49/A	64	-	-	71	2023	-	1031	-	79
52/A	63	-	-	72	2025	-	1040	-	79
102	432	401	-	74	2050	-	1126	-	71
103	1454	-	-	72	2095	-	1590	-	79
104	424	34-94	-	76	2104	-	1203	-	71
109	46	-	-	184	2123	1202	-	-	78
116	93-20	78 - 1632	83	73	2128	-	-	1214	185
119	43	461	-	75	2128	-	1673	-	71
121	85	27	-	78	2171	1438	-	-	79
122	405-74	53	-	74	2174	1382	-	-	78
123	62	84	-	74	2183	1439	-	-	79
126	69	68	-	73	2274	1633	-	-	79
128	1419 - 1599	21	-	77	2291	1663	-	-	79
130	58 - 1639 Dx-Sx	59	-	77	2291	1663	-	1596	186
132	49	52	-	74					
139	90	1030-1215	-	75					
140	404-450	61	-	76					
144	76	77	-	75					
145	70	71	-	77					
153	98	420	-	78					
156	1008	99	-	71					
157	91	97	-	77					
158	406-416	408 - 408/P	407	76					
159	458	459	-	74					
160	449	410	-	76					
164	454-419	-	-	74					
177	429	430	-	75					
179	452	45	-	75					
180	409	-	-	71					
181	66	72	-	74					
195	445-95	434	-	73					
196	433	1431	-	77					
601	444-443	-	-	77					
616	464	-	-	76					
622	468	467	-	73					
629	469	470	-	78					
647/B	80	-	-	72					
648/B	-	1471	-	79					
651/B	-	1122	-	78					
2007	1047	-	-	76					
2008	1067	-	-	79					

ANGOLO LIBERO FREE CORNER	PAG	LUCI DIFFUSE / LIGHTING COVES			
		CORNICE FRAME	ANGOLO INSIDE CORNER	SPIGOLO OUTSIDE CORNER	PAG
2	165	111	1013	1110	68
3	165	170	1107	1106	67
4	165	626	483	1113	69
7	165	2014	1124	1125	68
8	165	2015	1115	1114	68
35	164	2027	1109	1108	68
36	165	2039	1112	1111	69
81	165	2040	1105	1104	68
82	164	2080	1416	1417	69
436	165	2082	1129	1130	67
1034	164	2091	1336	1337	69
1035	164	2092	1412	1413	66
1161	165	2096	1408	1409	67
1261	165	2131	1414	1415	66
1451	164				
1453	164				
1472	165				

SGUSCI / COVING ELEMENTS			
CORNICE FRAME	ANGOLO INSIDE CORNER	SPIGOLO OUTSIDE CORNER	PAG
30/A	1407	-	66
30/L	1123	1429	66
44/A	1128	1428	69
630	485	1427	67
917	1164	1165	67
2182	1405	1441	66

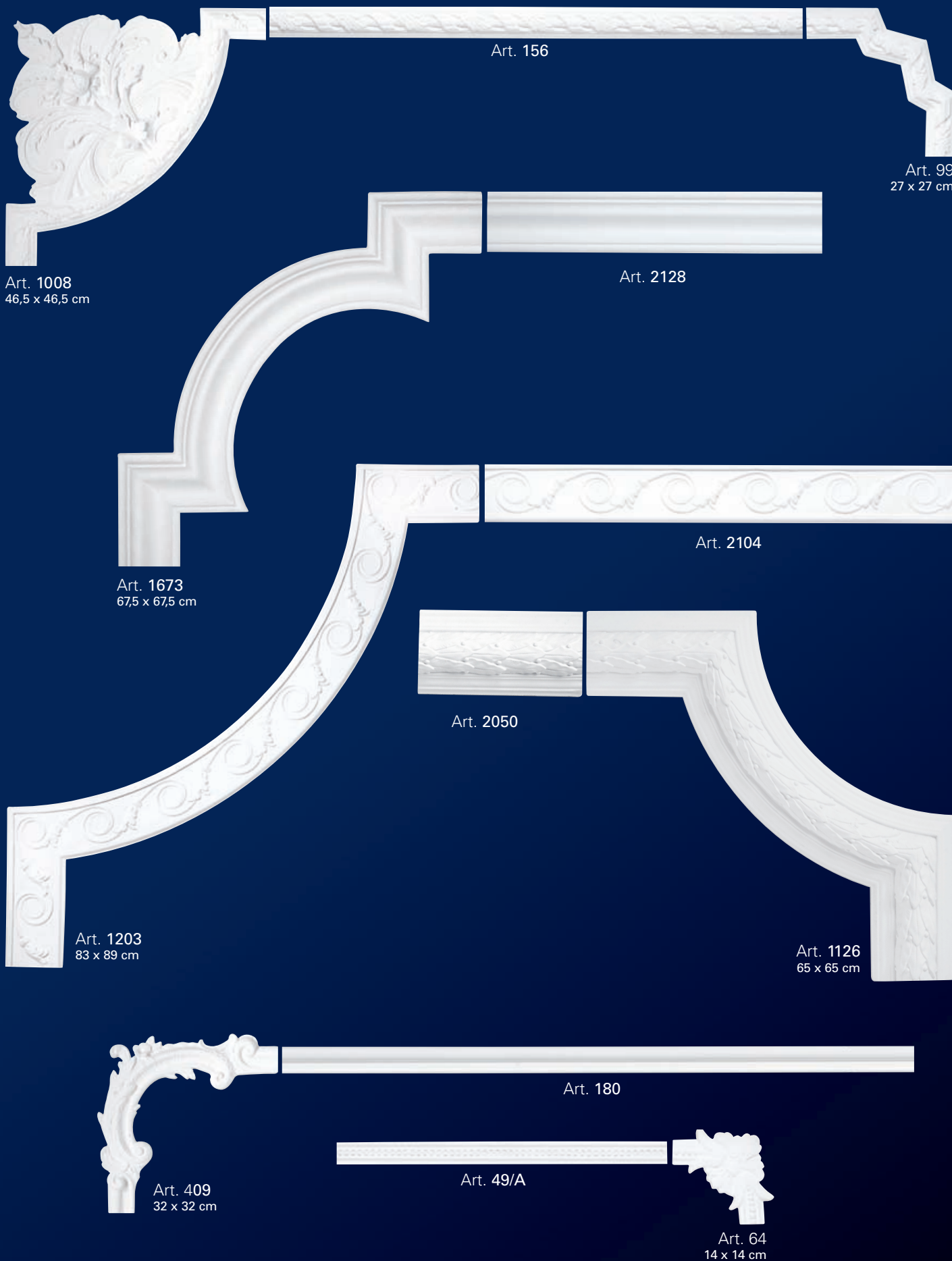

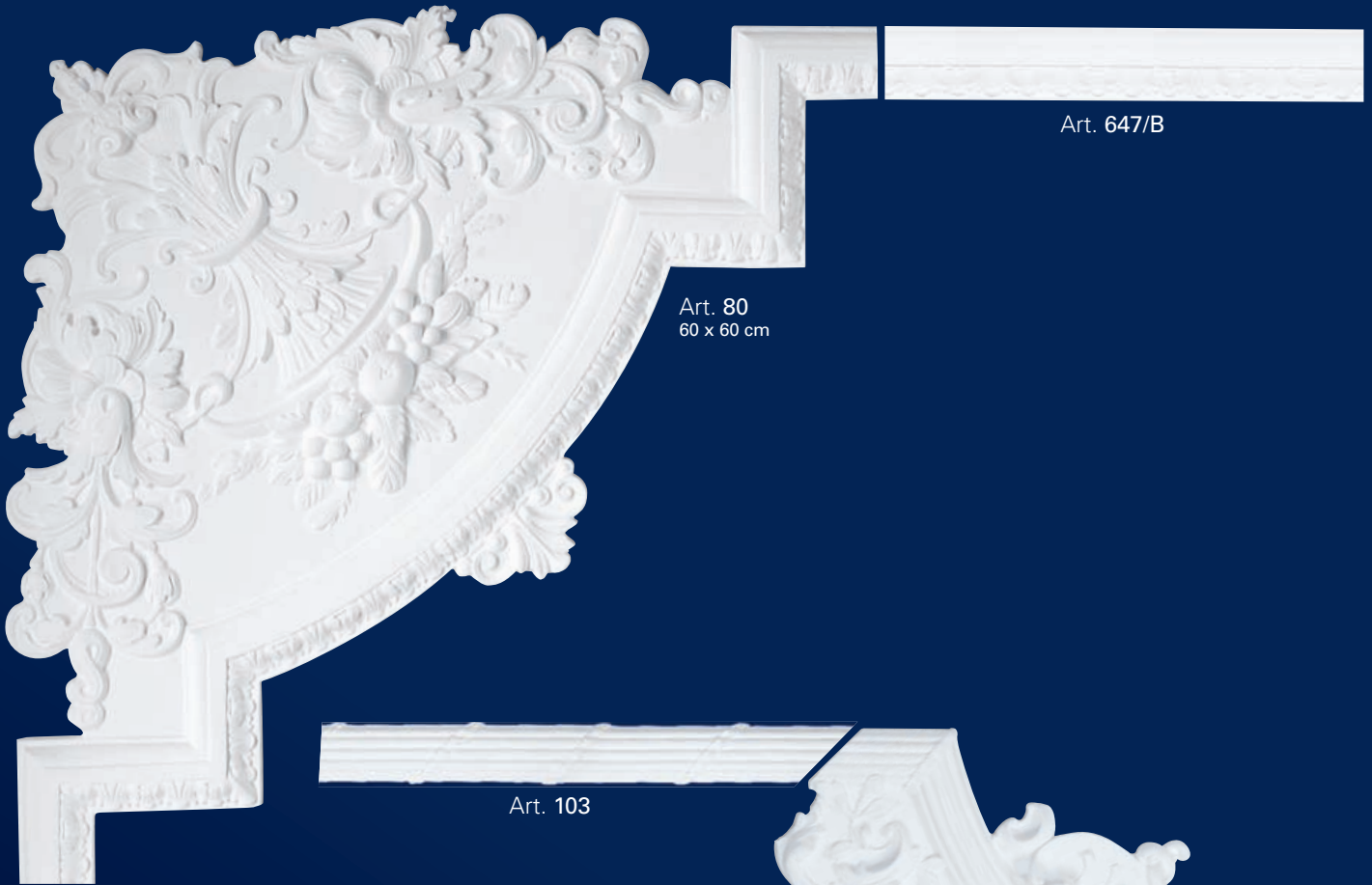

Art. 80
60 x 60 cm

Art. 647/B

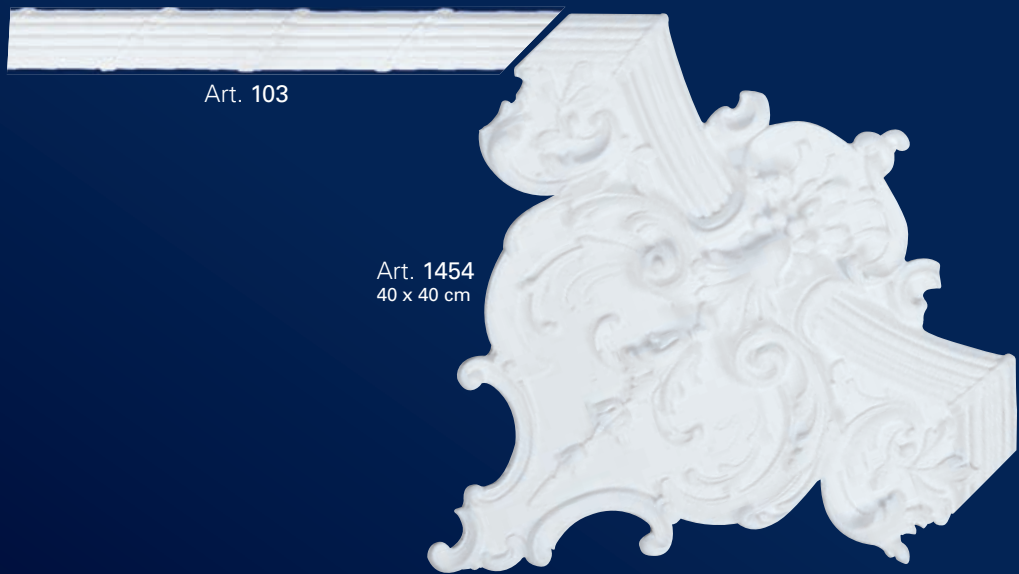

Art. 103

Art. 1454
40 x 40 cm

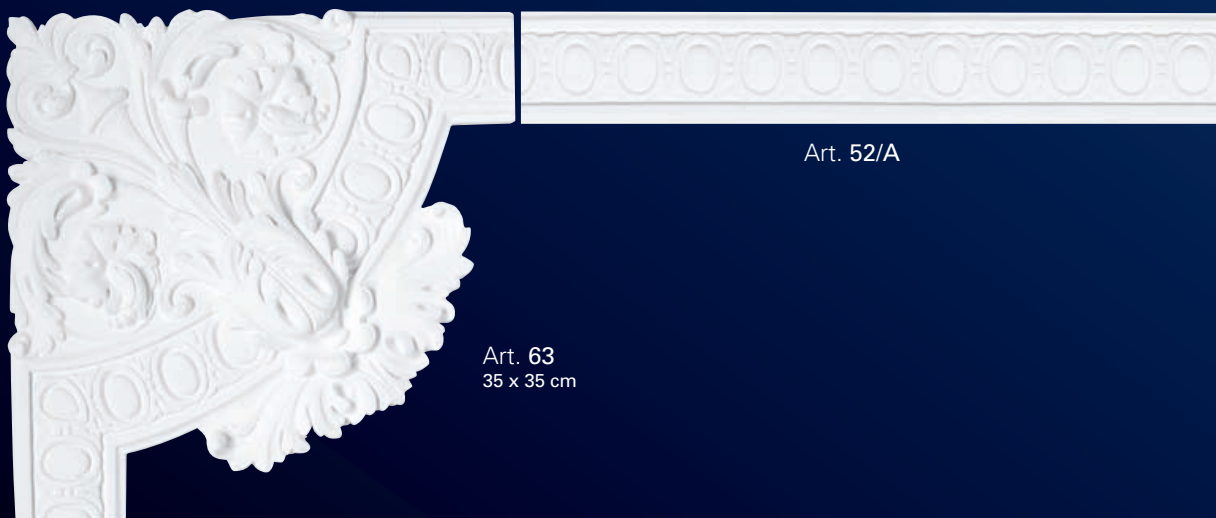

Art. 63
35 x 35 cm

Art. 52/A



Corners - Dividers - Curves

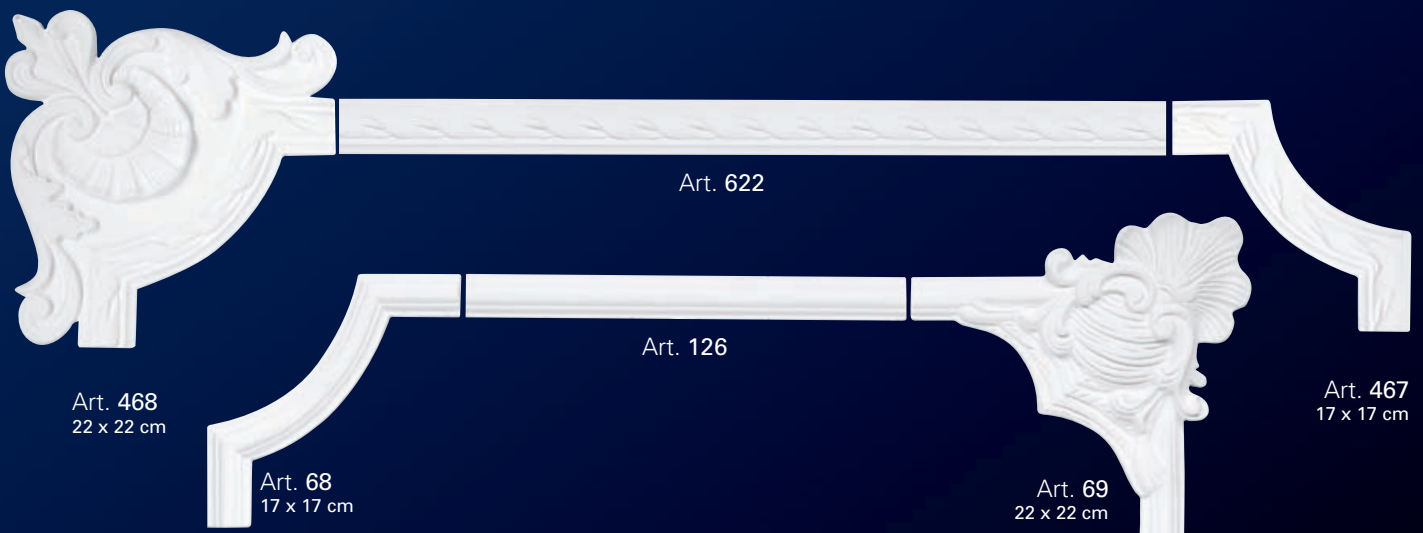
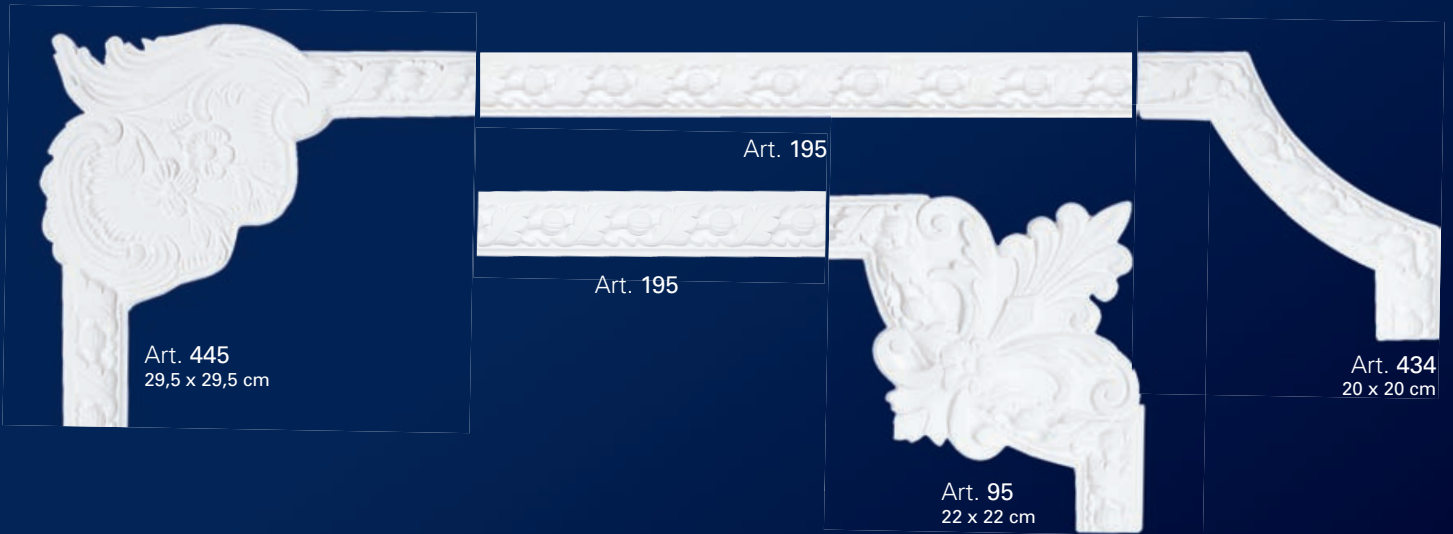
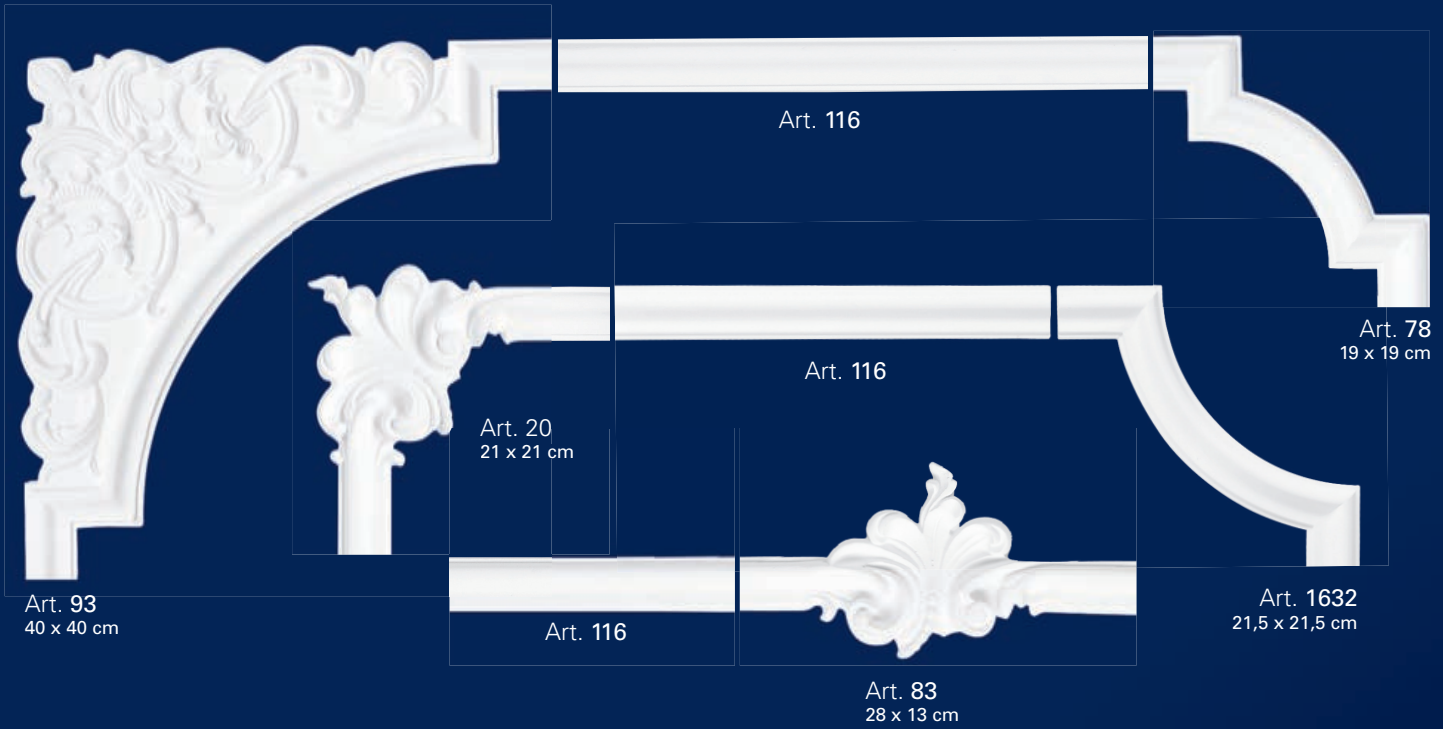

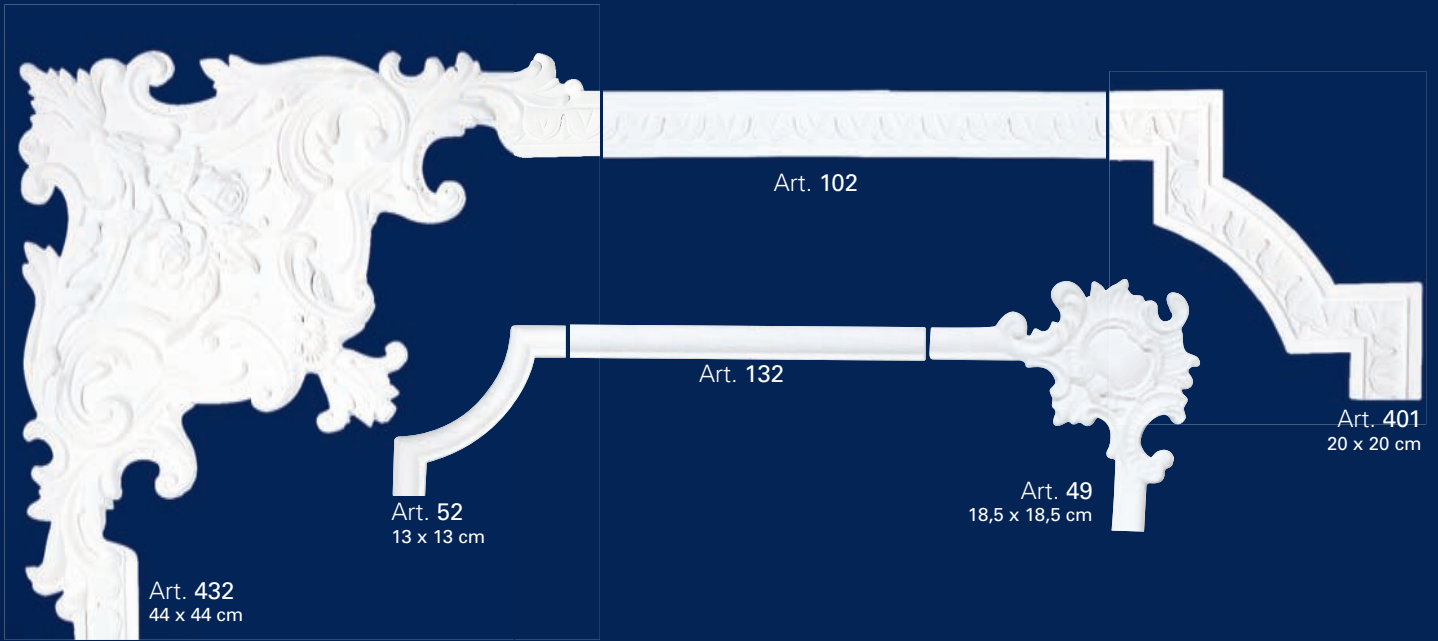

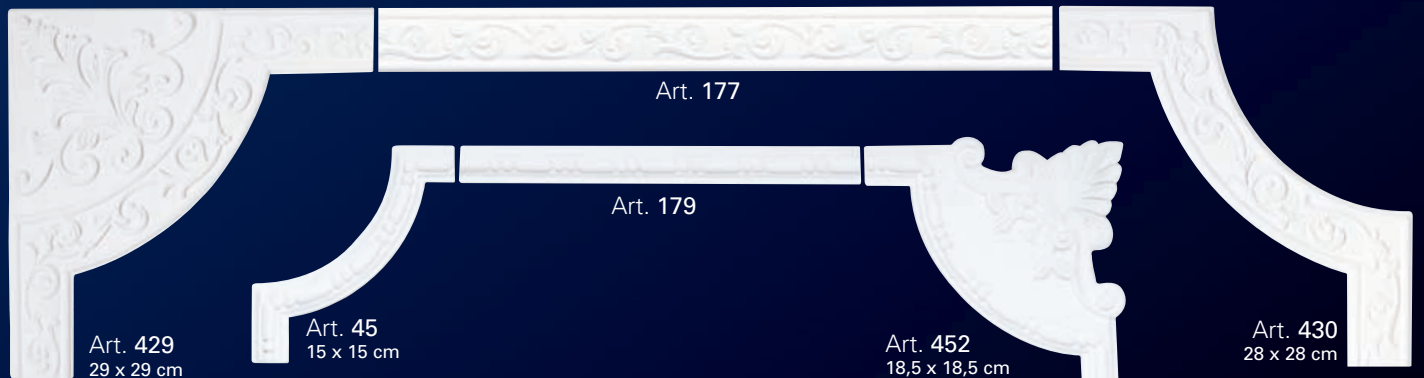
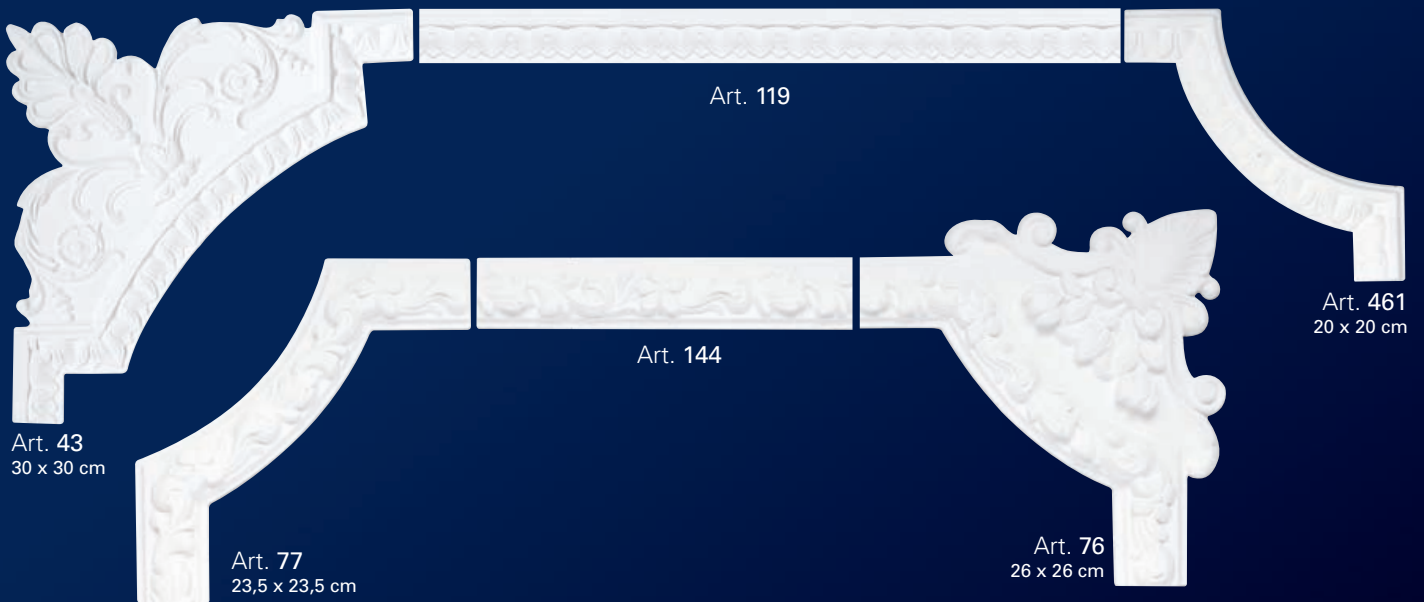
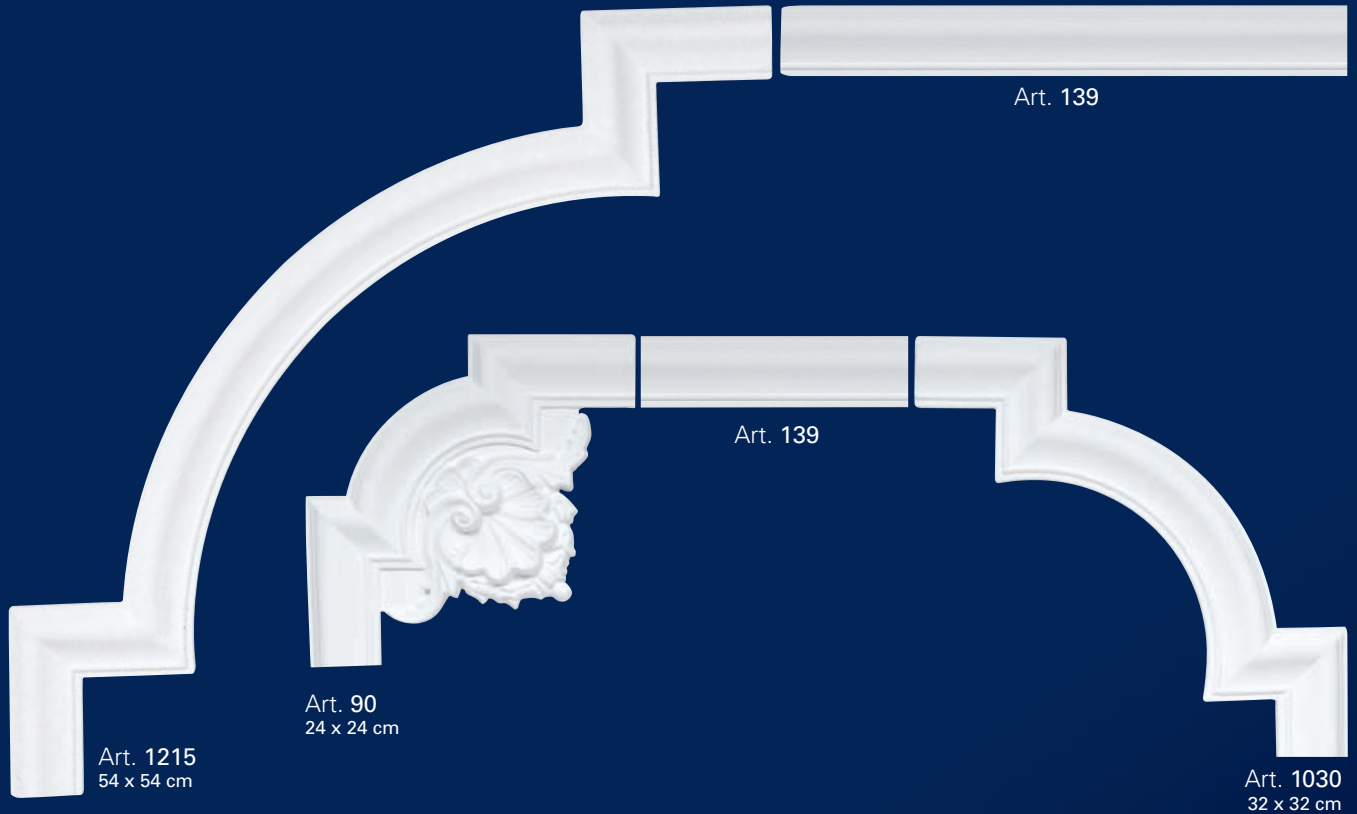

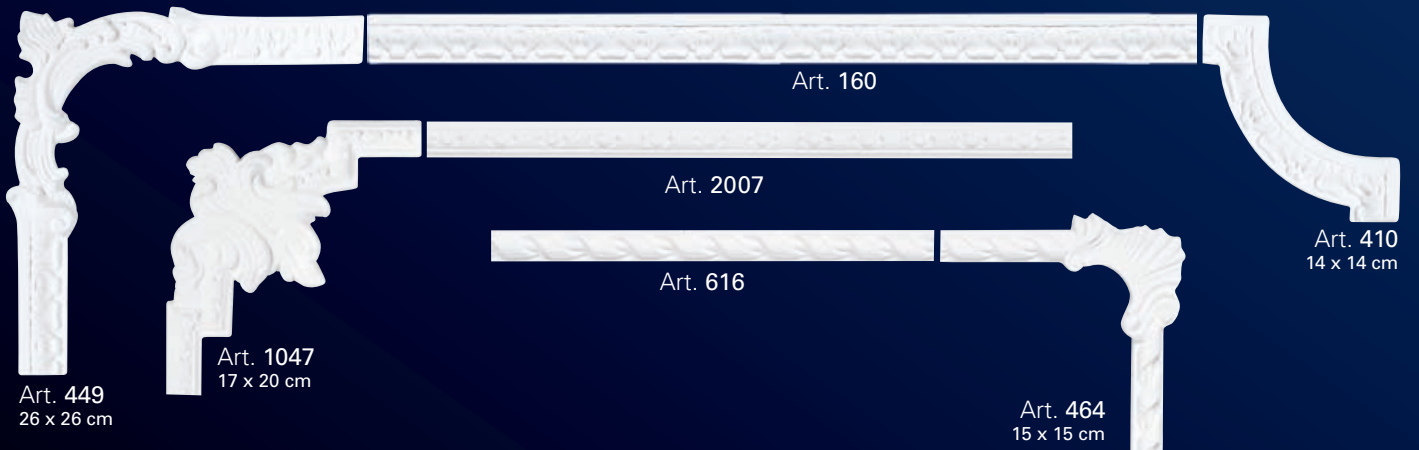
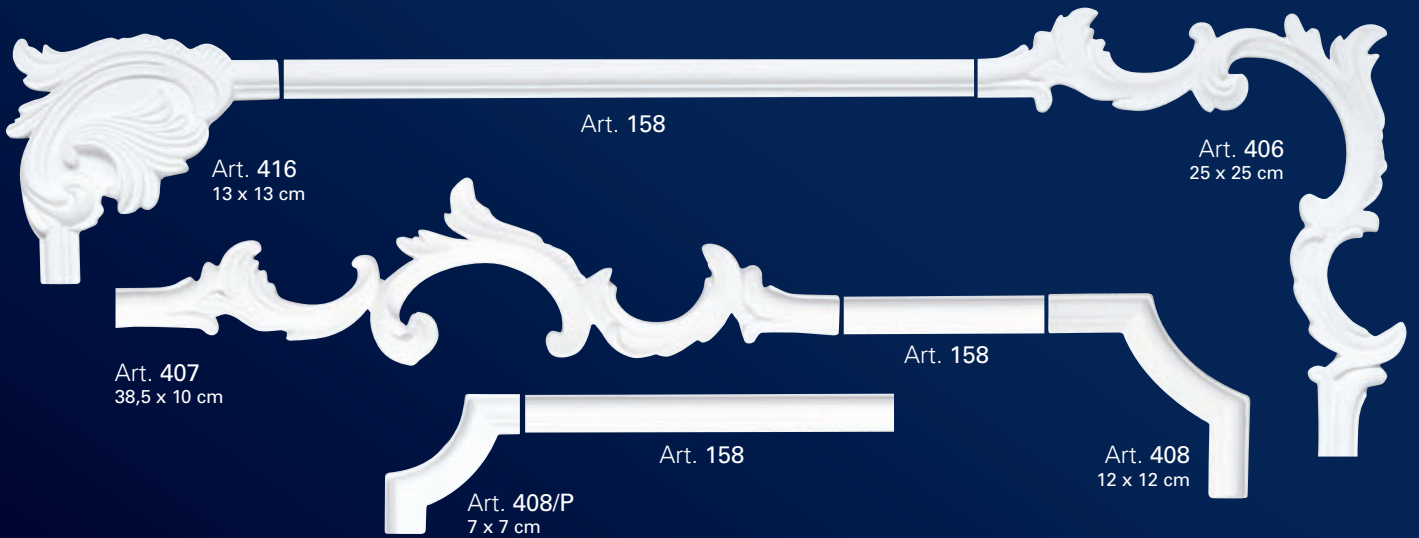
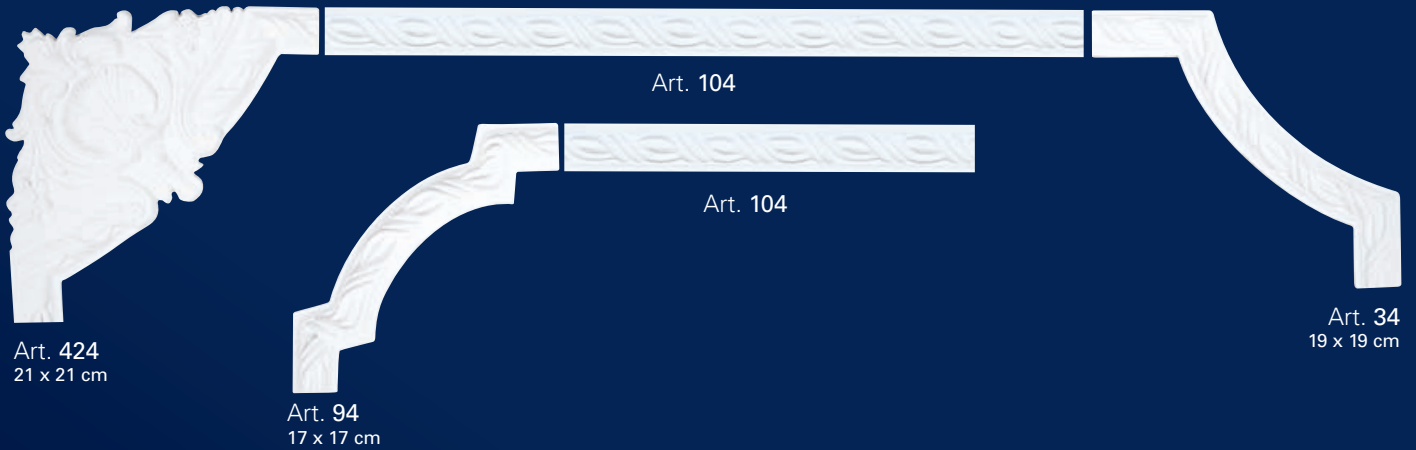



Corners - Dividers - Curves

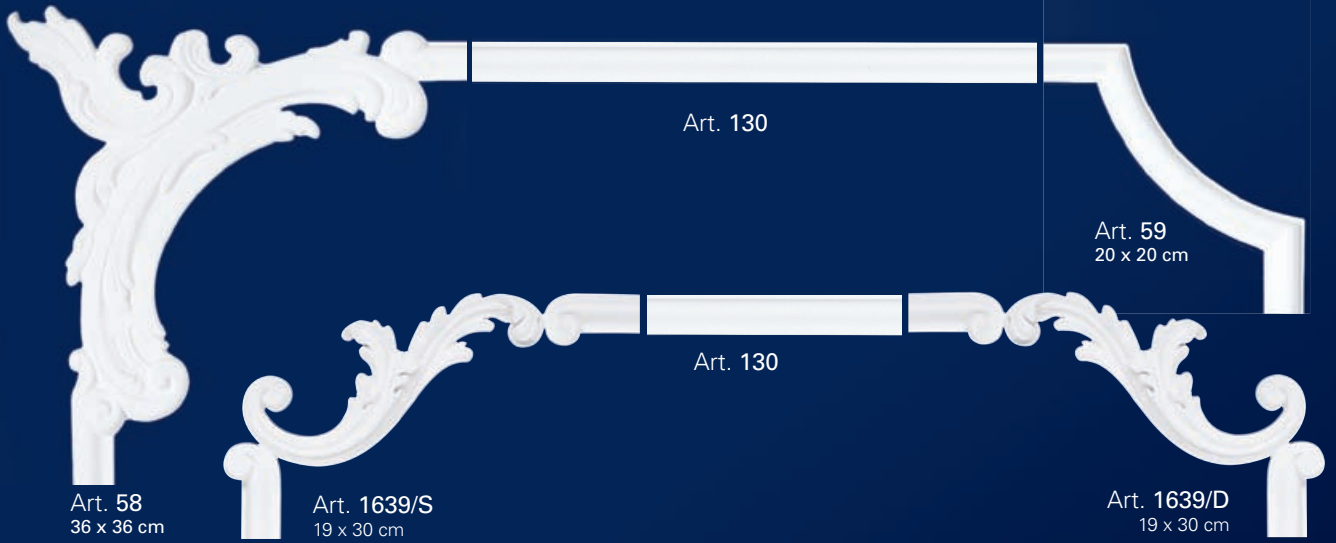
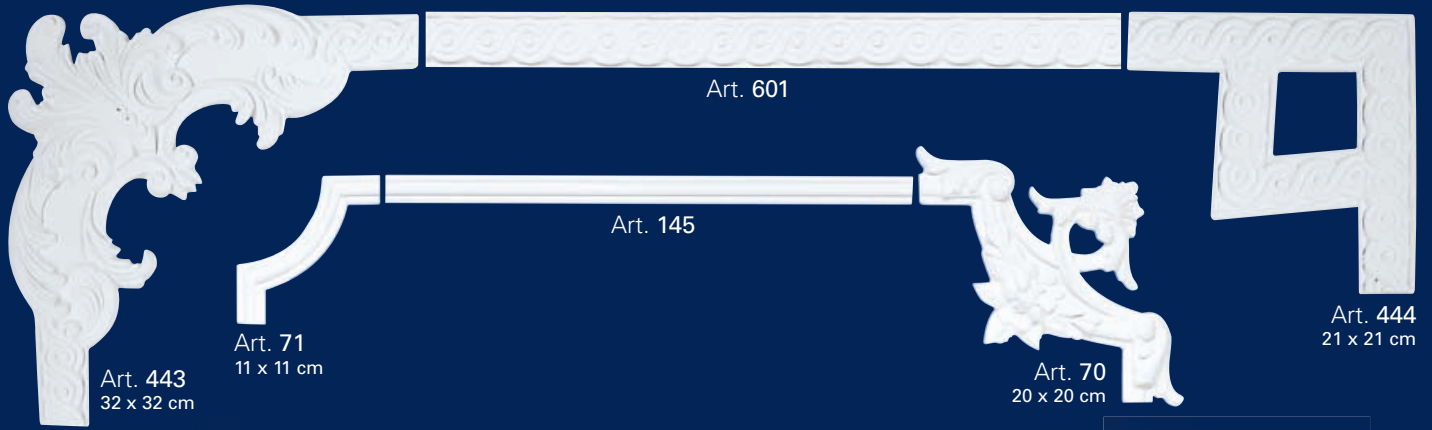

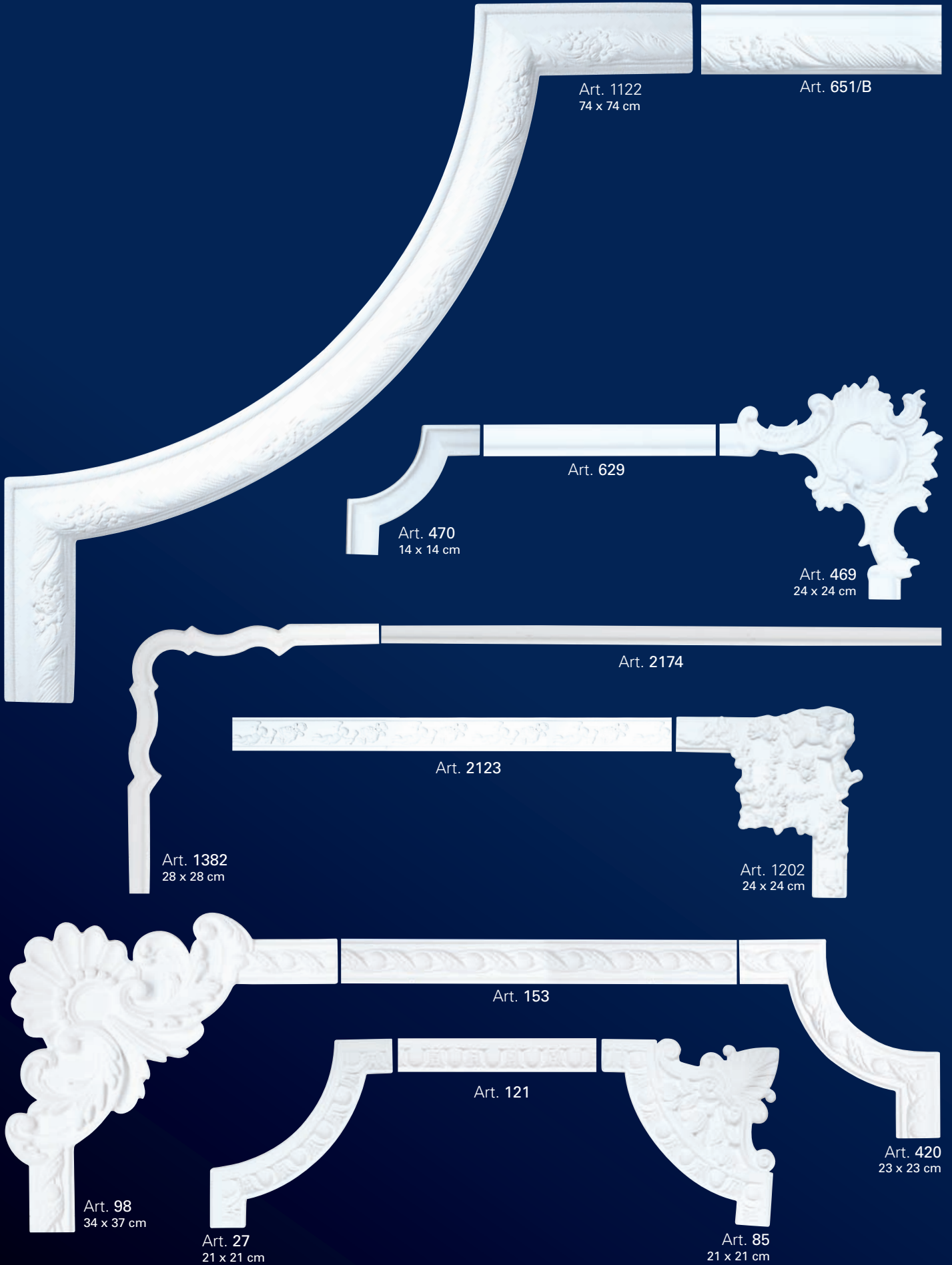



Corners - Dividers - Curves



Art. 1439
34 x 30 cm

Art. 2183

Art. 2025



Art. 1438
22,5 x 17,5 cm

Art. 2171

Art. 1040
30 x 30 cm

Art. 2008

Art. 1067
18 x 18 cm



Art. 1633
19 x 19 cm

Art. 2274

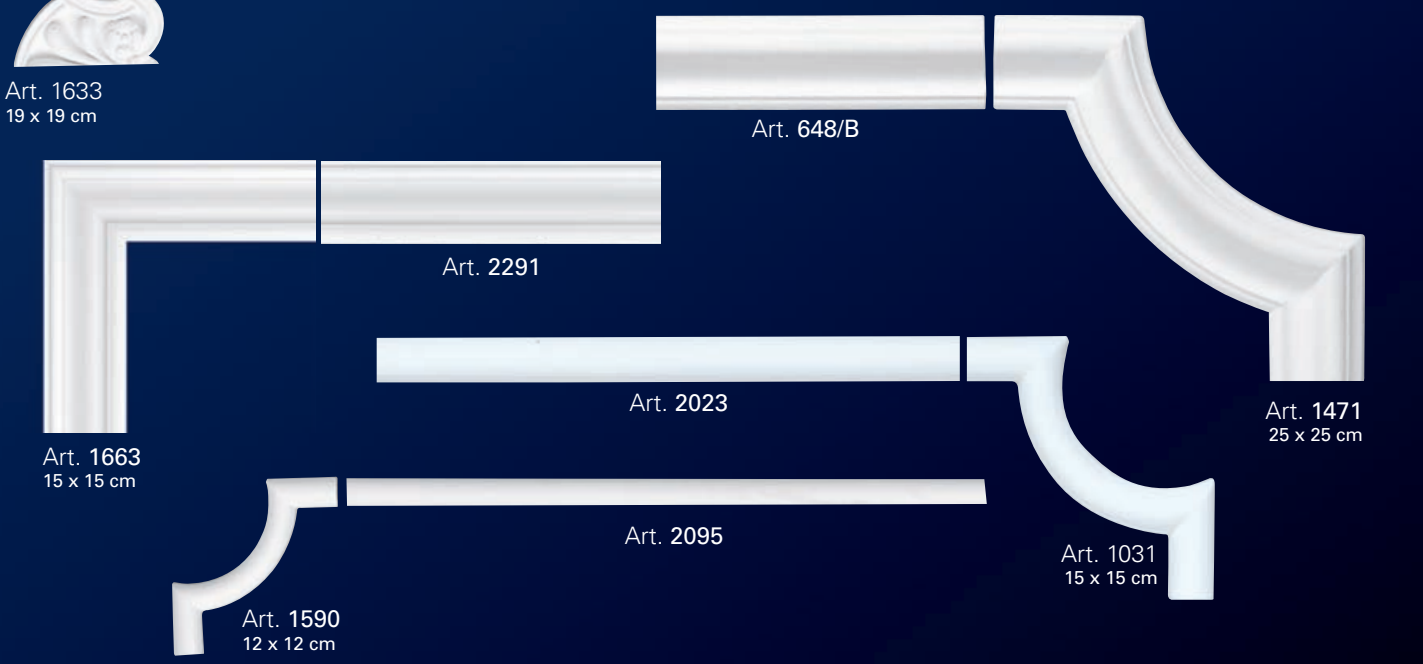

Art. 1633
19 x 19 cm

Art. 648/B

Art. 2291

Art. 1471
25 x 25 cm

Art. 1663
15 x 15 cm

Art. 2023

Art. 2095

Art. 1031
15 x 15 cm

Art. 1590
12 x 12 cm

Linea
Gesso

Gypsum Line

Rosoni

Ceiling Rosettes



Four Seasons Hotel - Firenze - *Four Seasons Hotel - Florence*



Art. 391
138 x 97 cm



Art. 393
ø 88,5 cm



Art. 392
ø 88 cm



Art. 306
89 x 65 cm



Art. 991
ø 76 cm



Art. 296
ø 75 cm



Art. 257
ø 69 cm



Art. 299
82 x 59 cm



Art. 853
73 x 51,5 cm



Art. 304
66 x 92 cm



Art. 256
71,5 x 106 cm



Art. 291
ø 60 cm



Art. 383
ø 65,5 cm



Art. 347
ø 63 cm



Art. 249
67 x 82 cm



Art. 334
ø 66 cm



Art. 399
ø 85 cm



Art. 255
ø 66 cm



Art. 865
ø 60 cm
p 9 cm



Art. 343
ø 65 cm



Art. 260
65 x 50 cm



Art. 316
61,5 x 45,5 cm



Art. 201
61 x 41,5 cm



Art. 380
57 x 42 cm



Art. 302
57 x 38 cm



Art. 860
ø 55 cm



Art. 315
ø 57 cm



Art. 293
ø 57 cm



Art. 322
ø 55 cm



Art. 358
ø 56 cm



Art. 969
61 x 31,5 cm



Art. 310
ø 53,5 cm



Art. 286
ø 54 cm



Art. 360
52,5 x 38,5 cm



Art. 245
ø 52 cm



Art. 252
ø 51 cm



Art. 972
ø 52 cm



Art. 279
ø 52 cm



Art. 295
ø 52 cm



Art. 330
ø 51 cm



Art. 261
52 x 31,5 cm



Art. 975
ø 51 cm



Art. 974
ø 50,5 cm



Art. 852
51 x 43 cm



Art. 369
ø 50 cm



Art. 973
ø 50 cm



Art. 225
ø 50 cm



Art. 382
ø 50 cm



Art. 381
49 x 36 cm



Art. 292
ø 50 cm



Art. 861
ø 50 cm



Art. 331
ø 50 cm



Art. 259
ø 47 cm



Art. 857
46,5 x 24 cm



Art. 215
50 x 27 cm



Art. 226
ø 49 cm



Art. 224
ø 48 cm



Art. 345
ø 49 cm



Art. 328
ø 48 cm



Art. 851
ø 46 cm



Art. 243
ø 46 cm



Art. 342
ø 46 cm



Art. 300
ø 46,5 cm



Art. 863
ø 46 cm



Art. 324
ø 45 cm



Art. 862
ø 45 cm



Art. 298
ø 45 cm



Art. 290
ø 44 cm



Art. 389
ø 43,5 cm



Art. 371
ø 44 cm



Art. 321
ø 42,5 cm



Art. 289
ø 43 cm



Art. 210
65 x 40 cm



Art. 272
ø 42 cm



Art. 963
ø 43 cm



Art. 327
ø 43 cm



Art. 856
42 x 59 cm



Art. 309
ø 42 cm



Art. 287
ø 42 cm



Art. 312
41 x 56 cm



Art. 220
ø 41 cm



Art. 227
ø 41 cm



Art. 971
43 x 23 cm



Art. 361
ø 41,5 cm



Art. 242
ø 40 cm



Art. 203
40 x 27 cm



Art. 370
ø 40 cm



Art. 297
ø 40 cm



Art. 213
40 x 29,5 cm



Art. 236
ø 41 cm



Art. 859
ø 39 cm



Art. 311
ø 39 cm



Art. 251
ø 39 cm



Art. 228
ø 38,5 cm



Art. 223
ø 35 cm



Art. 270
38 x 29 cm



Art. 978
ø 38 cm



Art. 858
ø 34 cm



Art. 313
ø 35 cm

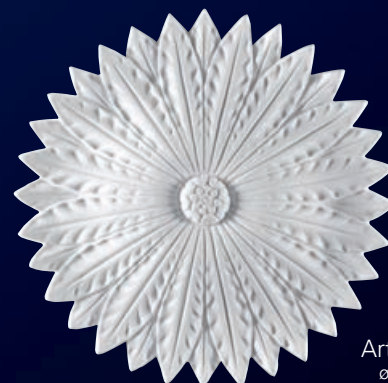

Art. 962
ø 35 cm



Art. 854
57 x 38 cm



Art. 247
ø 32 cm



Art. 217
32 x 57 cm



Art. 237
ø 32 cm



Art. 221
ø 37 cm



Art. 276
ø 32 cm



Art. 275
ø 33 cm



Art. 864
ø 37 cm



Art. 323
ø 31,5 cm



Art. 278
ø 33 cm



Art. 288
31 x 44 cm



Art. 212
ø 29 cm



Art. 208
25 x 20 cm



Art. 314
ø 30 cm



Art. 997
ø 25 cm



Art. 999
ø 20 cm



Art. 229
ø 30 cm



Art. 993
ø 28 cm



Art. 214
ø 26 cm



Art. 216
ø 26 cm



Art. 244
ø 30 cm



Art. 996
ø 26 cm



Art. 241
ø 29 cm



Art. 964
ø 38 cm



Art. 979
ø 20 cm



Art. 985
45,5 x 32,5 cm



Art. 980
ø 24,5 cm



Art. 355
ø 28 cm



Art. 981
ø 29 cm



Art. 984
36,5 x 27,5 cm



Art. 965
ø 30 cm



Art. 982
ø 34 cm



Art. 968
38,5 x 29 cm



Art. 966
ø 23 cm



Art. 983
ø 39,5 cm



Art. 990
ø 61 cm



Art. 950
ø 48 cm



Art. 364
ø 40,5 cm



Art. 352
ø 48 cm



Art. 238
ø 29 cm



Art. 274
ø 37,5 cm



Art. 363
45,5 x 23 cm

Questi rosoni sono realizzati con materiali specifici ed una tecnica particolare per ottenere un effetto a scomparsa sul soffitto.
These rosettes are manufactured in specific materials and by a special technique to obtain an embossed effect on the finished the ceiling surface.



Art. 986
ø 69 cm



Esempio di realizzazione Art. 986
Example of installation



Art. 867
ø 124 cm



Art. 870
h 128 cm
l 122 cm
diag. 147 cm



Art. 871
ø 61 cm



Art. 987
ø 67 cm



Art. 868
152 x 104 cm



Art. 872
ø 80 cm



Art. 874
125 x 53 cm



Art. 869
ø 61 cm

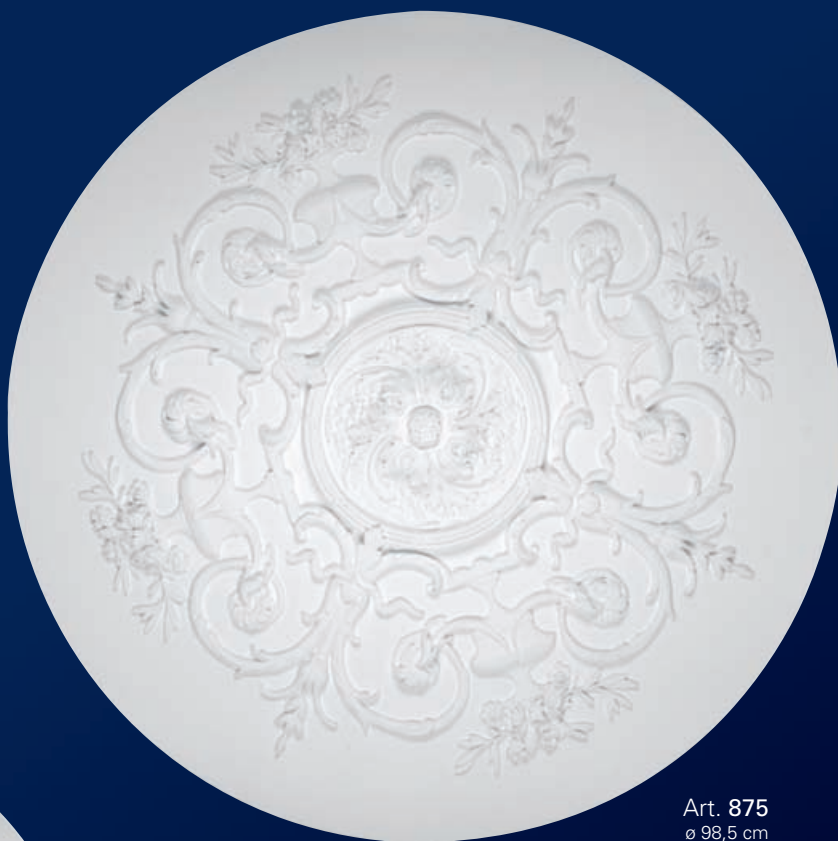

Art. 875
ø 98,5 cm



Art. 989
ø 73,5 cm



Art. 866
ø 92,5 cm



Art. 873
ø 69 cm



Art. 988
ø 95 cm



Hotel Alba - Pescara

Four Seasons Hotel - Firenze
Four Seasons Hotel - Florence



Linea
Gesso

Gypsum Line



Bassorilievi

Bas-reliefs



1

1 - 2 Villa Privata - Yerevan (Armenia)
Private villa - Yerevan (Armenia)



2

Four Seasons Hotel - Firenze
Four Seasons Hotel - Florence





Art. 19
34 x 118 cm



Art. 1634
ø 76 cm



Art. 1637
ø 76 cm



Art. 1636
ø 76 cm



Art. 1635
ø 76 cm



Art. 1135
52 x 118 cm



Art. 1144
40 x 101 cm



Art. 1230
74 x 119 cm
p 6 cm



Art. 18
57 x 66 cm



Art. 1233
22,5 x 49 cm



Art. 1232
46 x 72 cm



Art. 1016
85,5 x 85,5 cm



Art. 1325
ø 65 cm
p 10 cm



Art. 1231
51 x 112 cm



Art. 1143
50 x 60 cm



Art. 1142
48 x 38,5 cm



Art. 1141
48 x 38,5 cm



Art. 1338
57 x 109 cm
p 7 cm



Art. 1133
43 x 35 cm



Art. 1267
42 x 75,5 cm
p 4 cm

Linea
Gesso

Gypsum Line

Lesene

Pilasters



Villa Privata - Yerevan (Armenia) - Private villa - Yerevan (Armenia)

Ristorante da Iva - Bucchianico (CH)



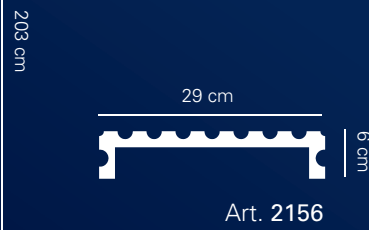
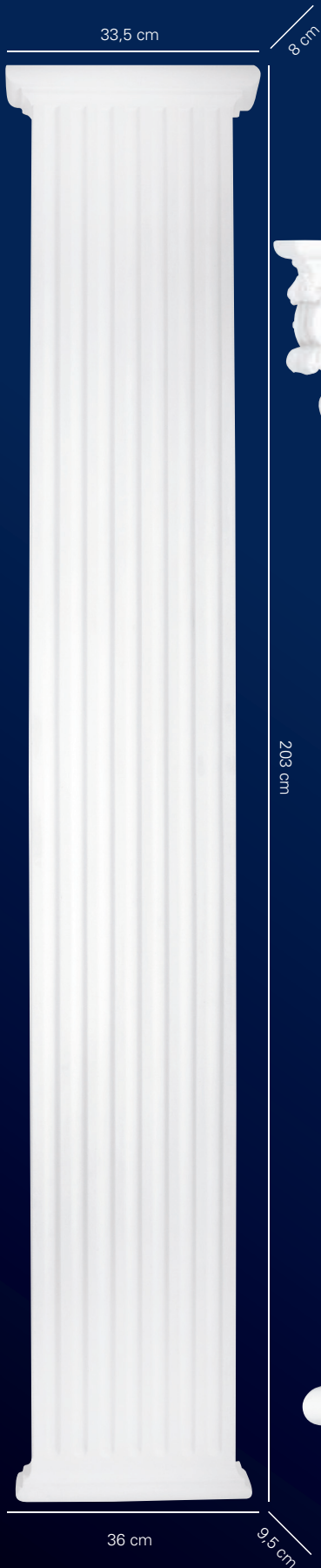



Art. 1654
h 26 cm - l 55 cm - p 17 cm
con sguscio /
with coving element Art. 2150



Art. 1247
h 20 cm - l 31 cm - p 8 cm
20 cm



3 cm

Art. 1582/S
h 18,5 cm - l 38,5 cm - p 12 cm
con cornice /
with frame Art. 2209



Art. 1461
h 10 cm
l 15 cm



Art. 1460
h 29,3 cm
l 15 cm



Art. 2194
l 15 cm
p 2,5 cm

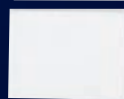

Art. 1459
h 12 cm - l 16 cm - p 3 cm



2,5 cm

Art. 1583
h 18,5 cm - l 41,5 cm - p 12 cm



Art. 2132
h 166 cm - l 18 cm

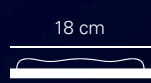

2,4 cm

Art. 1582/D
h 18,5 cm - l 38,5 cm - p 12 cm



Art. 1652
h 10 cm
l 17,2 cm



Art. 2220
l 17,2 cm - p 3 cm



3 cm

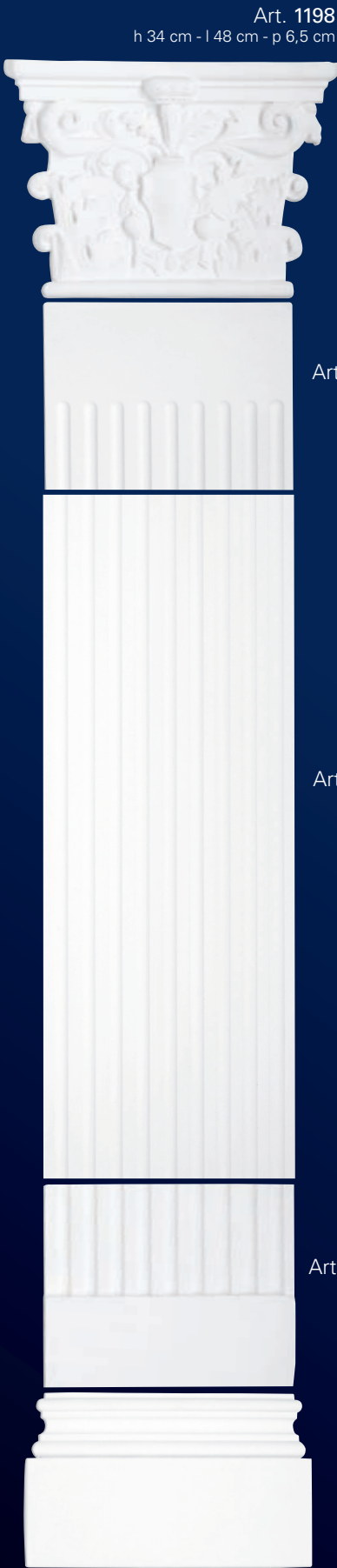

Art. 1198
h 34 cm - l 48 cm - p 6,5 cm

Art. 1101/T
h 28 cm
l 33 cm

Art. 2073
l 33 cm
p 2 cm

Art. 1101/B
h 28 cm
l 33 cm

Art. 1216
h 24,5 cm - l 40 cm - p 5 cm

33 cm

2 cm



Art. 1239
h 13 cm - l 57 cm - p 13 cm

Art. 1101/T
h 28 cm
l 33 cm

Art. 2073
l 33 cm
p 2 cm

Art. 1101/B
h 28 cm
l 33 cm

Art. 1216
h 24,5 cm - l 40 cm - p 5 cm

33 cm

2 cm



Art. 386
h 29,5 cm - l 54,5 cm - p 15 cm

Art. 1212
h 34,5 cm
l 30,5 cm

Art. 645/B
l 30,5 cm
p 3,7 cm

Art. 1212
h 34,5 cm
l 30,5 cm

Art. 386/C
h 22 cm - l 44 cm - p 11 cm
30,5 cm

3,7 cm

2 cm



Art. 1116
h 25 cm - l 41 cm - p 12 cm

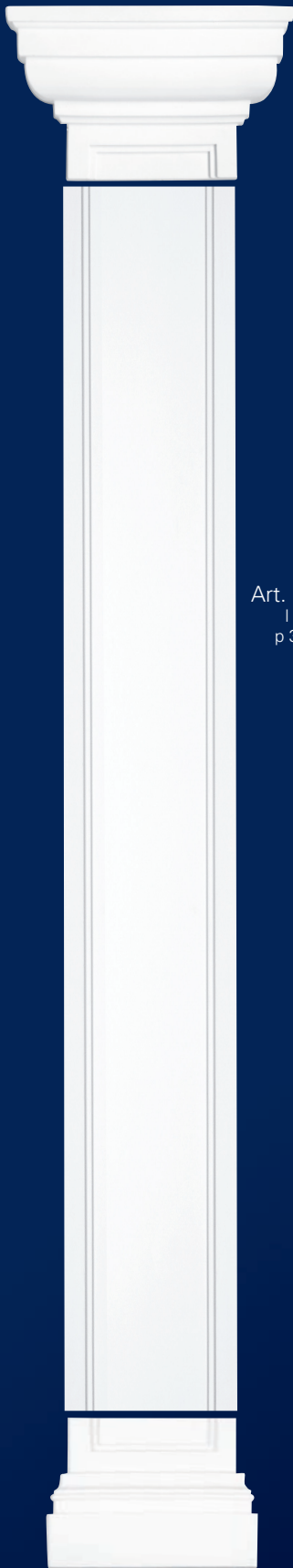

Art. 1117
h 22,5 cm - l 31 cm - p 7 cm



Art. 1344
h 31,5 cm - l 41 cm - p 6 cm

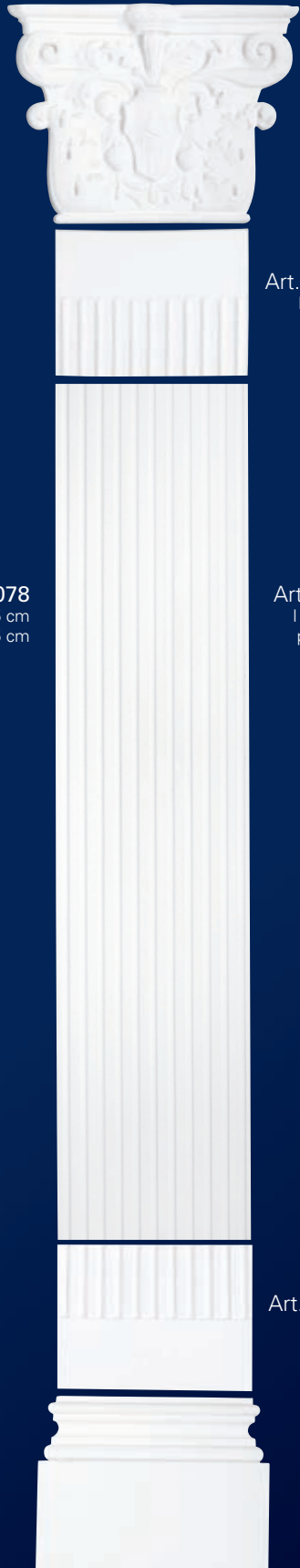

Art. 1345
h 25 cm - l 32,5 cm - p 4 cm

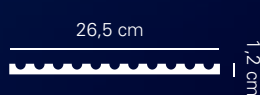

Art. 1245
h 27 cm - l 42 cm - p 13 cm

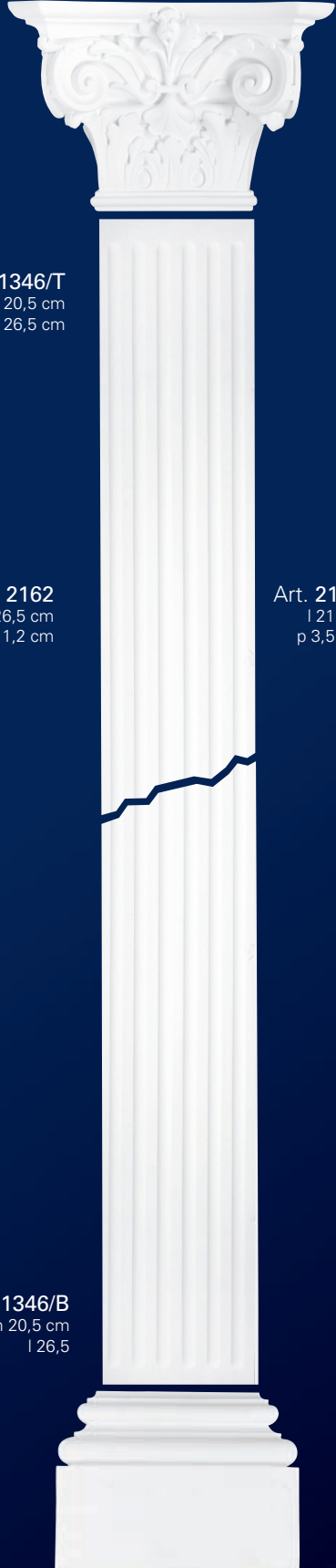

Art. 1247
h 20 cm - l 31 cm - p 8 cm



Art. 418
h 22 cm - l 28 cm - p 5 cm

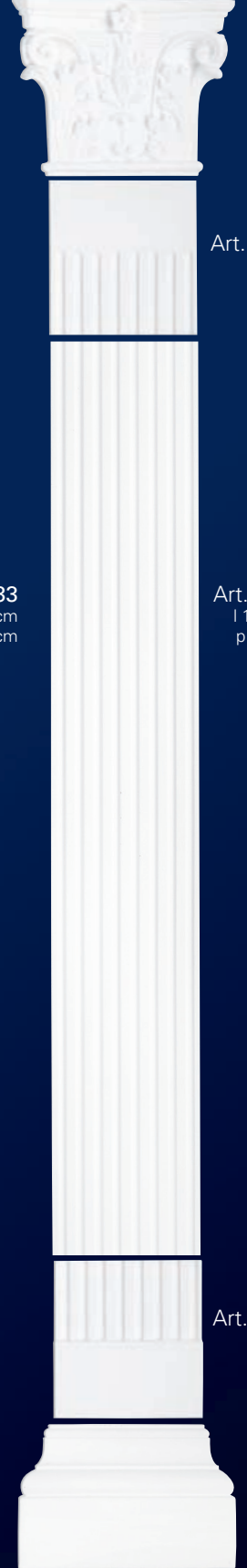

Art. 418/C
h 18 cm - l 27 cm - p 5 cm

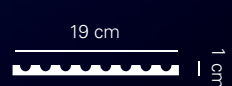

Art. 2078
l 25 cm
p 3,5 cm

Art. 1346/T
h 20,5 cm
l 26,5 cm

Art. 2162
l 26,5 cm
p 1,2 cm

Art. 1346/B
h 20,5 cm
l 26,5

Art. 2133
l 21 cm
p 3,5 cm

Art. 1100/T
h 21 cm
l 19 cm

Art. 611
l 19 cm
p 1 cm

Art. 1100/B
h 21 cm
l 19 cm

Art. 16
h 10 cm - l 25 cm - p 6,5 cm



Art. 15/T
h 20 cm
l 15 cm

Art. 931
l 15 cm
p 1,7 cm

Art. 15/B
h 20 cm
l 15 cm

Art. 14
h 11,5 cm - l 22,5 cm - p 5,5 cm

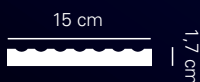

Art. 1315
h 22 cm - l 25 cm - p 5 cm



Art. 15/T
h 20 cm
l 15 cm

Art. 931
l 15 cm
p 1,7 cm

Art. 15/B
h 20 cm
l 15 cm

Art. 14
h 11,5 cm - l 22,5 cm - p 5,5 cm

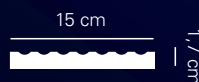

Art. 1250
h 10 cm - l 19 cm - p 6 cm



Art. 1136
h 12 cm
l 9 cm

Art. 2089
l 9 cm
p 1,5 cm

Art. 1136
h 12 cm
l 9 cm

Art. 1159
h 12,5 cm - l 13 cm - p 3,5 cm

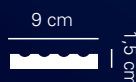

Art. 1638
h 21,5 cm - l 19,5 cm - p 5 cm



Art. 1136
h 12 cm
l 9 cm

Art. 2089
l 9 cm
p 1,5 cm

Art. 1136
h 12 cm
l 9 cm

Art. 1159
h 12,5 cm - l 13 cm - p 3,5 cm

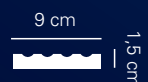



Art. 1291
h 19 cm - l 6,5 cm - p 6,5 cm

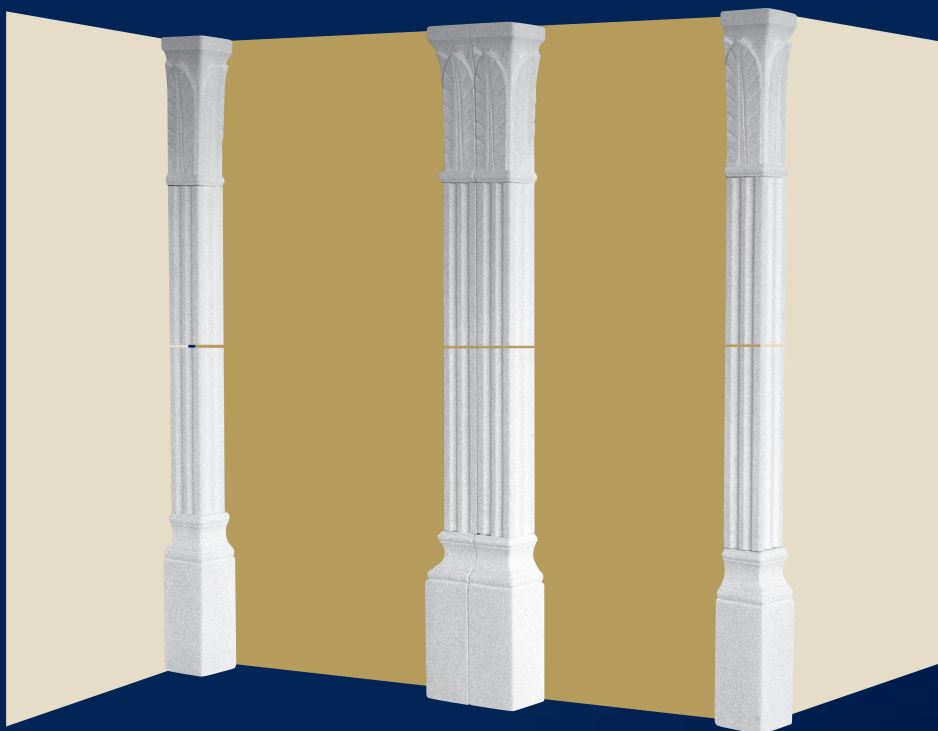

Art. 2144
5 x 5 cm

Modo di impiego degli articoli:
Examples of use:
1290 - 1291 - 2144

Art. 1290
h 21 cm
l 6,5 cm
p 6,5 cm



Hotel Alba - Pescara



Linea
Gesso

Gypsum Line

*Basi
e
Capitelli*

Bases and Capitals



Gelateria Acropolis - Colle di Val D'Elsa (SI)
Acropolis ice-cream parlour - Colle di Val D'Elsa (SI)

Villa privata - Yerevan (Armenia) - Private villa - Yerevan (Armenia)





Art. 1470
Capitello per lesena /
Capital for pilaster
h 67 cm
l 97 cm
p 25 cm

61,2 cm

8,2 cm



Art. 1246
h 53 cm
l 79 cm
p 39,5 cm

33 cm

37,5 cm



Art. 1437
h 4,5 cm
l 42 cm
p 21 cm

33 cm

42 cm



Art. 1335
Capitello per / capital for Art. 2179
Per colonna / for column ø 34 cm
h 42,5 cm
l 51 cm
p 51 cm



Art. 1589 1/4
1/4 di capitello / 1/4 capital for per Art. 2240



Art. 1589 a metà / half
semicapitello per / half-capital for Art. 2240
Per semicolonna / half-column ø 30,5 cm
h 21 cm
l 50 cm
p 25 cm



Art. 1443
Capitello per /
capital for Art. 2179
Per colonna / For column ø 34 cm
h 14 cm
l 45 cm
p 45 cm



Art. 387
semicapitello per colonna /
half-capital for column
ø 22 cm
h 28 cm - l 37 cm - p 18,5 cm



Art. 387/B
semibase per colonna /
half-base for column
ø 22 cm
h 26,5 cm - l 35 cm - p 17,5 cm



Art. 1057/35
h 22 cm
semibase per rivestimento pilastri
disponibile nei diametri interni /
Half-base for pilaster cladding
Available in internal diameters:
35 - 40 - 45 - 50 - 60 - 70 - 80 - 90 cm

Collari per colonne
Column collars



Art. 1669
ø int. 22 cm
ø est. 33,5 cm
h 8,5 cm



Art. 1670
ø int. 16 cm
ø est. 24,5 cm
h 6 cm



Art. 1671
ø int. 12 cm
ø est. 18 cm
h 4,5 cm



Art. 1672
ø int. 8 cm
ø est. 16 cm
h 3,5 cm

Per colonne ø 28 cm
For columns ø 28 cm



Art. 961
h 13 cm
l 50 cm
p 38 cm



Art. 1052
h 19 cm
l 45 cm
p 45 cm



Art. 960
h 31 cm
l 44 cm
p 44 cm



Art. 1051
h 34 cm
l 45 cm
p 45 cm

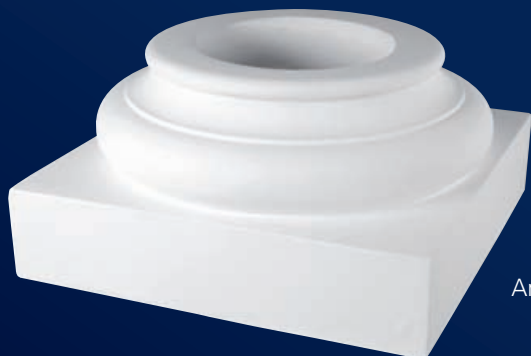

Art. 1026
h 23 cm
l 45 cm
p 45 cm



Art. 1050
h 29 cm
l 45 cm
p 45 cm

Per colonne ø 22 cm
For columns ø 22 cm



Art. 957
h 28 cm
l 37 cm
p 37 cm



Art. 1028
h 20 cm
l 40 cm
p 35 cm



Art. 954
h 26,5 cm
l 35 cm
p 35 cm



Art. 1027
h 14 cm
l 35 cm
p 35 cm



Art. 1049
h 21 cm
l 35 cm
p 35 cm



Per colonne ø 16 cm
For columns ø 16 cm



Art. 1201
h 26 cm
l 28 cm
p 28 cm



Art. 1055
h 13 cm
l 30 cm
p 30 cm



Art. 1200
h 25 cm
l 30,5 cm
p 30,5 cm



Art. 1053
h 17 cm
l 33 cm
p 31 cm



Art. 1640
h 16 cm
l 30 cm
p 30 cm



Art. 1054
h 17,5 cm
l 29 cm
p 29 cm

Per colonne ø 12 cm
For columns ø 12 cm



Art. 1194
h 10,5 cm
l 20 cm
p 20 cm



Art. 1195
h 16 cm
l 20 cm
p 20 cm

Per colonne ø 10 cm
For columns ø 10 cm



Art. 1048
h 17 cm
l 19 cm
p 19 cm



Art. 1352
h 9,5 cm
l 18 cm
p 18 cm



Art. 1351
h 12,5 cm
l 18 cm
p 18 cm

Per colonne ø 8 cm
For columns ø 8 cm



Art. 1354
h 9,5 cm
l 16 cm
p 16 cm



Art. 1353
h 12,5 cm
l 16 cm
p 16 cm

Semicapitelli per semicolonna Art. 2058
Half-capitals for half-column Art. 2058



Art. 1425/60 a metà / half
ø int. 60 cm
h 27,5 cm
l 106 cm
p 53 cm



Art. 1425/60 1/4
ø int. 60 cm



Art. 1425/50 a metà / half
ø int. 50 cm
h 25 cm
l 101 cm
p 50,5 cm



Art. 1425/50 1/4
ø int. 50 cm



Art. 1425/45 a metà / half
ø int. 45 cm
h 23,5 cm
l 86 cm
p 43 cm



Art. 1425/45 1/4
ø int. 45 cm



Art. 1425/40 a metà / half
ø int. 40 cm
h 20,5 cm
l 73 cm
p 36,5 cm



Art. 1425/40 1/4
ø int. 40 cm



Art. 1425/35 a metà / half
ø int. 35 cm
h 19 cm
l 60 cm
p 30 cm



Art. 1425/35 1/4
ø int. 35 cm



Showroom ASF Enterprise - Colle di Val d'Elsa (SI)

Villa privata - Yerevan (Armenia) - *Private villa - Yerevan (Armenia)*



Linea
Gesso

Gypsum Line

Colonne

Columns



Four Seasons Hotel - Firenze - *Four Seasons Hotel - Florence*

Tutti gli articoli possono essere realizzati sia in gesso bianco che, su richiesta, con finiture marmorizzate (campioni a pag 155)
All the articles are available in white gypsum plaster or, by request, with marbled finishes (samples on page 155)

Art. 1335
h 42,5 cm
l 51 cm
p 51 cm



Art. 2179
ø 29 cm



Art. 2179
ø 35 cm

Art. 1404
h 18 cm - ø est. 52 cm - ø int. 34 cm

Art. 1051
h 34 cm - l 45 cm - p 45 cm



Art. 2179
h 199 cm

Art. 2056
ø 28 cm

Art. 1050
h 29 cm - l 45 cm - p 45 cm



Art. 2056
ø 28 cm

Art. 960
h 31 cm - l 44 cm - p 44 cm



Art. 2056
ø 28 cm

Art. 1026
h 23 cm - l 45 cm - p 45 cm



Art. 2056
ø 28 cm



Art. 1052
h 19 cm - l 45 cm - p 45 cm



Art. 961
h 13 cm - l 50 cm - p 38 cm



Art. 1028
h 20 cm - l 40 cm - p 35 cm

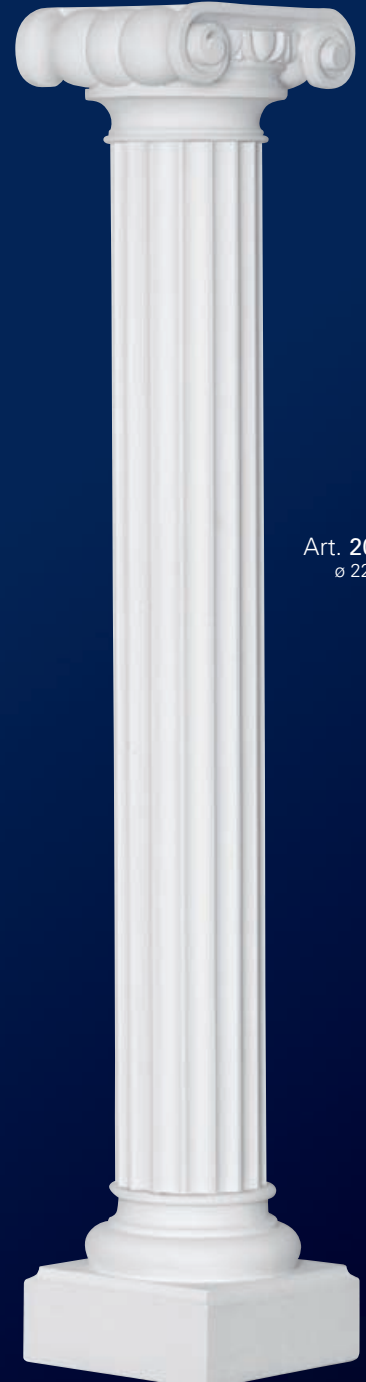

Art. 2189
ø 28 cm

Art. 2016
ø 28 cm

Art. 2052
ø 22 cm

Art. 1050
h 29 cm - l 45 cm - p 45 cm



Art. 2189
ø 28 cm

Art. 1026
h 23 cm - l 45 cm - p 45 cm



Art. 2016
ø 28 cm

Art. 954
h 26,5 cm - l 35 cm - p 35 cm



Art. 2052
ø 22 cm

Art. 957
h 28 cm - l 37 cm - p 37 cm



Art. 1027
h 14 cm - l 35 cm - p 35 cm



Art. 1200
h 25 cm - l 30,5 cm - p 30,5 cm



Art. 1053
h 17 cm - l 33 cm - p 31 cm



Art. 2001
ø 22 cm

Art. 2000
ø 22 cm

Art. 2286
ø 16 cm

Art. 2100
ø 16 cm

Art. 1049
h 21 cm - l 35 cm - p 35 cm



Art. 2001
ø 22 cm

Art. 1049
h 21 cm - l 35 cm - p 35 cm



Art. 2000
ø 22 cm

Art. 1640
h 16 cm - l 30 cm - p 30 cm



Art. 2286
ø 16 cm

Art. 1054
h 17,5 cm - l 29 cm - p 29 cm



Art. 2100
ø 16 cm



Art. 1055
h 13 cm - l 30 cm - p 30 cm



Art. 1201
h 26 cm - l 28 cm - p 28 cm



Art. 1194
h 10,5 cm - l 20 cm - p 20 cm



Art. 1194
h 10,5 cm - l 20 cm - p 20 cm



Art. 2057
ø 16 cm

Art. 2057
ø 16 cm

Art. 2284
ø 12 cm

Art. 2278
ø 12 cm

Art. 1054
h 17,5 cm - l 29 cm - p 29 cm



Art. 2057
ø 16 cm

Art. 1640
h 16 cm - l 30 cm - p 30 cm



Art. 2057
ø 16 cm

Art. 1195
h 16 cm - l 20 cm - p 20 cm



Art. 2284
ø 12 cm

Art. 1195
h 16 cm - l 20 cm - p 20 cm



Art. 2278
ø 12 cm

Art. 1194
h 10,5 cm - l 20 cm - p 20 cm



Art. 1195
h 16 cm - l 20 cm - p 20 cm



Art. 2117
ø 12 cm

Art. 1048
h 17 cm - l 19 cm - p 19 cm

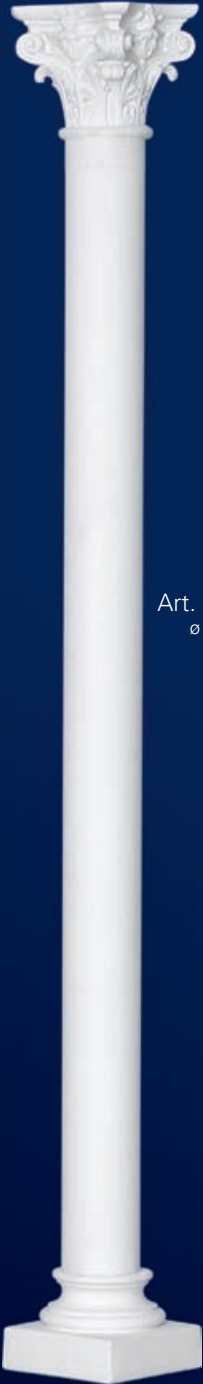

Art. 1351
h 12,5 cm - l 18 cm - p 18 cm



Art. 2177
ø 10 cm

Art. 1352
h 9,5 cm - l 18 cm - p 18 cm



Art. 1351
h 12,5 cm - l 18 cm - p 18 cm



Art. 2177
ø 10 cm

Art. 1354
h 9,5 cm - l 16 cm - p 16 cm

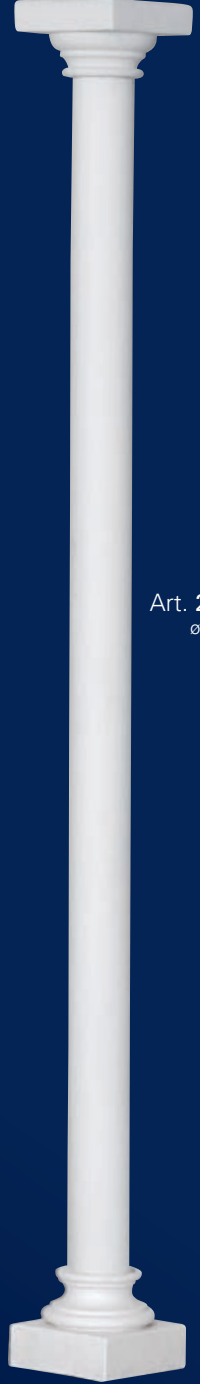

Art. 1353
h 12,5 cm - l 16 cm - p 16 cm



Art. 2176
ø 8 cm

Art. 2117
ø 12 cm

Art. 2177
ø 10 cm

Art. 2177
ø 10 cm

Art. 2176
ø 8 cm



Ristorante da Iva - Bucchianico (CH)



Abitazione privata - Firenze - *Private home - Florence*

Linea
Gesso

Gypsum Line

Semicolonne

Half-columns



Four Seasons Hotel - Firenze - *Four Seasons Hotel - Florence*

Hotel Alba - Pescara



Tutti gli articoli sono realizzati in altezza di 200 cm
All the articles are 200 cm in height



Art. 2059
ø 28 cm

Art. 2004
ø 28 cm

Art. 2186
ø 28 cm

Art. 940
ø 22 cm

Art. 646/B
ø 22 cm

Art. 937
ø 22 cm

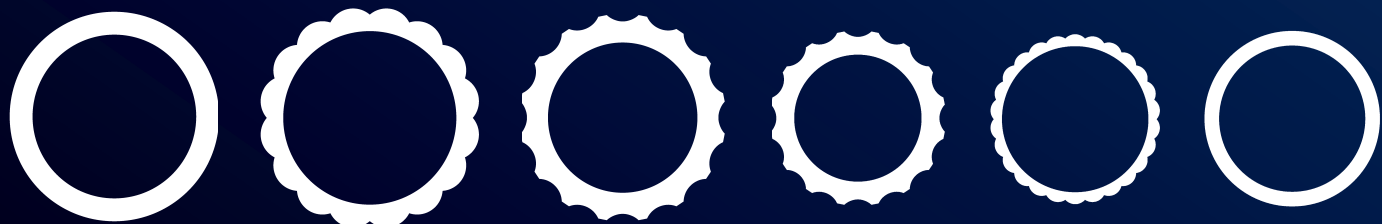

Art. 2056
ø 28 cm

Art. 2016
ø 28 cm

Art. 2189
ø 28 cm

Art. 2052
ø 22 cm

Art. 2000
ø 22 cm

Art. 2001
ø 22 cm



Art. 2020
ø 16 cm



Art. 2060
ø 16 cm



Art. 2285
ø 16 cm



Art. 2116
ø 12 cm



Art. 2283
ø 12 cm



Art. 2279
ø 12 cm



Art. 2166
ø 10 cm



Art. 2158
ø 8 cm



Art. 2100
ø 16 cm



Art. 2057
ø 16 cm



Art. 2286
ø 16 cm



Art. 2117
ø 12 cm



Art. 2284
ø 12 cm



Art. 2278
ø 12 cm



Art. 2177
ø 10 cm



Art. 2176
ø 8 cm



Art. 2287
h 248 cm

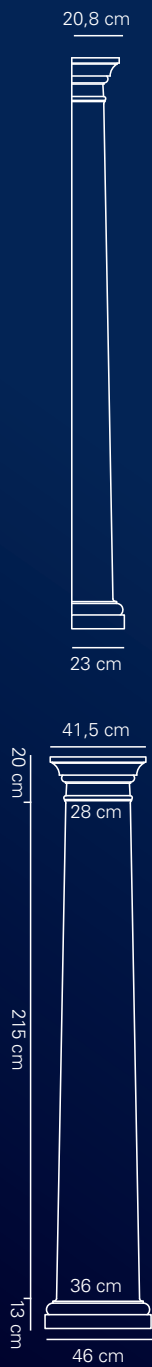

Art. 2288
h 192 cm

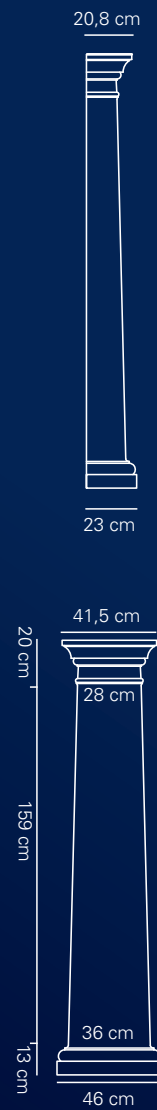

Art. 2289
h 101 cm





Art. 1425/40 a metà
Semicapitello per rivestimento pilastri
disponibile nei diametri interni /
Half-capital for pilaster cladding
Available in internal diameters:
35 - 40 - 45 - 50 - 60 cm
vedi pag 134 / see pag 134

Art. 2058/40
Semicolonna
per rivestimento pilastri
disponibile
nei diametri esterni /
Half-capital for pilaster
cladding
Available in external
diameters:
35 - 40 - 45 - 50 - 60 -
70 - 80 - 90 cm

Art. 1057/40
h 22 cm
semibase per rivestimento pilastri
disponibile nei diametri interni /
Half-base for pilaster cladding
Available in internal diameters:
35 - 40 - 45 - 50 - 60 - 70 - 80 - 90 cm



Art. 2058/40
ø est. 40 cm



Art. 1589 a metà / half
h 21 cm
l 50 cm
p 25 cm

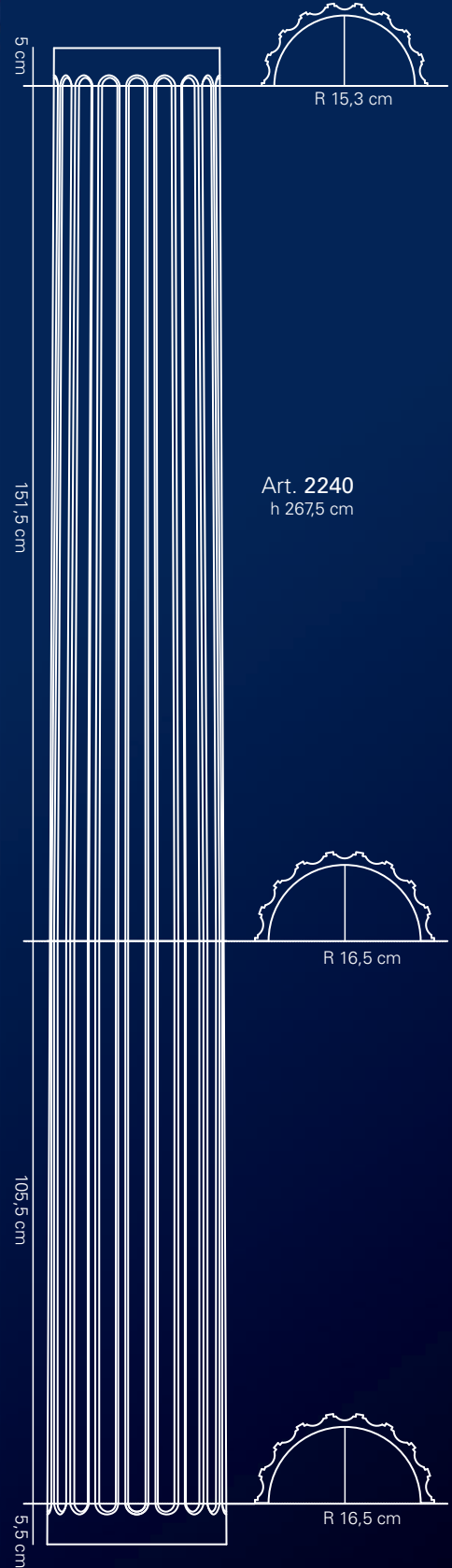

Art. 2240
h 267,5 cm

Art. 1575
h 18 cm
ø est. 48 cm
ø int. 30 cm

Linea
Gesso

Gypsum Line

*Complementi
d'arredo*

Decorating Complements



Abitazione privata - Firenze
Private home - Florence



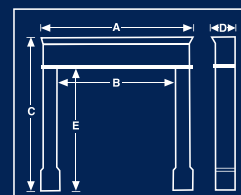

Art. FS/17
A = 160 cm
B = 101,5 cm
C = 123 cm
D = 30 cm
E = 90 cm

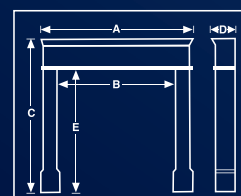

Art. FS/10
A = 120 cm
B = 83 cm
C = 108 cm
D = 14 cm
E = 81 cm

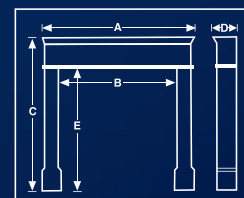

Art. FS/11
A = 130 cm
B = 85 cm
C = 113 cm
D = 15 cm
E = 86 cm

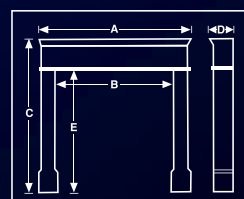

Art. FS/14
A = 137 cm
B = 88 cm
C = 111 cm
D = 16 cm
E = 83 cm

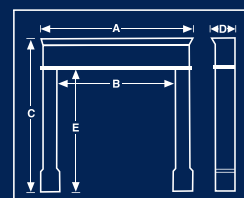

Art. FS/15 SATINATO

A = 160 cm
B = 92 cm
C = 125 cm
D = 26 cm
E = 91 cm

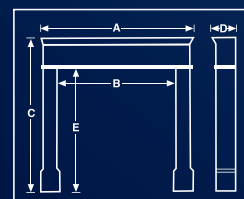

Art. FS/16 SIENA

A = 144 cm
B = 81 cm
C = 114 cm
D = 26 cm
E = 87 cm



Art. 2002
Grigio Rosso
h 75 cm - ø 22 cm
capitello / capital
h 28 cm - 37 x 37 cm
base
h 21 cm - 35 x 35 cm



Art. 2044
Bianco Chiara
h 75 cm - ø 22 cm
capitello / capital
h 28 cm - 37 x 37 cm
base
h 21 cm - 35 x 35 cm

Campioni marmorizzati / Marble-finish samples

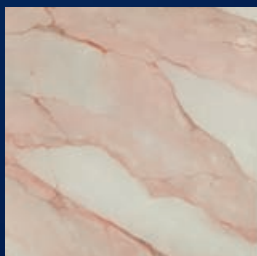

Grigio Rosso

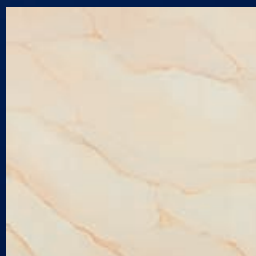

Rosa Portogallo

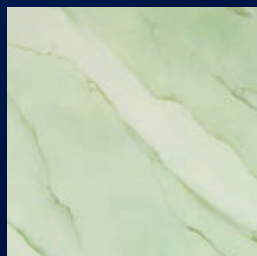

Verde Acqua



Giallo Siena

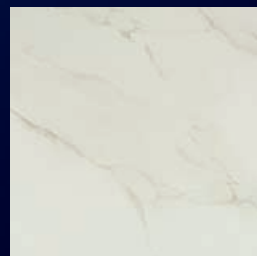

Bianco Carrara

Gli specchi vengono forniti solo su richiesta.
Mirrors available by request only.



Art. 1329
h 72 cm
l 116 cm
p 9 cm



Art. S1
67 x 43 cm



Art. 1222
34,5 x 24 cm



Art. S4
53 x 32 cm



Art. 1020
56 x 36 cm



Art. S3
36 x 30 cm



Art. 1553
h 99 cm
l 86 cm
p 6,5 cm



Art. 1327
58 x 48 cm



Art. 1322
66 x 54 cm



Art. 1038
88 x 67 cm



Art. 75
67 x 46 cm

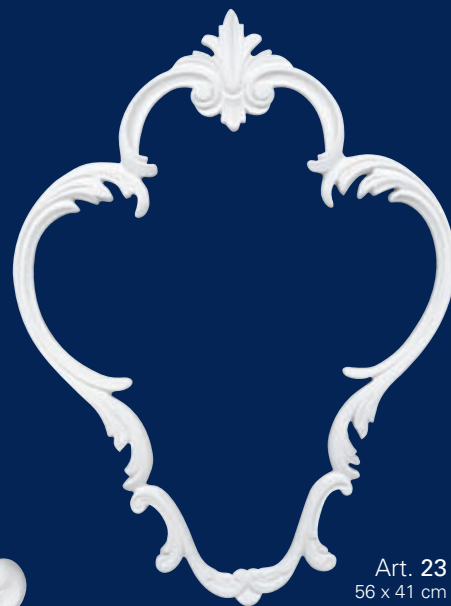

Art. 23
56 x 41 cm

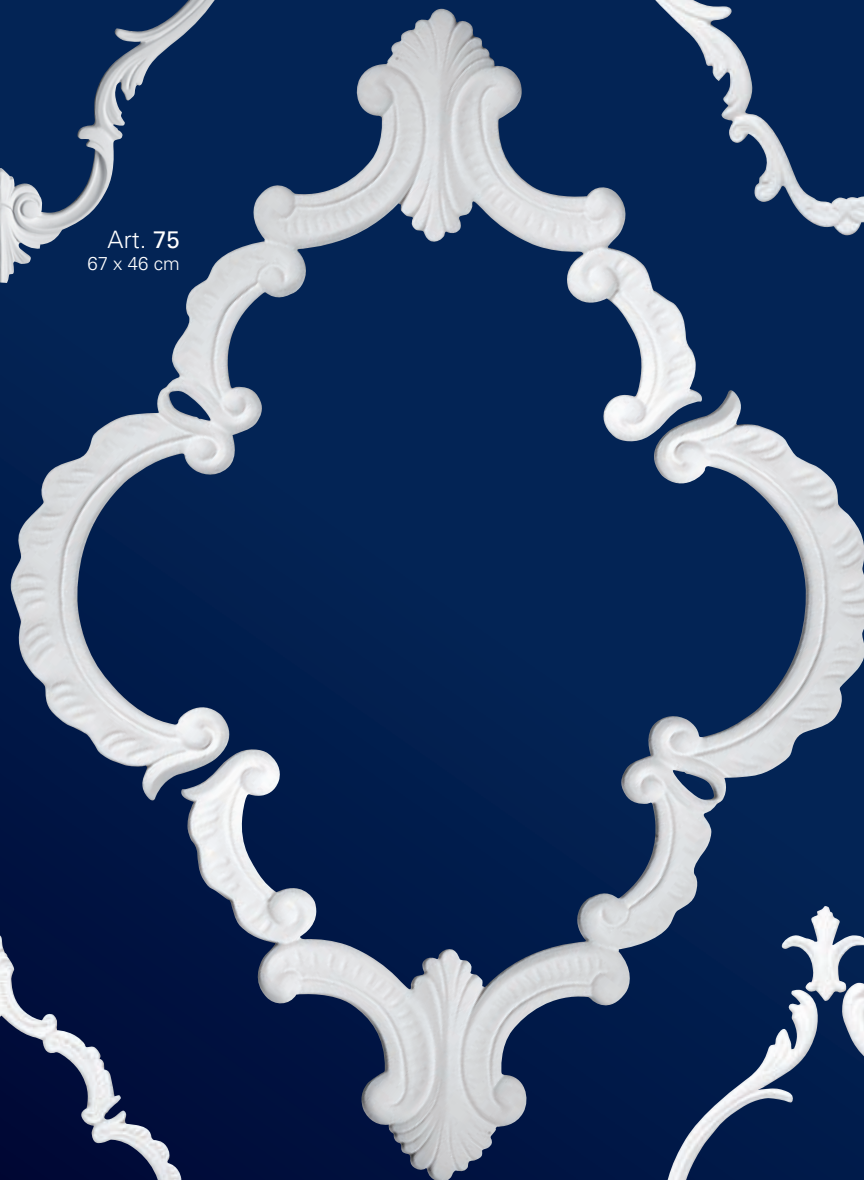

Art. 1062
(1 completo
composto da 2 pezzi)
(1 set composed of 2 pieces)
110 x 80 cm



Art. 357
52 x 36 cm



Art. 28
(1 completo
composto da 4 pezzi)
(1 set composed of 4 pieces)
52 x 30 cm



Art. 1339
h 29 cm - l 95 cm - p 15 cm



Art. 1220
h 32 cm - l 18 - p 10 cm



Art. 1221
h 32 cm - l 20 - p 10 cm



Art. 1149
h 11,5 cm - l 20 cm - p 5,5 cm



Art. 1303
h 14 cm - l 14 cm - p 7 cm



Art. 1302
h 14 cm - l 14 cm - p 6 cm



Art. 359
h 27 cm - l 24 - p 11 cm



Art. 1103
h 28 cm - l 13 - p 9 cm



Art. 1102
h 28 cm - l 14,5 - p 9 cm



Art. 1300
h 10 cm - l 14 cm - p 6 cm



Art. 1301
h 10 cm - l 14 cm - p 6 cm



Art. 494/C
h 12 cm - l 7 cm
p 3,5 cm



Art. 494/A
h 12 cm - l 7 cm
p 3,5 cm



Art. 1209
h 26 cm - l 23 - p 13 cm



Art. 1503
h 20 cm - l 21 - p 7 cm



Art. 494/V
h 12 cm - l 7 cm
p 3,5 cm



Art. 494/F
h 12 cm - l 7 cm
p 3,5 cm



Art. 1528
22 x 79 cm



Art. 1387
h 107 cm - l 33 cm - p 5 cm



Art. 1648
19,5 x 33,5 cm



Art. 1399
h 107 cm - l 18,5 cm - p 5 cm



Art. 1653
17 x 117 cm



Art. 1098
ø 20 cm
h 35 cm



Art. 1225
h 69 cm - l 46 - p 30 cm



Art. 1270
h 77 cm - l 32 - p 26 cm



Art. 1269
h 85 cm - l 26 - p 19 cm

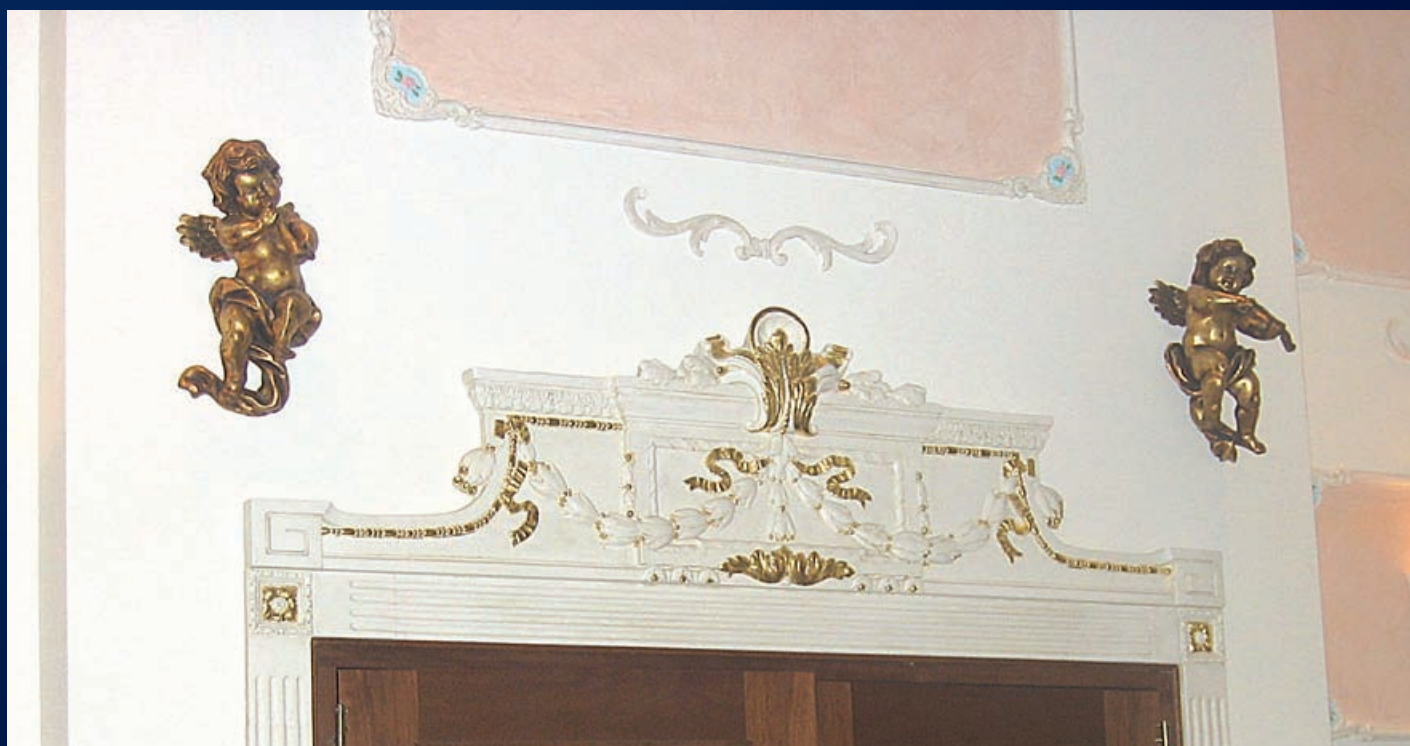

Hotel Alba - Pescara

Linea
Gesso

Gypsum Line

Elementi

Vari

Various Elements



Villa Privata - Yerevan (Armenia)
Private villa

Stand Anik+ - Mosca
Anik+ Stand - Moscow





55 cm

Art. 35
h 50 cm
l 65 cm



50 cm

Art. 1451
h 48 cm
l 69 cm



35 cm

Art. 1453
h 39 cm
l 47 cm



46 cm

Art. 1035
h 37,5 cm
l 64 cm



30 cm

Art. 82
h 23 cm
l 40,5 cm



Art. 1472
h 19 cm
l 40 cm



Art. 7
h 22 cm
l 34 cm



Art. 81
h 14 cm
l 25 cm



Art. 8
h 20 cm
l 32 cm



Art. 436
h 16 cm
l 32 cm

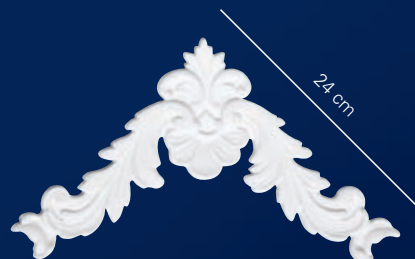

Art. 1161
h 19 cm
l 32,5 cm



Art. 4
h 19 cm
l 36 cm



Art. 3
h 11 cm
l 28 cm



Art. 1261
h 20 cm
l 25 cm



Art. 2
h 13 cm
l 32 cm



Art. 36
h 13 cm
l 20 cm



Art. 1034
h 27 cm
l 51 cm

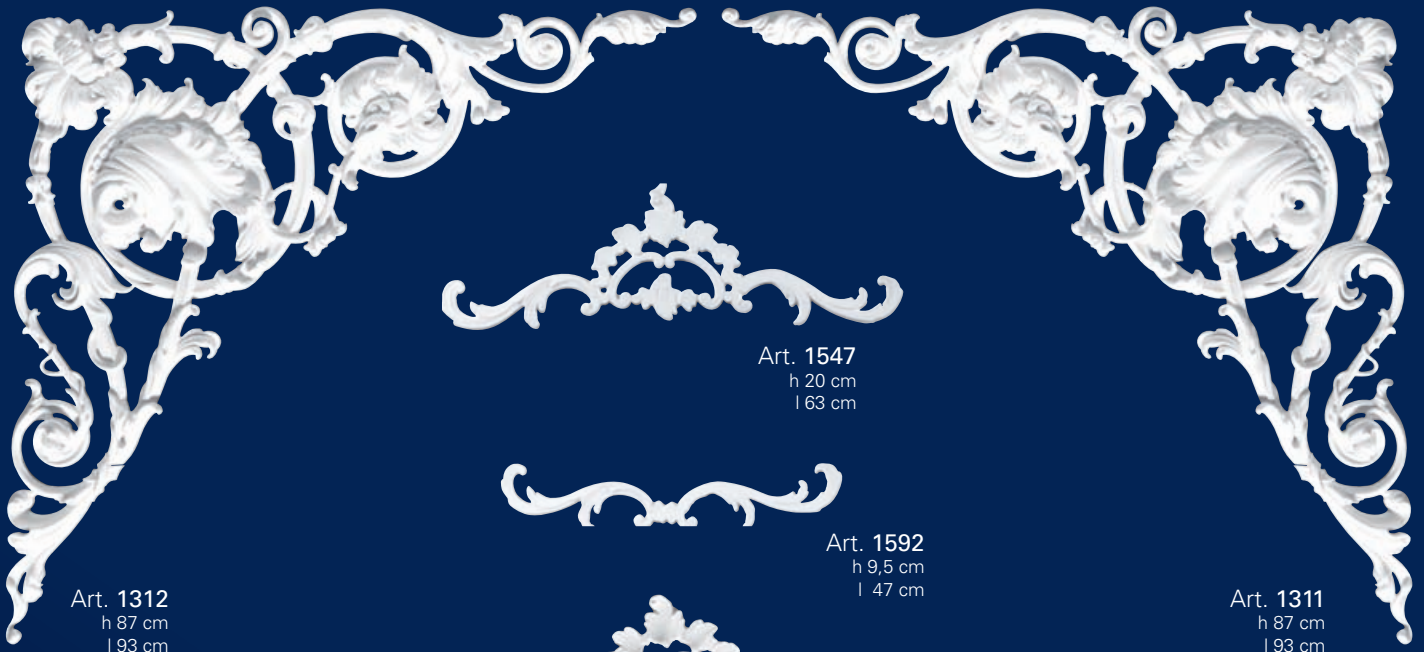

Art. 1312
h 87 cm
l 93 cm

Art. 1547
h 20 cm
l 63 cm

Art. 1592
h 9,5 cm
l 47 cm

Art. 1311
h 87 cm
l 93 cm

Art. 1570
h 29 - l 52
lato / side 38 cm

Art. 1389
h 38 cm
l 66 cm
p 8 cm



Art. 1388
h 38 cm
l 66 cm
p 8 cm



Art. 1645/S

Art. 1645/C
tot. h 35 cm
l 162 cm

Art. 1645/D



Art. 1545
h 24 cm
l 86 cm



Art. 1621
12 x 81 cm



Art. 1622
12 x 81 cm



Art. 1627
12 x 106 cm



Art. 1628
12 x 106 cm



Art. 1624
12 x 106 cm



Art. 1625
12 x 106 cm



Art. 1548/S

Art. 1548/C
tot. 39 x 126 cm

Art. 1548/D



Art. 1546
26 x 125 cm



Art. 1668
102 x 7 cm



Art. 1019
h 46 cm
l 50 cm



Art. 1179
37 x 86 cm



Art. 1018
20 x 55 cm



Art. 1253
24,5 x 18 cm



Art. 1241
21 x 52 cm

Art. 1242
33 x 18 cm



Art. 1614
44 x 25 cm



Art. 1613
44 x 25 cm



Art. 1616
48 x 18 cm



Art. 1617
48 x 18 cm



Art. 1607
50 x 36 cm



Art. 1608
50 x 36 cm



Art. 1611
26 x 13 cm



Art. 1612
26 x 13 cm



Art. 1610
38 x 105 cm



Art. 1567
h 29 cm
l 30 cm



Art. 441
6 x 40 cm

Esempio di uso ripetuto / Example of serial application of Art. 1544



Art. 1551
18 x 7,5 cm





Art. 1615
27,5 x 59 cm



Art. 1541
15 x 18,5 cm



Art. 1609
28 x 52,5 cm



Art. 1630
42 x 42 cm



Art. 1626
29 x 61 cm



Art. 182
17 x 120 cm



Art. 183
17 x 120 cm



Art. 197
14 x 80 cm



Art. 198
14 x 80 cm



Art. 486
16 x 71 cm



Art. 189
9 x 40 cm

Art. 422
12 x 5 cm

Art. 188
9 x 40 cm



Art. 193
10 x 50 cm

Art. 423
20 x 11 cm

Art. 192
10 x 50 cm



Art. 1089
h 79,5 cm
l 33,5 cm
p 50 cm



Art. 1355
h 82 cm
l 23 cm
p 21,5 cm



Art. 1155
h 43,5 cm
l 33 cm
p 24,5 cm



Art. 1595
h 71 cm
l 38 cm
p 44 cm



Art. 1197
h 71,5 cm
l 28 cm
p 40 cm



Art. 1406
h 35,5 cm
l 43,5 cm
p 9 cm



Art. 1331
h 32 cm
l 48 cm
p 21 cm



Art. 1166
h 27 cm
18 x 18 cm



Art. 1457
h 65,5 cm - l 27 cm - p 12,5 cm



Art. 1304
h 52 cm - l 30 cm - p 21 cm



Art. 1157
h 26 cm
l 34 cm
p 15,5 cm



Art. 448
h 33 cm
l 32 cm
p 16 cm



Art. 1356
h 54 cm
l 22,5 cm
p 20 cm



Art. 1364
h 46 cm
l 20,5 cm
p 19 cm



Art. 11
h 44,5 cm
l 17 cm
p 19,5 cm



Art. 348
h 40 cm
l 14 cm
p 8 cm



Art. 239
h 31 cm
l 13,5 cm
p 15 cm



Art. 1061
h 31 cm
l 26 cm
p 17 cm



Art. 240
h 30,5 cm
l 25,5 cm
p 22,5 cm



Art. 412
h 28,5 cm
l 24,5 cm
p 18,5 cm



Art. 1584
h 30,5 cm
l 24 cm
p 22 cm



Art. 1500
h 30 cm
l 12,5 cm
p 9 cm



Art. 235
h 30 cm
l 23,5 cm
p 10,5 cm



Art. 499
h 27,5 cm
l 19,5 cm
p 13 cm



Art. 421
h 26,5 cm
l 16 cm
p 12 cm



Art. 1199
h 26 cm
l 22 cm
p 11,5 cm



Art. 428
h 25 cm
l 12 cm
p 9 cm



Art. 447
h 24 cm
l 21,5 cm
p 6,5 cm



Art. 350
h 21 cm - l 14,5 cm
p 7,5 cm



Art. 349
h 17 cm - l 10,5 cm
p 9 cm



Art. 1392
h 17 cm - l 12,5 cm
p 6,5 cm



Art. 462
h 16 cm - l 8 cm
p 12,5 cm



Art. 417
h 14 cm - l 10 cm
p 8 cm



Art. 451
h 11,5 cm - l 12 cm
p 11 cm



Art. 438
ø 20 cm



Art. 55
ø 16 cm



Art. 37
ø 12,5 cm



Art. 1496
ø 9 cm



Art. 465
ø 15,5 cm



Art. 427
ø 7 cm



Art. 65
ø 15 cm



Art. 1540
18 x 11 cm



Art. 457
ø 15,5 cm



Art. 1022
ø 12 cm



Art. 48
ø 7 cm



Art. 26
ø 6,5 cm



Art. 488
ø 14 cm



Art. 25
ø 6,5 cm



Art. 40
ø 6,5 cm



Art. 41
ø 6,5 cm



Art. 1009
ø 12,5 cm



Art. 32
ø 5 cm



Art. 56
5 x 5 cm



Art. 1260
ø 10,5 cm



Art. 44
ø 18 cm



Art. 1494
ø 15 cm



Art. 1021
ø 12 cm



Art. 30
ø 10 cm



Art. 1350
ø 9 cm



Art. 1444
ø 9 cm



Art. 47
ø 4,5 cm



Art. 489
ø 9,5 cm



Art. 67
ø 17 cm



Art. 1495
ø 15 cm



Art. 31
ø 9 cm



Art. 1446
ø 4 cm



Art. 54
ø 6 cm



Art. 42
ø 17 cm



Art. 425
ø 14 cm



Art. 1642
ø 4 cm



Art. 1641
ø 6 cm



Art. 1403
ø 10 cm



Art. 1402
ø 12,5 cm



Art. 24
ø 13 cm



Art. 38
13 x 13 cm



Art. 1154
10,2 x 10,2 cm



Art. 1436
10 x 10 cm



Art. 89
6 x 6 cm



Art. 1497
4,7 x 5,5 cm



Art. 1445
3,5 x 3,5 cm



Art. 1433

ø cm



2,3



2,1



1,9



1,3



1

Nicchie angolari
Corner niches



Art. 414
h 23 cm
15 x 15 cm



Art. 1072
h 21,5 cm
23 x 23 cm



Art. 1651
h 20,5 cm
16,5 x 16,5 cm



Art. 1002
h 23 cm
l 31 cm
p 14 cm



Art. 1594
h 24 cm
l 27 cm
p 14 cm



Art. 493
h 22 cm
l 34 cm
p 11,5 cm



Art. 411
h 21 cm
l 32 cm
p 14 cm



Art. 1076
h 12 cm
l 56 cm
p 23 cm



Art. 1153
h 13,5 cm
l 45 cm
p 22 cm



Art. 1647
h 21 cm
l 41,5 cm
p 20,5 cm



Art. 1001
h 15 cm
l 30 cm
p 15 cm



Art. 1332
h 11,5 cm
l 29 cm
p 14 cm



Art. 1243
h 12 cm
l 34 cm
p 15 cm



Art. 1326
h 10,5 cm
l 30 cm
p 15 cm



Art. 1265
h 13 cm
l 35 cm
p 13 cm



Art. 1330
h 12,5 cm
l 32,5 cm
p 14 cm



Art. 1244
h 10,5 cm
l 21 cm
p 11 cm



Nicchie realizzate in gesso speciale con chiusura posteriore per un pratico fai da te
Niches in special plaster, with rear closure for practical DIY



Art. 1430
h 23 cm
l 42 cm
p 18 cm



Art. 1181
h 11,5 cm
l 41 cm
p 16,5 cm



Art. 1442
h 15 cm
l 39 cm
p 20 cm



Art. 1182
h 12 cm
l 30,5 cm
p 14 cm



Art. 1593
h 16 cm
l 40,5 cm
p 21 cm



Art. 1186
h 15 cm
l 30 cm
p 15 cm



Art. 1185
h 15 cm
l 32 cm
p 15,5 cm



Art. 1184
h 17,5 cm
l 37 cm
p 17,5 cm

Nicchie angolari realizzate in gesso speciale con chiusura posteriore per un pratico fai da te
Corner niches in special plaster, with rear closure for practical DIY



Art. 1522
h 22,5 cm
19 x 19 cm



Art. 1523
h 24 cm
20 x 20 cm



Art. 1524
h 21 cm
16 x 16 cm



Art. 1365
21 x 21 cm



Art. 1505
19 x 19 cm

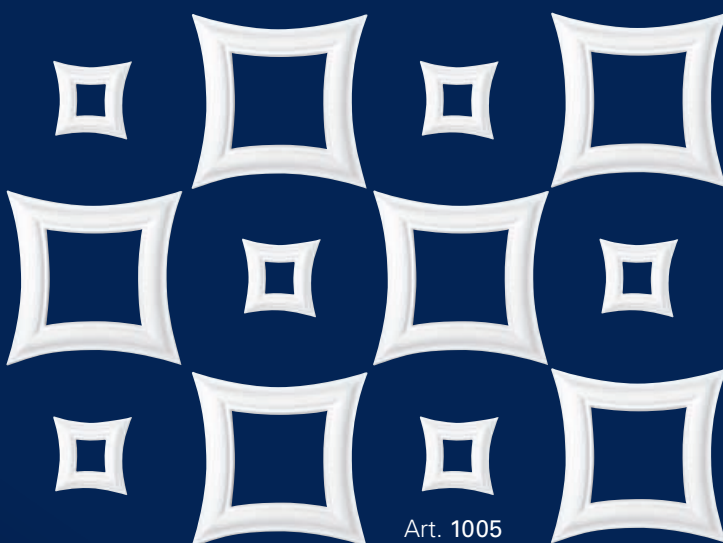

Art. 1005
9,5 x 9,5 cm
diag. 13 cm

Art. 1006
21,5 x 21,5 cm
diag. 30 cm

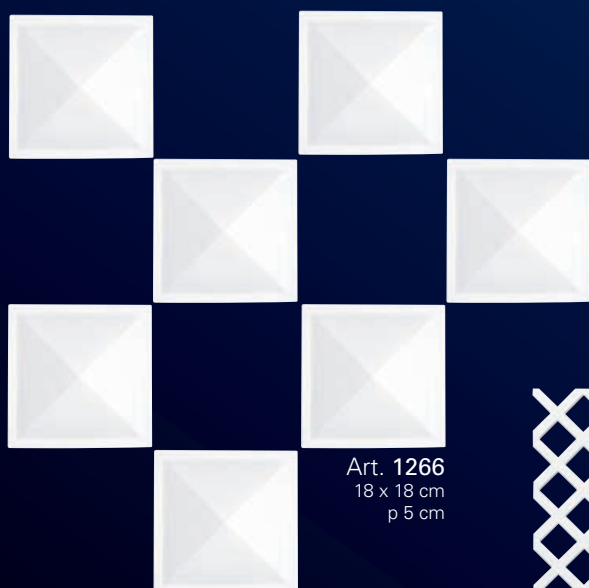

Art. 1266
18 x 18 cm
p 5 cm

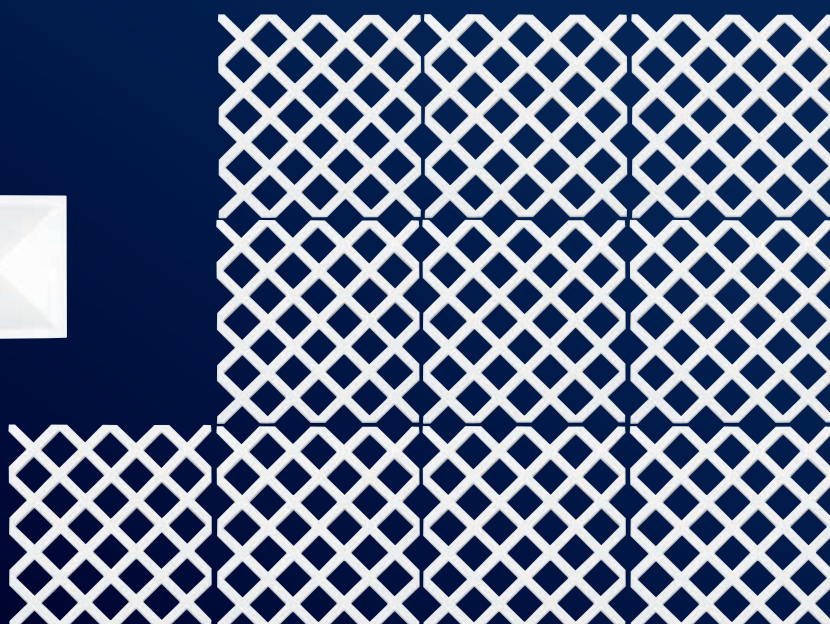

Art. 1463
25 x 25
p 1,2 cm



Art. 1456
52,5 x 52,5 cm
p 2,8 cm



Art. 1650
est. 56 x 56 cm
int. 31 x 31 cm
p 6 cm



Art. 1467
40 x 40 cm
p 1,2 cm



Art. 1468
40 x 40 cm
p 1,2 cm



Art. 1469
40 x 40 cm
p 2 cm

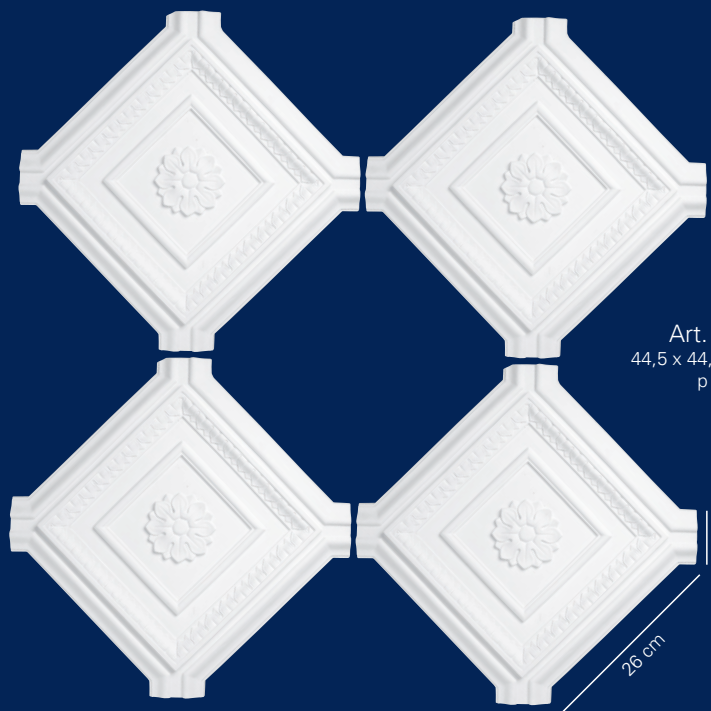

Art. 325
44,5 x 44,5 cm
p 2 cm



Art. 307
35 x 35 cm
p 1 cm



Abitazione privata - Firenze
Private home - Florence

Le composizioni dei componibili sono indicate nel listino prezzi
The modular compositions are itemized in the price list



Art. 489

Art. 265
1 pezzo / piece 9 x 28 cm
(composto da 4 pezzi)
(composed of 4 pieces)



Art. 37



Art. 48



Art. 54

Art. 266
1 pezzo / piece 12 x 22,5 cm
(composto da 4 pezzi)
(composed of 4 pieces)



Art. 208

Art. 394
tot. 75 x 64 cm
(composto da 2 pezzi)
(composed of 2 pieces)



Art. 264
1 pezzo / piece 18 x 35 cm
(composto da 4 pezzi)
(composed of 4 pieces)



Art. 24

Art. 337
(1 pezzo / piece)
51 x 27 cm



Art. 1567
(1 pezzo / piece)
29 x 30 cm

Art. 1569
(1 pezzo / piece)
15,5 x 40 cm



Art. 67

Art. 335
(1 pezzo / piece)
48 x 80 cm

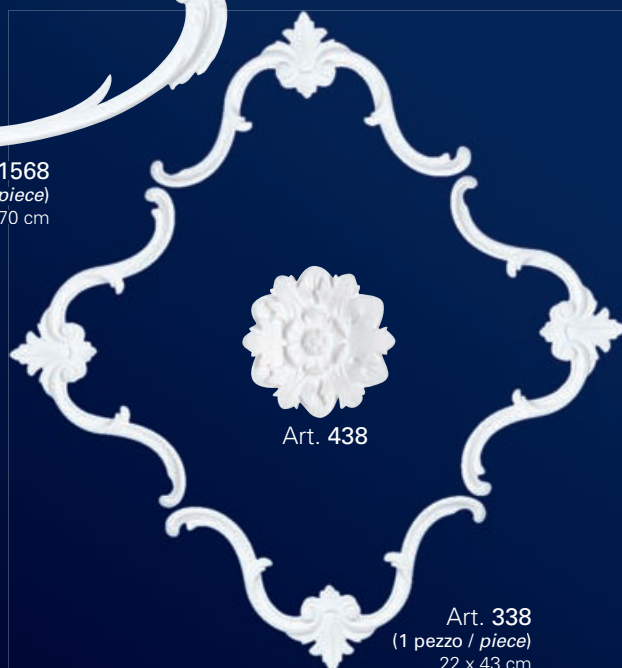

Art. 438

Art. 338
(1 pezzo / piece)
22 x 43 cm

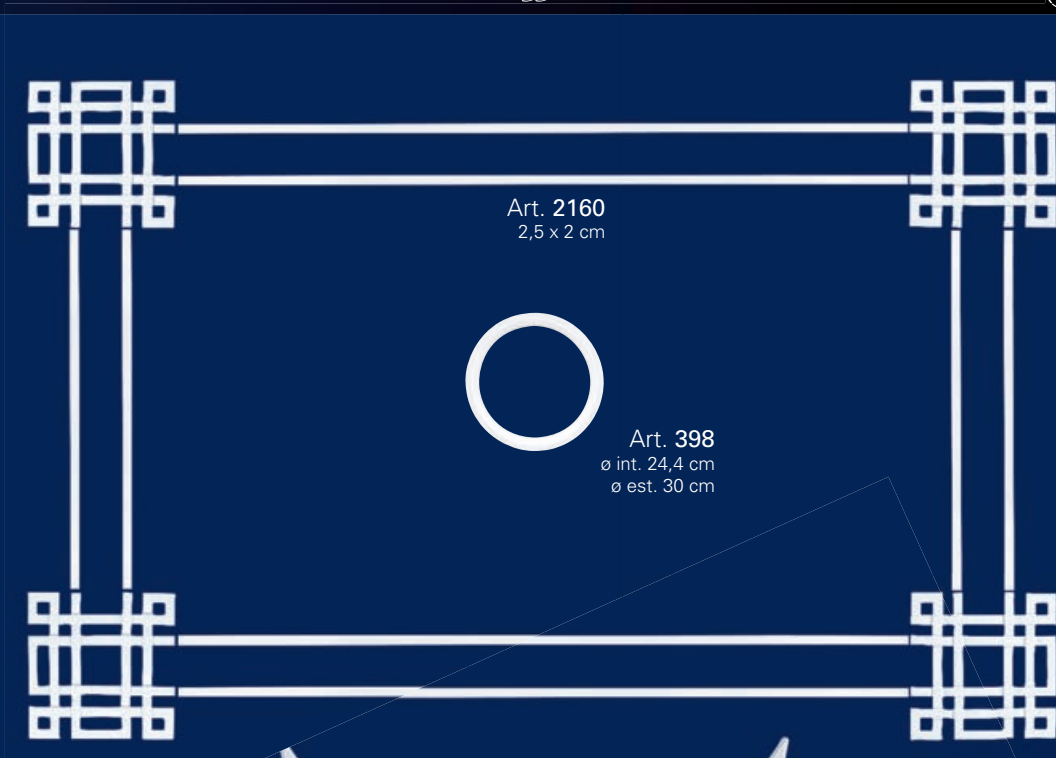

Art. 2160
2,5 x 2 cm

Art. 398
ø int. 24,4 cm
ø est. 30 cm

Art. 1432
31 x 31 cm



Art. 1393
58 x 58 cm

Art. 1372
Composto da 8 pezzi
Composed of 8 pieces
est. 315 x 315 cm
con cornice / with frame Art. 934



Art. 2173
10,5 x 3,7 cm

Art. 1004
100 x 70 cm

Art. 1373

300 x 150 cm
Composto da 4 pezzi
Composed of 4 pieces
Prolungabile con cornice /
Can be prolonged with frame Art. 2173



Art. 249
82 x 67 cm

Art. 395

Composto da 4 pezzi
Composed of 4 pieces
tot. est. 158 x 106 cm
tot. int. 151 x 99 cm
con cornice / *with frame Art. 2022*

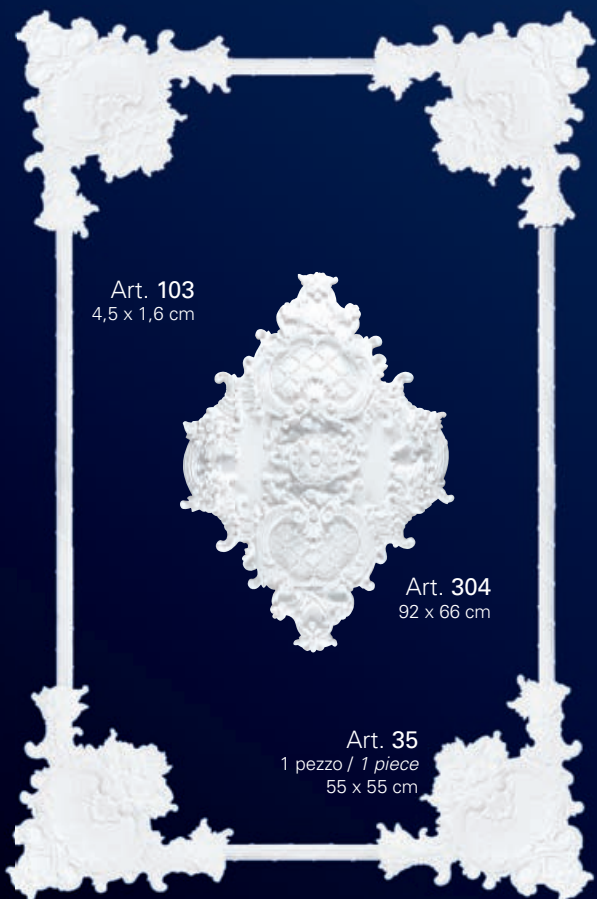

Art. 103
4,5 x 1,6 cm



Art. 304
92 x 66 cm

Art. 35
1 pezzo / 1 piece
55 x 55 cm

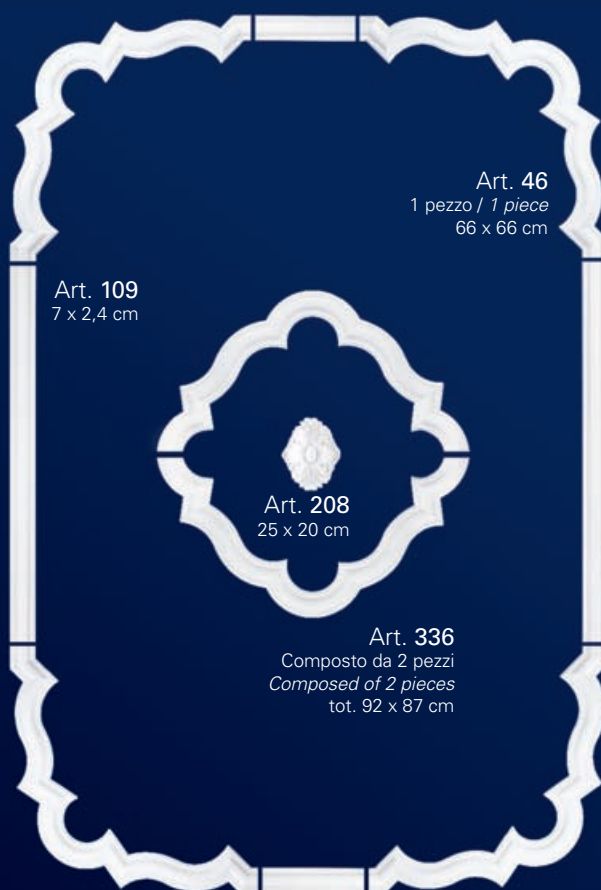

Art. 46
1 pezzo / 1 piece
66 x 66 cm

Art. 109
7 x 2,4 cm



Art. 208
25 x 20 cm

Art. 336
Composto da 2 pezzi
Composed of 2 pieces
tot. 92 x 87 cm

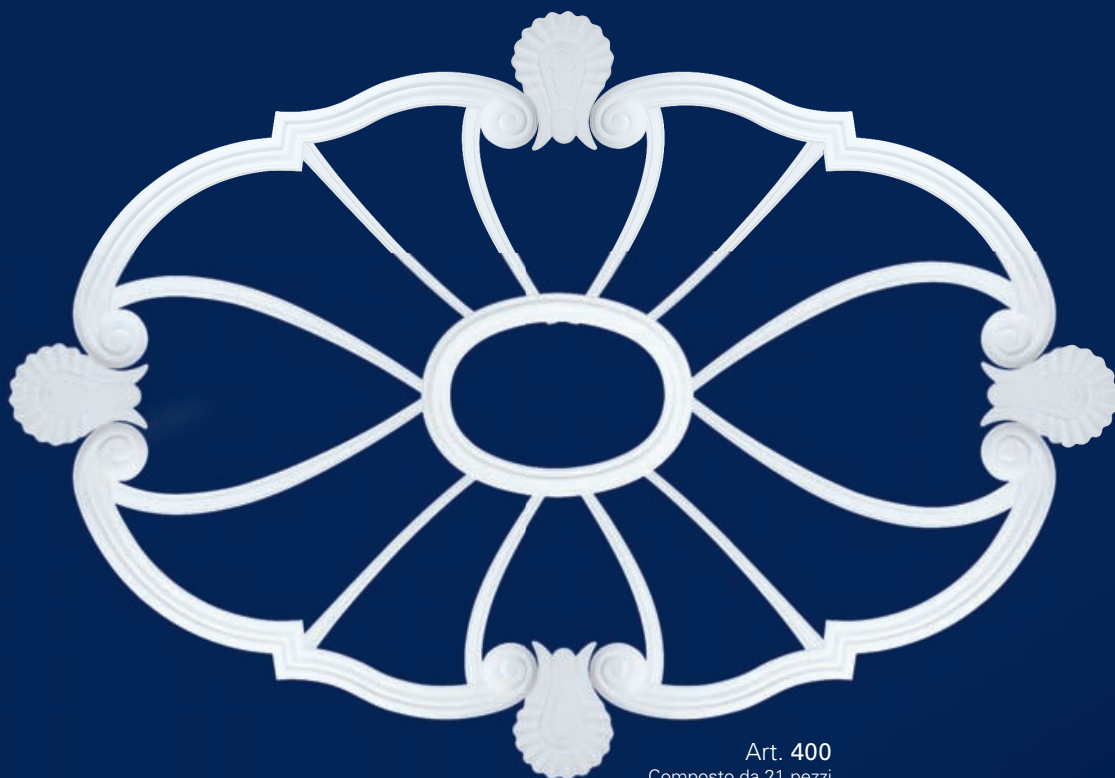

Art. 400
Composto da 21 pezzi
Composed of 21 pieces
tot. 240 x 300 cm

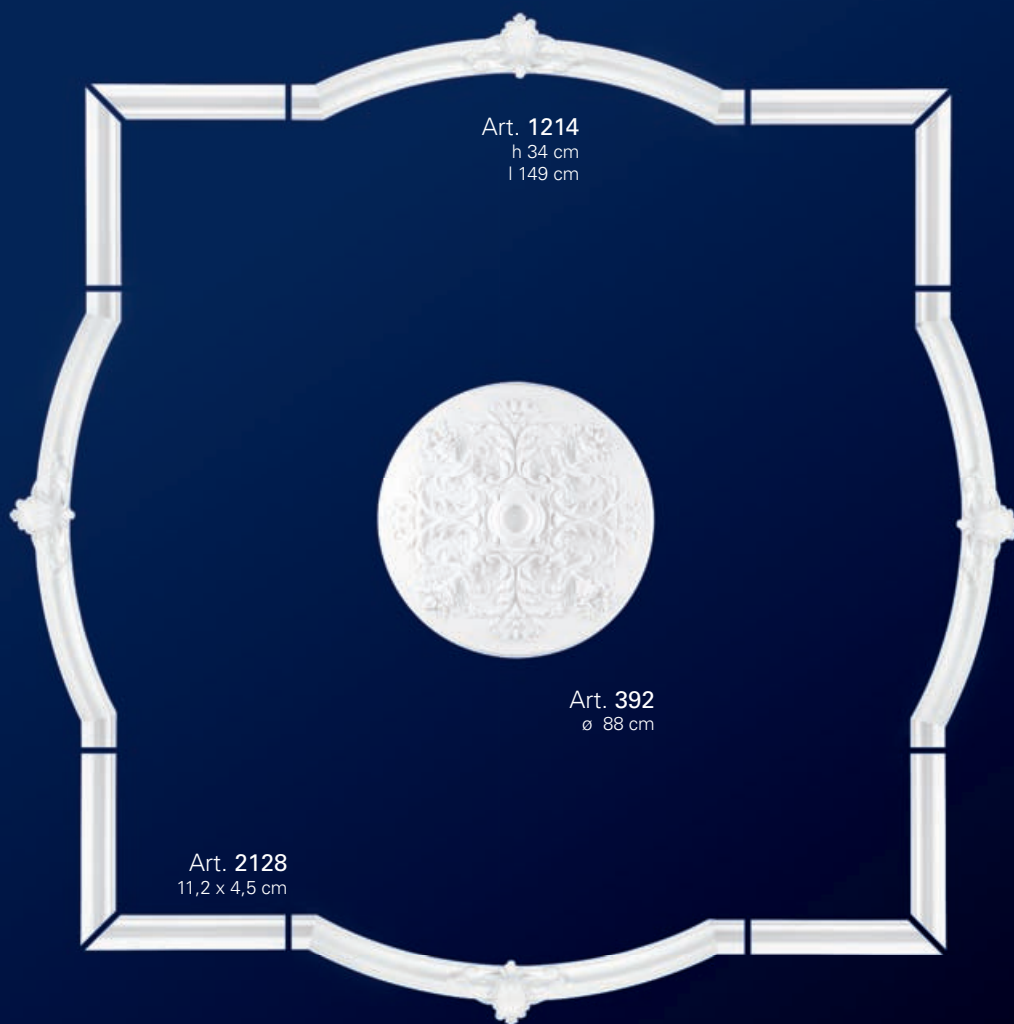

Art. 1214
h 34 cm
l 149 cm

Art. 392
ø 88 cm

Art. 2128
11,2 x 4,5 cm

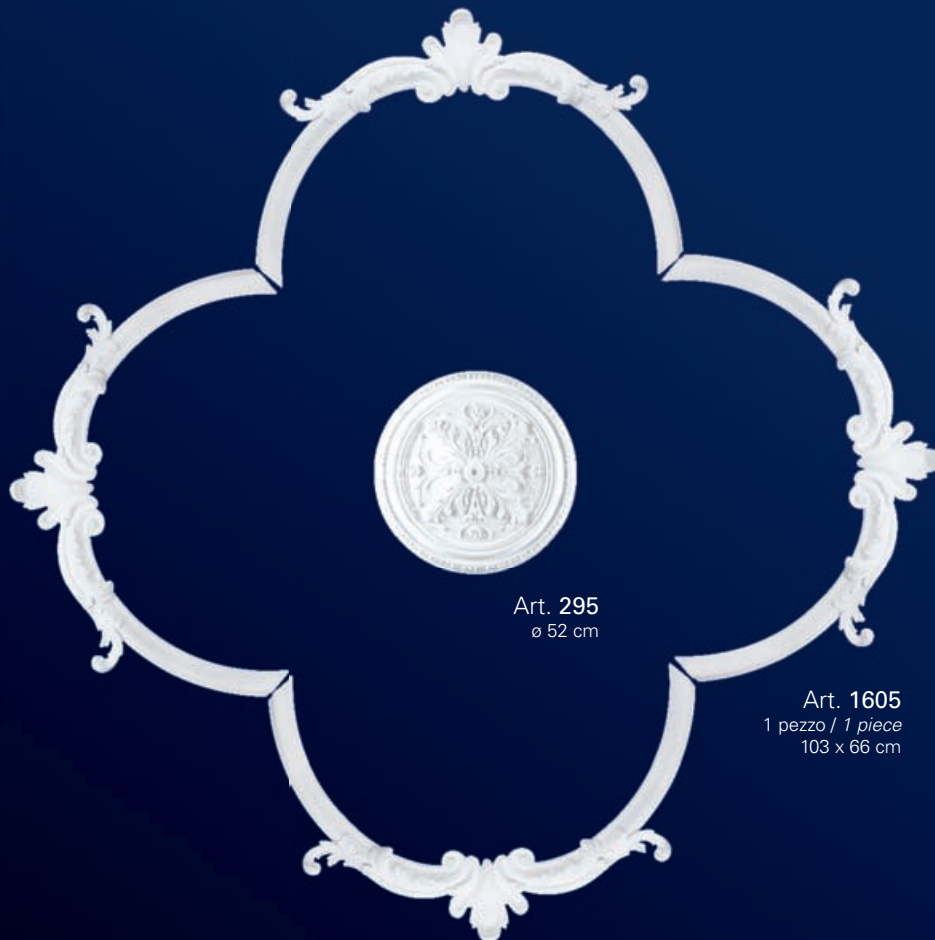
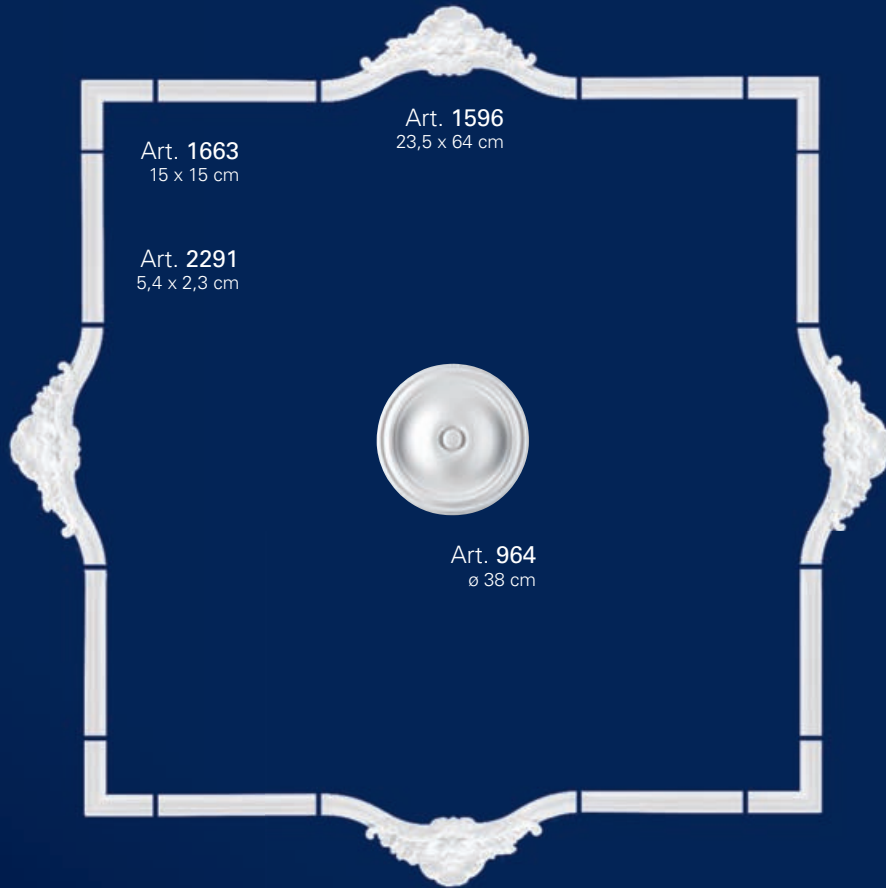

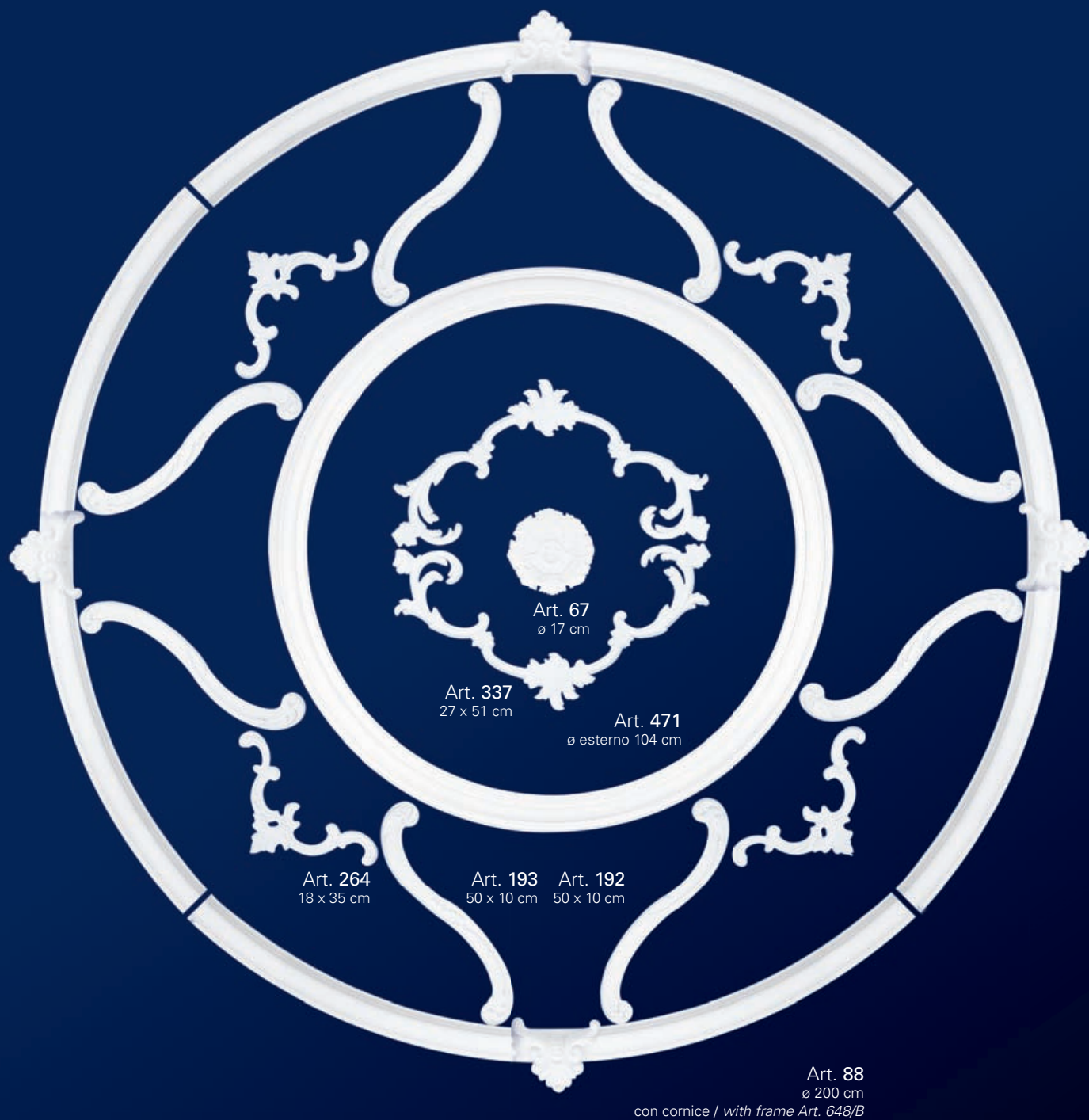

Art. 67
ø 17 cm

Art. 337
27 x 51 cm

Art. 471
ø esterno 104 cm

Art. 264
18 x 35 cm

Art. 193 Art. 192
50 x 10 cm 50 x 10 cm

Art. 88
ø 200 cm
con cornice / with frame Art. 648/B

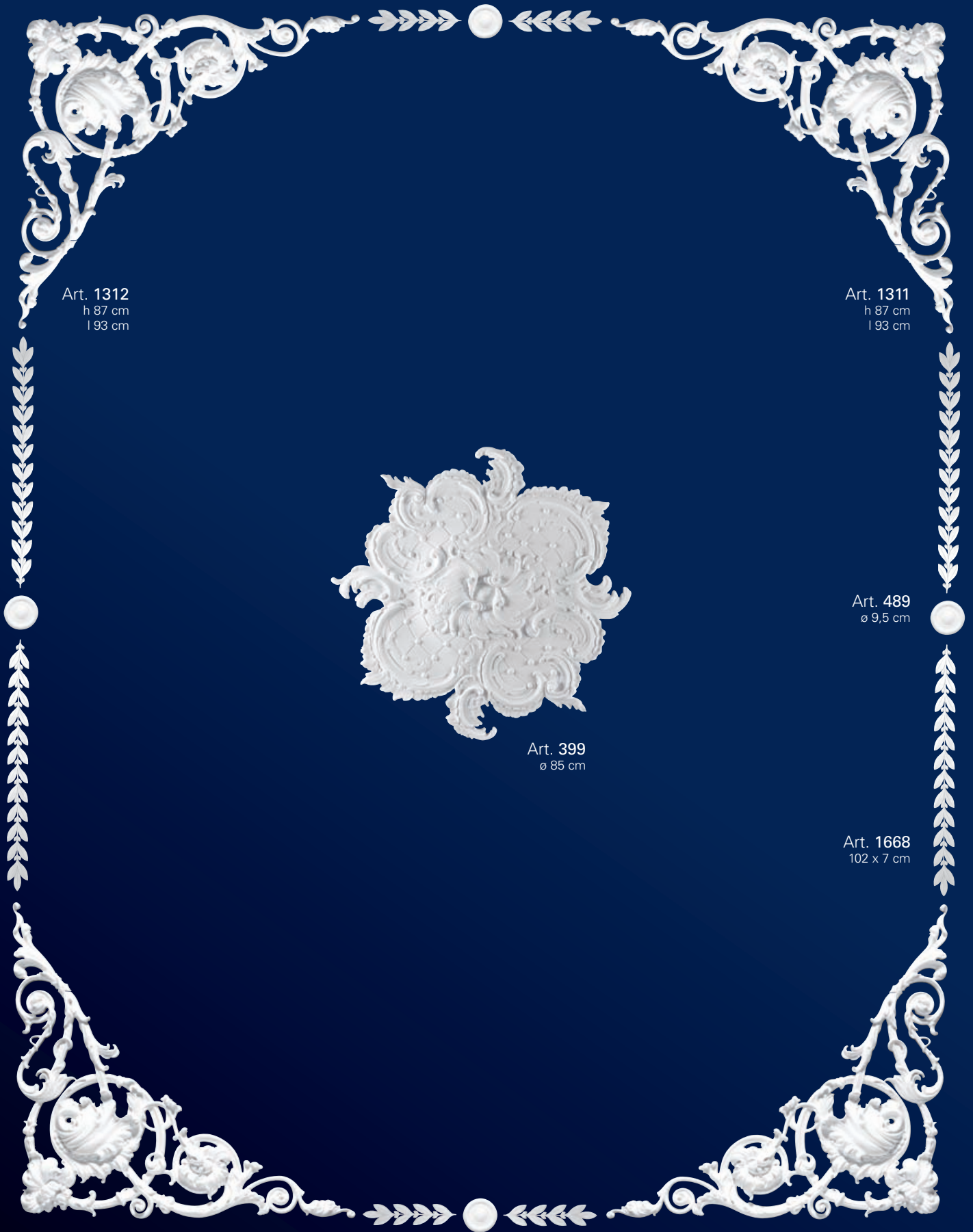

Art. 1312
h 87 cm
l 93 cm

Art. 1311
h 87 cm
l 93 cm

Art. 489
ø 9,5 cm

Art. 399
ø 85 cm

Art. 1668
102 x 7 cm

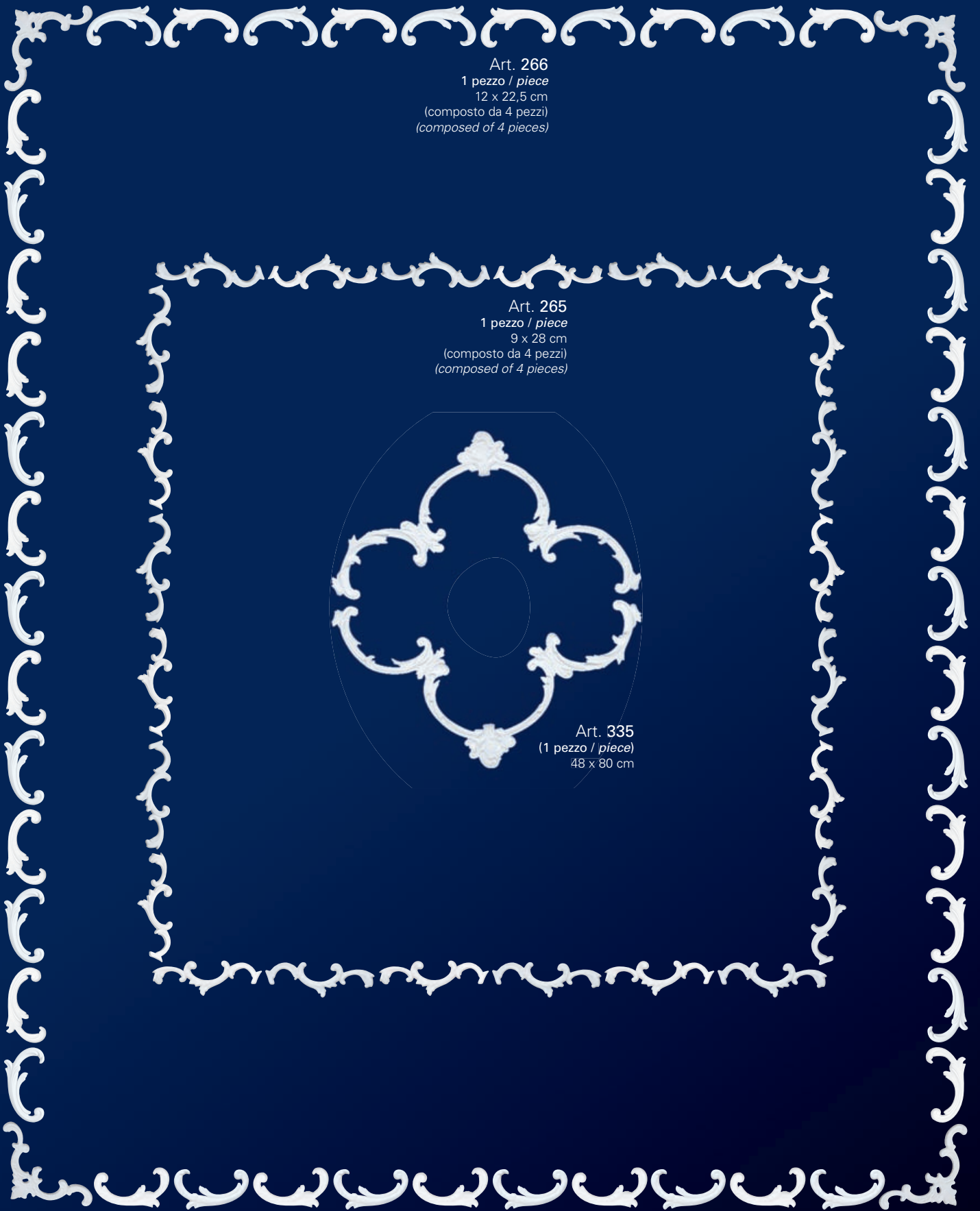

Art. 266
1 pezzo / piece
12 x 22,5 cm
(composto da 4 pezzi)
(composed of 4 pieces)

Art. 265
1 pezzo / piece
9 x 28 cm
(composto da 4 pezzi)
(composed of 4 pieces)



Art. 335
(1 pezzo / piece)
48 x 80 cm

Art. 264
1 pezzo / piece 18 x 35 cm
(composto da 4 pezzi)
(composed of 4 pieces)



Art. 396 - Grande / Large - \varnothing int. 45,9 cm
 \varnothing est. 51,5 cm

Art. 397 - Medio Grande / Medium Large - \varnothing int. 36,4 cm
 \varnothing est. 42 cm

Art. 398 - Medio / Medium - \varnothing int. 24,4 cm
 \varnothing est. 30 cm

Art. 951 - Piccolo / Small - \varnothing int. 14,4 cm
 \varnothing est. 20 cm
con cornice / with frame Art. 126

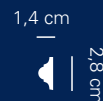

2,4 cm



Art. 471 - Grande / Large - \varnothing int. 90 cm - \varnothing est. 104 cm

Art. 472 - Medio / Medium - \varnothing int. 60 cm - \varnothing est. 74 cm

Art. 473 - Piccolo / Small - \varnothing int. 29 cm - \varnothing est. 43 cm
con cornice / with frame Art. 109



2,4 cm



Art. 1665 - \varnothing int. 36 cm
 \varnothing est. 50 cm
con cornice / with frame Art. 109



Art. 1499
 \varnothing int. 13,5 cm
 \varnothing est. 18 cm

Cerchi per faretto
Roundels for spotlights

2,4 cm



Art. 1667 - Grande / Large - \varnothing int. 76 cm - \varnothing est. 90 cm
Art. 1666 - Medio / Medium - \varnothing int. 51 cm - \varnothing est. 65 cm
Art. 1664 - Piccolo / Small - \varnothing int. 21 cm - \varnothing est. 35 cm
con cornice / with frame Art. 109



Art. 1383
 \varnothing int. 8,5 cm
 \varnothing est. 14 cm



Art. 1384
 \varnothing int. 5,5 cm
 \varnothing est. 11 cm

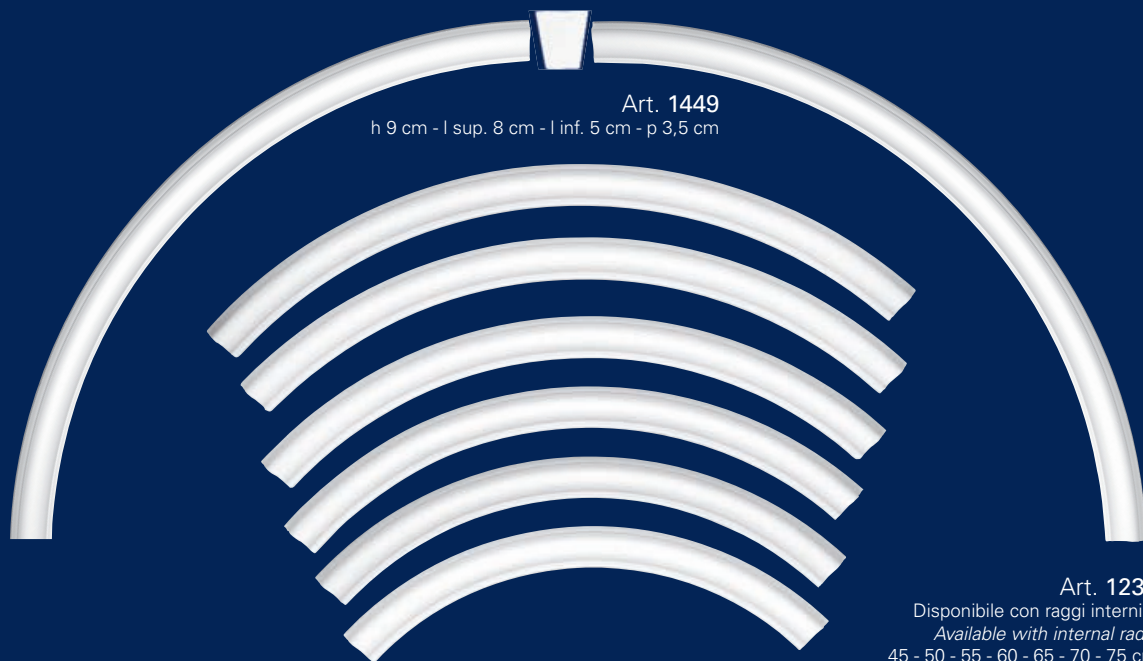

Art. 1449
h 9 cm - l sup. 8 cm - l inf. 5 cm - p 3,5 cm

2,4 cm

Art. 1235
Disponibile con raggi interni: /
Available with internal radii:
45 - 50 - 55 - 60 - 65 - 70 - 75 cm
con cornice / with frame Art. 648/B



6,4 cm

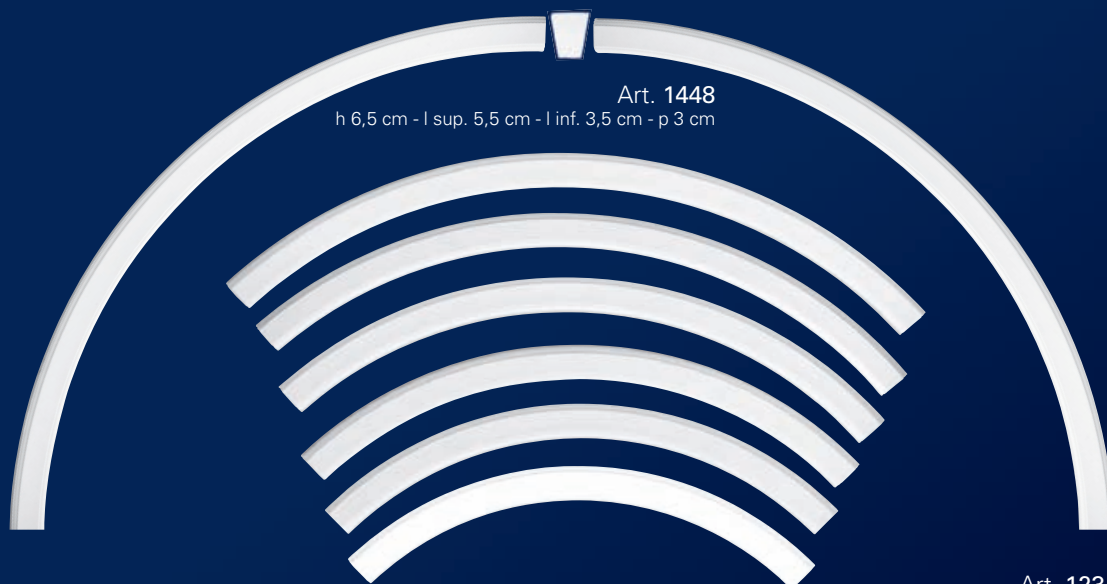

Art. 1448
h 6,5 cm - l sup. 5,5 cm - l inf. 3,5 cm - p 3 cm

1,4 cm

Art. 1234
Disponibile con raggi interni: /
Available with internal radii:
45 - 50 - 55 - 60 - 65 - 70 - 75 cm
con cornice / with frame Art. 2025



5,2 cm



Art. 1217/18 - ø int. 18 cm - ø est. 23,4 cm
Art. 1217/30 - ø int. 30 cm - ø est. 35,4 cm
Art. 1217/40 - ø int. 40 cm - ø est. 45,4 cm
Art. 1217/50 - ø int. 50 cm - ø est. 55,4 cm

Art. 1217/60 - ø int. 60 cm - ø est. 65,4 cm
Art. 1217/70 - ø int. 70 cm - ø est. 75,4 cm
Art. 1217/80 - ø int. 80 cm - ø est. 85,4 cm
Art. 1217/90 - ø int. 90 cm - ø est. 95,4 cm

Art. 1217/100 - ø int. 100 cm
ø est. 105,4 cm
con cornice / with frame Art. 2122

0,9 cm



2,7 cm

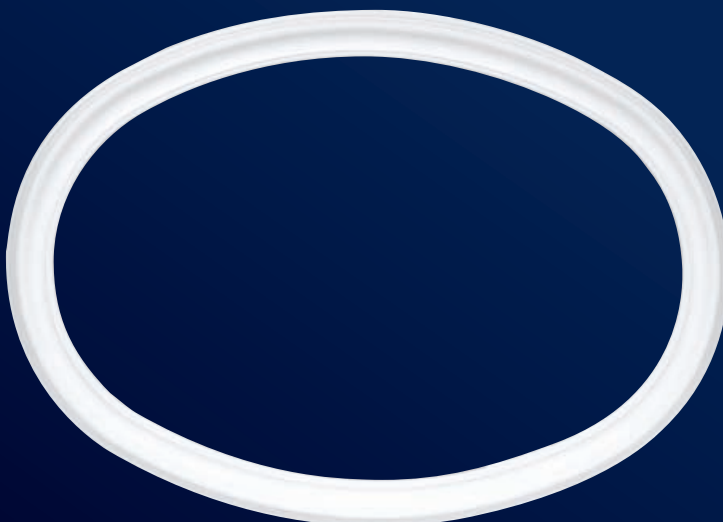
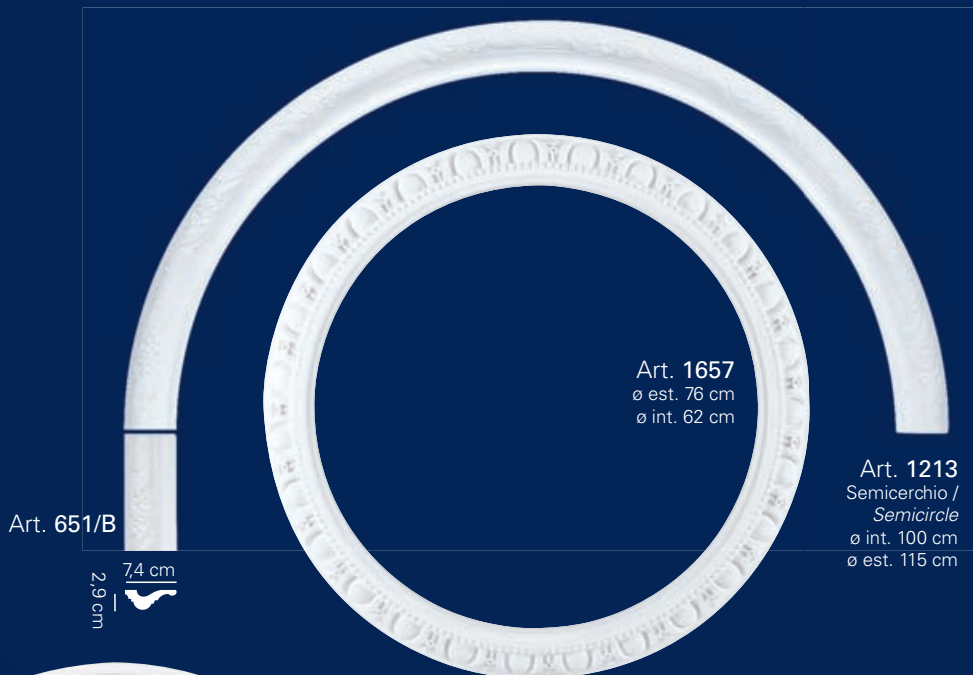



Art. 1534/S

Art. 1535
h 22 cm
l sup. 22 cm
l inf. 17 cm
p 10 cm

Art. 1534/D

48 cm

70 cm

Art. 2209

18,5 cm

9 cm

Art. 1258
h 18 cm
l sup. 18 cm
l inf. 12,5 cm
p 4 cm

Art. 17
Disponibile con raggi interni: /
Available with internal radii:
45 - 50 - 55 - 60 - 65 - 70 - 75 cm
con cornice / with frame Art. 925

15 cm

3,8 cm

Art. 925

Art. 1532
h 11 cm
l sup. 11,5 cm
l inf. 7 cm
p 10 cm

Art. 1533
h 10,5 cm
l 10,5 cm
p 10,5 cm

Art. 10
R int. 45 cm

7 cm

9 cm

Art. 936

Art. 1012
ø int. 90 cm
ø est. 100 cm

3,5 cm

2,3 cm

5 cm

5 cm

Art. 943

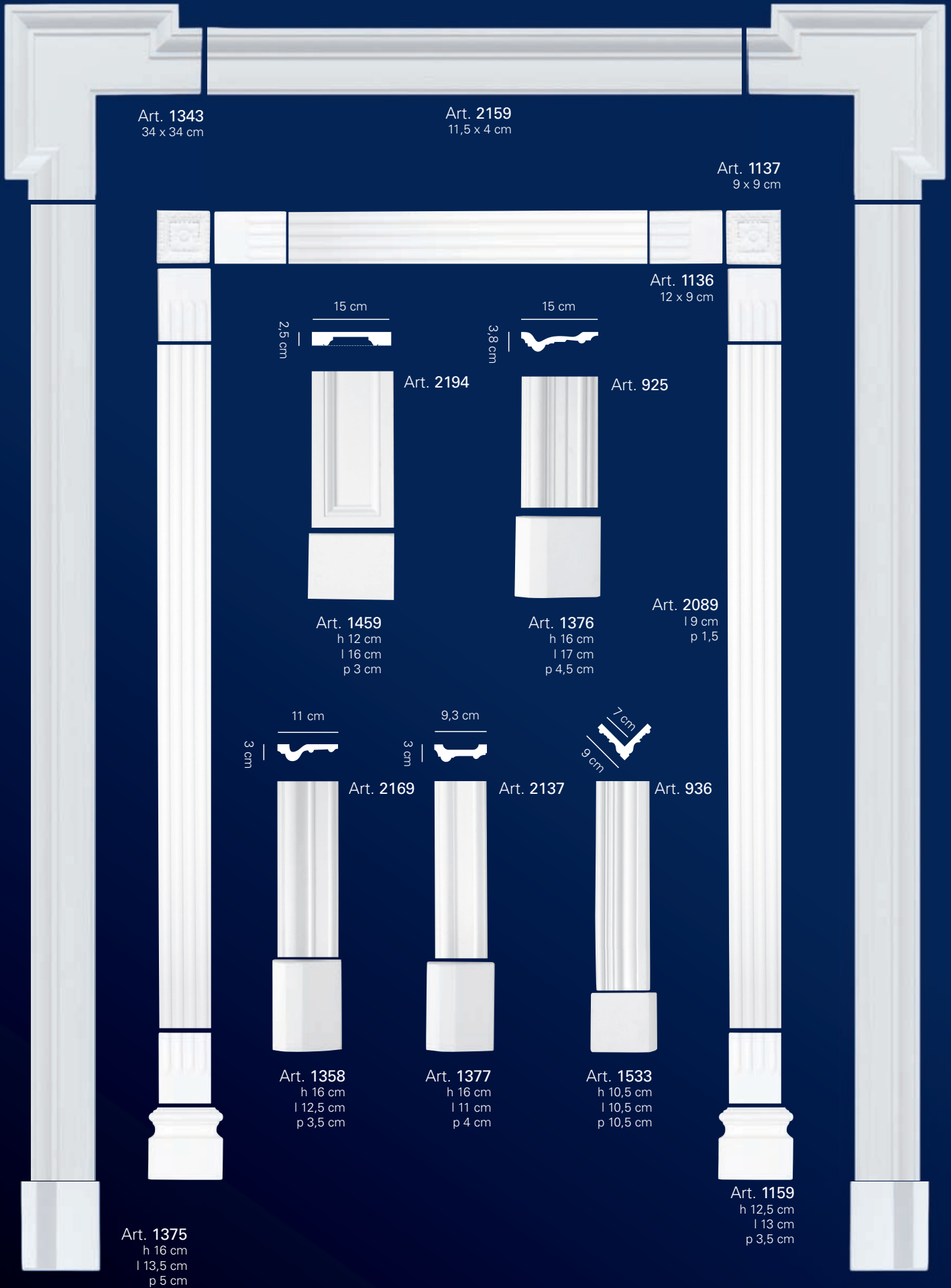

Art. 1343
34 x 34 cm

Art. 2159
11,5 x 4 cm

Art. 1137
9 x 9 cm

Art. 1136
12 x 9 cm

15 cm
2,5 cm

15 cm
3,8 cm

Art. 2194

Art. 925

Art. 1459
h 12 cm
l 16 cm
p 3 cm

Art. 1376
h 16 cm
l 17 cm
p 4,5 cm

Art. 2089
l 9 cm
p 1,5

11 cm
3 cm

9,3 cm
3 cm

7 cm
9 cm

Art. 2169

Art. 2137

Art. 936

Art. 1358
h 16 cm
l 12,5 cm
p 3,5 cm

Art. 1377
h 16 cm
l 11 cm
p 4 cm

Art. 1533
h 10,5 cm
l 10,5 cm
p 10,5 cm

Art. 1375
h 16 cm
l 13,5 cm
p 5 cm

Art. 1159
h 12,5 cm
l 13 cm
p 3,5 cm

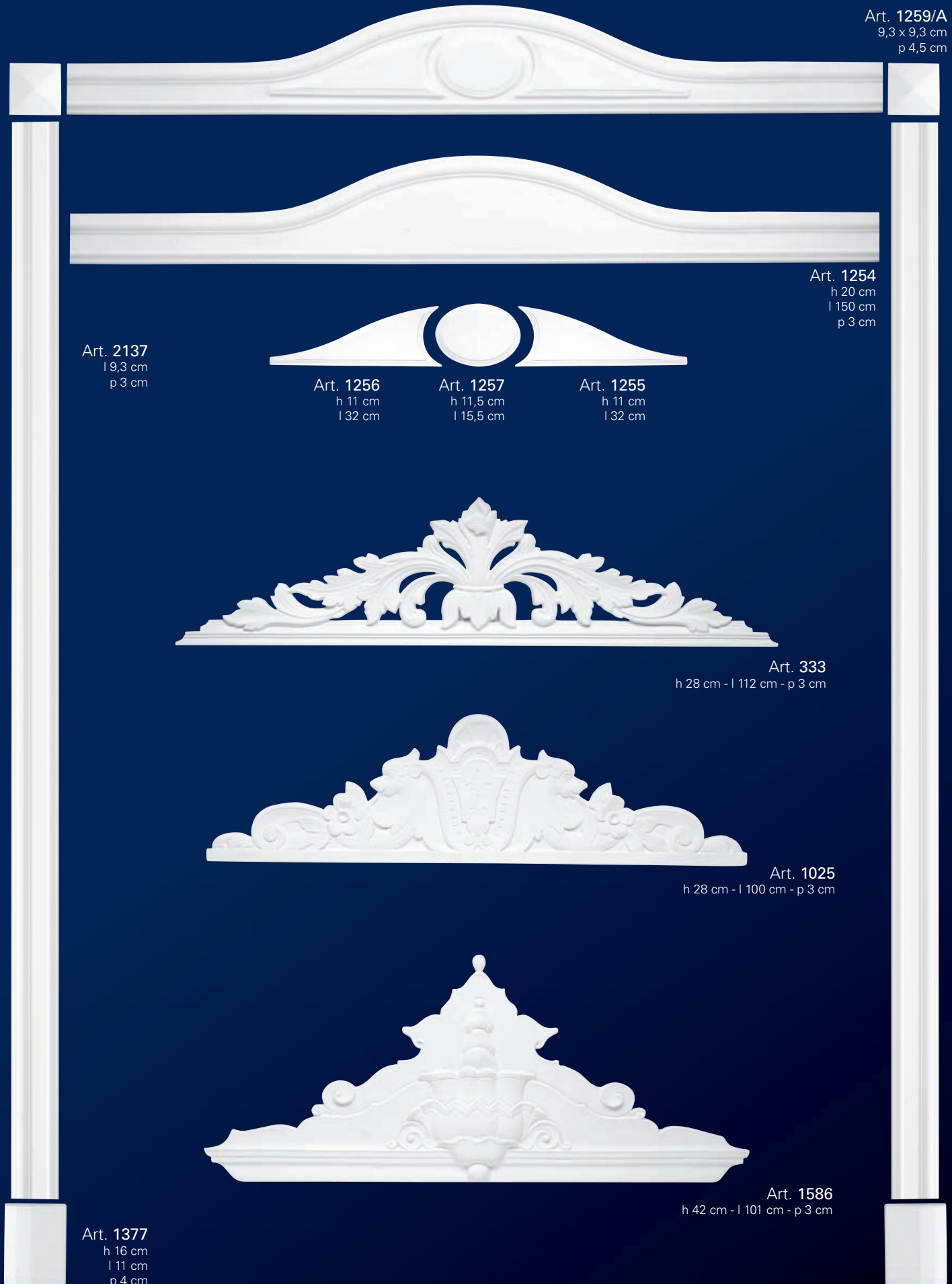

Art. 1259/A
9,3 x 9,3 cm
p 4,5 cm

Art. 1254
h 20 cm
l 150 cm
p 3 cm

Art. 2137
l 9,3 cm
p 3 cm

Art. 1256
h 11 cm
l 32 cm

Art. 1257
h 11,5 cm
l 15,5 cm

Art. 1255
h 11 cm
l 32 cm

Art. 333
h 28 cm - l 112 cm - p 3 cm

Art. 1025
h 28 cm - l 100 cm - p 3 cm

Art. 1586
h 42 cm - l 101 cm - p 3 cm

Art. 1377
h 16 cm
l 11 cm
p 4 cm



Art. 1660
39 x 189 cm



Art. 1176
h 45 cm - l 146 cm - p 5 cm



Art. 1171
h 42 cm - l 119,5 cm - p 9 cm



Art. 1658
h 68 cm
l 117 cm
p 3 cm



Art. 1357/S
19,5 cm

Art. 1357/D
19,5 cm

Art. 2128
h 11,2 cm - p 4,5



Art. 1360/S
19 cm

Art. 1360/D
19 cm

Art. 2169
h 11 cm - p 3 cm



Art. 1349/S
18 cm

Art. 1349/D
18 cm

Art. 2137
h 9,3 cm - p 3 cm



Art. 1347/S
16 cm

Art. 1347/D
16 cm

Art. 2163
h 6,5 cm - p 1,8 cm



Art. 1348/S
17,5 cm

Art. 1348/D
17,5 cm

Art. 648/B
h 6,4 cm - p 2,4 cm



Art. 1643/S
16,5 cm

Art. 1643/D
16,5 cm

Art. 612
h 5,4 cm - p 2 cm



Art. 1649/S
10 cm

Art. 1649/D
10 cm

Art. 180
h 4,5 cm - p 1,8 cm



Art. 1045/S
10,5 cm

Art. 1045/D
10,5 cm

Art. 128
h 3,6 cm - p 1,7 cm

Art. 1423
16 x 40 cm

Art. 1423
16 x 40 cm



Art. 1422
16 x 60 cm

Art. 1423
16 x 40 cm



Art. 1424
80 x 40 cm

Art. 1424
80 x 40 cm

Art. 1420
60 x 60 cm

Art. 1421
60 x 40 cm

Art. 2169
h 11 cm - p 3 cm

Art. 2086
4 x 1 cm

Art. 1360/S
19 cm



Art. 1360/D
19 cm



Art. 1381
60 x 40 cm

Art. 1380
60 x 60 cm

Art. 1381
60 x 40 cm



Art. 2093
16 x 2 cm

Art. 1347/S
16 cm

Art. 2163 h 6,5 cm - p 1,8 cm

Art. 1347/D
16 cm



Art. 1385
h 40 cm
l 14 cm

Art. 126
2,8 x 1,4 cm

Art. 398
ø est. 30 cm

Art.
2198
13 x 2 cm





Art. 2150
13,8 x 11,3 cm

Art. 1654
h 26 cm - l 55 cm - p 17 cm

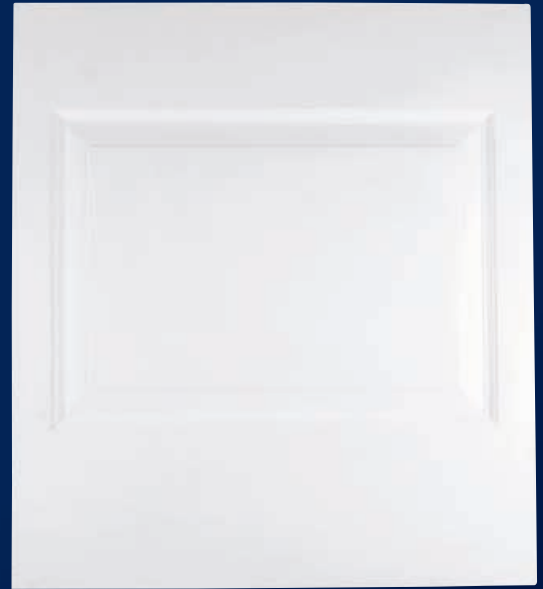
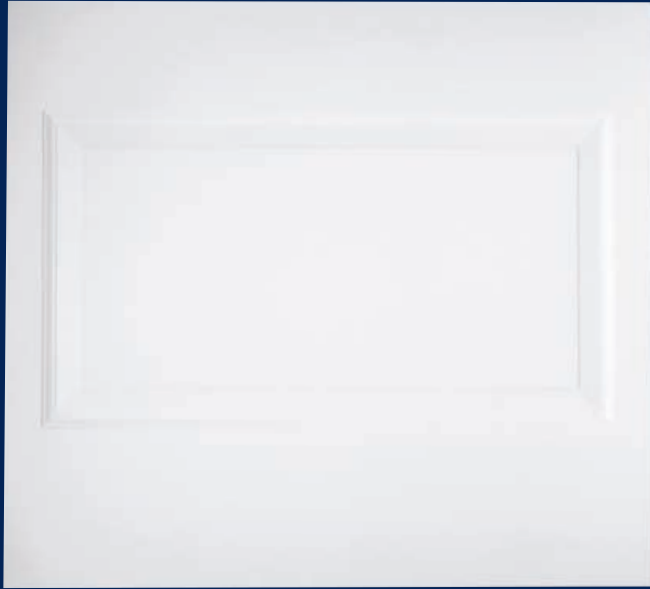

Art. 1566
h 92,5 cm
l 102 cm

Art. 1565
h 92,5 cm
l 82 cm



Art. 2213
h 172,5 cm
l 20 cm
p 3 cm

Art. 612
5,4 x 2 cm

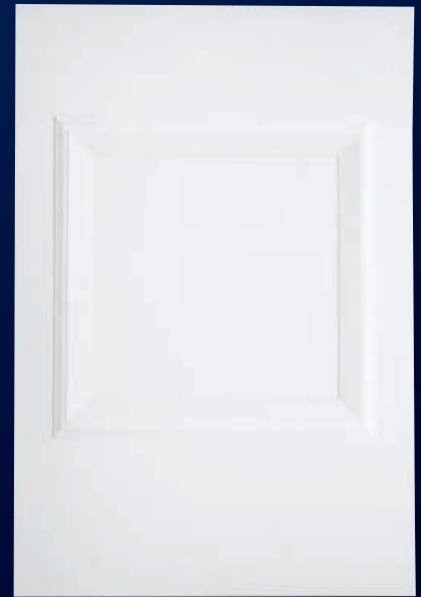

Art. 1562
h 92,5 cm
l 32 cm

Art. 1563
h 92,5 cm
l 42 cm

Art. 1561
h 92,5 cm
l est. 24 cm
l int. 20 cm
p 5 cm

Art. 1564
h 92,5 cm
l 62,5 cm



Art. 2198
13 x 2 cm

24 cm



Art. 1531
185 x 94 cm



Art. 1529
185 x 60 cm



Art. 1530
121 x 94 cm



Villa Privata - Yerevan (Armenia)
Private villa



Hotel Plaza - Pescara

Di seguito sono rappresentati alcuni esempi di utilizzo degli articoli di nostra produzione progettati in Auto Cad.

Questa simulazione serve per capire le potenzialità progettuali dei nostri manufatti e, avvalendosi dell'aiuto di tecnici del settore, e della propria fantasia e gusto, è possibile avere una visione d'insieme di più articoli assemblati a seconda dell'ambiente a cui sono destinati. Tale effetto ne esalta il risultato finale, rispetto al singolo prodotto rappresentato nel catalogo, ed esprime ancor più le potenzialità applicative dei nostri prodotti.

The examples below show CAD application simulations for the several of the articles we produce.

The CAD tool can aid in understanding the design potential of our products by providing a platform on which sector technicians' know-how interacts with one's own imaginativeness and taste to generate views of articles assembled in the spaces for which they are selected. By placing the accent on the overall result rather than the single products as represented in the catalogue, the CAD simulations express the true application potential of our products.

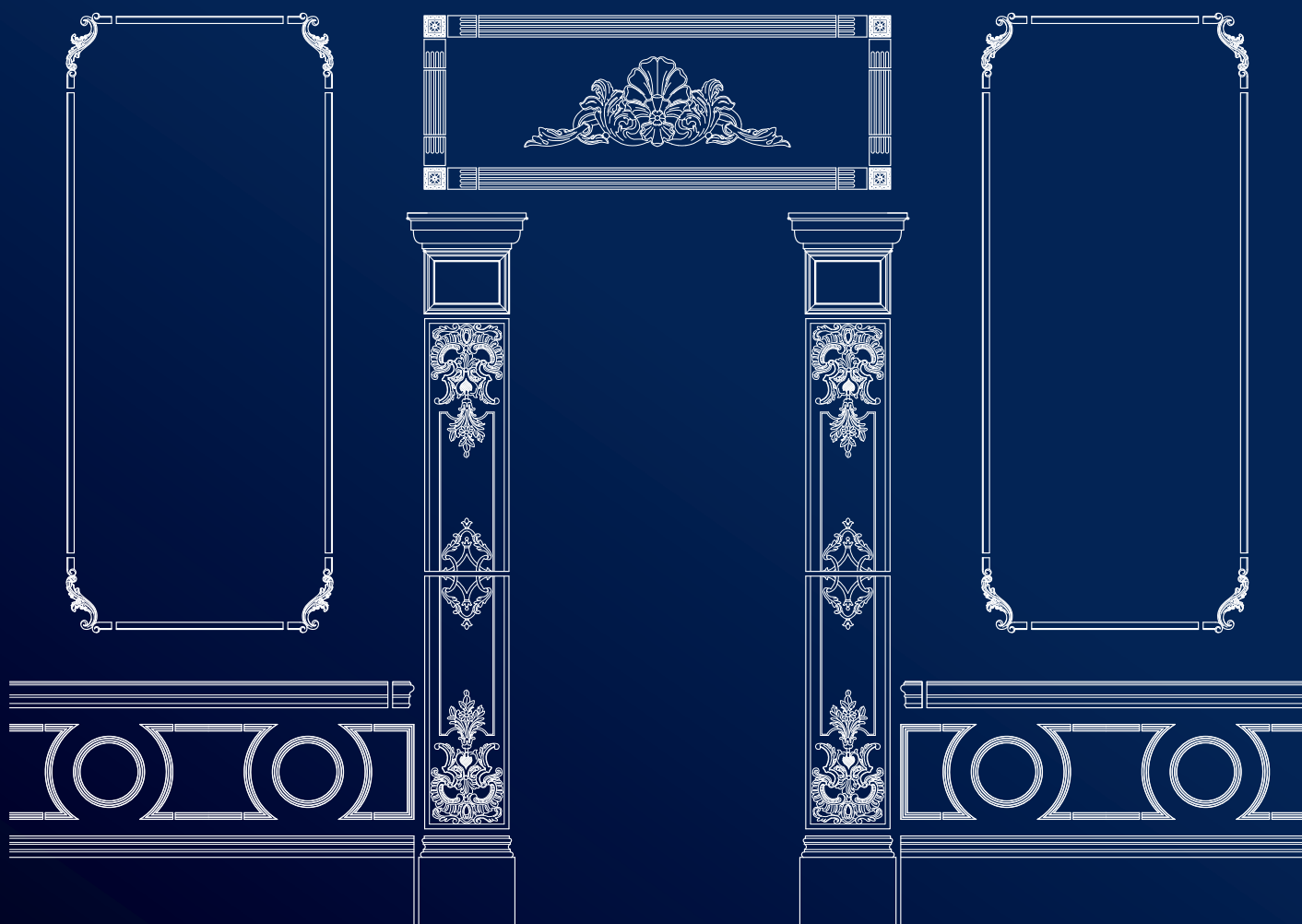

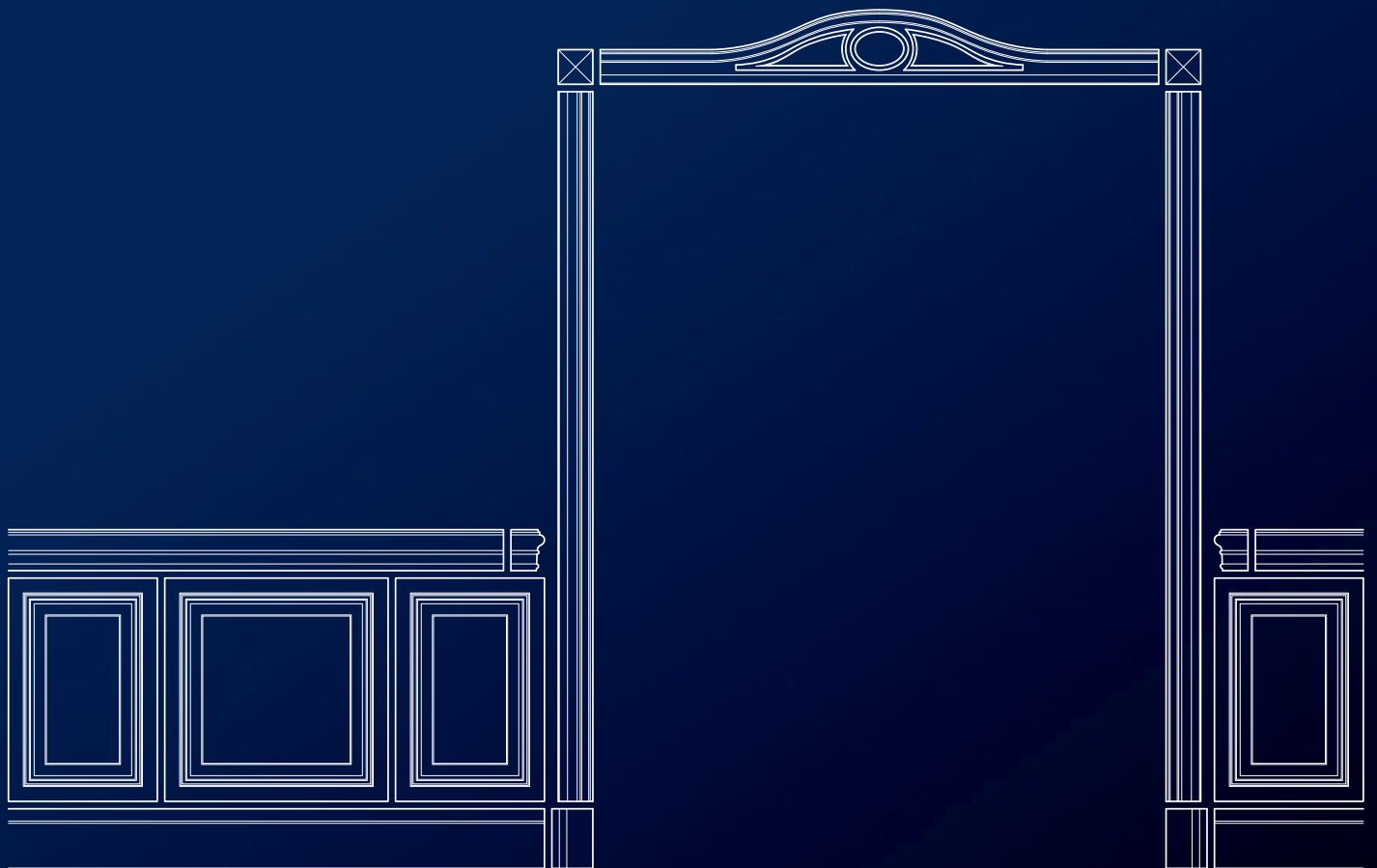
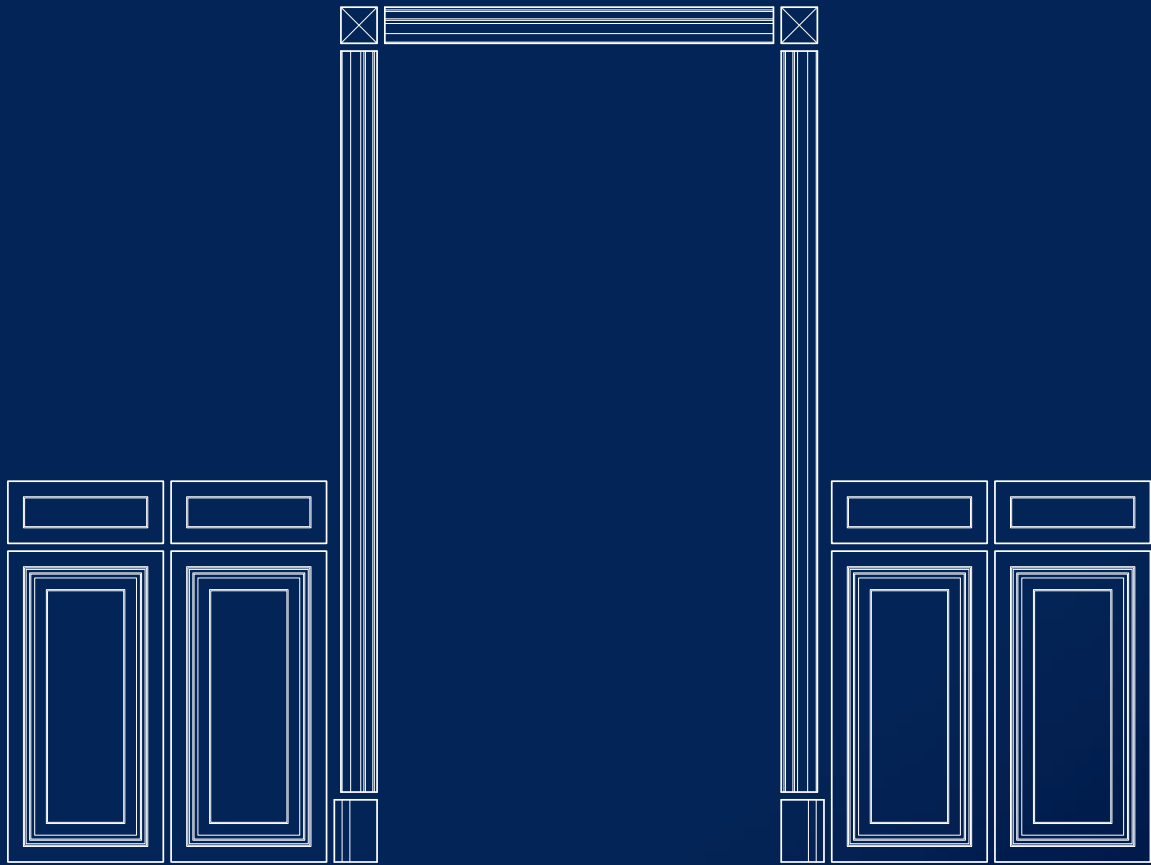



La chiave di lettura ideale è quella di pensare i manufatti della linea esterno, anche in modo indipendente dalla suddivisione indicata nel catalogo; le soluzioni adottate in fase di progettazione e realizzazione lasciano ampio spazio all'iniziativa dei tecnici utilizzatori per le combinazioni più diverse. A tale scopo è stato realizzato un cd-rom, con la possibilità di scaricare i file degli articoli in formato DWG e utilizzabili con i più diffusi software di CAD (Computer Aided Design). Il materiale di produzione è un'esclusiva formula di malta cementizia alternata ad articoli realizzati con gessi speciali idrorepellenti. Questi ultimi sono particolarmente adatti ad ambienti umidi, garantendo comunque una elevata resistenza nel tempo anche se montati all'esterno, purchè al riparo dall'attacco diretto degli agenti atmo-sferici più aggressivi come ad esempio la pioggia battente.

La facilità di montaggio ed un peso inferiore, rispetto ad oggetti con le stesse caratteristiche realizzati in cemento tradizionale, si aggiungono ai vantaggi di questi materiali che risultano ideali per qualsiasi realizzazione e ristrutturazione di esterni.

The ideal perspective on the Exteriors Line abolishes all the borders between the catalogue groupings and instead focuses on solutions, leaving ample space for user/technicians to mix and match and express their design sense in infinite combinations. With this in mind, we have prepared a CD-ROM and offer the possibility of downloading the catalogue files in DWG format for use with the most common Computer Aided Design (CAD) software. Our primary materials are an exclusive cement mortar formula and special water-repellent plasters. Products in the latter material are especially suited for application in damp environments, since they guarantee high resistance and long life in nearly all situations, even if installed outdoors-so long as they are protected from direct aggression by such atmospheric agents as heavy rain.

Easy installation and light weight with respect to similar articles in traditional concrete are further advantages offered by these materials, which are thus ideal for any exterior construction or restructuring /restoration project.



1

1 - 2 - 3 Hotel Four Seasons - Firenze
Hotel Four Seasons - Florence

3



2





Abitazione privata - Viareggio (LU)
Private home





Abitazione Maurizio Fiori - Certaldo (FI)
Maurizio Fiori's house - Certaldo (FI)





Abitazione privata Yerevan - Armenia
Lavori eseguiti dalla società Trifina srl e progettati dall'architetto Giorgio Baldantoni.
*Private home Yerevan - Armenia
Work by Trifina srl to designs by Architect Giorgio Baldantoni.*





Hotel Concorde - Sant'Egidio alla Vibrata (TE)



1 - 2 Abitazione privata Cerreto Guidi (FI)
Private home

1

2





Villa Liberty - Lucca



Abitazione privata - Viareggio (LU)
Private home

Uffici del Governo - Malabo (Guinea Equatoriale)
Guinea Government Offices - Malabo (Equatorial Guinea)





Villa privata - Rossano (CS)
Assistenza e fornitura società F.M. Centro Colori Corigliano Scalo (CS).
Private villa - Rossano (CS)
Assistance and supply by F.M. Centro Colori - Corigliano Scalo (CS).



Linea
Esterno

Outdoor Line

Battistero

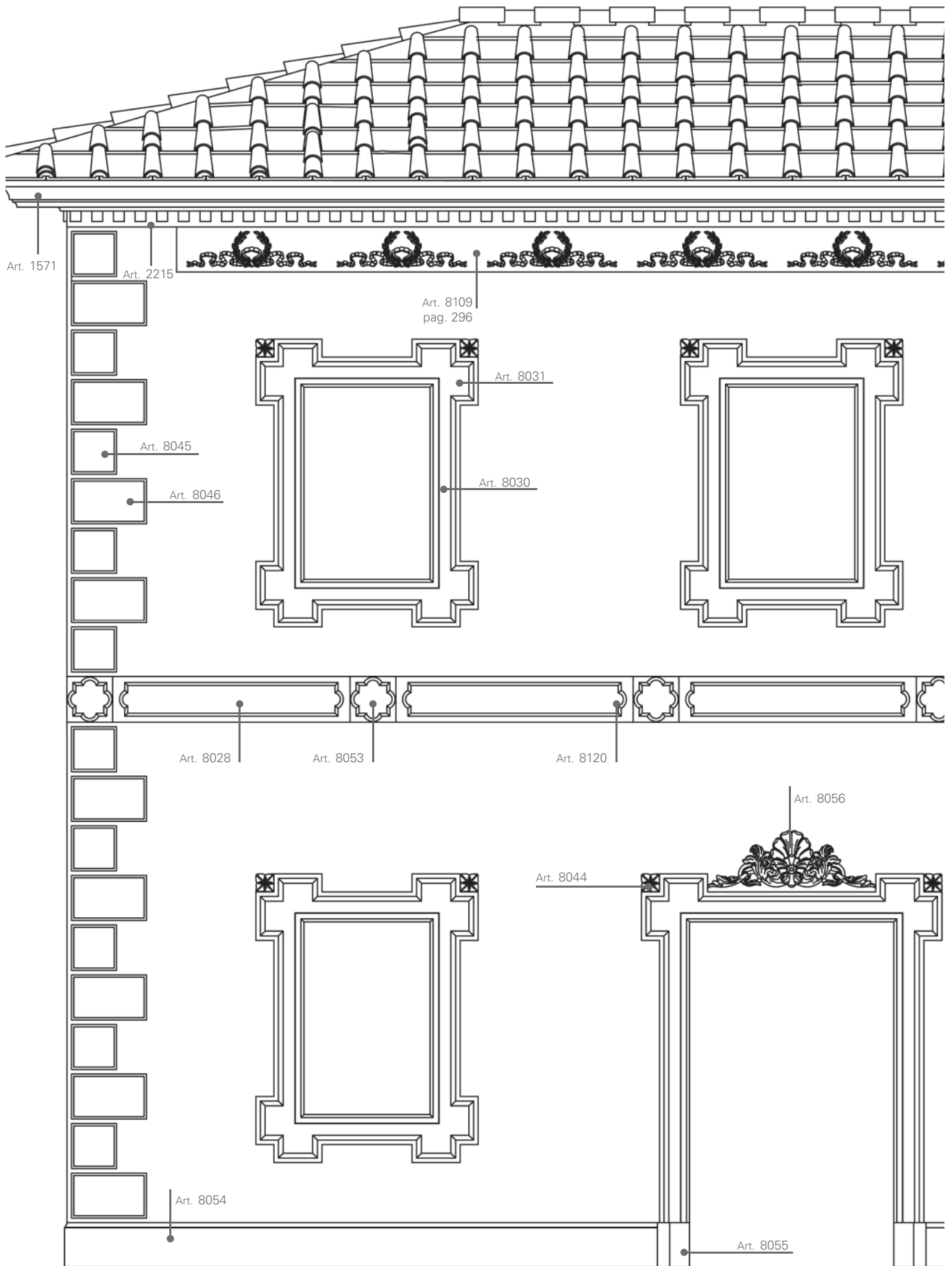

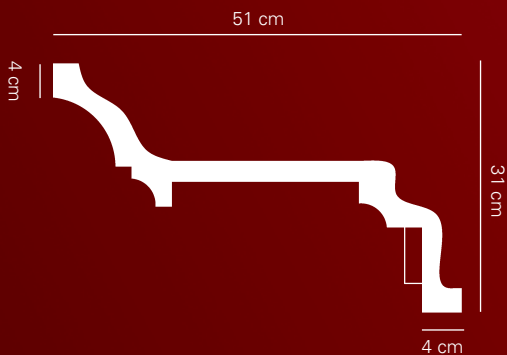

Art. 2215
Cornice sottogronda realizzata in gesso idrorepellente
Eave frame realized in water-repellent plaster



Art. 2244
Inseribile nella cornice / Can be added to the frame art. 2215
Realizzata in gesso idrorepellente / Realized in water-repellent plaster



Art. 2215
Realizzata in gesso idrorepellente / Realized in water-repellent plaster



Art. 8030

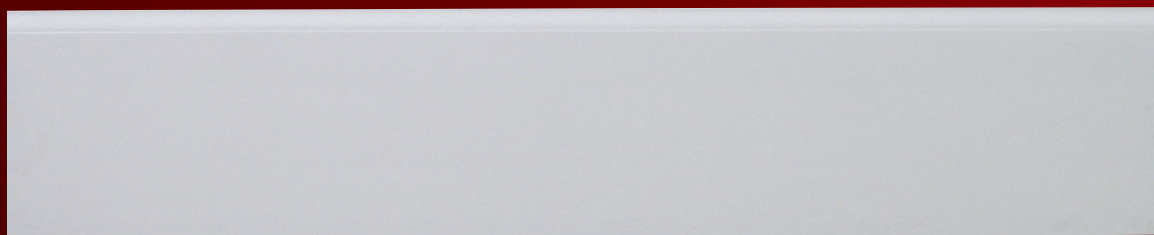

Art. 8054



Art. 8028



Art. 1571
Sezione con / Section with art. 2215
Realizzato in gesso idrorepellente
Realized in water-repellent plaster



Art. 8120
Terminale per cornice Art. 8028
Terminal for frame Art. 8028



Art. 8056



Art. 8053

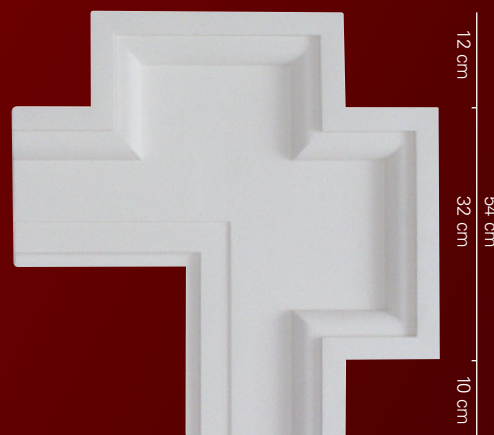

Art. 8031
Sezione con / Section with art. 8030



Art. 8045

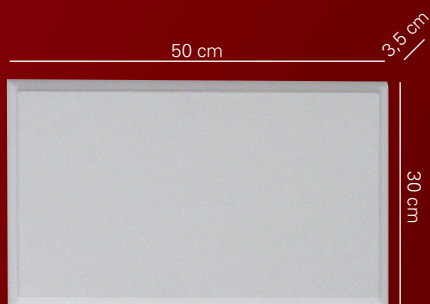

Art. 8046



Art. 8044

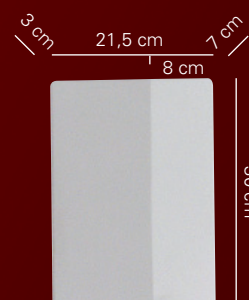

Art. 8055
Zoccolo di base per / Base for art. 8030

Linea
Esterno

Outdoor Line

Acanthocardia

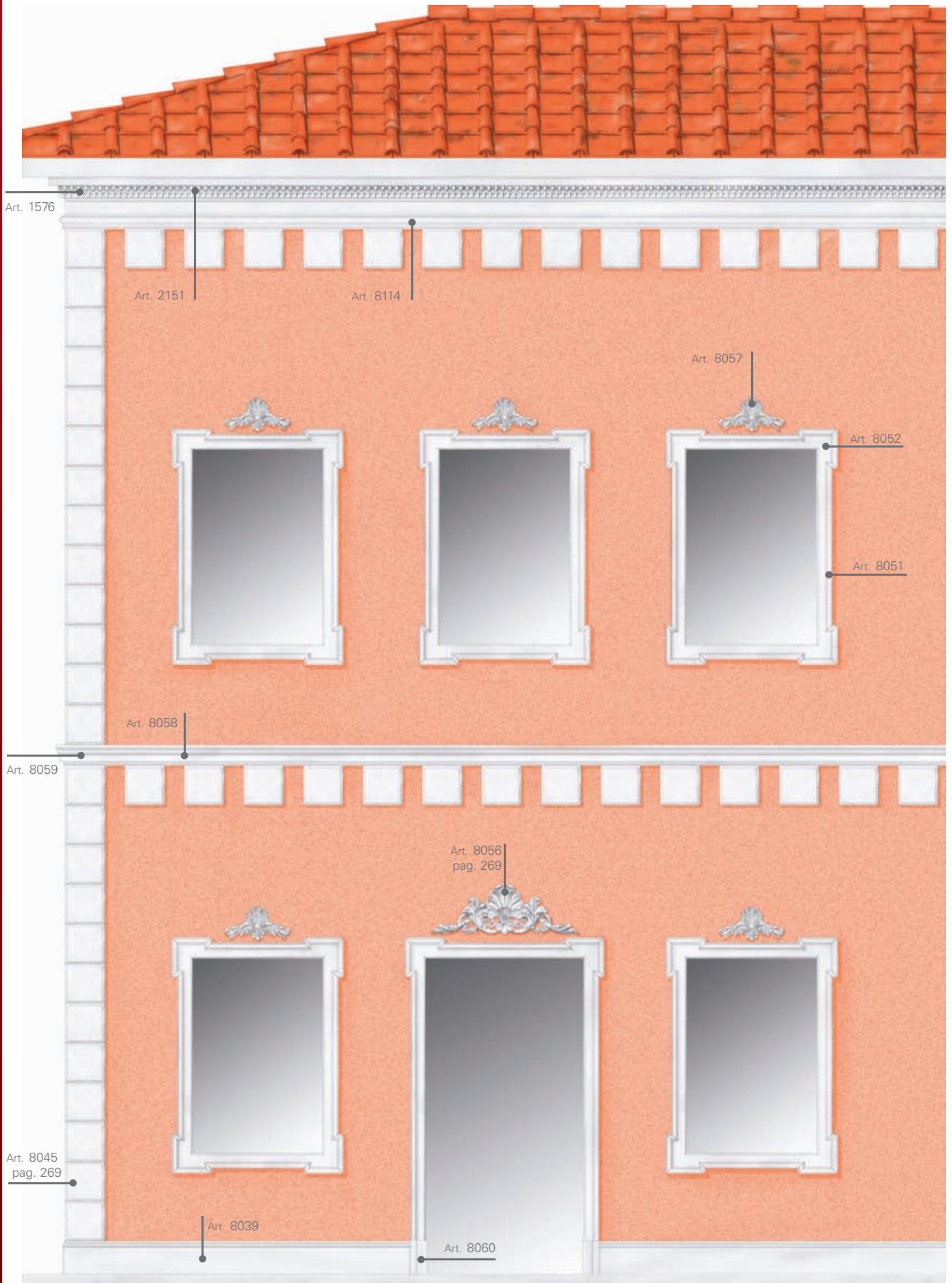

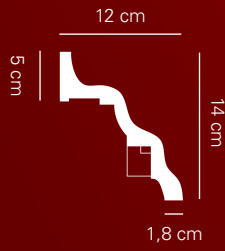

Art. 2151
Cornice sottogronda realizzata in gesso idrorepellente
Eave frame realized in water-repellent plaster



Art. 8058



Art. 8114



Art. 8051

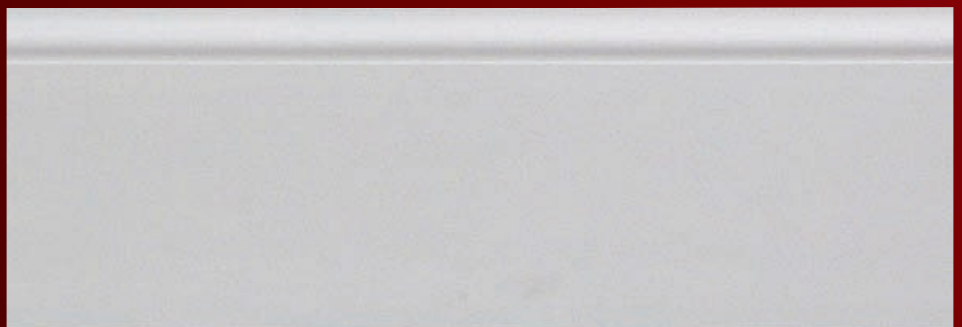

Art. 8039

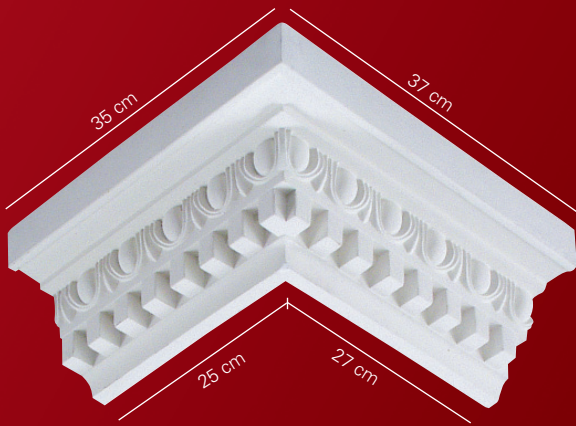

Art. 1576
Sezione con / Section with art. 2151
Realizzato in gesso idrorepellente
Realized in water-repellent plaster

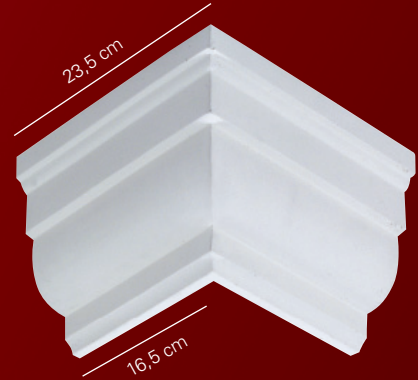

Art. 8059
Sezione con / Section with art. 8058



Art. 8057

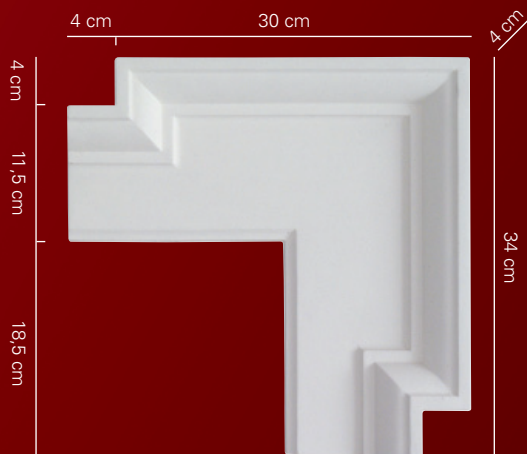

Art. 8052
Sezione con / Section with art. 8051

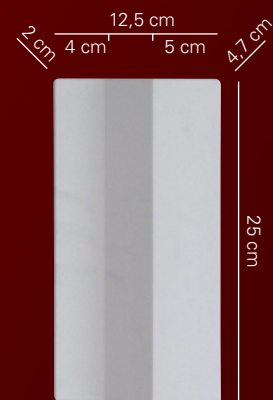

Art. 8060
Zoccolo di base per/
Base for art. 8051

Linea
Esterno

Outdoor Line

Agorà

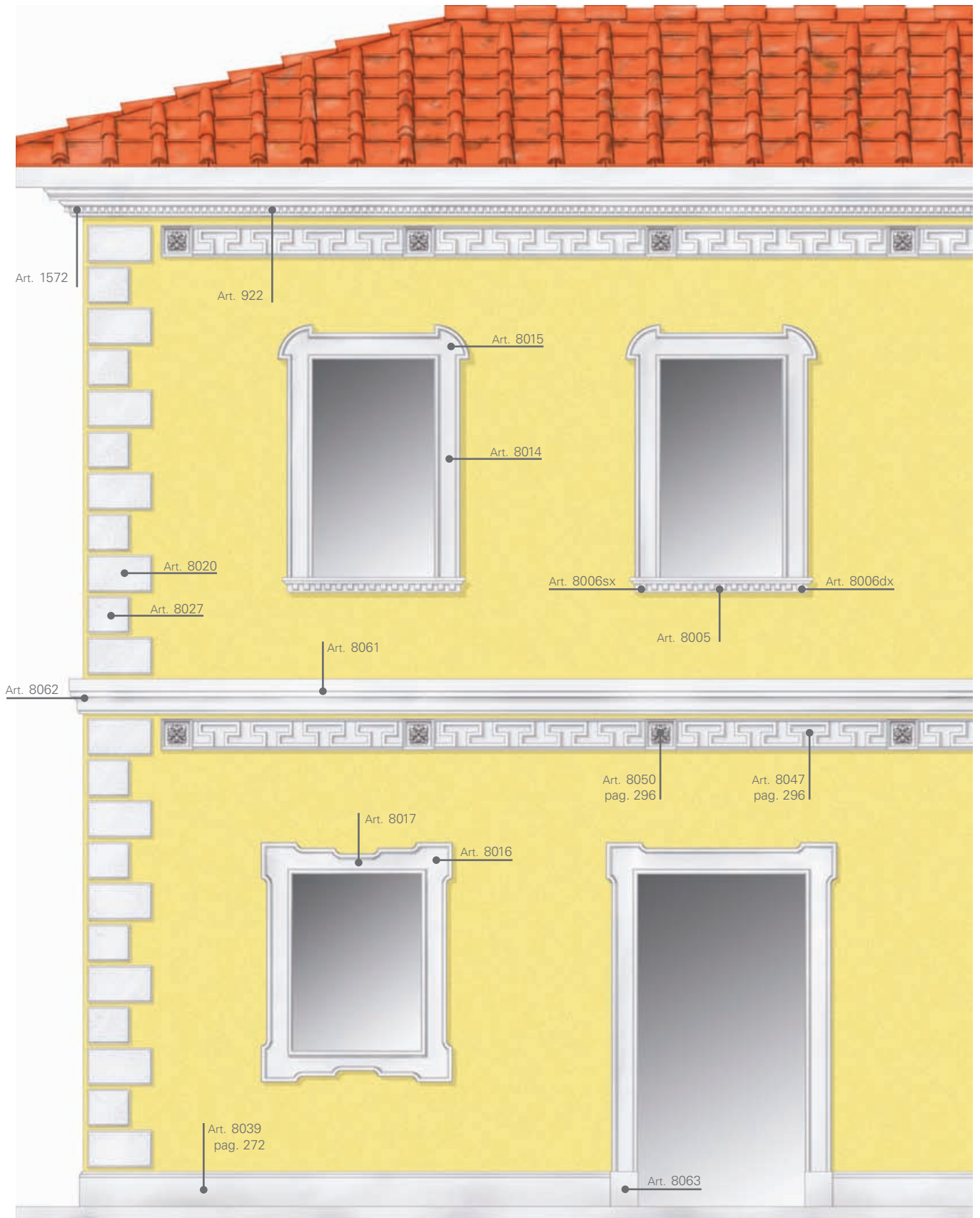

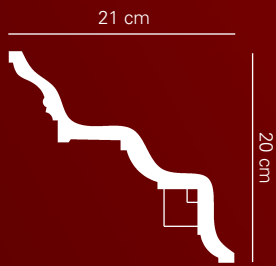

Art. 922
Cornice sottogronda realizzata in gesso idrorepellente
Eave frame realized in water-repellent plaster

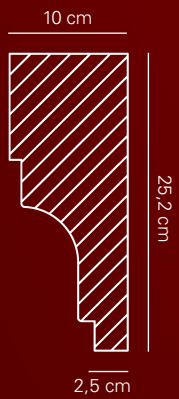

Art. 8061



Art. 8005

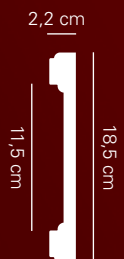

Art. 8014



Art. 8017
Sezione con / Section with art. 8014



Art. 1572

Sezione con / Section with art. 922
Realizzato in gesso idrorepellente
Realized in water-repellent plaster

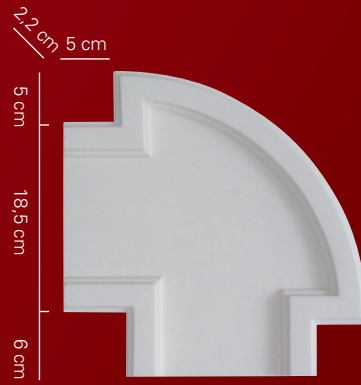

Art. 8015

Sezione con / Section with art. 8014

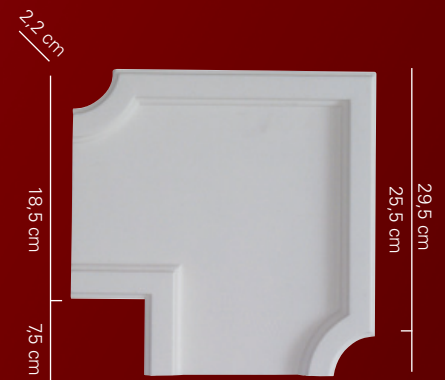

Art. 8016

Sezione con / Section with art. 8014

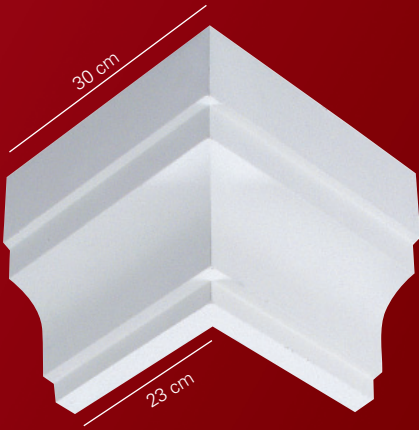

Art. 8062

Sezione con /
Section with art. 8061

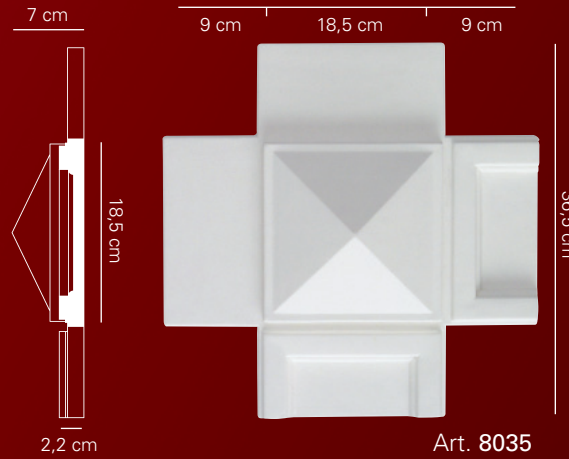

Art. 8035

Sezione con / Section with art. 8014



Art. 8006 sx

Art. 8006 dx

Sezione con / Section with art. 8005



Art. 8063

Zoccolo di base per /
Base for art. 8014



Art. 8020

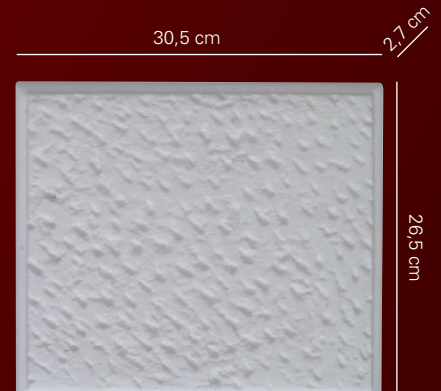

Art. 8027

Linea
Esterno

Outdoor Line



Archimede

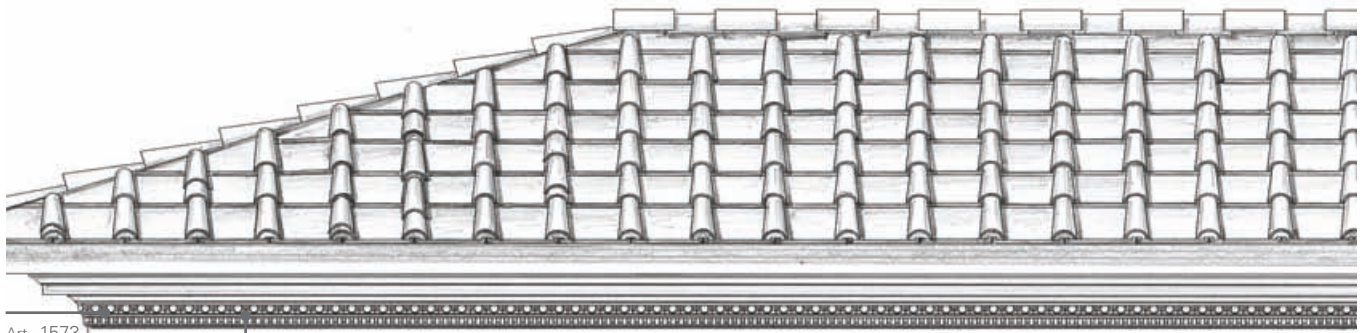

Art. 1573

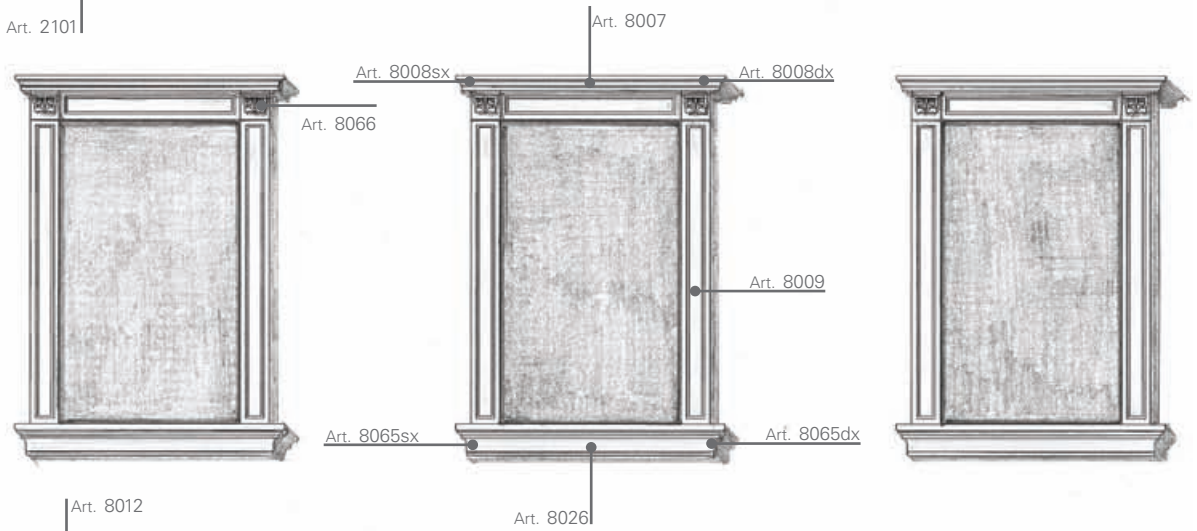

Art. 8064

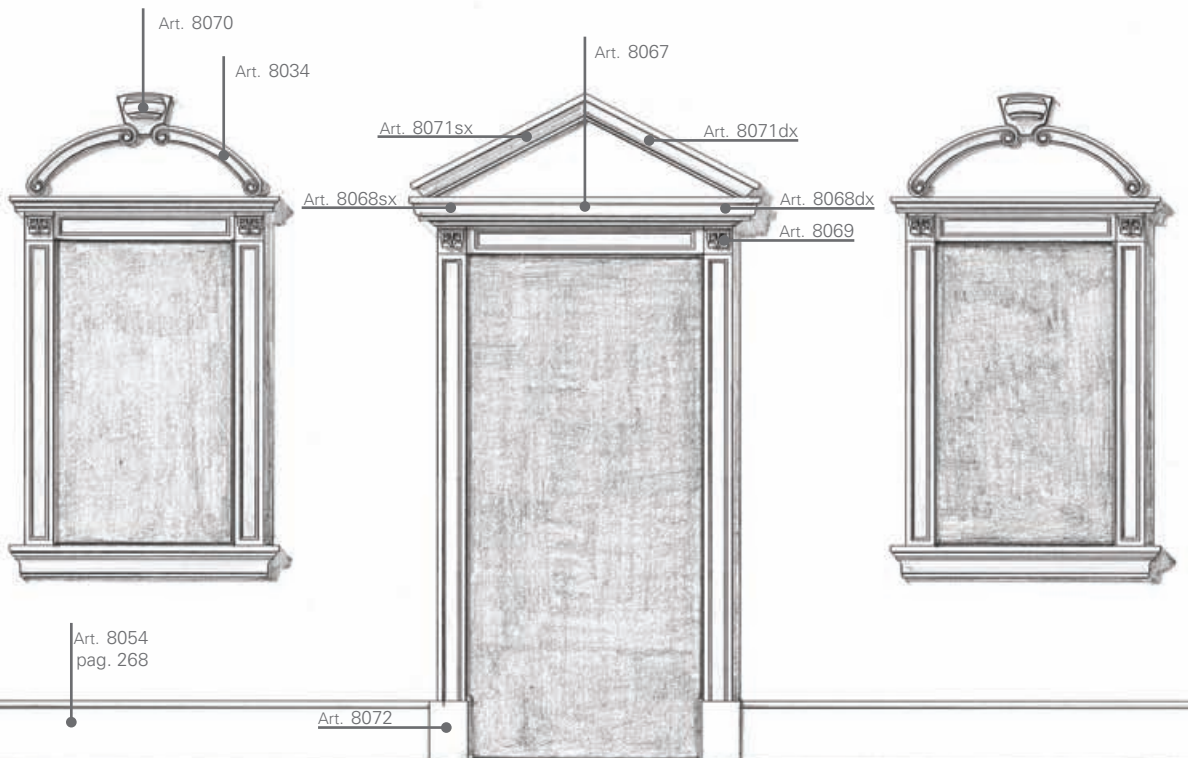

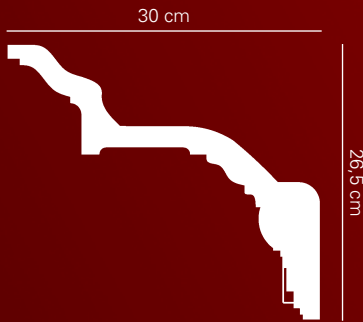

Art. 2101

Cornice sottogronda realizzata in gesso idrorepellente
Eave frame realized in water-repellent plaster

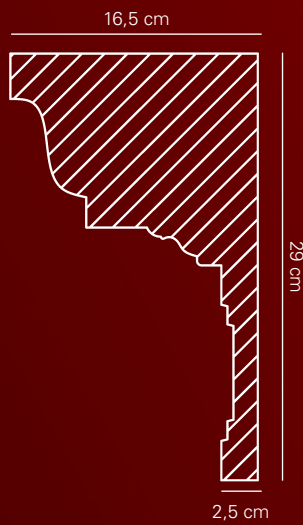

Art. 8067

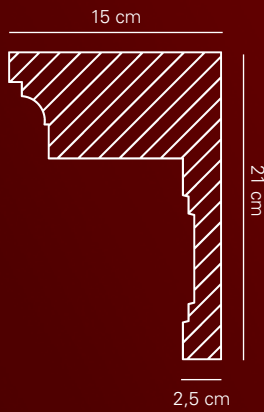

Art. 8007



Art. 8012



Art. 1573
Sezione con / Section with art. 2101
Realizzato in gesso idrorepellente
Realized in water-repellent plaster



Art. 8064
Sezione con / Section with art. 8012

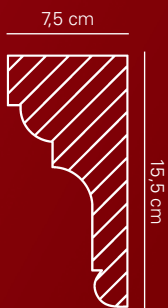

Art. 8026

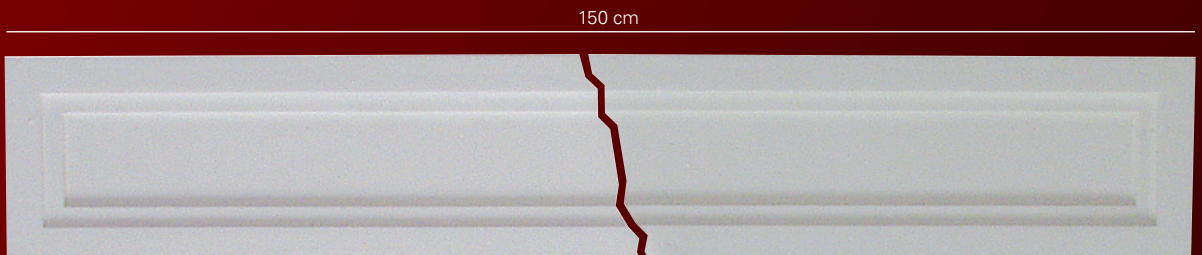

Art. 8009

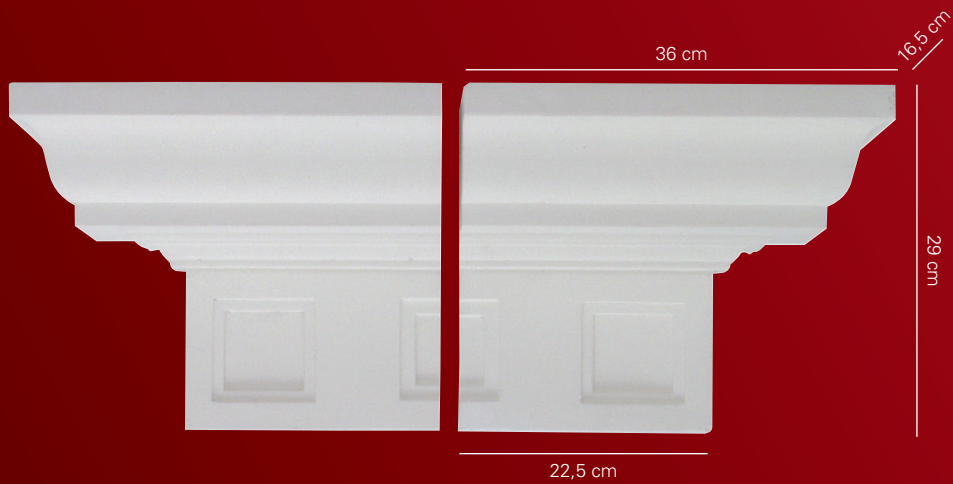

Art. 8068 sx

Art. 8068 dx
Sezione con / Section with art. 8067



Art. 8008 sx

Art. 8008 dx
Sezione con / Section with art. 8007

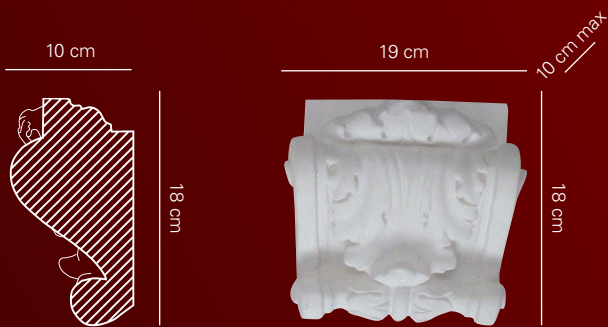

Art. 8069
Mensola inseribile in /
Shelf can be added
to art. 8068 dx/sx

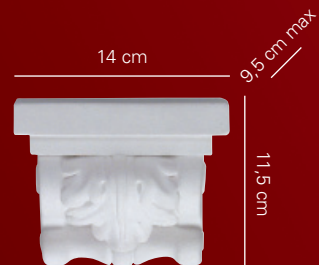

Art. 8066
Mensola inseribile in /
Shelf can be added
to art. 8008 dx/sx

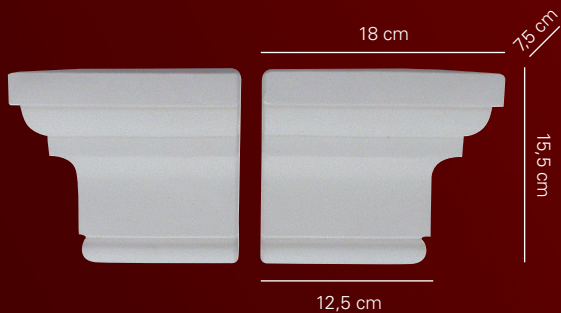

Art. 8065 sx

Art. 8065 dx
Sezione con /
Section with art. 8026



Art. 8082
Sezione con /
Section with art. 8026

Art. 8087
Sezione con /
Section with art. 8026

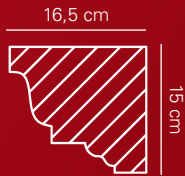

Art. 8071 sx - dx
Sezione
con parte superiore/
Section view
upper portion of Art. 8067

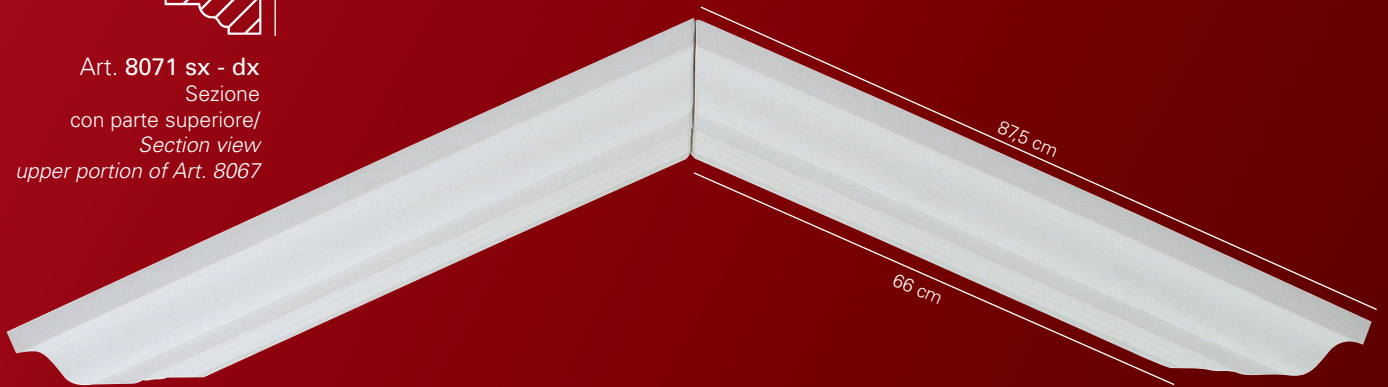

Art. 8071 sx

Art. 8071 dx



Art. 8013 sx

Art. 8013 dx
Sezione con / Section with art. 8012

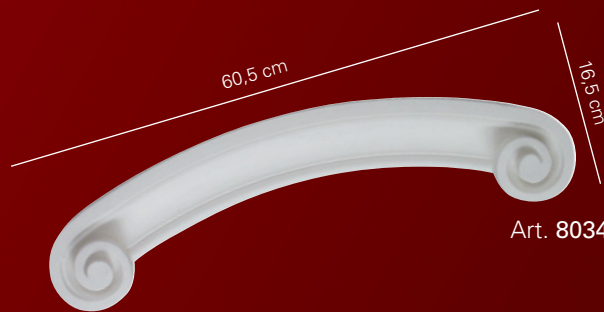

Art. 8034



Art. 8072
Zoccolo di base per/
Base for art. 8009



Art. 8070

Linea
Esterno

Outdoor Line

Bolgheri

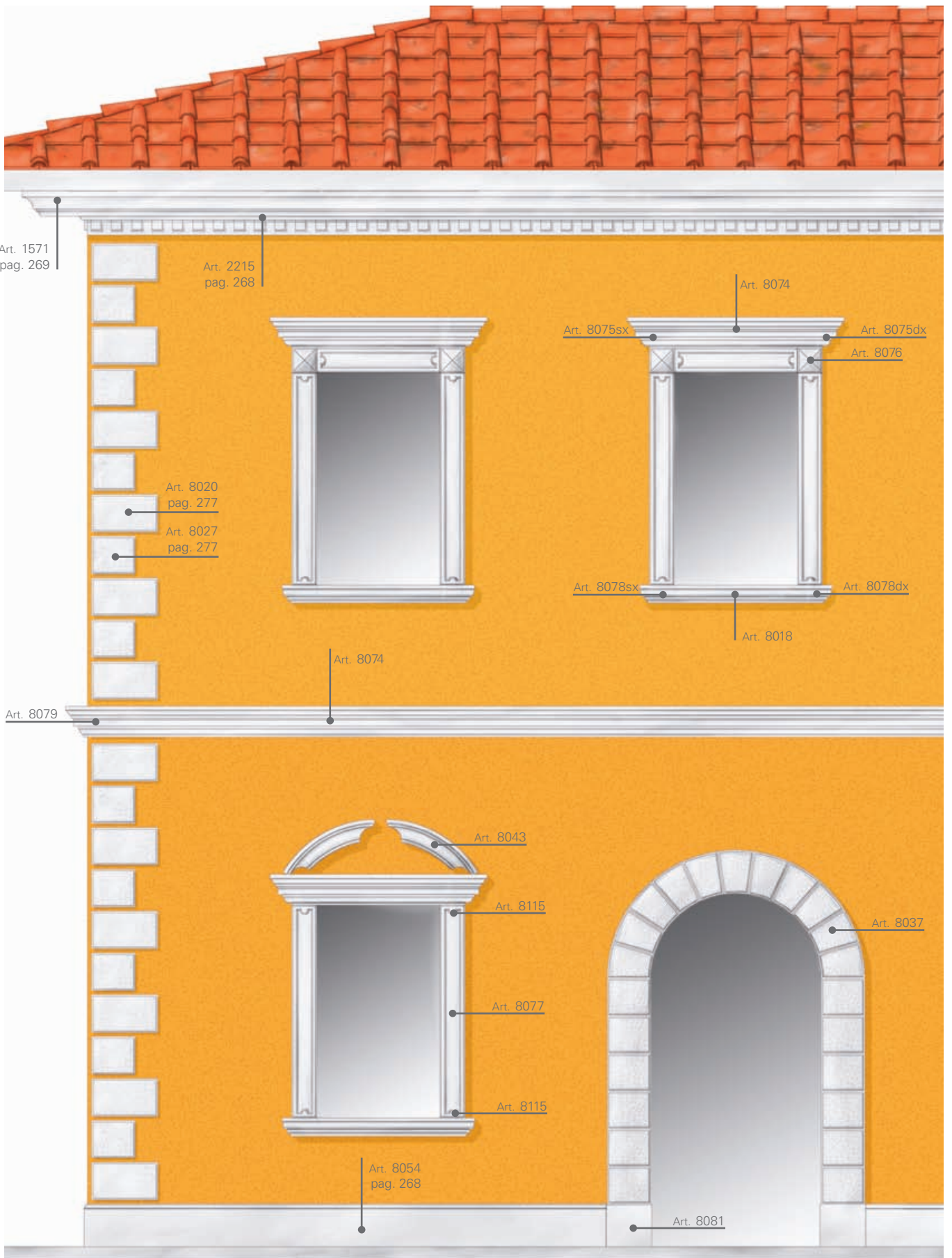

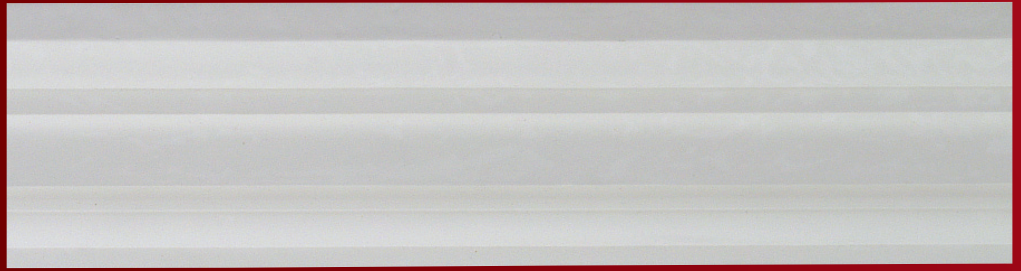
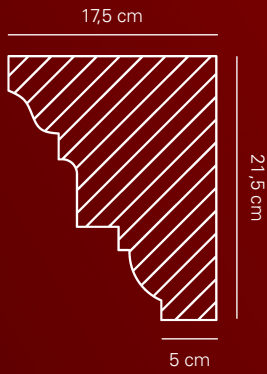

Art. 8074



Art. 8018



Art. 8077



Art. 8075 sx

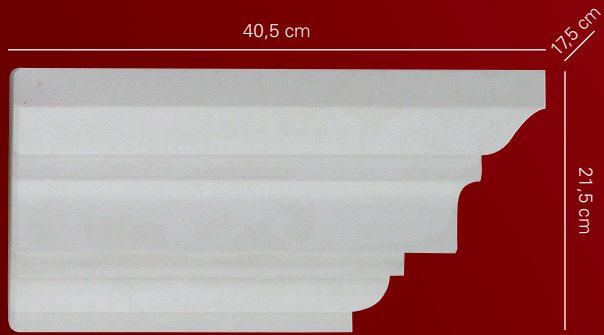

Art. 8075 dx
Sezione con / Section with art. 8074



Art. 8078 sx

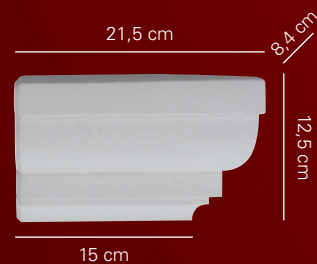

Art. 8078 dx
Sezione con / Section with art. 8018



Art. 8079
Sezione con / Section with art. 8074

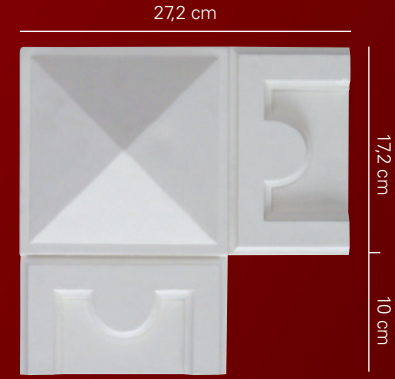

Art. 8076
Sezione con / Section with art. 8077

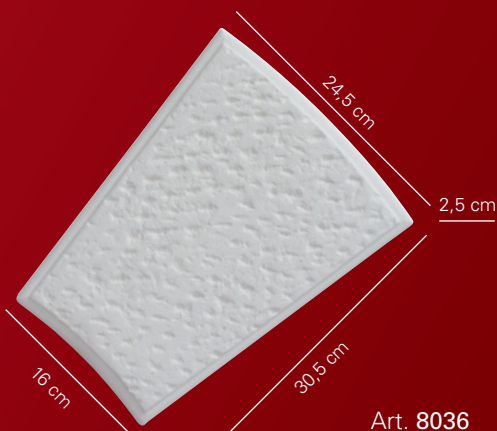

Art. 8036
Raggio interno / Internal radius 55 cm



Art. 8115
Sezione con / Section with art. 8077

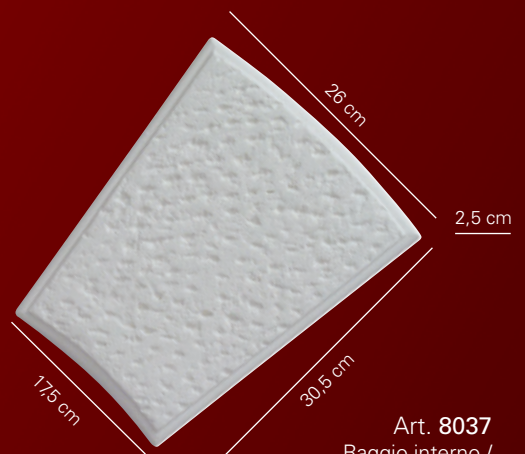

Art. 8037
Raggio interno / Internal radius 60 cm

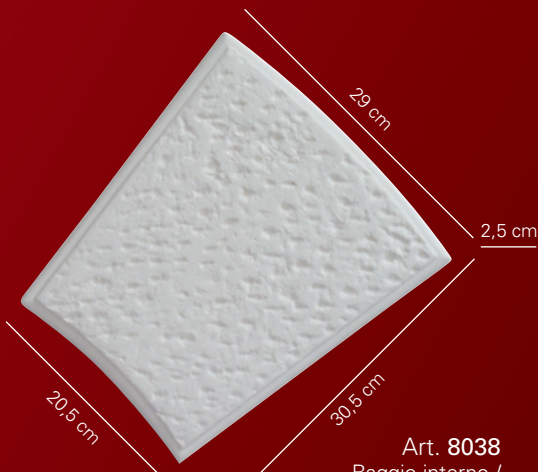

Art. 8038
Raggio interno / Internal radius 70 cm



Art. 8081
Zoccolo di base per / Base for art. 8027

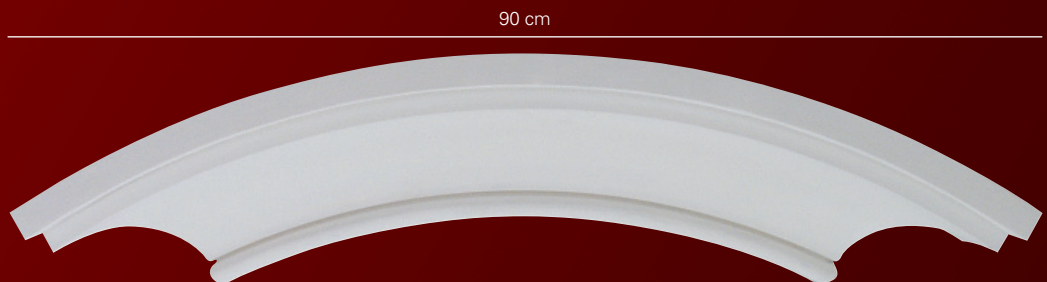
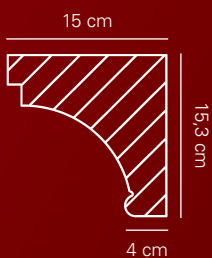

Art. 8043
Raggio interno 65 cm, raggio esterno 80,5 cm / Internal radius 65 cm, external radius 80,5 cm

Linea
Esterno

Outdoor Line



Fiorenza

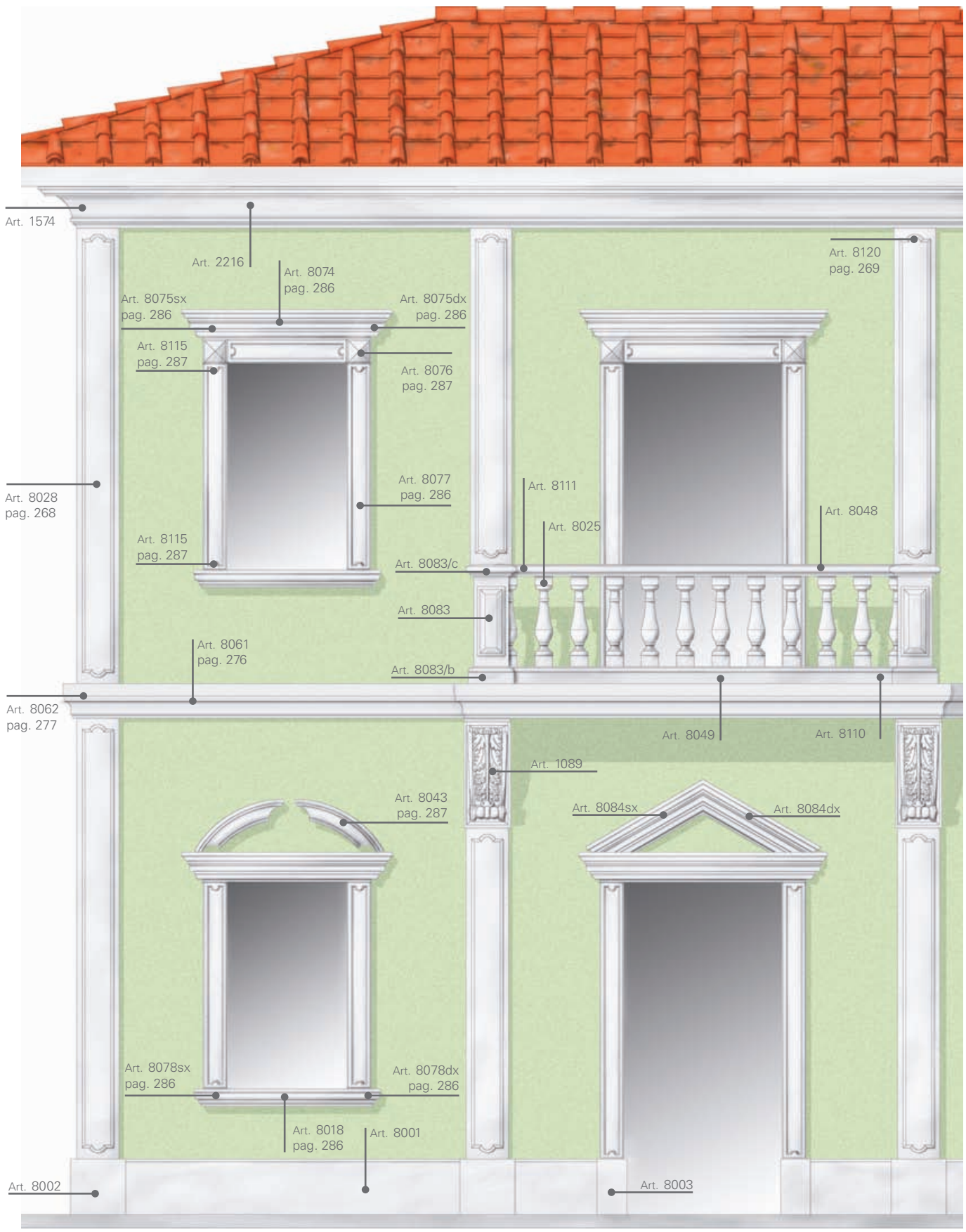

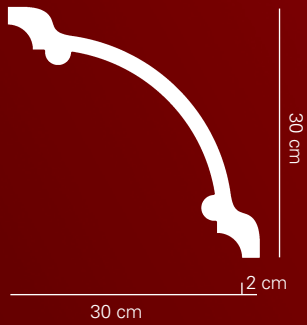

Art. 2216
Cornice sottogronda realizzata in gesso idrorepellente
Eave frame realized in water-repellent plaster



Art. 1574
Sezione con / *Section with* art. 2216
Realizzato in gesso idrorepellente
Realized in water-repellent plaster



Art. 8084 sx - dx
Sezione con /
Section with art. 8074

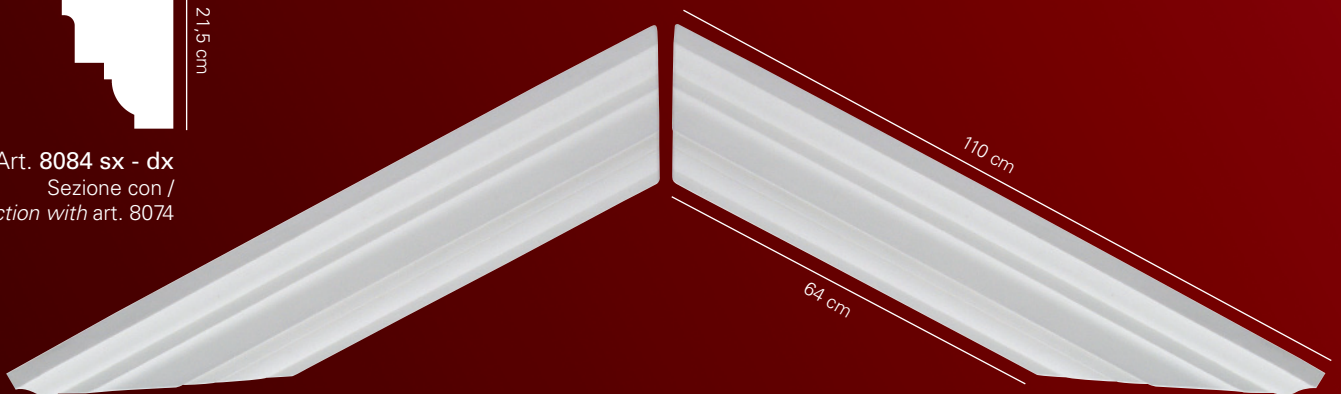

Art. 8084 sx

Art. 8084 dx



Art. 1089
Mensola realizzata in gesso idrorepellente
Shelf realized in water-repellent plaster

4 cm



40 cm



Art. 8001

32 cm

5 cm



40 cm

Art. 8002

Zoccolo di base per / Base for art. 8028

19 cm

5 cm



40 cm

Art. 8003

Zoccolo di base per / Base for art. 8077



Art. 8048

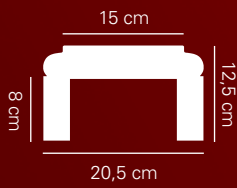

Art. 8049



Art. 8083



Art. 8025

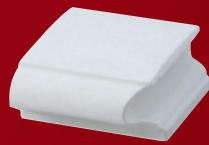

Art. 8111
Sezione con /
Section with art. 8048

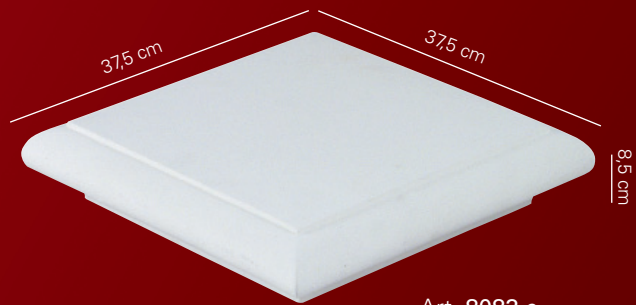

Art. 8083 c



Art. 8110
Sezione con /
Section with art. 8049

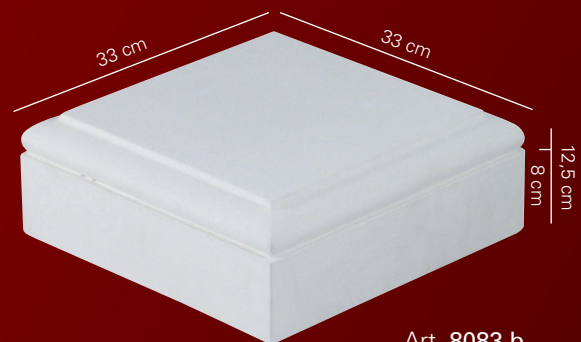

Art. 8083 b



Composizione d'insieme
Entire composition

A pagina 314 - 315 sono consultabili altri
articoli specifici per balaustre

Other articles for banisters and balustrades
are listed on page 314-315

Linea
Esterno

Outdoor Line

Arianna

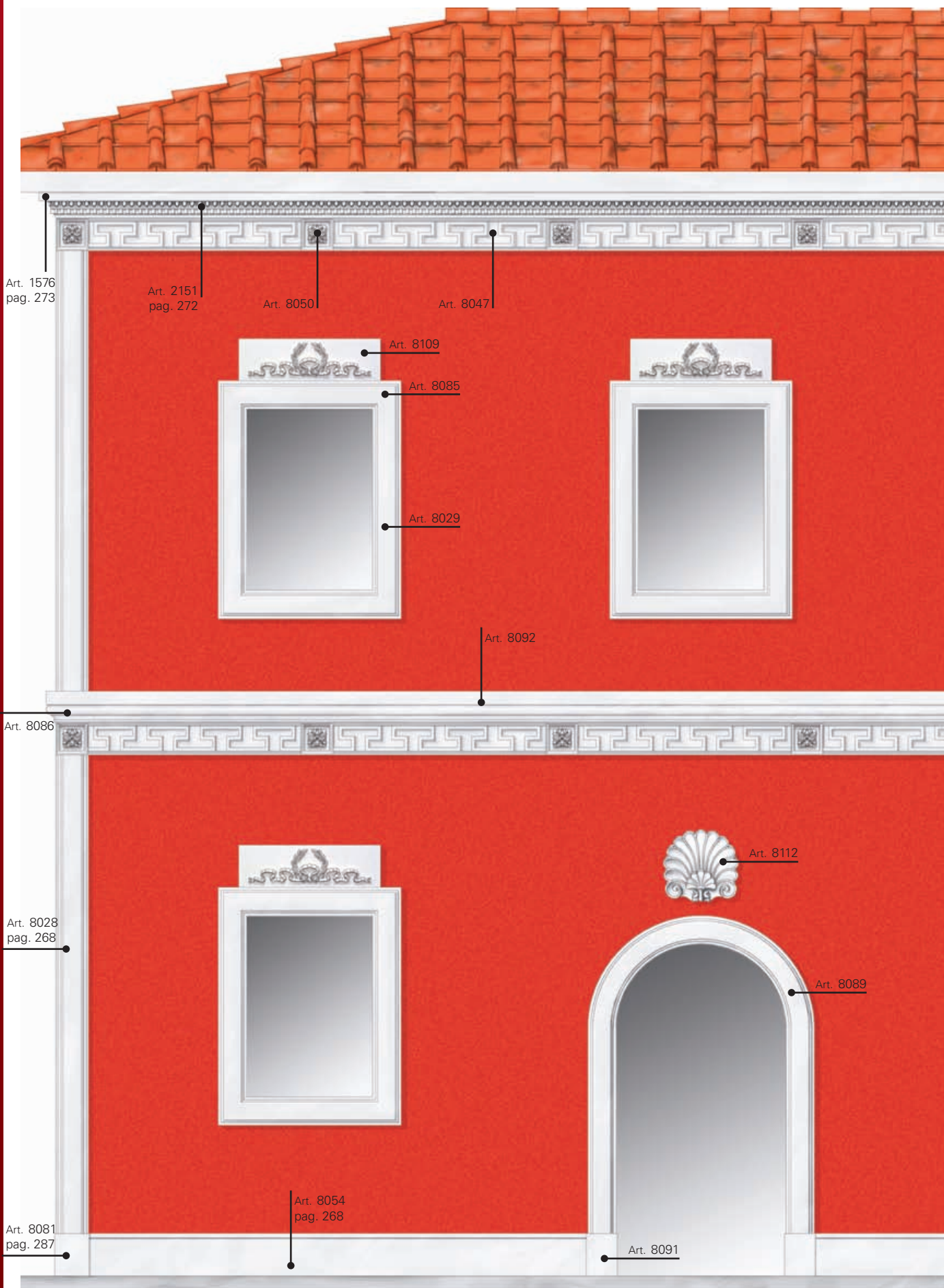



Art. 8092

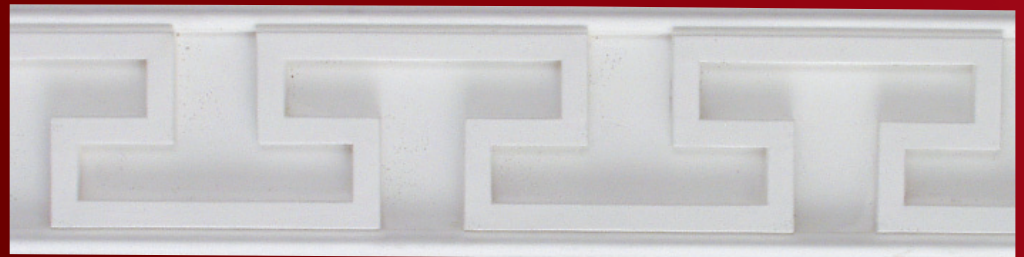

Art. 8047



Art. 8029



Art. 8109



Art. 8050

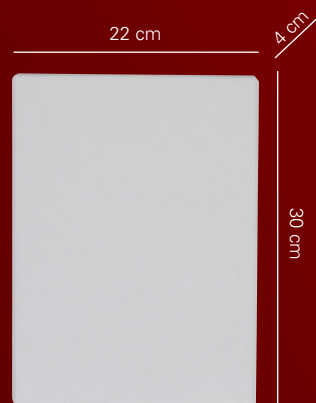

Art. 8091

Zoccolo di base per / Base for art. 8029



Art. 8086
Sezione con / Section with art. 8092



Art. 8088
1/4 di cerchio raggio interno /
1/4 circle internal radius cm 55
Sezione con / Section with art. 8029

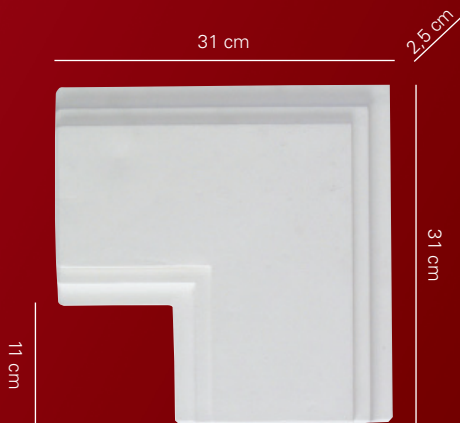

Art. 8085
Sezione con / Section with art. 8029



Art. 8089
1/4 di cerchio raggio interno /
1/4 circle internal radius cm 60
Sezione con / Section with art. 8029



Art. 8112



Art. 8090
1/4 di cerchio raggio interno /
1/4 circle internal radius cm 70
Sezione con / Section with art. 8029

Linea
Esterno

Outdoor Line

Egeo

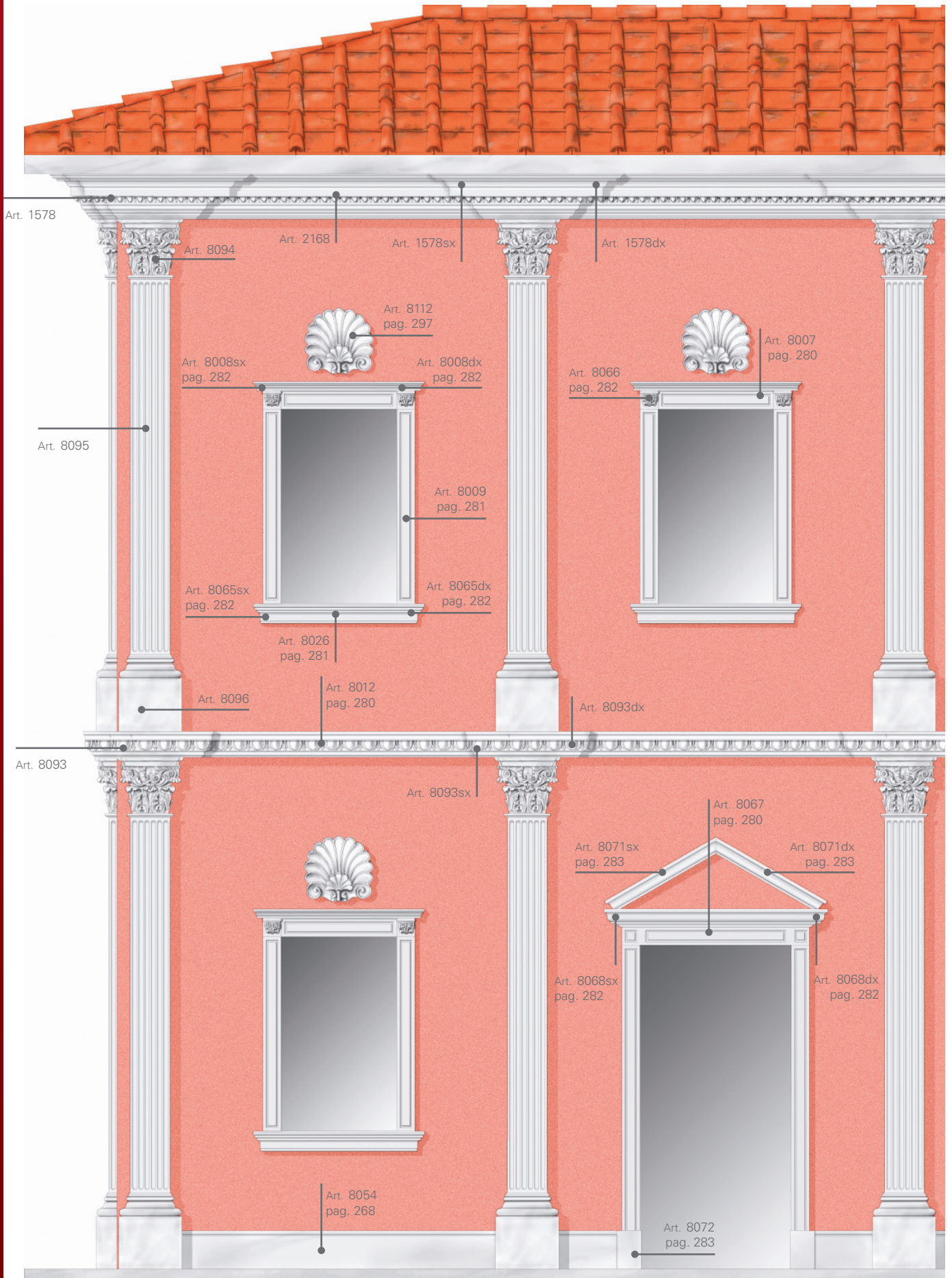

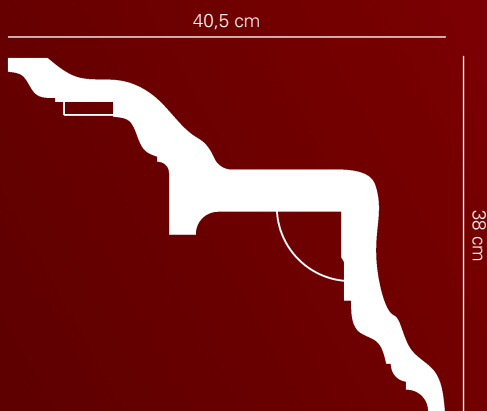

Art. 2168
Cornice sottogronda realizzata in gesso idrorepellente
Eave frame realized in water-repellent plaster

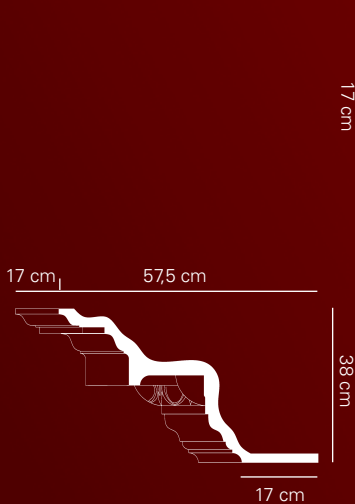

Art. 1578 sx
Moulding element with frame 2168
Realized in water-repellent plaster



Art. 1578 dx
Elemento per avanzamento con cornice 2168
Realizzato in gesso idrorepellente



Art. 1577
Sezione con / Section with art. 2168
Realizzato in gesso idrorepellente /
Realized in water-repellent plaster



Art. 1578
Spigolo con avanzamento con cornice /
Corner with moulding with frame art. 2168
Realizzato in gesso idrorepellente /
Realized in water-repellent plaster

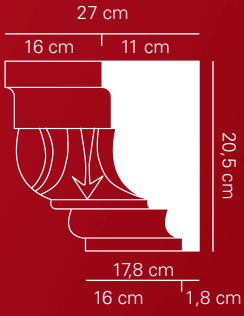

Art. 8093 sx



Art. 8093 dx
Elemento per avanzamento con cornice /
Moulding element with frame art. 8012

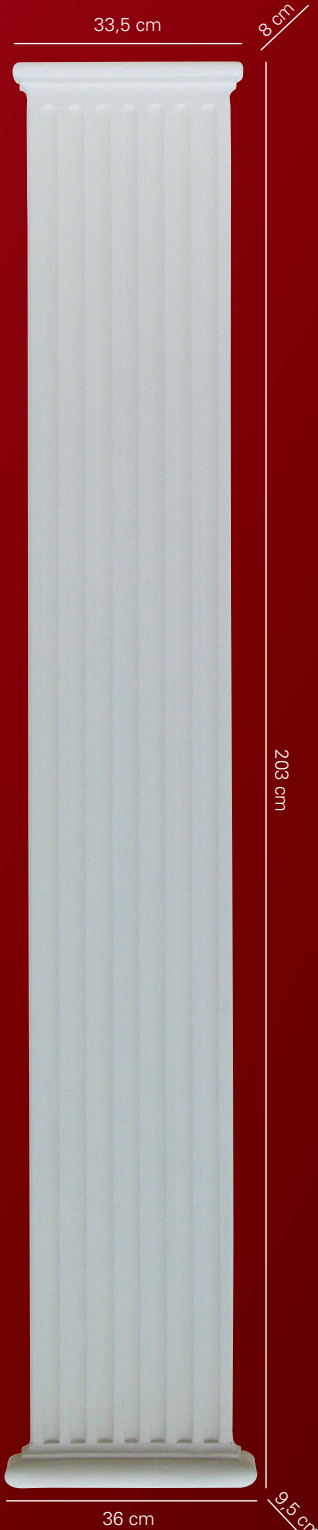
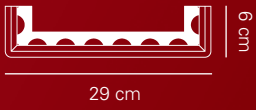

Art. 8095

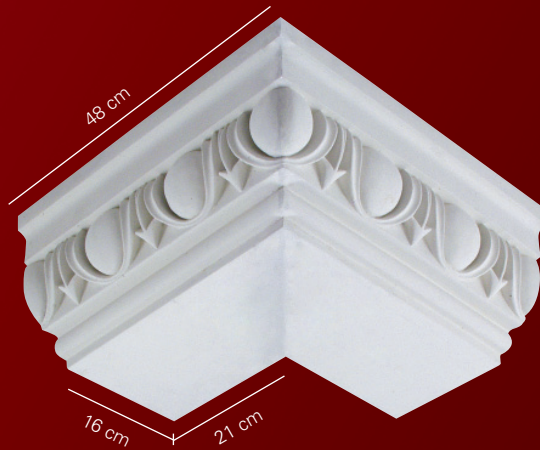

Art. 8093
Spigolo per avanzamento con / Moulding corner with art. 8012



Art. 8094



Art. 8096

Linea
Esterno

Outdoor Line

Le Grete

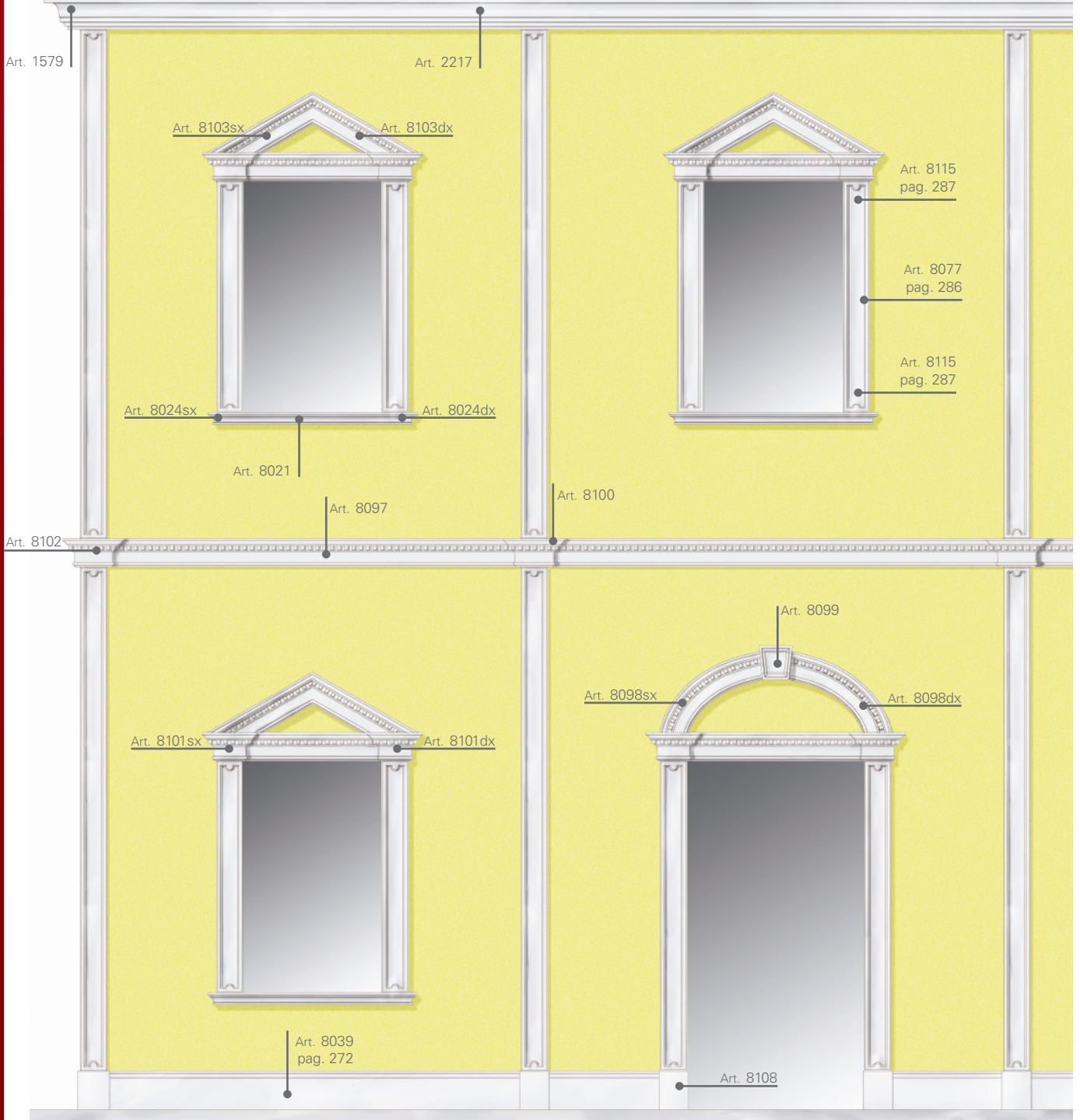

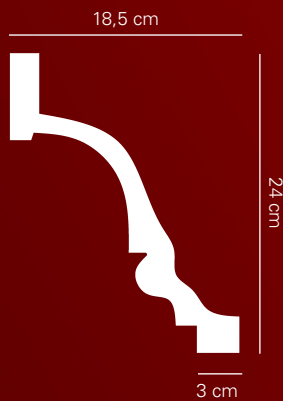

Art. 2217

Cornice sottogronda realizzata in gesso idrorepellente
Eave frame realized in water-repellent plaster



Art. 8097

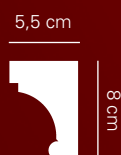

Art. 8021

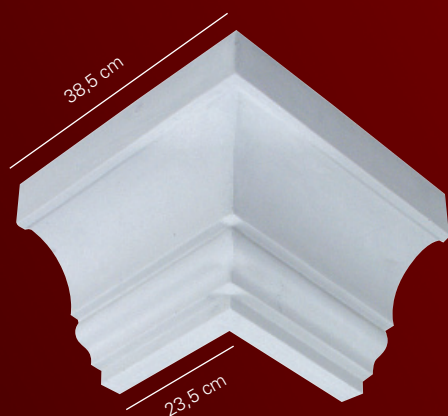

Art. 1579

Sezione con / *Section with art. 2217*
Realizzato in gesso idrorepellente
Realized in water-repellent plaster



Art. 8102

Spigolo con avanzamento / *Corner with moulding*
Sezione con / *section with art. 8100*

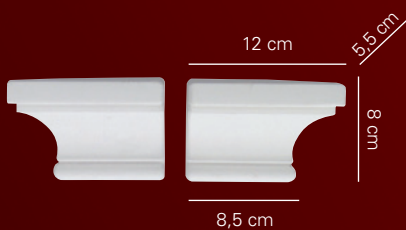

Art. 8024 sx

Art. 8024 dx

Sezione con / *Section with art. 8021*



Art. 8022

Sezione con / *Section with art. 8021*



Art. 8023

Sezione con / *Section with art. 8021*



Art. 8103 sx

Art. 8103 dx

Sezione con / section with art. 8097

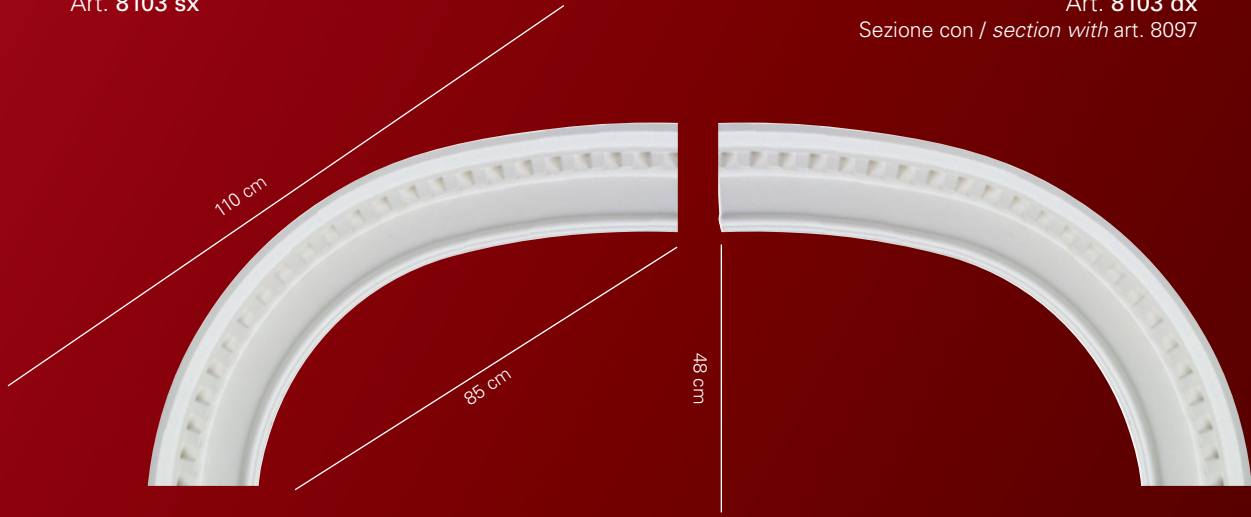

Art. 8098 sx

Art. 8098 dx

Sezione con / section with art. 8097

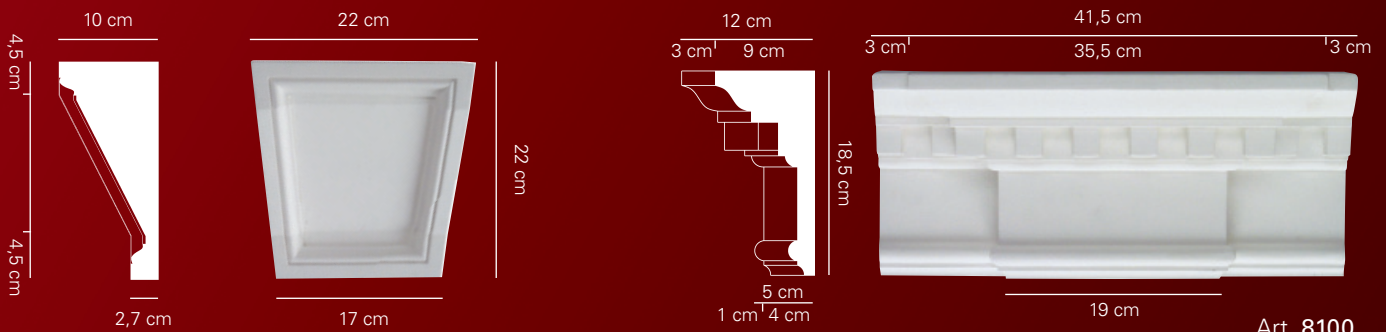

Art. 8099

Art. 8100

Elemento con avanzamento centrale, sezione con / Element with central moulding, section with art. 8097

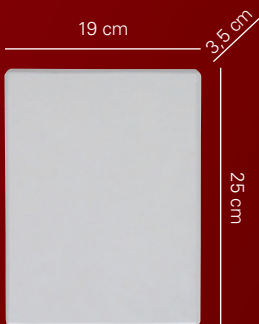

Art. 8108

Zoccolo di base per / Base for art. 8077

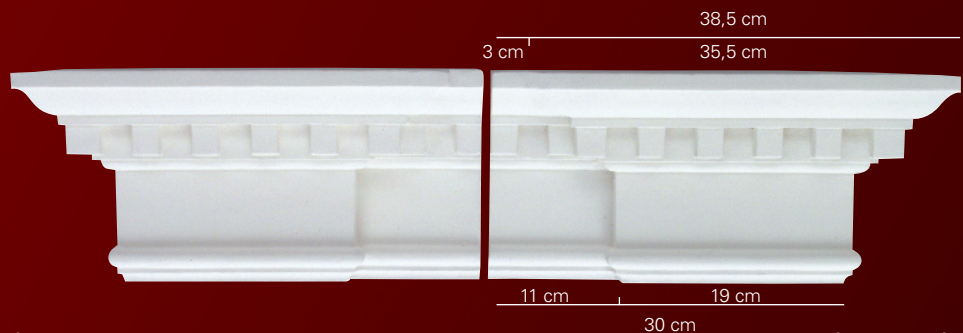

Art. 8101 sx

Side moulded body, section with art. 8100

Art. 8101 dx

Corpo avanzato laterale, sezione con art. 8100

Linea
Esterno

Outdoor Line

Accessori

Accessories

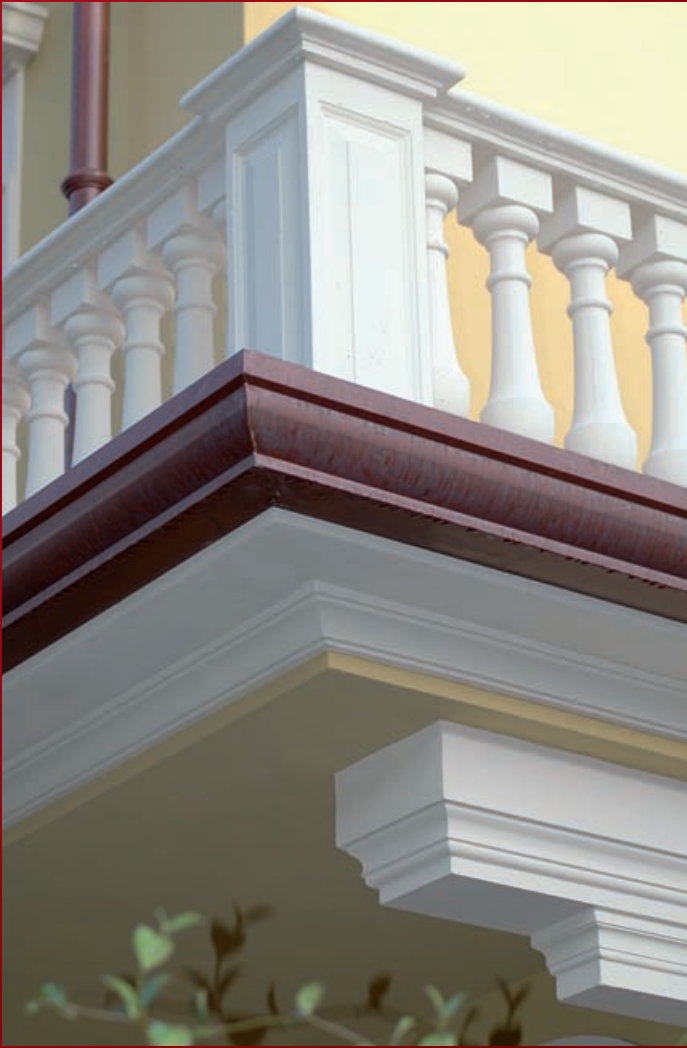

Abitazione privata - Viareggio (LU)
Private home

Villa Privata - Yerevan (Armenia)
Private villa



Abitazione Privata - Cerreto Guidi (FI)
Private home







Art. 1197
Realizzato in gesso idrorepellente
Realized in water-repellent plaster



Art. 1355
Realizzato in gesso idrorepellente
Realized in water-repellent plaster



Art. 1155
Realizzato in gesso idrorepellente
Realized in water-repellent plaster



Art. 1356
Realizzato in gesso idrorepellente
Realized in water-repellent plaster

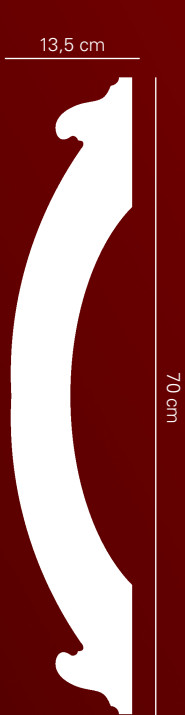

Art. 8080



Art. 8033



Art. 8032

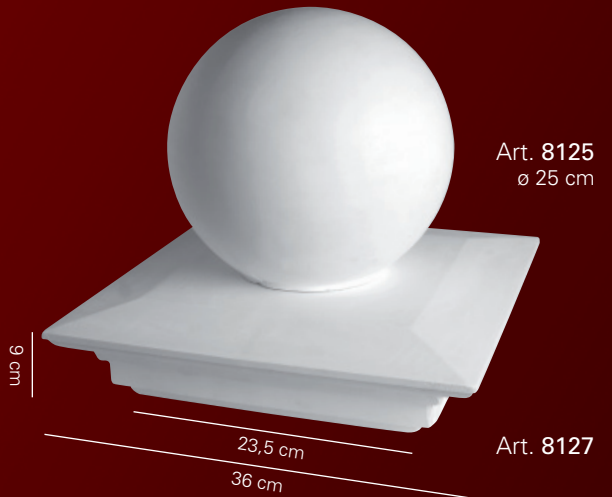
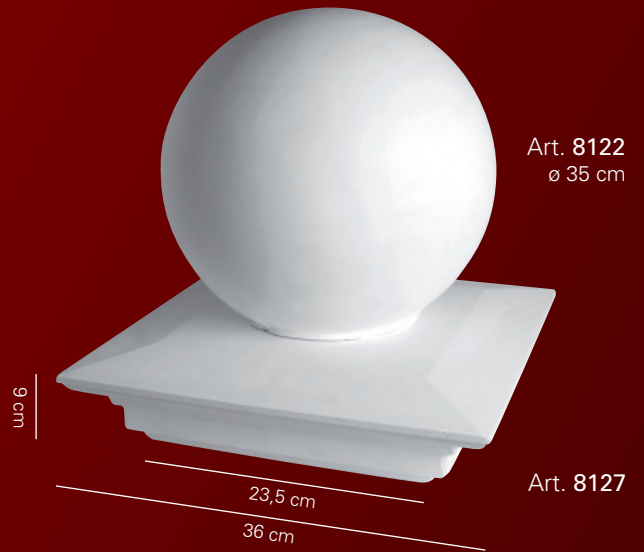
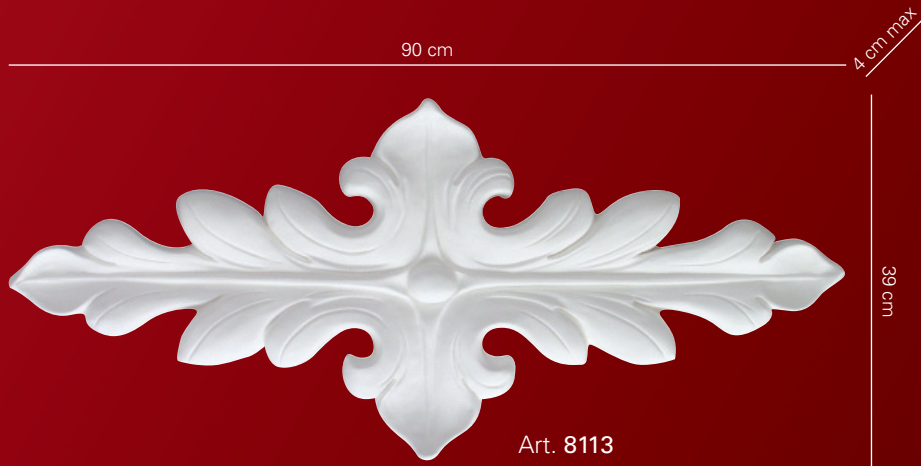

Architravi complete di terminali / Architrave frames complete with terminals

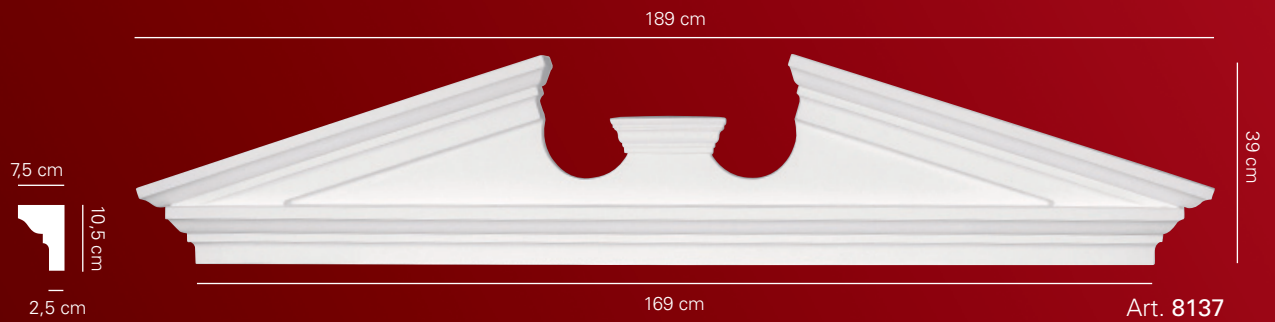

Sezione cornice applicata su un piano profondo 2,5 cm quindi la profondità di base del timpano è 5 cm
 Frame section applied on a 2.5 cm depth tympanum for an overall tympanum base depth of 5 cm



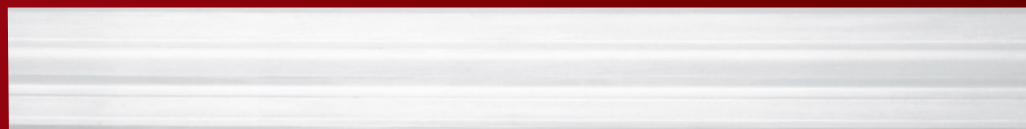

Art. 8130



Art. 8139

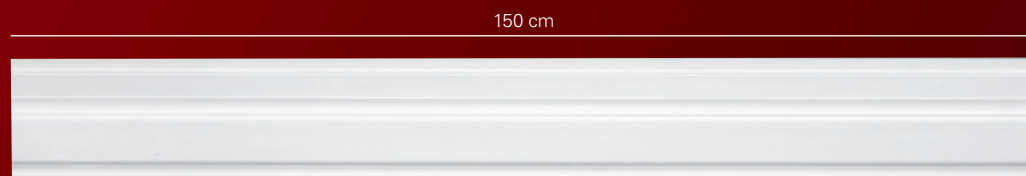

Art. 8135



Art. 8136sx

Art. 8136dx
Sezione con / Section with art. 8135

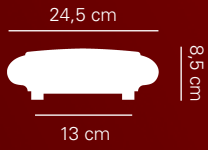

Art. 8048

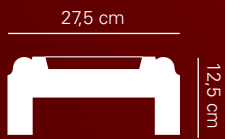

Art. 8118



Art. 8121



Art. 8119

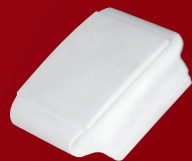

Art. 8111

Sezione con / Section with art. 8048
per collegamento art. 8048 con art. 8083 c
For joining art. 8048 and art. 8083 c

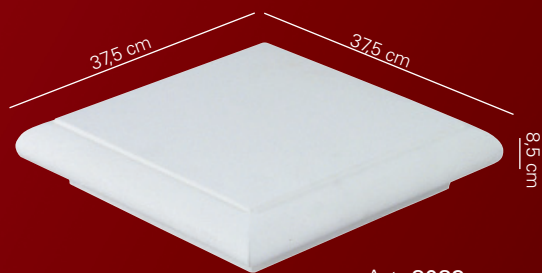

Art. 8083 c

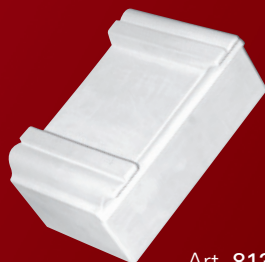
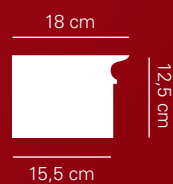

Art. 8138

Sezione con / Section with art. 8118
per collegamento art. 8118 con art. 8083 b
For joining art. 8118 and art. 8083 b

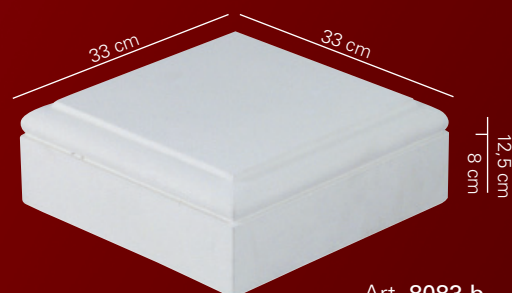

Art. 8083 b



Art. 8117

Sezione con / Section with art. 8118



Art. 8116

Sezione con / Section with art. 8048



Composizione d'insieme
Entire composition

Linea Collanti

La ASF Enterprise nel corso della sua esperienza ha messo a punto e realizzato una serie di adesivi per l'edilizia di ottima qualità che, per le loro eccellenti caratteristiche di adesione e lavorabilità, soddisfano le più importanti esigenze degli applicatori. Questa linea di prodotti nasce come naturale complemento per l'applicazione dei vari manufatti in gesso e malta cementizia prodotti dalla ASF Enterprise.

La gamma prodotti è stata ampliata con il nuovo **ES-STUCK**, lo stucco in polvere specifico per la malta cementizia.

Mastice per esterno ES-KOLL

Adesivo mono componente per esterni, idoneo per l'incollaggio dei manufatti in malta cementizia. Prodotto ad elevata deformabilità e scivolamento verticale nullo. Spessore di posa fino a 10 mm. Tempo di tenuta a 20 °C: circa 25 minuti.

Mastice per esterno ID-KOLL

Adesivo mono componente a lunga lavorabilità (90/120 minuti circa per esterni ed interni), idoneo per l'incollaggio dei manufatti in gesso idrorepellente. Tempo di tenuta a 20 °C: circa 15 minuti.

Mastice per interni EXTRA

Adesivo mono componente a lunga lavorabilità (90/120 minuti circa), con ottime qualità di tenuta; è eccellente come rasante. Ideale nella preparazione di sottofondi per la posa di carta da parati e delle nuove pitture vellutate. Tempo di tenuta a 20 °C: circa 25 minuti.

Mastice per interni NORMALE

Adesivo mono componente a normale lavorabilità (60/90 minuti circa), con buone qualità di tenuta. Per le sue caratteristiche risulta particolarmente idoneo per il montaggio dei manufatti in gesso e similari. Tempo di tenuta a 20 °C: circa 20 minuti.

Mastice per interni FORMULA 2000

Adesivo mono componente a lavorabilità medio/corta (60 minuti circa), con buone qualità di tenuta, particolarmente adatto nelle operazioni di stuccatura e per la posa di contro soffitti e pareti in cartongesso. Tempo di tenuta a 20 °C: circa 15 minuti.

Over their years of experience, ASF Enterprise have perfected a series of top-quality adhesives for the construction sector, which thanks to their excellent adhesive characteristics and workability meet all the primary needs of installers. This product line was developed as the natural complement for application of the various gypsum plaster and cement mortar articles manufactured by ASF Enterprise.

The product line now includes the new **ES-STUCK** filler, a powdered product specific for cement mortar.

ES-KOLL Adhesive for Exteriors

Single-component adhesive for exteriors, suitable for bonding cement mortar articles. High deformability and zero vertical slippage. Application layer thickness up to 10 mm. Open time at 20 °C: 25 minutes ca.

ID-KOLL Adhesive for Exteriors

Single-component adhesive featuring long pot life (90/120 minutes for indoor and outdoor applications), suitable for bonding water-repellent plaster articles. Open time at 20 °C: 15 minutes ca.

EXTRA Adhesive for Interiors

Single-component adhesive featuring long pot life (90/120 minutes) and excellent gripping qualities. Ideal as surface filler and for preparation of surfaces for wallpaper hanging and as a support for the new velvety-finish wall coatings. Open time at 20 °C: 15 minutes ca.

NORMALE Adhesive for Interiors

Single-component adhesive featuring average pot life (60/90 minutes) and good gripping. Especially suitable for installation of plaster moldings and similar articles. Open time at 20 °C: 20 minutes ca.

FORMULA 2000 Adhesive for Interiors

Single-component adhesive featuring average/short pot life (60 minutes ca.) and good gripping. Especially suited for plastering operations and installation of drywall false ceilings and walls. Open time at 20 °C: 15 minutes ca.



Linea Collanti

Collanti per Esterni / Adhesives for Exteriors



ES - Koll
 Confezione 10 kg
 Packaging 10 kg



ID - Koll
 Confezione 6 kg
 Packaging 6 kg

Collanti per Interni / Adhesives for Interiors



Normale
 Confezione 1 - 5 - 10 - 20 kg
 Packaging 1 - 5 - 10 - 20 kg



Extra
 Confezione 1 - 5 - 10 - 20 kg
 Packaging 1 - 5 - 10 - 20 kg

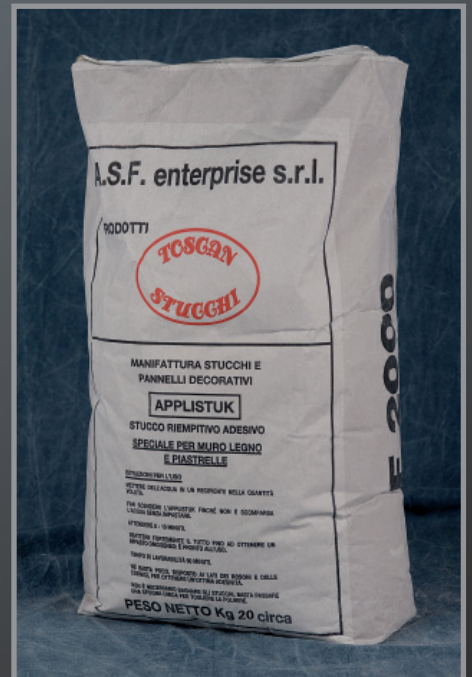

F - 2000
 Confezione 1 - 5 - 10 - 20 kg
 Packaging 1 - 5 - 10 - 20 kg

Il Prodotto e la sua installazione

LINEA GESSO

Come tutti i manufatti della A.S.F enterprise anche quelli della linea gesso sono stati concepiti per valorizzare l'aspetto architettonico e ornamentale di strutture ed immobili attingendo ad una vasta gamma di modelli ed altrettanti accessori che facilitano la scelta e la personalizzazione di progetti, suggerendo molteplici soluzioni.

Caratteristiche

Tutti i prodotti della linea Gesso sono stati realizzati con materiali di prima scelta appositamente studiati e opportunamente miscelati che consentono di ottenere un prodotto realizzato con tecniche innovative che valorizza al contempo l'intervento prevalente della lavorazione manuale.

In molti casi la competenza tecnica degli esperti della ASF enterprise permette di concretizzare linee o modelli personalizzati anche di notevole difficoltà realizzativa. Il manufatto per interno è progettato e realizzato per svolgere la propria funzione decorativa fissato o ancorato a pareti e/o soffitti di varia costituzione e natura purchè al riparo dalle intemperie.

Montaggio e manutenzione

Le operazioni di montaggio possono avvenire sia manualmente nei modi e termini previsti dalla vigente normativa in materia di sicurezza sul lavoro che con l'ausilio di apparecchi di sollevamento omologati e rispondenti ai requisiti di sicurezza previsti dalla normativa vigente.

In fase di montaggio a parete o a soffitto è necessario verificare preventivamente oltre alla potenziale portata della struttura anche la costituzione della muratura ed il suo stato di conservazione. In occasione della posa oppure durante la manutenzione può accadere che sia necessario intervenire sul pezzo mediante operazioni di foratura, scalpellatura, taglio ed interventi simili.

Per la documentazione completa per il montaggio e posa in opera la ASF Enterprise fornisce schede analitiche con tutte le specifiche e normative in uso.

LINEA ESTERNO

I prodotti della linea esterno sono stati realizzati con materiali appositamente studiati e opportunamente miscelati, come dimostrano i test di prova effettuati, e garantiscono una elevata resistenza nel tempo.

Caratteristiche

La base dei manufatti è una malta cementizia polimero modificata, fibrorinforzata a comportamento neoplastico che ha tra le altre caratteristiche una bassa porosità ed una elevata durata agli agenti atmosferici. Per i prodotti in gesso idrorepellente, la base è composta da gesso ceramico emidrato, che miscelato a prodotti idrorepellenti e fibre vegetali fa acquisire al prodotto finale una elevata resistenza all'umidità.

Il leggero degrado avvenuto solo superficialmente, in quanto i prodotti testati non sono stati protetti in alcun modo, è solo la condizione di normale invecchiamento dell'oggetto. Anche le prove effettuate in relazione agli sbalzi di temperatura e all'esposizione al gelo hanno dimostrato l'eccellente resistenza dei nostri prodotti. A tal fine sono disponibili a richiesta schede tecniche specifiche per ogni tipologia di prodotto dove sono evidenziati nel dettaglio i dati delle prove di laboratorio.

I prodotti della linea esterno pur avendo una elevata resistenza meccanica rispetto agli attacchi degli agenti atmosferici e una ottima durata nel tempo, hanno anche un peso specifico inferiore di circa il 40% rispetto ad un manufatto realizzato in cemento tradizionale. Questo consente una maggiore rapidità e facilità di applicazione oltre ad allargare il campo delle possibilità di impiego.

Montaggio e manutenzione

I valori di durata e resistenza dei prodotti della linea esterno possono aumentare mediante l'applicazione di tinte specifiche per esterno. Tali prodotti oltre a conferire la colorazione desiderata, aumentano la durata del manufatto in quanto creano una barriera agli agenti atmosferici. Se vengono eseguite con regolarità le operazioni di manutenzione ordinaria sopra descritte, i prodotti per esterno hanno una durata pressoché illimitata.

Product Installation

GYPSUM LINE

Like all ASF Enterprise products, the Gypsum Line moldings are designed to enhance the architectural and ornamental impact of buildings and constructions in general. The extensive selection of basic models and complementary accessories offers designers/users a wide choice of articles for customizing any project and suggests myriad solutions to design needs.

Technical Features

All the Gypsum Line products are manufactured from thoroughly-researched, top-quality raw materials combined in special mixes.

The result is a technologically innovative product line that nevertheless fully valorizes the prevailing contribution of hand-crafting: in many cases, the experience and technical know-how of ASF Enterprise's experts are key factors in translating new, often highly complex, product ideas and customized designs into "concrete" forms. The Gypsum Line products for interiors are designed and constructed for application/anchoring to walls and/or ceilings for ornamental purposes; they are suitable for use on many types of supports protected from atmospheric agents.

Assembly and Maintenance

Assembly/installation can be performed manually in observance of the prescriptions of pertinent safety-at-work regulations or using type-approved lifting equipment meeting relevant safety standards.

Wall and ceiling installations require prior verification of the load-bearing capacity of the structure as well as the makeup of the support masonry and its state of preservation.

During installation or maintenance it may be necessary to adjust a piece by drilling, chiseling, cutting, and/or similar methods.

ASF Enterprise can provide complete assembly and installation documentation, including analytical data sheets reporting all the specifications and applicable standards and regulations.

OUTDOOR LINE

The Outdoor Line products are molded from thoroughly-researched, specially-mixed materials. Extensive product testing has confirmed the high resistance and long life that are essential characteristics of these materials.

Technical Features

The basic material from which the Outdoor Line products are molded is a polymer-modified cement mortar with natural-fiber reinforcement, featuring high plasticity, low porosity, and excellent resistance to atmospheric agents. The water-repellent plaster products are molded in hemihydrate ceramic plaster mixed with water-repellent additives and natural fibers to lend high resistance to humidity to the final product.

Any slight degradation noted during testing, limited to the surfaces since the test products are in no way protected, is equivalent to normal product aging. Our products also demonstrated excellent resistance when subjected to rapid temperature change and freeze tests. Specific technical data sheets detailing the laboratory test results, by product type, are available on request. In addition to their high mechanical resistance to atmospheric agents and long life, the Outdoor Line products feature 40% lower specific weight than equivalent products in traditional concrete, for faster, easier assembly/installation as well as a considerably broader range of possible applications.

Assembly and Maintenance

The life and resistance of the Outdoor Line products can be increased if they are finished with the specific coatings developed for exterior use, which besides giving the product the desired color they increase product life by creating an efficacious barrier against atmospheric agents. If routine surface maintenance is carried out punctually, the life of the Outdoor Line products is practically unlimited.

A.S.F. enterprise
TOSCAN STUCCHI

Le misure degli articoli riportate nel presente catalogo sono puramente indicative e non costituiscono impegno determinante per la ditta costruttrice, la quale si riserva il diritto di cambiare o apportare modifiche atte a migliorare il prodotto a suo insindacabile giudizio.

The sizes of the items in this catalogue are purely indicative and not binding for the manufacturer who reserves the right to change or improve the product at his own unquestionable judgement.

Progettazione e realizzazione grafica
Concept and design
Edro 21 srl

Foto dei prodotti / *Product images*
Franco Ficeli
Marco Bonucci
ASF Enterprise

Immagini / *Images*
ASF Enterprise

Stampato a Certaldo nel mese di dicembre 2008 da
Printed in Certaldo in december 2008 by
FEDERIGHI COLORGRAFICHE



A.S.F. enterprise srl

53034 - Colle di Val D'Elsa - Siena (Italy)
Località Pian dell'Olmino Santa Giulia, 57/58
Tel. +39 0577 929224 - Fax +39 0577 929154
www.asfenterprise.com - infoasf@asfenterprise.com