

COMMERCIAL FLOORING SOLUTIONS

gerflor.com



2017/2018 COLLECTION

Gerflor[®]
theflooringgroup

EDITORIAL

ARCHITECTURE, DECORATION, SPORT, TECHNOSPECIFIC. **FLOORING SOLUTIONS FOR PROFESSIONAL APPLICATIONS**

GERFLOR, EXPERT AND LEADER IN GLOBAL SOLUTIONS FOR RESILIENT FLOORS, WALL COVERINGS, ACCESSIBILITY, FROM INSTALLING TO FINISHING FOR ALL PROFESSIONAL APPLICATIONS

For more than 70 years and in more than 100 countries, Gerflor is recognized as an expert in its field thanks to technical, decorative and eco-responsible added value solutions specific to each market application (healthcare, retirement homes, retail, industry, education, social housing, offices, sports...).

The Gerflor Group is well known as being the official supplier for the most famous and demanding worldwide customers and events such as Boeing, Carrefour and Olympic games.

Gerflor has been committed to creating solutions that continue to anticipate and meet the needs of customers around the globe. Our expertise in research and development as well as our manufacturing capabilities are focused on meeting each of our markets' requirements.

OUR GOAL IS TO OFFER MORE AND MORE GLOBAL SOLUTIONS

Our product offer aims to be functional and global; it goes far beyond our flooring range and includes SPM wall protection and handrails, ROMUS profiles, tools and door mats (2 companies which belong to the Gerflor Group), as well as complementary solutions for:

- optimising floor fitting (tools, welding etc.)
- achieving a perfectly finished site (skirtings, stair-noses etc.)
- resolving specific technical problems (shower systems, accessibility in establishments open to the public etc.).

WE PROVIDE YOU WITH ENVIRONMENTALLY RESPONSIBLE SOLUTIONS

All Gerflor production sites are ISO 14001 certified. We set ourselves the highest standards when it comes to environmental quality.

Gerflor uses recycled materials across all our product ranges. Our new generation of loose lay products reduces the use of adhesives and facilitates recovery and recycling at the end of the product's life. We also strongly promote durable and renewable material integration and 100% vegetal plasticizers in our product offer. In addition, our products are easy to maintain throughout their lives and qualify for credits under many internationally accredited Green Building Schemes.

This catalogue is a showcase of all our competencies across all market segments. We hope it will be a helpful resource for you and contribute to the success of your projects.

Always more inspiration, well being, security, performance and return on investment.

Bertrand CHAMMAS
C.E.O. of the Gerflor Group

▶ HOMOGENEOUS FLOORING

P.8

▶ Evercare™

- Mipolam Symbioz™
- Mipolam Esprit
- Mipolam Affinity **NEW**
- Mipolam Accord **NEW**
- Mipolam Elegance
- Mipolam Cosmo **NEW**
- Mipolam Troplan

▶ PUR

- Mipolam Classic **NEW**

▶ PU

- Architecton

▶ MULTILAYERED FLOORING

P.36

▶ Taralay Premium

- Osmoz
- Indiana
- Metallica
- Brazilia
- Costa Rica
- Fusion
- My Taralay
- Dry-Tex™ System

▶ Taralay Element

- City

▶ Taralay Impression / Uni **NEW**

- Corner
- Kubes
- Rice
- Stars
- Cemento

- Mohair

- Nest
- Trame
- Gentlemen
- Wood
- Uni

▶ Taralay Initial

- NEW**
- Diversion
- Fantasy
- Strada
- Urban
- Tweedy
- Wood

▶ Tarastep

▶ LUXURY VINYL TILE

P.90

▶ Saga² **NEW**

▶ Creation 70

- Creation 70
- "Exclusive Edition" **NEW**
- Creation 70
- Creation 70 Clic System
- Creation 70 X'Press

▶ Creation 55

- Creation 55
- "Exclusive Edition" **NEW**
- Creation 55
- Creation 55 Clic System
- Creation 55 X'Press

▶ Creation 30

- Creation 30
- Creation 30 Lock
- Creation 30 X'Press

▶ FAST TRACK LOOSELAY TILE

P.192

▶ GTI EL5

▶ GTI MAX **NEW**

▶ Attraction® **NEW**

▶ SPECIALITY FLOORING

P.208

▶ Static control Mipolam EL

- Accord EL7 Evercare™ **NEW**
- Elegance EL5 Evercare™ **NEW**
- Robust EL7
- Technic EL5
- GTI EL5

▶ Safety flooring

- Tarasafe Geo
- Tarasafe Ultra & Ultra Comfort
- Tarasafe Ultra H2O
- Tarasafe Standard
- Tarasafe Plus/Super

▶ Shower System

- Elegance SD
- Tarasafe Ultra H2O
- Mural Calypso

▶ Wall Covering

- Mural Ultra
- Mural Club
- Mural Calypso

▶ SPORTS FLOORING

P.236

▶ TARAFLEX™ Sports Flooring

▶ Hardwood flooring systems CONNOR SPORTS®

▶ Outdoor play areas SPORT COURT

▶ FINISHES AND TECHNICAL SOLUTIONS

P.270

▶ Finishes

- Skirting solutions
- Stair solutions
- Profile solutions
- Welding solutions

▶ Specialized finishes

- Paint and marking for boundary lines

▶ Technical solutions

- Shower system
- Floor protection **NEW**
- Clean Corner System
- Safe' Cap **NEW**
- Specific features
- Glues and adhesives
- Tools

▶ SPECIFICATIONS - INSTALLATION - MAINTENANCE

P.312









GLOSSARY

FORMATS

With foam backing (Comfort)

| | | |
|----------------------------------------------------------------------------------------------|----------------------------------------------------------------------------------------------|----------------------------------------------------------------------------------------------|
|  Comfort |  Comfort |  Comfort |
| ROLL | STEP | REMOVABLE TILE |

Without foam backing (Compact)

| | | | | | | | |
|----------------------------------------------------------------------------------------------|----------------------------------------------------------------------------------------------|----------------------------------------------------------------------------------------------|----------------------------------------------------------------------------------------------|----------------------------------------------------------------------------------------------|----------------------------------------------------------------------------------------------|--------------------------------------------------------------------------------------------------------------------------|--------------------------------------------------------------------------------------------------------------------------|
|  Compact |  Compact |  Compact |  Compact |  Compact |  Compact |  Pressure Sensitive Adhesive (PSA) |  Pressure Sensitive Adhesive (PSA) |
| ROLL | TILE | PLANK | REMOVABLE TILE | REMOVABLE PLANK | INTERLOCKING LOOSE LAY TILE | Pressure Sensitive Adhesive (PSA) | Pressure Sensitive Adhesive (PSA) |

PERFORMANCES

| | | |
|----------------|------------------------------------------|------------------------------------|
| T/P | 17dB | R10 |
| ABRASION GROUP | SOUND INSULATION IN dB (EN ISO 717/2) | SLIP RESISTANCE WET (DIN 51130) |

| | | |
|-------------------------------------------------------------------------------------------------|-----------------------------------------------------------------------------------------------|---------------------------------------------------------------------------------------------------|
| 10⁵ | 10⁷ | VHD  |
| ELECTRICAL RESISTANCE IN Ω : 5X10 ⁴ ≤ Rt ≤ 10 ⁵ (EN 1081/DIN 51953) | ELECTRICAL RESISTANCE IN Ω : 10 ⁶ ≤ Rt ≤ 10 ⁸ (EN 1081/DIN 51953) | VERY HIGH DENSITY FOAM |

| | |
|---------------------------------------------------------------------------------------------------------------|-------------------------------------------------------------------------------------|
|  100% recyclable |  |
| 100% RECYCLABLE FLOORING | RECYCLABLE FLOORING |









TREATMENTS

| | | |
|---------------------------------------------------------------------------------------------------------------------|-----------------------------------------|---------------------------------------------------------------------------------------------------------------------|
|  PROTECSOL² | ProtecSol[®] |  everCare[™] |
| POLYURETHANE SURFACE TREATMENT UV CURED STAIN SHIELD MATT EFFECT | POLYURETHANE SURFACE TREATMENT UV CURED | MICRO STRUCTURED CROSS COAT POLYMERISED LASER TECHNOLOGY |

| | | | |
|--------------------------------|--------------------------------|----------------------|------------------------------|
| PUR+ | PUR | PU | SparClean[®] |
| POLYURETHANE SURFACE TREATMENT | POLYURETHANE SURFACE TREATMENT | PU SURFACE TREATMENT | POWDER COATED TREATMENT |

CERTIFICATION



| | | | | | | | | |
|-----------------------------------------------------------------------------------------------------------|-----------------------------------------------------------------------------------------------------------|----------------------------------------------------------------------------------------------------------|-------------------------------------------------------------------------------------|-----------------------------------------------------------------------------------------------------------|-----------------------------------------------------------------------------------------------------------|-------------------------------------------------------------------------------------------|--------------------------------------------------------------------------------------|---------------------------------------------------------------------------------------|
|  B _{fl-s1} |  C _{fl-s1} |  B _{s2d0} |  |  ≤10 ⁶ Ω |  ≤10 ⁹ Ω |  DS |  |  |
| FIRE RESISTANCE | FIRE RESISTANCE | FIRE RESISTANCE | STATIC ELECTRICAL PROPENSITY | ELECTRICAL RESISTANCE | ELECTRICAL RESISTANCE | SLIP RESISTANCE | THERMAL CONDUCTIVITY | WATER RESISTANCE |

Scale reduction for Wood designs.

The images of floorcoverings in this catalogue have been reproduced as faithfully as printing technology permits.

| | | |
|----------|-------------------------------------------------|-----------------|
| A | | |
| NEW | • Accessibility | 302 |
| | • Accord EL7 (Mipolam EL) | 214 |
| | • Adhesives & tapes | 308 |
| NEW | • Architecton | 35 |
| | • Attraction® | 204 |
| B | | |
| | • Bateco | 299 |
| | • Brazilia | 49 |
| C | | |
| NEW | • Cemento | 66 |
| NEW | • Charme | 71 |
| | • City | 58 |
| | • Clean Corner System | 304 |
| | • Connor Sports® (Hardwood Flooring Systems) | 260-265 |
| | • Copper strip | 300 |
| NEW | • Corner | 62 |
| | • Costa Rica | 50 |
| | • Creation 70 | 106-115 |
| | • Creation 70 Clic System | 116-123 |
| NEW | • Creation 70 Exclusive Edition | 100-105 |
| | • Creation 70 X'Press | 124-127 |
| | • Creation 55 | 138-149 |
| | • Creation 55 Clic System | 150-159 |
| NEW | • Creation 55 Exclusive Edition | 132-137 |
| | • Creation 55 X'Press | 160-163 |
| | • Creation 30 | 168-177 |
| | • Creation 30 Lock | 178-183 |
| | • Creation 30 X'Press | 184-187 |
| | • Creation accessories | 130 & 166 & 190 |
| D | | |
| | • Diversion | 78 |
| | • Dry-Tex™ System | 54 & 255 & 296 |
| E | | |
| | • Elegance EL5 (Mipolam EL) | 215 |
| | • Elegance SD | 228 |
| | • Entrance solutions (Romus) | 286 |
| | • ESD Solutions (Mipolam EL) | 212 |
| | • Esterel | 85 |
| F | | |
| NEW | • Filament | 82 |
| | • Finishes & Technical solution | 270-311 |
| NEW | • Floor Protection | 299 |
| | • Fusion | 51 |
| G | | |
| NEW | • Gentlemen | 68 |
| | • GTI EL5 | 200 & 216 |
| NEW | • GTI MAX | 196 |
| H | | |
| | • Habana (Taralay Initial) | 85 |
| NEW | • Habana (Taralay Impression) | 69 |
| NEW | • Herringbone | 69 |
| I | | |
| | • Indiana | 44 |
| NEW | • Infinity | 73 |
| | • Isolsport | 299 |
| K | | |
| NEW | • Kubes | 63 |
| L | | |
| NEW | • Loft (Taralay Impression) | 71 |
| M | | |
| | • Maintenance products | 300 |
| | • Metallica | 47 |
| NEW | • Mipolam Accord | 24 |
| NEW | • Mipolam Affinity | 22 |
| NEW | • Mipolam Classic | 34 |
| NEW | • Mipolam Cosmo | 29 |
| | • Mipolam EL (ESD Solutions) | 212 |
| | • Mipolam Elegance | 26 |
| | • Mipolam Esprit | 20 |
| | • Mipolam Symbioz™ | 14 |
| | • Mipolam Troplan | 30 |
| NEW | • Mohair | 66 |
| NEW | • Moon Island | 72 |
| | • Mural Calypso | 229 & 235 |
| | • Mural Club | 234 |
| | • Mural Ultra | 234 |
| | • My Taralay Premium | 52 |
| N | | |
| NEW | • Nest | 67 |
| | • Noma (Taralay Initial) | 85 |
| NEW | • Noma (Taralay Impression) | 72 |
| O | | |
| | • Osmoz | 43 |
| NEW | • Ottawa | 83 |
| P | | |
| NEW | • Portobello | 72 |
| | • Profile solutions | 281-283 |
| R | | |
| | • Renzo (Taralay Initial) | 83 |
| NEW | • Renzo (Taralay Impression) | 73 |
| NEW | • Rice | 64 |
| | • Robust EL7 (Mipolam EL) | 214 |
| | • Romus (Entrance solutions) | 286-287 |
| S | | |
| | • Safety flooring | 218 |
| NEW | • Saga ² | 97-99 |
| NEW | • Safe Cap | 306 |
| | • Shower System (Taradouche) | 226 & 291 |
| | • Skirting solutions | 273-277 |
| | • Specific products | 298-305 |
| | • Sport Court (Outdoor Play Areas) | 266-269 |
| | • Sport finishes | 288-289 |
| | • Sports Flooring | 236-269 |
| | • Stair solutions | 278-280 |
| NEW | • Stars | 65 |
| NEW | • Strada | 79 |
| NEW | • Sycamore | 70 |
| T | | |
| | • Taradouche Shower System | 226 & 291 |
| | • Taraflex™ Sports Flooring | 242-259 |
| | • Tarafoam | 299 |
| | • Taralay Element | 56 |
| | • Taralay Impression | 60 |
| | • Taralay Initial | 76 |
| | • Taralay Premium | 40 |
| | • Tarasafe Geo | 221 |
| | • Tarasafe Standard | 225 |
| | • Tarasafe Plus / Super | 225 |
| | • Tarasafe Ultra | 223 |
| | • Tarasafe Ultra H ₂ O | 224 & 228 |
| | • Tarasafe Ultra Comfort | 223 |
| | • Tarastep | 86 |
| | • Technic EL5 (Mipolam EL) | 215 |
| | • Tools | 310 |
| NEW | • Trame | 68 |
| NEW | • Tweedy | 81 |
| U | | |
| NEW | • Uni (Taralay) | 75 |
| NEW | • Urban | 80 |
| W | | |
| | • Wall covering | 232 |
| NEW | • Walnut | 71 |
| | • Welding solutions | 284-285 |
| NEW | • Wood (Taralay Initial) | 82-85 |
| NEW | • Wood (Taralay Impression) | 69-73 |

GERFLOR

ALL OVER THE WORLD GERFLOR INVENTS FOR YOU

9 MARKETS



HEALTHCARE



RETAIL



HOUSING



INDUSTRY



SPORT



EDUCATION



HOSPITALITY



OFFICES



TRANSPORT

Worldwide presence and proximity to our customers through:

26 subsidiaries and a broad network of partner distributors
15 manufacturing plants and logistic hubs

● sales offices
 ● manufacturing plants and logistic hubs



LATEST INNOVATIONS

2010 **Creation Clic System:** unique vertical clic system

2011 **Mipolam Symbioz™:** T Group homogeneous flooring with 100% bio based plasticizer
Evercare™: micro structured, cross coat polymerised, laser technology surface treatment

2012 **Taraflex™ Dry Tex System:** unique & patented solution for moisture subfloor

2013 **New Mural Calypso**

2014 **New Taralay Premium with Protecso® 2 surface treatment**

2015 **Clean Corner System:** unique and patented installation solution

GTI EL5: unique and patented ESD renovation tile

2016 **Creation** collection awarded reddot award winner 2016



2017 **New Taralay Impression** collection awarded IDA 2017



Mipolam "80 years": new Mipolam Affinity, Accord, Classic, Cosmo

ECO-RESPONSIBLE SOLUTIONS

LESS SPEAKING FOR MORE ACTION



INDOOR AIR QUALITY



COMPOSITION

- **100% REACH** compliant
- **FREE** of formaldehyde
- **FREE** of heavy metals
- **FREE** of solvent



INSTALLATION

- **Innovative adhesive free installation systems**



RECYCLED CONTENT

- **25%** average recycled content
- **100% REACH compliant** recycled content



RECYCLING

- **100%** recyclable product



LIFE CYCLE ANALYSIS

- **Eco-designed** according to a product specific Life Cycle Analysis
- **Product specific EPD** (Environmental Products Declaration) available
- **Manufactured in an ISO 14001 and ISO 50001** certified site
- **Contribution to many Green Building Schemes** (LEED, HQE, BREEAM...)
- **Exclusive surface treatments** to reduce drastically the use of chemical product and water and ensure the lowest environmental impact



INDOOR AIR QUALITY

- **TVOC emissions 10 times better than norms requirements** (TVOC < 100 µg/m³ after 28 days)
- **TVOC < 10ug/m³ after 28 days** for all products treated Evercare™ / Protocolsol®2
- **Floorscore certified**
- **M1 certified**
- **Comply with AgBB protocol**
- **No formaldehyde emission**



WELLNESS

- **Health:** Antibacterial activity (inhibits growth > 99%)
- **Safety:** Anti slip performance
- **Comfort:** Walking comfort and impact noise reduction

CONTRIBUTION TO GREEN BUILDING CERTIFICATION



**100%
RECYCLABLE**



LEED (Leadership in Energy and Environmental Design) certification

issued by the USGBC (US Green Building Council), confirms that a building or a community has been designed and constructed using strategies to improve performance by saving energy, treating water, reducing CO₂ emissions, and improving indoor air quality. Our floorings contribute to building certifications (3 levels of certification: silver, gold, platinum) because:

- Low VOC emission (Floorscore® compliant)
- High recycled content
- Product specific EPD (Environment Product Declaration)



Leed Gold Certified

Oak Park Sport Center
USA

Sofia Airport Center
BULGARIA



Leed Platinum Certified

Kaust University
SAUDI ARABIA



2013 Greenest School on Earth

Sin Ying School
HONG-KONG



4 Star As-Built Rating

Mastercards Offices
AUSTRALIA



Office Insider

.....

HOMOGENEOUS
FLOORING

..... PAGES

8 / 35

.....



Homogeneous flooring Evercare™

- Mipolam Symbioz™ 14
- Mipolam Esprit 20
- Mipolam Affinity **NEW** 22
- Mipolam Accord **NEW** 24
- Mipolam Elegance 26
- Mipolam Cosmo **NEW** 28
- Mipolam Troplan 30

Homogeneous flooring (PUR)

- Mipolam Classic **NEW** 34

Homogeneous flooring (PU)

- Architecton 35

HOMOGENEOUS FLOORING

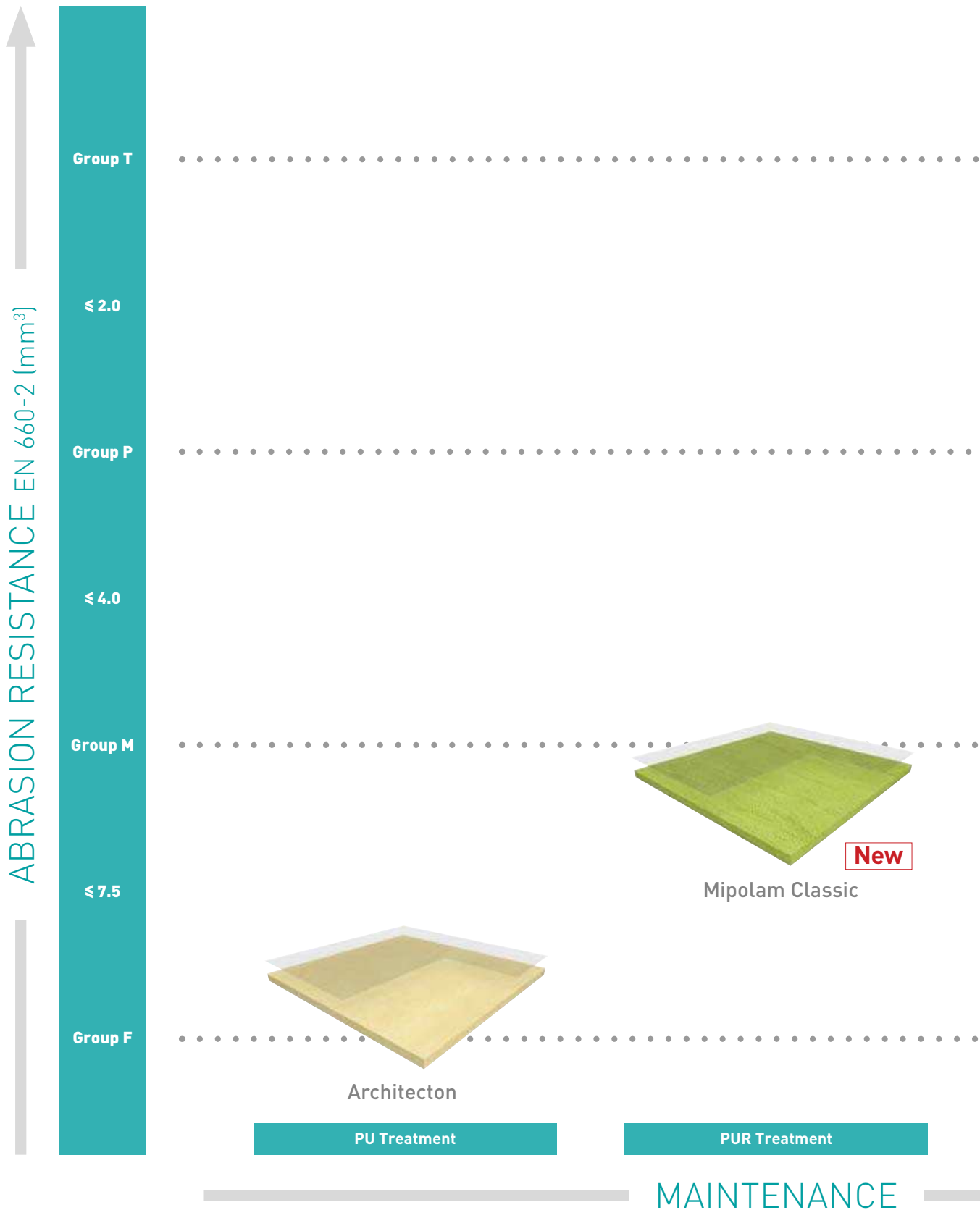



Mipolam Esprit
Mipolam Affinity **New**
Mipolam Accord **New**
Mipolam Elegance



Mipolam Symbioz™



New
Mipolam Cosmo

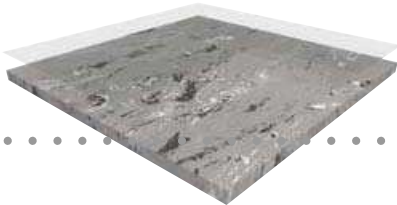

Mipolam Troplan

Evercare™ Treatment

HOMOGENEOUS FLOORING

MIPOLAM SYMBIOZ™

▶ MIPOLAM SYMBIOZ™

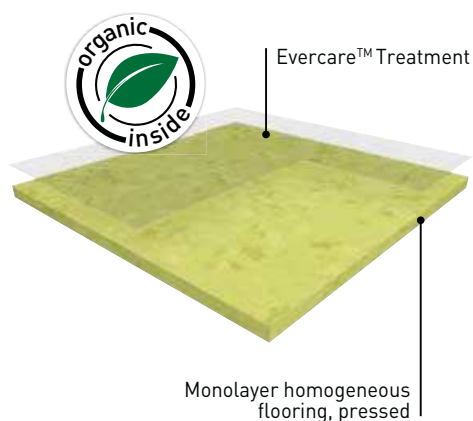

MIPOLAM SYMBIOZ™ is a fully flexible homogeneous compacted floorcovering in sheet, 2m wide, abrasion group T, providing excellent resistance to wear and tear in high traffic areas. Its weight is **2580 gr/m²**. It features a non-directional design incorporating coloured chips to ensure an even colour throughout the thickness presenting a **nice matt finish**.

MIPOLAM SYMBIOZ™ contains over 75% sustainable or renewable raw materials. It includes a 100% bio based plasticizer, made of residues from cereals (wheat, corn...). This floorcovering is a non-emissive product (below the level of VOC measurement accuracy).

The flooring is equipped with **Evercare™**, patented surface treatment obtained by UV laser cross-linking offering **the best chemical resistance to the main products used in healthcare** environment as Betadine, eosin, hydro alcoholic solutions, making the maintenance easy and long lasting the flooring. This treatment **avoids applying any acrylic emulsion** throughout the lifetime of the product.

The flooring is **antistatic** (<2kV), its residual indentation is ≈ 0.02 mm. The flooring is a **group T** wear rating suitable for heavy duty traffic areas and **B_{fl-s1}** fire resistance.

As part of our sustainable development policy, this product is manufactured in the first floor covering plant awarded with the triple certification: ISO 9001 (quality), ISO 14 001 (environment) and OHSaS 18001 (safety).



BBR40 :
100% Bio-based plasticizer rod for Mipolam Symbioz™
(see page 285)

MIPOLAM SYMBIOZ™



T

Evercare™



100% recyclable

Mipolam Symbioz™ has been engineered using a full life cycle model, to guarantee the lowest environmental impact at every stage of the product life

- ▶ **Highest durability:** abrasion T group: product life expectancy > 20 years
- ▶ **Eco-responsible exclusive Bio based plasticizer, 100% made from organic source**
- ▶ **Evercare™** : New revolutionary patented polyurethane surface treatment with unique performance in staining providing chemical resistance
- ▶ **Easy maintenance:** no wax for life
- ▶ **On average 30% savings on maintenance cost**
- ▶ **15% less detergent and water use.**

Indoor Air Quality: very low emitting material (40 times lower than European standards).

MIPOLAM SYMBIOZ™

| DESCRIPTION | | | |
|------------------------------------------------------------------------|-------------------------|---------------------|--------------------------|
| Total thickness | EN ISO 24346 (EN 428) | mm | 2 |
| Weight | EN ISO 23997 (EN 430) | g/sq.m | 2580 |
| Width of sheet | EN ISO 24341 (EN 426) | cm | 200 |
| Length of sheet | EN ISO 24341 (EN 426) | lm | 20 |
| CLASSIFICATION | | | |
| Norm / Product specification | - | - | EN ISO 10581 (EN 649) |
| European classification | EN ISO 10874 (EN 685) | class | 34-43 |
| Fire rating | EN 13501-1 | class | B _{fl} -s1 |
| Static electrical propensity | EN 1815 | kV | < 2 |
| Slip resistance ⁽¹⁾ | DIN 51130 | class | R9 |
| PERFORMANCES | | | |
| Wear resistance | EN 660.2 | mm ³ | ≤ 2.0 |
| Wear group | NF 189 | group | T |
| Type Binder content | EN ISO 10581 | type | I |
| Dimensional stability | EN ISO 23999 (EN 434) | % | ≤ 0.40 |
| Impact Sound Insulation | EN ISO 717-2 | dB | 5 |
| Residual indentation | EN ISO 24343-1 (EN 433) | mm | ≈ 0.02 |
| Castor chair test (type W) | ISO 4918 (EN 425) | - | OK |
| Thermal conductivity | EN ISO 10456 (EN 12524) | W/(m.k) | 0.25 |
| Colour fastness | EN 20 105 - B02 | degree | ≥ 6 |
| Surface treatment | - | - | EVERCARE™ |
| Chemical products resistance | EN ISO 26987 (EN 423) | class | OK |
| Anti-bacterial activity [E. coli - S. aureus - MRSA] ⁽²⁾ | ISO 22196 | - | > 99% inhibits growth |
| ENVIRONMENT / INDOOR AIR QUALITY | | | |
| TVOC after 28 days | ISO 16000-6 | µg / m ³ | <10 |
| Certification | - | - | Floorscore® |
| CE MARKING | | | |
| CE | EN 14041 | | |
| | | | |

(1) For lifetime sustainable wet resistance, please refer to Tarasafe ranges.

(2) The implementation of an effective cleaning regime is the most important defence against infection.

HOMOGENEOUS FLOORING

MIPOLAM SYMBIOZ™



T

Evercare™

100% recyclable



6027 Acacia



6048 Lavander



6007 Garden



6006 Blue Sky



6055 Tomato



6017 Grass

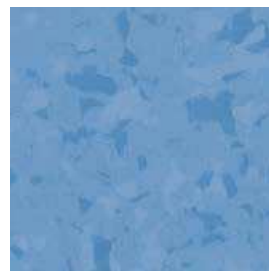

6016 Sea Blue



6035 Sunset



6037 Lagoon



6046 Blue Night



6032 Sunshine



MIPOLAM SYMBIOZ™



T

Evercare™



100% recyclable



6029 Cloud

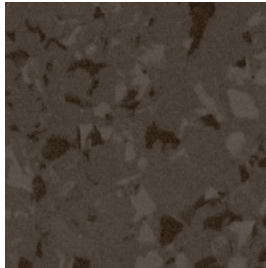

6045 Chocolate



6034 Mole

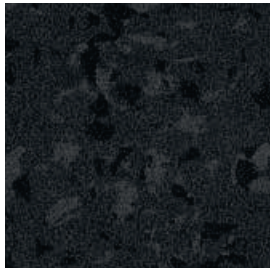

6059 Black Diamond



6010 Mist



6043 Wood



6004 Sandstone



6044 Sea Storm



6009 Grey Stone



6041 Clay



6003 Linen



6039 Pebble



6008 Calico



6031 Breeze

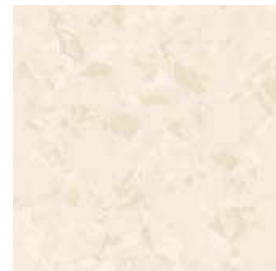

6001 Cotton



HOMOGENEOUS FLOORING

MIPOLAM ESPRIT / AFFINITY / ACCORD / ELEGANCE / COSMO / TROPLAN

▶ MIPOLAM ESPRIT

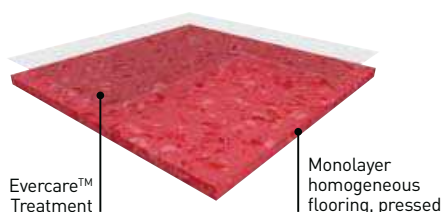

MIPOLAM ESPRIT is a vinyl flooring homogeneous pressed in 2m sheets, with a thickness of 2mm and a **weight ≤ 2780 g**. The non-directional design with colour throughout the thickness is available in 24 references presenting a nice **matt finish**. This flooring is suitable for heavy duty traffic areas, and facilitates floor-wall junctions, angles and welding treatments. The flooring is equipped with **Evercare™**, a patented surface treatment obtained by UV laser cross-linking offering the best chemical resistance to the main products used in healthcare environment as Betadine, eosin, hydro alcoholic solutions, making the maintenance easy and long lasting the flooring. This treatment avoids applying any acrylic emulsion throughout the lifetime of the product. This flooring is composed of 45% minerals, 22% of inexhaustible material and at least 25% of recycled 100% controlled. It is free of formaldehyde, heavy metals and CMR 1 & 2 or vPvB (very persistent and very bio accumulative) or PBT (persistent, bio-accumulative and toxic) and is **REACH compliant**. COV emissions after 28 days (ISO 16000-6) are below detection levels with $<10 \mu\text{g}/\text{m}^3$ and this product is classified A + (the best class). On demand, **MIPOLAM ESPRIT** is available with phthalate free. The flooring is **antistatic** ($<2\text{kV}$), its residual indentation is $\leq 0.02 \text{ mm}$. The flooring is a **group T** wear rating suitable for heavy duty traffic areas and **Bfl-s1** fire resistance.

▶ MIPOLAM AFFINITY

NEW

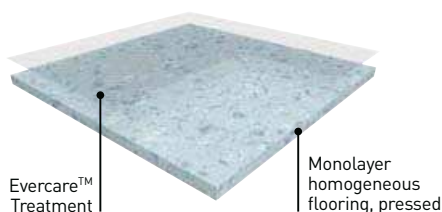

MIPOLAM AFFINITY is a vinyl flooring homogeneous pressed in 2m sheets, with a thickness of 2mm and a **weight of 2850g**. The non-directional design with colour throughout the thickness is available in 28 references presenting a contrasted designed & a **matt finish**.

This flooring is recommended for collective buildings making skirtings easier, as well as angles and welding. The flooring is equipped with **Evercare™**, patented surface treatment obtained by UV laser cross-linking offering the best chemical resistance to the main products used in healthcare environment as betadine, eosin, hydro alcoholic solutions, making the maintenance easy and the floor long lasting. This treatment avoids applying any acrylic emulsion throughout the lifetime of the product.

It is free of formaldehyde, heavy metals and CMR 1 & 2 or vPvB (very persistent and very bio accumulative) or PBT (persistent, bio-accumulative and toxic) and is **REACH compliant**. Its VOC emissions after 28 days (ISO 16000-6) are below detection levels ($<10 \mu\text{g} / \text{m}^3$) and this product is classified A + (the best class). On demand, **MIPOLAM AFFINITY** is available with phthalate free plasticizer. This flooring is **antistatic** ($<2\text{kV}$), its residual indentation is $\leq 0.02 \text{ mm}$ to 150 minutes respecting EN ISO 24343-1 (EN 433). This flooring complies with EN ISO 10581 (EN 649) offering a **group T** wear rating and complies with EN ISO 10581 offering a Binder content Type I, which makes it suitable for heavy duty traffic areas. It has a **Bfl-s1** fire resistance.

▶ MIPOLAM ACCORD

NEW

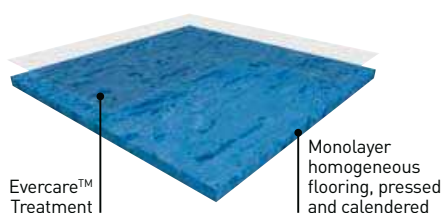

MIPOLAM ACCORD is a monolayer homogeneous flooring with high PVC content calendered and pressed in 2m sheets, with a thickness of 2mm and a **weight of ≤ 2850g**. The semi-directional design with colour throughout the thickness is available in 28 references presenting a nice **matt finish**. This flooring is recommended for collective buildings making skirtings easier, as well as angles and welding. The flooring is equipped with **Evercare™** the latest improvements in polyurethane surface treatment obtained by UV laser cross-linking. This **Evercare™** treatment avoids staining of chemical products used in Healthcare like betadine, eosin or anti-bacterial hand gel and increases the durability of the flooring. This treatment has excellent maintenance characteristics and does not require the application of acrylic polishes. The flooring is composed of minimum 25% recycled content 100% controlled and is **REACH compliant**. This flooring is **antistatic** ($<2\text{kV}$). The product is non reactive to residual indentation with a value $\leq 0,02 \text{ mm}$. The flooring is a **group T** wear rating suitable for heavy duty traffic areas and **Bfl-s1** fire resistance. The product emission rate of volatile organic compounds is $<10 \mu\text{g}/\text{m}^3$ (TVOC after 28 days ISO 16000-6).

MIPOLAM ESPRIT / AFFINITY / ACCORD / ELEGANCE / COSMO / TROPLAN

▶ MIPOLAM ELEGANCE

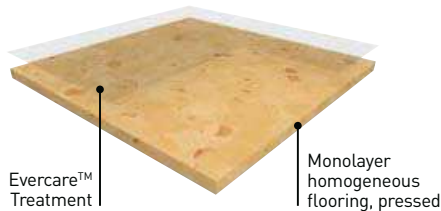

MIPOLAM ELEGANCE is a monolayer homogeneous flooring with a high PVC content pressed in 2m sheets, with a thickness of 2mm and a **weight of $\leq 2850g$** . The non-directional design with colour throughout the thickness integrates a 3D effect (transparent particles in pure PVC on all 33 references) and a **mat finish**. This flooring is recommended for administrative buildings making skirtings easier, as well as angles and welding. The flooring is equipped with **Evercare™** the latest improvements in polyurethane surface treatment obtained by UV laser cross-linking. This Evercare™ treatment avoids staining of chemical products used in Healthcare like betadine, eosin or anti-bacterial hand gel and increases the durability of the flooring. This treatment has excellent maintenance characteristics and does not require the application of acrylic polishes. The flooring is composed of minimum 25% recycled content 100% controlled and is **REACH compliant**. This flooring is **antistatic** ($<2kV$). The product is non reactive to residual indentation with a value $\leq 0,02$ mm. The flooring is a **group T** wear rating suitable for heavy duty traffic areas and **Bfl-s1** fire resistance. The product emission rate of volatile organic compounds is $<10 \mu g/m^3$ (TVOC after 28 days ISO 16000-6).

▶ MIPOLAM COSMO

NEW

MIPOLAM COSMO is a vinyl flooring homogeneous calendered and pressed in 2m sheets, with a thickness of 2mm and a **weight $\leq 3000g$** . The semi-directional design with colour throughout the thickness is available in 24 references presenting a nice **mat finish**. This flooring is suitable for medium to high traffic areas, and facilitates floor-wall junctions, angles and welding treatments. The flooring is equipped with **Evercare™**, a patented surface treatment obtained by UV laser cross-linking offering the best chemical resistance to the main products used in healthcare environment as Betadine, eosin, hydro alcoholic solutions, making the maintenance easy and long lasting the flooring. This treatment avoids applying any acrylic emulsion throughout the lifetime of the product. This flooring is composed of 45% minerals, 22% of inexhaustible material and at least 25% of recycled 100% controlled. It is free of formaldehyde, heavy metals and CMR 1 & 2 or vPvB (very persistent and very bio accumulative) or PBT (persistent, bio-accumulative and toxic) and is **REACH compliant**. COV emissions after 28 days (ISO 16000-6) are below detection levels with $<10 \mu g/m^3$ and this product is classified A+ (the best class). On demand, **MIPOLAM COSMO** is available with phthalate free. The flooring is **antistatic** ($<2kV$), its residual indentation is ≤ 0.02 mm. The flooring is a **group P** wear rating suitable for heavy duty traffic areas and **Bfl-s1** fire resistance.

▶ MIPOLAM TROPLAN

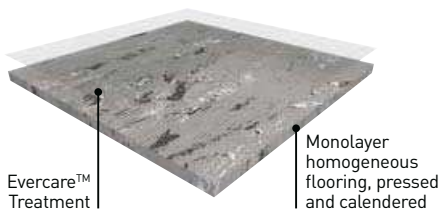

MIPOLAM TROPLAN is a vinyl flooring homogeneous calendered and pressed in 2m sheets, with a thickness of 2mm and a **weight $\leq 3300g$** . The directional design with colour throughout the thickness is available in 18 references presenting a nice **mat finish**. This flooring is suitable for medium to high traffic areas, and facilitates floor-wall junctions, angles and welding treatments. The flooring is equipped with **Evercare™**, patented surface treatment obtained by UV laser cross-linking offering the best chemical resistance to the main products used in healthcare environment as Betadine, eosin, hydro alcoholic solutions, making the maintenance easy and long lasting the flooring. This treatment avoids applying any acrylic emulsion throughout the lifetime of the product. This flooring is composed of 45% minerals, 22% of inexhaustible material and at least 25% of recycled 100% controlled. It is free of formaldehyde, heavy metals and CMR 1 & 2 or vPvB (very persistent and very bio accumulative) or PBT (persistent, bio-accumulative and toxic) and is **REACH compliant**. COV emissions after 28 days (ISO 16000-6) are below detection levels with $<10 \mu g/m^3$ and this product is classified A+ (the best class). On demand, **MIPOLAM COSMO** is available with phthalate free. The flooring is **antistatic** ($<2kV$), its residual indentation is ≤ 0.03 mm. The flooring is a **group M** wear rating suitable for heavy duty traffic areas and **Bfl-s1** fire resistance.



HOMOGENEOUS FLOORING

MIPOLAM ESPRIT / AFFINITY / ACCORD / ELEGANCE / COSMO / TROPLAN



Evercare™



High performing homogeneous multipurpose floorings

Suitable for heavy traffic areas (education, healthcare, shops)

► MIPOLAM ESPRIT / MIPOLAM AFFINITY / MIPOLAM ACCORD / MIPOLAM ELEGANCE / MIPOLAM COSMO / MIPOLAM TROPLAN:

Evercare™ - New revolutionary patented polyurethane surface treatment with unique performance in staining providing unrivalled chemical and scratching resistance

► Antistatic

► Densely compacted surface for improved wear and ease of maintenance.

| | | | MIPOLAM ESPRIT | MIPOLAM AFFINITY | MIPOLAM ACCORD | MIPOLAM ELEGANCE | MIPOLAM COSMO | MIPOLAM TROPLAN |
|---------------------------------------------------------------------|-------------------------|---------------------|-----------------------------|-----------------------------|-----------------------------|-----------------------------|-----------------------------|-----------------------------|
| DESCRIPTION | | | | | | | | |
| Total thickness | EN ISO 24346 [EN 428] | mm | 2 | 2 | 2 | 2 | 2 | 2 |
| Weight | EN ISO 23997 [EN 430] | g/sq.m | 2780 | 2850 | 2850 | 2850 | 3000 | 3300 |
| Width of sheet | EN ISO 24341 [EN 426] | cm | 200 | 200 | 200 | 200 | 200 | 200 |
| Length of sheet | EN ISO 24341 [EN 426] | lm | 20 | 20 | 20 | 20 | 20 | 20 |
| Tile size | EN ISO 24342 [EN 427] | mm | 608 x 608 ⁽¹⁾ | 608 x 608 ⁽¹⁾ | 608 x 608 ⁽¹⁾ | 608 x 608 ⁽¹⁾ | 608 x 608 ⁽¹⁾ | 608 x 608 ⁽¹⁾ |
| Number of tiles per package | - | - | 20 | 20 | 20 | 20 | 20 | 20 |
| CLASSIFICATION | | | | | | | | |
| Norm / Product specification | - | - | EN ISO 10581 [EN 649] | EN ISO 10581 [EN 649] | EN ISO 10581 [EN 649] | EN ISO 10581 [EN 649] | EN ISO 10581 [EN 649] | EN ISO 10581 [EN 649] |
| European classification | EN ISO 10874 [EN 685] | class | 34-43 | 34-43 | 34-43 | 34-43 | 34-43 | 34-43 |
| Fire rating | EN 13501-1 | class | B _{fl} -s1 | B _{fl} -s1 | B _{fl} -s1 | B _{fl} -s1 | B _{fl} -s1 | B _{fl} -s1 |
| Static electrical propensity | EN 1815 | kV | < 2 | < 2 | < 2 | < 2 | < 2 | < 2 |
| Slip resistance ⁽²⁾ | DIN 51130 | class | R9 | R9 | R9 | R9 | R9 | R9 |
| PERFORMANCES | | | | | | | | |
| Wear resistance | EN 660.2 | mm ³ | ≤ 2.0 | ≤ 2.0 | ≤ 2.0 | ≤ 2.0 | ≤ 4.0 | ≤ 7.5 |
| Wear group | NF 189 | group | T | T | T | T | P | M |
| Type Binder content | EN ISO 10581 | type | I | I | I | I | I | II |
| Dimensional stability | EN ISO 23999 [EN 434] | % | Sheet ≤ 0.40 Tile ≤ 0.25 | Sheet ≤ 0.40 Tile ≤ 0.25 | Sheet ≤ 0.40 Tile ≤ 0.25 | Sheet ≤ 0.40 Tile ≤ 0.25 | Sheet ≤ 0.40 Tile ≤ 0.25 | Sheet ≤ 0.40 Tile ≤ 0.25 |
| Impact Sound Insulation | EN ISO 717-2 | dB | 5 | 5 | 5 | 5 | 5 | 4 |
| Residual indentation | EN ISO 24343-1 [EN 433] | mm | ≈ 0.02 | ≈ 0.02 | ≈ 0.02 | ≈ 0.02 | ≈ 0.02 | ≈ 0.03 |
| Castor chair test (type W) | ISO 4918 [EN 425] | - | OK | OK | OK | OK | OK | OK |
| Thermal conductivity | EN ISO 10456 [EN 12524] | W/(m.k) | 0.25 | 0.25 | 0.25 | 0.25 | 0.25 | 0.25 |
| Colour fastness | EN 20 105 - B02 | degree | ≥ 6 | ≥ 6 | ≥ 6 | ≥ 6 | ≥ 6 | ≥ 6 |
| Surface treatment | - | - | Evercare™ | Evercare™ | Evercare™ | Evercare™ | Evercare™ | Evercare™ |
| Chemical products resistance | EN ISO 26987 [EN 423] | class | OK | OK | OK | OK | OK | OK |
| Anti-bacterial activity (E. coli - S. aureus - MRSA) ⁽³⁾ | ISO 22196 | - | > 99% inhibits growth | > 99% inhibits growth | > 99% inhibits growth | > 99% inhibits growth | > 99% inhibits growth | > 99% inhibits growth |
| ENVIRONMENT / INDOOR AIR QUALITY | | | | | | | | |
| TVOC after 28 days | ISO 16000-6 | µg / m ³ | <10 | <10 | <10 | <10 | <10 | <10 |
| Certification | - | - | Floorscore® | Floorscore® | Floorscore® | Floorscore® | Floorscore® | Floorscore® |
| CE MARKING | | | | | | | | |
| | | | EN 14041 | | | | | |

(1) Products available in tiles for a minimum quantity order of 500 sqm.

(2) For lifetime sustainable wet resistance, please refer to Tarasafe ranges.

(3) The implementation of an effective cleaning regime is the most important defence against infection.

HOMOGENEOUS FLOORING



5341 Peanut



5340 Mist



5329 Cumin

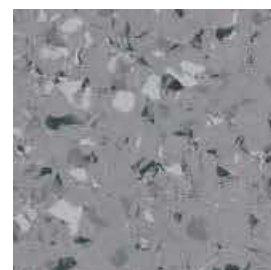

5330 Smoke

MIPOLAM ESPRIT



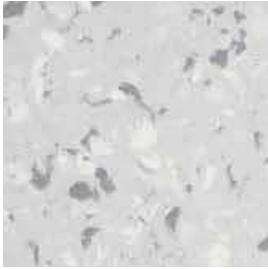

Evercare™
 100% recyclable

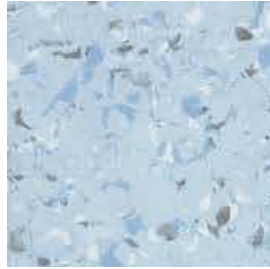

5312 White Pepper

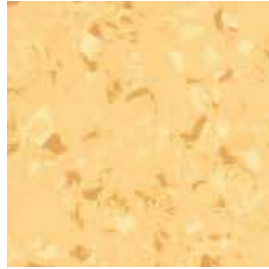

5306 Mixblue



5332 Turmeric



5305 Garlic

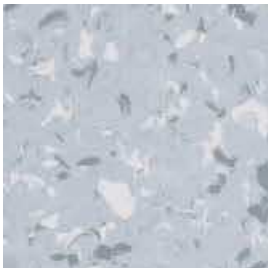

5310 Mixdim



5366 Iris



5385 Safran

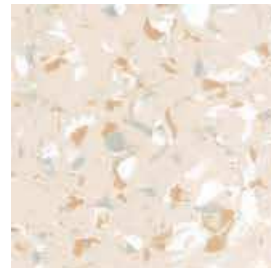

5303 Mixbeige

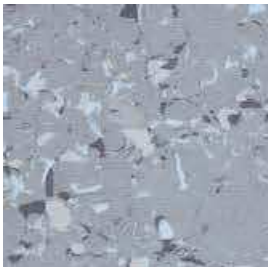

5320 Mixgrey

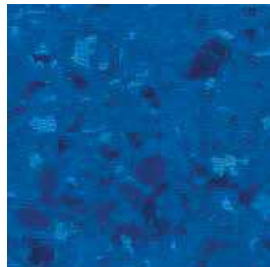

5356 Indigo



5322 Zest



5324 Sesame

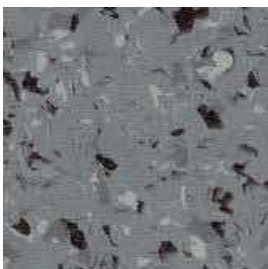

5350 Slate

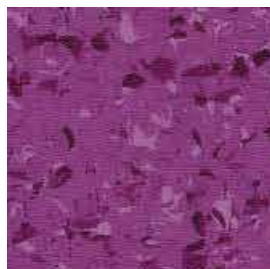

5368 Lavande

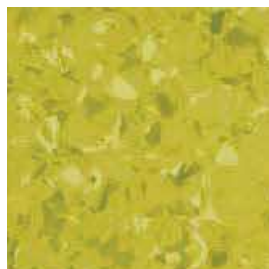

5357 Chervil



5354 Coriander



5360 Mixdark



5375 Paprika



5347 Cardamon



5363 Cinnamon

◆ Tiles (608 x 608 mm) available for a minimum order quantity of 500 sqm.

HOMOGENEOUS FLOORING

MIPOLAM AFFINITY **NEW**



Compact Compact T Evercare™ 100% recyclable

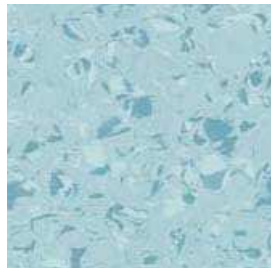

4417 Aquamarine

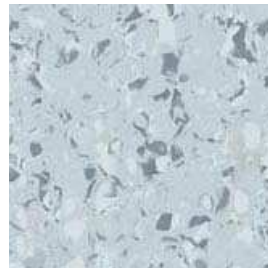

4410 Violet Grey

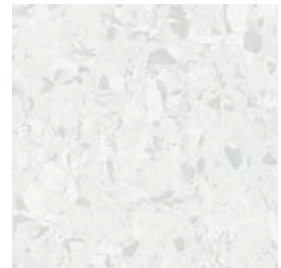

4408 Crystal Ice

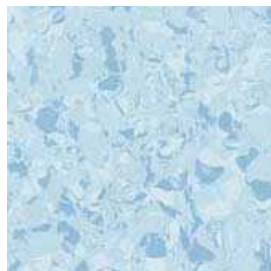

4496 Light Sapphire



4420 Silver Grey



4409 Matte Grey

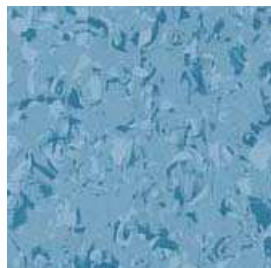

4416 Sapphire

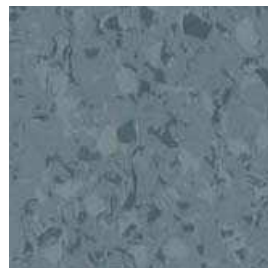

4450 Stormy Weather

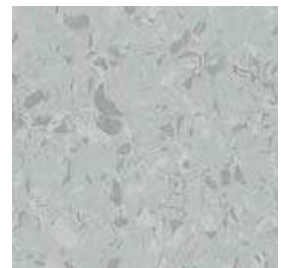

4429 Gray Opal

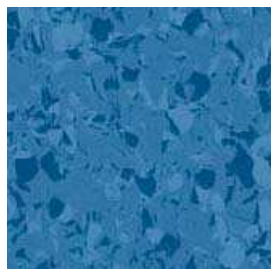

4446 Blue Ocean

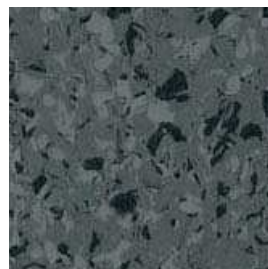

4459 Grey Storm

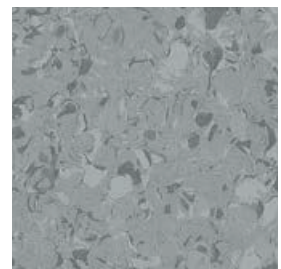

4430 Pearl Grey

◆ Tiles (608 x 608 mm) available for a minimum order quantity of 500 sqm.

MIPOLAM AFFINITY NEW





T
Evercare™
 100% recyclable



4405 Sand Opal



4403 Natural Shade



4447 Light Emerald



4432 Citrine



4401 Quartz



4441 Light Greige

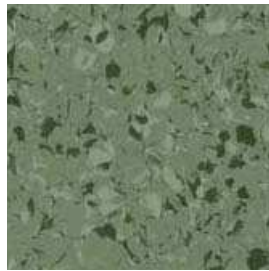

4457 Olivine



4455 Orange Sunlight



4424 Smoked Opal



4445 Mocca



4443 Lime Taupe



4448 Ruby



4425 Amber



4460 Black Stone



4463 Greige

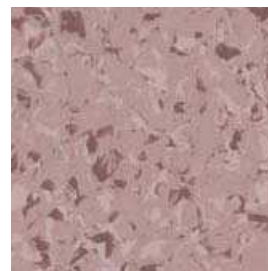

4437 Cashmere Rose

◆ Tiles (608 x 608 mm) available for a minimum order quantity of 500 sqm.

HOMOGENEOUS FLOORING

MIPOLAM ACCORD **NEW**



0425 Cork



0324 Sand

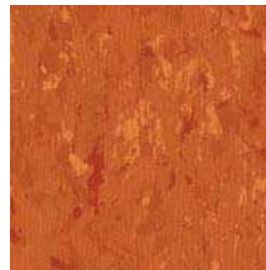

0315 Orange River



0332 Dore



0448 Bandak



0447 Grunsee

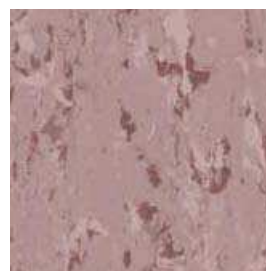

0437 Flamingo Resort

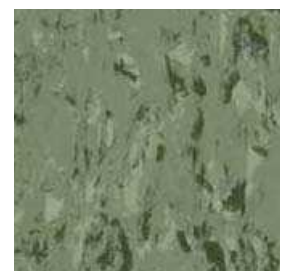

0457 Como

MIPOLAM ACCORD NEW



Evercare™
 100% recyclable



0301 Louise

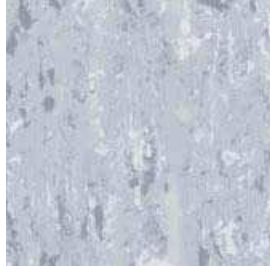

0310 Huron



0312 Powell



0321 Salt



0303 Manitoba



0320 Ontario

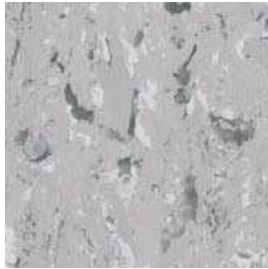

0319 Toba

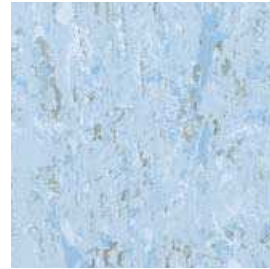

0306 Inari



0305 Light Sand

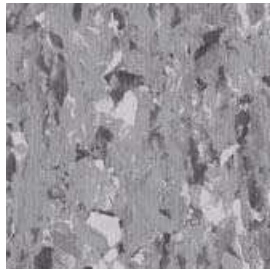

0330 Kruger



0450 Thames

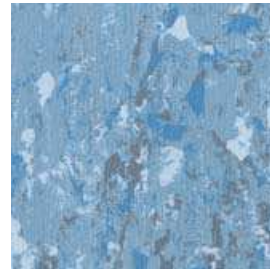

0316 Malaren



0441 Loch Ness



0443 Krumme



0459 Mississippi

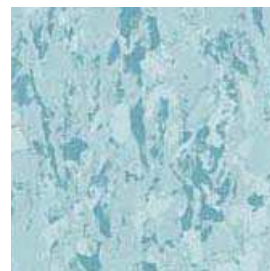

0417 Constance



0463 Bourget



0445 Otto

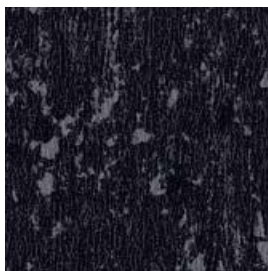

0360 Balaton

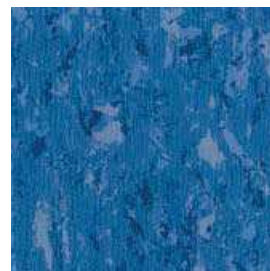

0346 Roxen

◆ Tiles (608 x 608 mm) available for a minimum order quantity of 500 sqm.

HOMOGENEOUS FLOORING

MIPOLAM ELEGANCE



Compact Compact Compact T Evercare™ 100% recyclable



0323 Nut

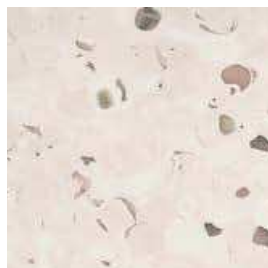

0347 Mangoustan



0705 Patisson



0697 Greenstone

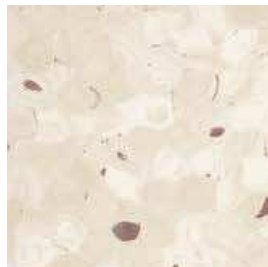

0322 Jicama

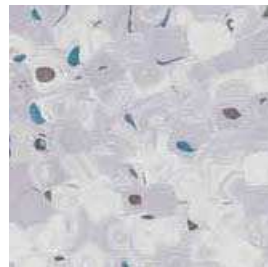

0318 Grape

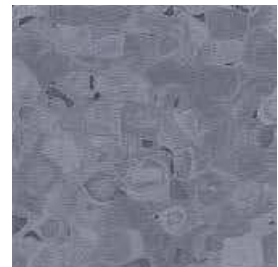

0704 Raspberry Grey



0328 Almond



0696 Ginger



0344 Nutmeg



0327 Pear



0343 Pecan



0321 Olive

◆ Tiles (608 x 608 mm) available for a minimum order quantity of 500 sqm.

MIPOLAM ELEGANCE

 Compact
  Compact
  Compact
  T
  Evercare™
  100% recyclable

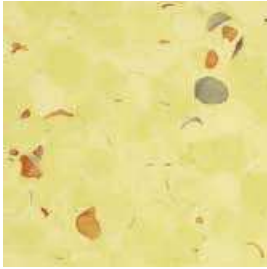

0703 Lime

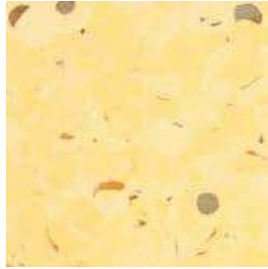

0699 Banana

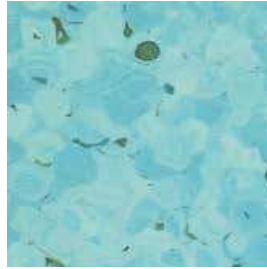

0340 Jambolan

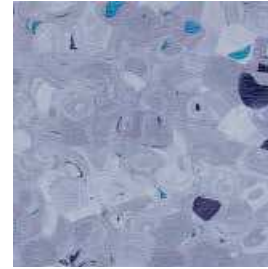

0319 Quetsche



0329 Hazelnut



0333 Ananas

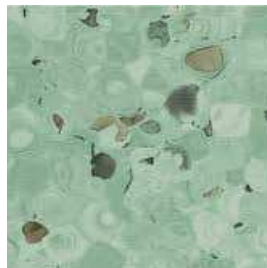

0339 Apple

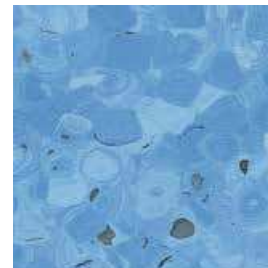

0348 Bluetta



0324 Chestnut

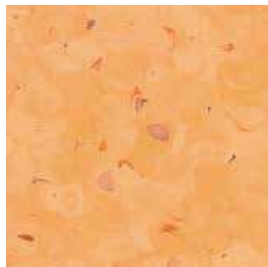

0700 Melon



0338 Kiwi



0341 Bilberry

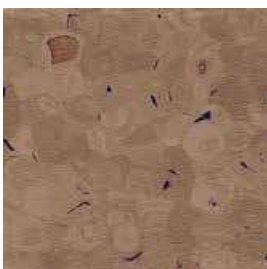

0698 Cacao



0702 Kumquat

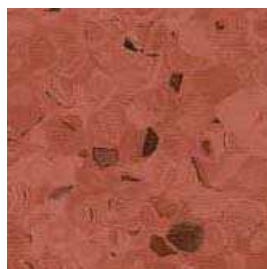

0330 Litchi



0342 Blueberry



0326 Jojoba



0331 Plum

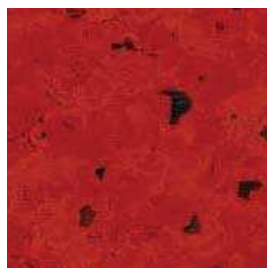

0336 Acerola



0349 Bluecrop

 References also available as Elegance SD suitable for Shower system.

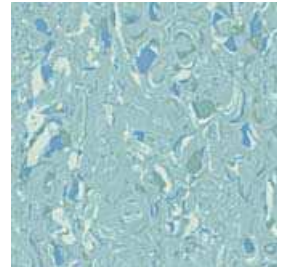

2607 Aqua Marine

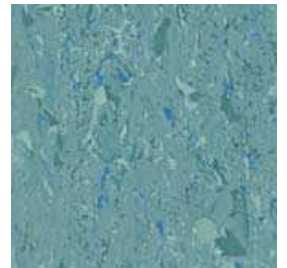

2637 Emerald

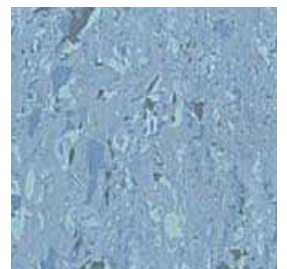

2606 Azur

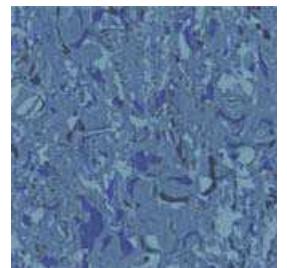

2636 Overseas

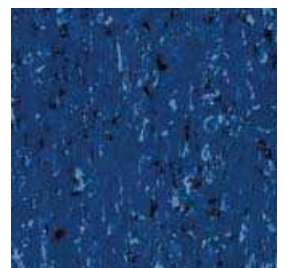

2646 Blue Navy

HOMOGENEOUS FLOORING

MIPOLAM COSMO **NEW**



P | Evercare™ |  100% recyclable

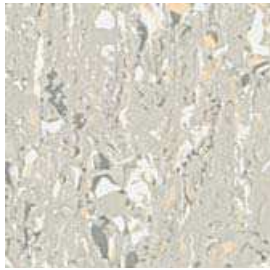

2609 Light Smoke

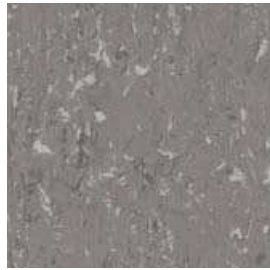

2638 Pure Grey

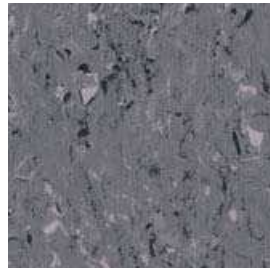

2639 Smart Grey

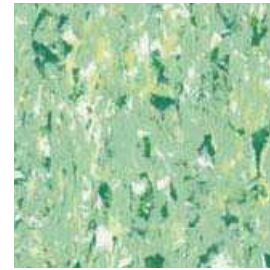

2317 Soft Green

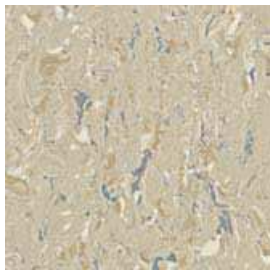

2633 Lichen

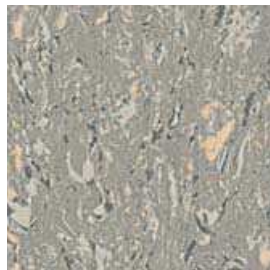

2610 Silver

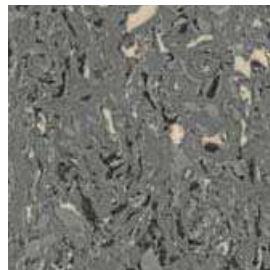

2659 Warm Grey



2337 Green Forest



2603 Lemon Chiffon



2634 Caramel Cream

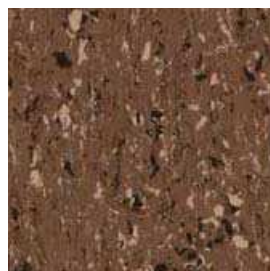

2645 Macchiato

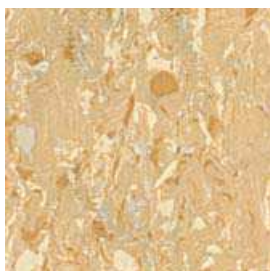

2604 Wheat

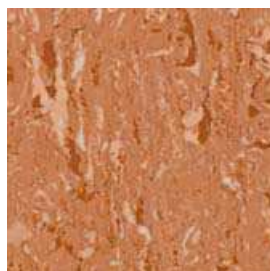

2655 Tangerine

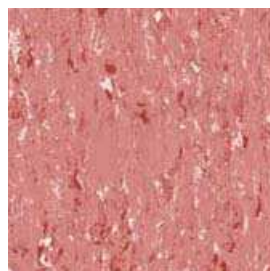

2648 Rosa Antico

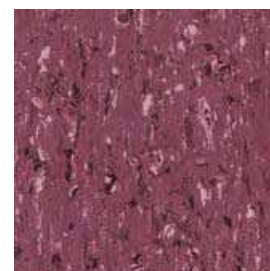

2628 Purple Rain



2635 Peach Orange



2325 Ochre



2632 Limoncello



2355 Real Red

*  (608 x 608 mm) compact tile in stock. All other references available as tiles for a minimum order quantity of 500 sqm.

HOMOGENEOUS FLOORING

MIPOLAM TROPLAN

Compact Compact M Evercare™ 100% recyclable



1032 Yellow



1055 Apricot



1010 Grey



1009 Light Grey



1002 Beige



1003 Light Ocre



1059 Blue Grey



1006 Blue



1007 Green



1035 Ocre



1040 Dark Grey

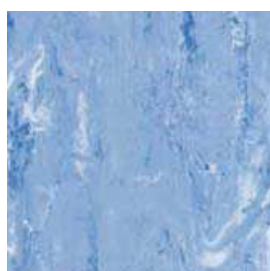

1036 Medium Blue

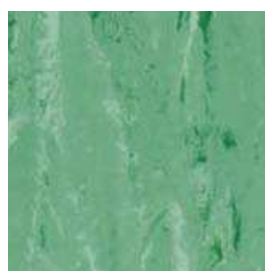

1037 Medium Green



1004 Earth



1060 Anthracite

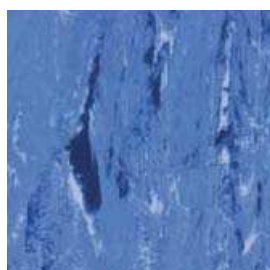

1056 Dark Blue

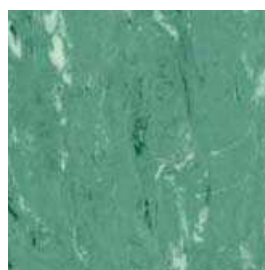

1057 Dark Green



1033 Brown

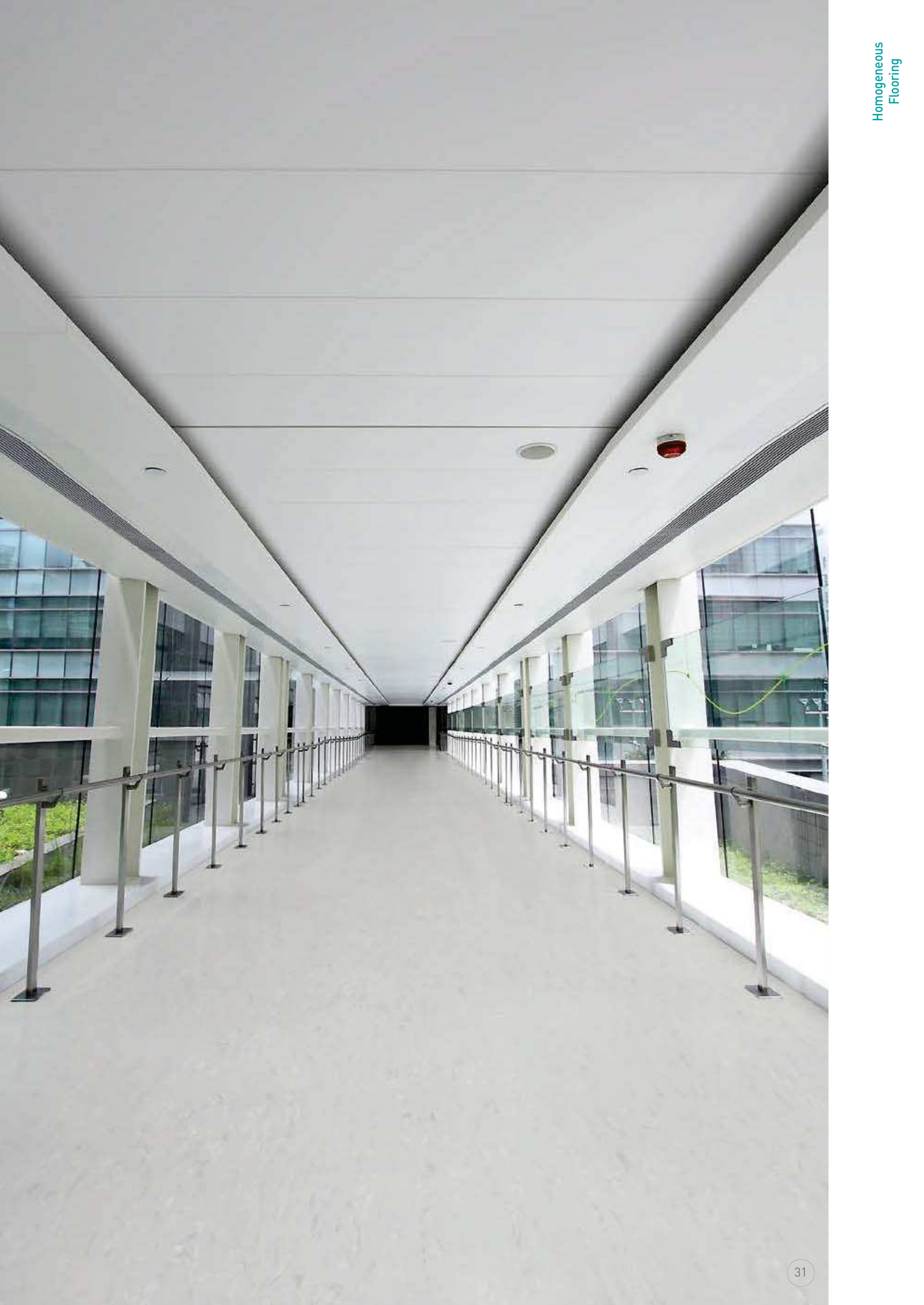

HOMOGENEOUS FLOORING

MIPOLAM CLASSIC - ARCHITECTON

▶ MIPOLAM CLASSIC

NEW

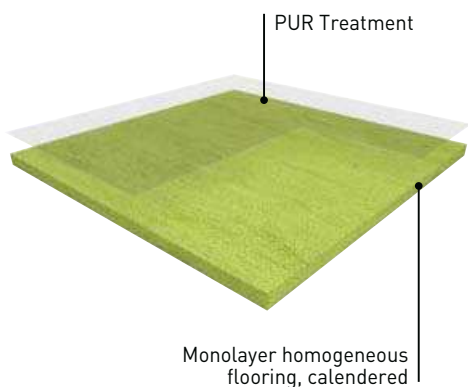

MIPOLAM CLASSIC is a flexible monolayer homogeneous calendered flooring in 2m sheets, with a thickness of 2mm and a **weight of $\leq 3300\text{g}$** .

The directional design with colour throughout the thickness is available in 18 references.

This flooring is antistatic ($<2\text{kV}$).

The product is non reactive to residual indentation with a value $\leq 0.03\text{ mm}$.

This product receives a **PUR** surface treatment : a good foundation for routine maintenance. No acrylic emulsion / polishes is required after installation.

The flooring is **group M** wear rating suitable for medium to heavy traffic areas.

The product emission rate of volatile organic compounds is $<10\ \mu\text{g}/\text{m}^3$ (TVOC after 28 days ISO 16000-6).

▶ ARCHITECTON

 Tiles only

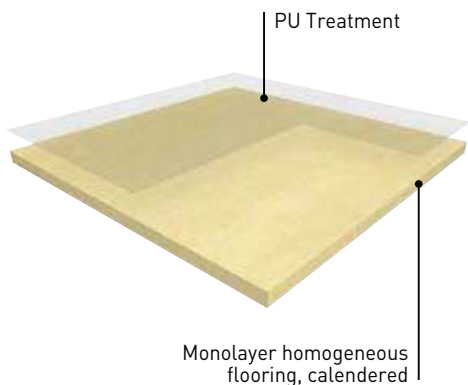

ARCHITECTON is a flexible monolayer homogeneous calendered flooring, with a thickness of 2mm and a **weight of $\leq 3680\text{g}$** .

The directional design with colour throughout the thickness is available in 19 tile references.

This flooring is antistatic ($<2\text{kV}$).

The product is non reactive to residual indentation with a value $\leq 0.03\text{ mm}$.

It receives a protective **PU** factory seal: a good foundation for routine maintenance. Acrylic emulsion / polishes is required after installation.

The flooring is **group F** wear rating suitable for normal to medium traffic areas.

The product emission rate of volatile organic compounds is $<10\ \mu\text{g}/\text{m}^3$ (TVOC after 28 days ISO 16000-6).

MIPOLAM CLASSIC - ARCHITECTON



- ▶ **ARCHITECTON is a homogeneous multipurpose flooring**
- ▶ **MIPOLAM CLASSIC is available in tile or sheet format and is suitable for normal to heavy traffic areas, Group M wear rating**
- ▶ **ARCHITECTON is available in tiles only and is suitable for normal to medium traffic areas, Group F wear rating**
- ▶ **PUR surface treatment: good foundation for routine maintenance.**
- ▶ **PU surface treatment: acrylic emulsion required after installation.**

| | | | MIPOLAM CLASSIC | | ARCHITECTON |
|-----------------------------------------|-------------------------|---------------------|-----------------------|---------------------------------------|-----------------------|
| DESCRIPTION | | | | | |
| Total thickness | EN ISO 24346 [EN 428] | mm | 1.5 | 2 | 2 |
| Weight | EN ISO 23997 [EN 430] | g/sq.m | 2520 | 3300 | 3680 |
| Width of sheet | EN ISO 24341 [EN 426] | cm | 200 | 200 | - |
| Length of sheet | EN ISO 24341 [EN 426] | lm | 20 | 20 | - |
| Tile size | EN ISO 24342 [EN 427] | mm | - | 300 x 300 ⁽¹⁾ 608 x 608 | 300 x 300 |
| Number of tiles per package | - | - | - | 50 / 20 | 50 |
| CLASSIFICATION | | | | | |
| Norm / Product specification | - | - | EN ISO 10581 [EN 649] | EN ISO 10581 [EN 649] | EN ISO 10581 [EN 649] |
| European classification | EN ISO 10874 [EN 685] | class | 23-31 | 34-43 | 33-42 |
| Fire rating | EN 13501-1 | class | Bfl-s1 | Bfl-s1 | Bfl-s1 |
| Static electrical propensity | EN 1815 | kV | < 2 | < 2 | < 2 |
| PERFORMANCES | | | | | |
| Wear resistance | EN 660.2 | mm ³ | ≤ 15.0 | ≤ 7.5 | ≤ 15.0 |
| Wear group | NF 189 | group | F | M | F |
| Type Binder content | EN ISO 10581 | type | II | II | III |
| Dimensional stability | EN ISO 23999 [EN 434] | % | ≤ 0.40 | Sheet ≤ 0.40 Tile ≤ 0.25 | ≤ 0.25 |
| Impact Sound Insulation | EN ISO 717-2 | dB | 4 | 4 | 4 |
| Residual indentation | EN ISO 24343-1 [EN 433] | mm | ≈ 0.03 | ≈ 0.03 | ≈ 0.03 |
| Castor chair test (type W) | ISO 4918 [EN 425] | - | OK | OK | OK |
| Thermal conductivity | EN ISO 10456 [EN 12524] | W/(m.k) | 0.25 | 0.25 | 0.25 |
| Colour fastness | EN 20 105 - B02 | degree | ≥ 6 | ≥ 6 | ≥ 6 |
| Surface treatment | - | - | PUR | PUR | PU |
| Chemical products resistance | EN ISO 26987 [EN 423] | class | OK | OK | OK |
| ENVIRONMENT / INDOOR AIR QUALITY | | | | | |
| TVOC after 28 days | ISO 16000-6 | µg / m ³ | <10 | <10 | <10 |
| CE MARKING | | | | | |
| CE | EN 14041 | | | | |
| | | | | | |

(1) Tiles (300 x 300 mm) available for a minimum order quantity of 500 sqm.

HOMOGENEOUS FLOORING

MIPOLAM CLASSIC NEW

 Compact
  Compact
 M
PUR
 100% recyclable



All colours available as 300 x 300mm tiles upon request for a minimum order quantity of 500 sqm

▲Thickness: 1.5 mm - Sheet format only

ARCHITECTON

Compact | F | PU | 100% recyclable



0092 White



0027 Straw



0055 Summer



0045 Apple

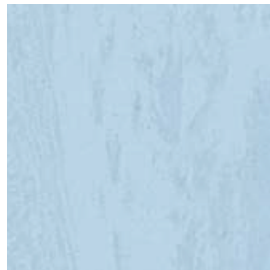

0035 Glacier



0069 Fawn



0043 Muffin



0028 Alp



0085 Marina



0048 Walnut



0065 Clementine



0075 Pigeon



0088 Shadow



0078 Claret



0068 Strawberry



0013 Ash



0098 Storm



0810 Brown

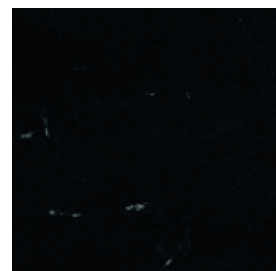

0902 Black



.....

MULTILAYERED FLOORING

..... PAGES

36/89

.....



Taralay Premium 40

- Osmoz 43
- Indiana 44
- Metallica 47
- Brazilia 49
- Costa Rica 50
- Fusion 51

My Taralay Premium 52

Taralay Premium Dry-Tex™ 54

Taralay Element 56

- City 58

Taralay Impression/Uni NEW ... 60

- Corner 62
- Kubes 63
- Rice 64
- Stars 65
- Cemento 66
- Mohair 66
- Nest 67
- Trame 68
- Gentlemen 68
- Wood 69-73
- Uni 75

Taralay Initial NEW ... 76

- Diversion 78
- Strada 79
- Urban 80
- Tweedy 81
- Wood 82-85

Tarastep 86

MULTILAYERED FLOORING

↑
ABRASION RESISTANCE

Homogeneous wearlayer

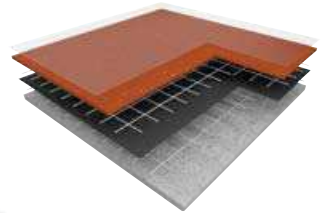

Taralay Element Comfort

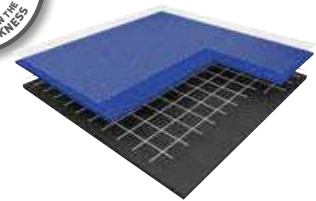

Taralay Element Compact

Clear wearlayer

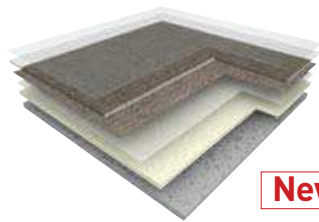

New

Taralay Initial Comfort



New

Taralay Initial Compact

Protocols® Treatment

MAINTENANCE

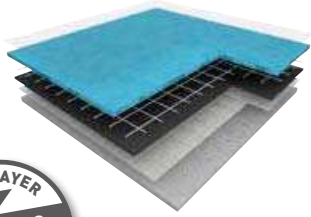

Taralay Premium
Comfort

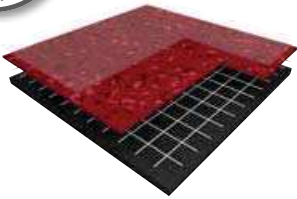

Taralay Premium
Compact

TARALAY PREMIUM

- A global offer 6 designs, 86 colours
- A decorative solution:
My Taralay
- A technical solution:
Dry-Text™ System

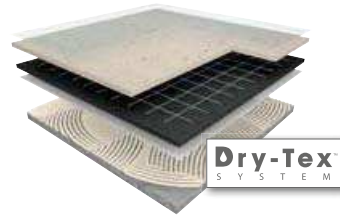

Taralay Premium
Dry-Text™ System

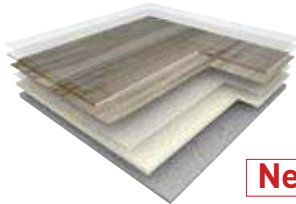

New

Taralay Impression Comfort*
Taralay Impression Comfort Plus**

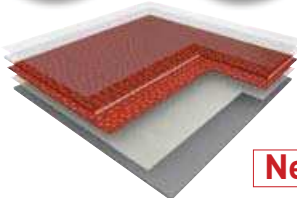

New

Taralay Impression Compact*
Taralay Impression Compact Plus**

PROTECSOL[®] 2 Treatment

MULTILAYERED FLOORING

TARALAY PREMIUM

TARALAY PREMIUM COMFORT.....

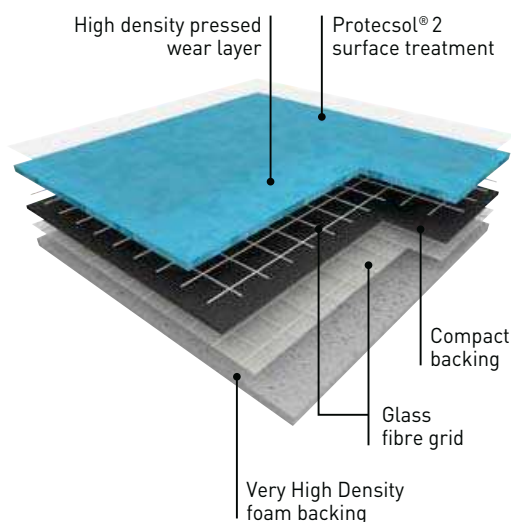

TARALAY PREMIUM COMFORT is a multilayered calendered and pressed vinyl floorcovering, with no filler and a group T wear rating, available in 2m wide sheet.

The product comprises a **>1mm thick, pure vinyl wear layer incorporating very densely pressed coloured chips**, with a **mat finishing** and **without a transparent wear layer**.

The product comprises a compact backing which is calendered, pressed and a Very High Density (VHD) foam backing. It is reinforced with a double glass fibre grid yielding a **16dB sound insulation**, **an indentation resistance of 0.06mm** and a **rolling heavy loads easiness**.

TARALAY PREMIUM COMFORT is treated with **Protocolsol® 2**, a surface treatment obtained by UV laser crosslinking. This Protocolsol® 2 ensures easy maintenance and eliminates permanently the need for acrylic emulsion (metallisation). It avoids staining of chemical products used in healthcare like iodine alcohol, Betadine, eosin and anti-bacterial hand gel.

It is composed of 40% of minerals and inexhaustible materials.

It is made of 100% controlled recycled materials.

It does not contain any heavy metals or CMR 1&2 and they are 100% compliant with REACH.

On demand, Taralay Premium is available with phthalate free.

The products emission rate of volatile organic compounds is **<10µg/m³ (TVOC after 28 days – ISO 16000-6)**.

It is 100% recyclable.

TARALAY PREMIUM COMPACT.....

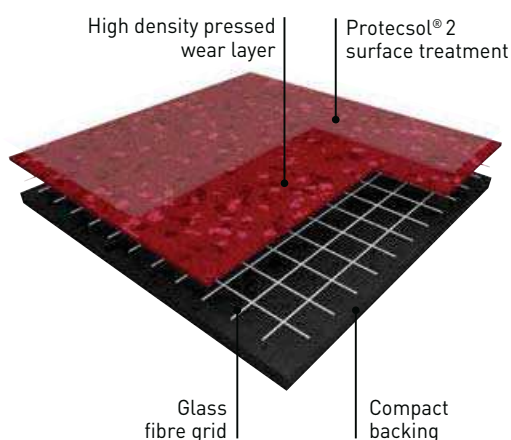

TARALAY PREMIUM COMPACT is a multilayered calendered and pressed vinyl floorcovering, with no filler and a group T wear rating, available in 2m wide sheet.

The product comprises a **>1mm thick, pure vinyl wear layer incorporating very densely pressed coloured chips**, with a **mat finishing** and **without a transparent wear layer**.

The product comprises a compact backing which is calendered, pressed and reinforced with a glass fibre grid yielding a **8dB sound insulation**, **an indentation resistance of 0.02mm** and a **rolling heavy loads easiness**.

TARALAY PREMIUM COMPACT is treated with **Protocolsol® 2**, a surface treatment obtained by UV laser crosslinking. This Protocolsol® 2 ensures easy maintenance and eliminates permanently the need for acrylic emulsion (metallisation). It avoids staining of chemical products used in healthcare like iodine alcohol, Betadine, eosin and anti-bacterial hand gel.

It is composed of 40% of minerals and inexhaustible materials.

It is made of 100% controlled recycled materials.

It does not contain any heavy metals or CMR 1&2 and they are 100% compliant with REACH.

On demand, Taralay Premium is available with phthalate free.

The products emission rate of volatile organic compounds is **<10µg/m³ (TVOC after 28 days – ISO 16000-6)**.

It is 100% recyclable.

TARALAY PREMIUM



16dB

Protocols[®] 2

100% recyclable

► **Outstanding durability**

Design within the whole thickness of the wear layer,
> 1mm thick

► **Long lasting appearance**

Pure vinyl wear layer (no filler, no transparent wear layer)
for the best scratch and soiling resistance

► **Easy maintenance & matt effect**

Protocols[®] 2 surface treatment

► **Excellent indoor air quality**

TVOC after 28 days < 10µg/m³

► **Rolling heavy loads easiness, best stability and very high performance indentation / acoustic**

0.06 mm / 16db for Comfort, 0.02 mm / 8db for Compact

Glass fibre grid reinforcement & very high density foam backing

| TARALAY PREMIUM COMFORT | TARALAY PREMIUM COMPACT |
|--------------------------------------------------------|-----------------------------------------------------------------|
| Osmoz - Indiana - Metallica - Brazilia - Costa Rica | Osmoz - Indiana - Metallica - Brazilia - Costa Rica - Fusion |

| DESCRIPTION | | | | |
|------------------------|-----------------------|--------|-------------|-------------|
| Total thickness | EN ISO 24346 [EN 428] | mm | 3.00 - 3.30 | 2.00 |
| Thickness of wearlayer | EN ISO 24340 [EN 429] | mm | > 1 | > 1 |
| Weight | EN ISO 23997 [EN 430] | g/sq.m | 2800 - 3260 | 2580 - 2680 |
| Width of sheet | EN ISO 24341 [EN 426] | cm | 200 | 200 |
| Length of sheet | EN ISO 24341 [EN 426] | lm | 25 | 20 |

| CLASSIFICATION | | | | |
|--------------------------------|-----------------------|-------|--------|-----------------------|
| Norm / Product specification | - | - | EN 651 | EN ISO 10582 [EN 649] |
| European classification | EN ISO 10874 [EN 685] | class | 34-42 | 34-43 |
| Fire rating | EN 13501-1 | class | Cfl-s1 | Bfl-s1 |
| Static electrical propensity | EN 1815 | kV | < 2 | < 2 |
| Slip resistance ⁽¹⁾ | DIN 51 130 | class | R10 | R10 |

| PERFORMANCES | | | | |
|------------------------------------------------------------------------|-------------------------|-----------------|--------------------------|--------------------------|
| Wear resistance | EN 660.2 | mm ³ | ≤ 2.0 | ≤ 2.0 |
| Wear group | NF 189 | group | T | T |
| Type Binder content | EN ISO 10582 | type | - | I |
| Dimensional stability | EN ISO 23999 [EN 434] | % | ≤ 0.40 | ≤ 0.40 |
| Residual indentation (requirement) | EN ISO 24343-1 [EN 433] | mm | ≤ 0.20 | ≤ 0.10 |
| Residual indentation (average measured value) | - | mm | ≈ 0.06 | ≈ 0.02 |
| Impact sound insulation | EN ISO 717-2 | dB | 16 | 8 |
| Castor chair test (type W) | ISO 4918 [EN 425] | - | OK | OK |
| Thermal conductivity | EN ISO 10456 [EN 12524] | W/(m.k) | 0.25 | 0.25 |
| Colour fastness | EN 20 105 - B02 | degree | ≥ 6 | ≥ 6 |
| Surface treatment | - | - | Protocols [®] 2 | Protocols [®] 2 |
| Chemical products resistance ⁽²⁾ | EN ISO 26987 [EN 423] | - | OK | OK |
| Anti-bacterial activity (E. coli - S. aureus - MRSA) ⁽³⁾ | ISO 22196 | - | > 99% inhibits growth | > 99% inhibits growth |

| ENVIRONMENT / INDOOR AIR QUALITY | | | | |
|----------------------------------|-------------|---------------------|-------------------------|-------------------------|
| TVOC after 28 days | ISO 16000-6 | µg / m ³ | <10 | <10 |
| Certification | - | - | Floorscore [®] | Floorscore [®] |

| CE MARKING | | | | |
|------------|----------|--|--------|--------|
| CE | EN 14041 | | | |
| | | | Cfl-s1 | Bfl-s1 |

(1) For lifetime sustainable wet resistance, please refer to Tarasafe ranges.

(2) Regarding the resistance to chemicals, please download the corresponding leaflet from our website.

(3) The implementation of an effective cleaning regime is the most important defence against infection.



MULTILAYERED FLOORING

TARALAY PREMIUM - OSMOZ



16dB

Protecsol® 2

100% recyclable

Multilayered
Flooring



3793 Cashmere Grey

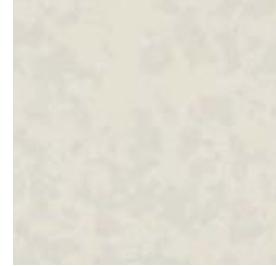

4344 Ivory

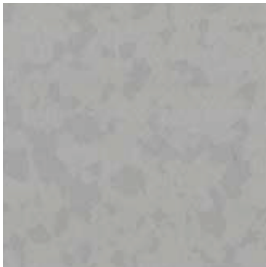

3792 Storm Grey



8255 Golden Sunset

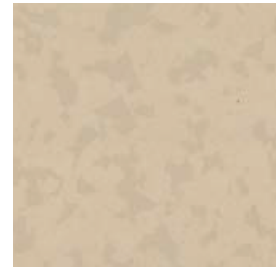

4347 Raphia



4348 Alpaga



4149 Mandarin



4527 Bamboo

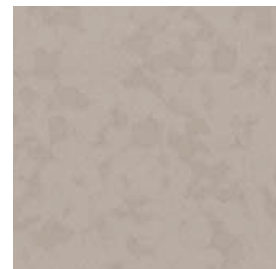

4349 Angora



4350 Elefant



4148 Scarlet Red



4496 Pacific Blue

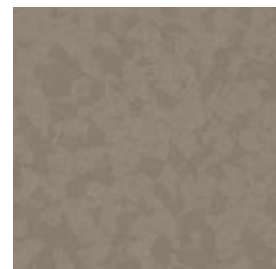

4351 Greige

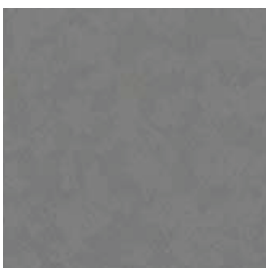

3791 Slate Grey



4143 Rose Shocking



4495 Atlantic Blue



8073 Cocoa

MULTILAYERED FLOORING

TARALAY PREMIUM - INDIANA



16dB

Protecsol® 2

100% recyclable

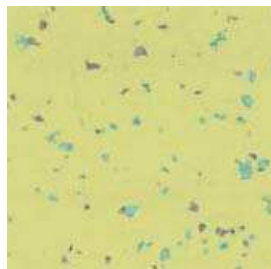

4015 Guinea

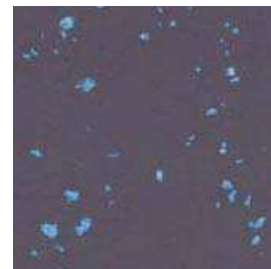

4133 Agalega



4526 Lasia



8254 Samui

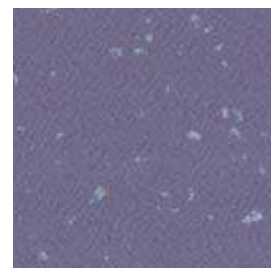

4135 Aldabra



4469 Pemba



8242 Masirah

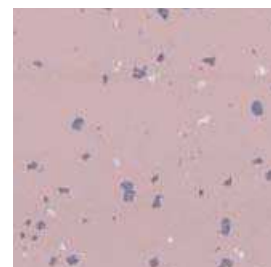

4140 Mahe

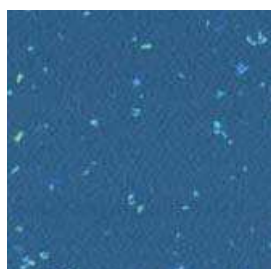

4476 Wattaru



4142 Penang

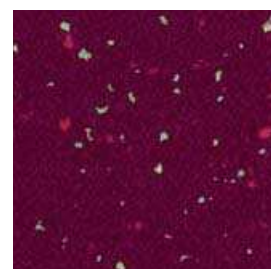

4145 Madura

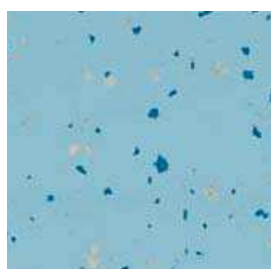

4475 Felidu

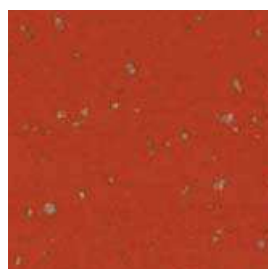

4146 Moheli



4141 Zanzibar



TARALAY PREMIUM - INDIANA

Dry-Tex™ S Y S T E M

- ▶ The all in one moisture solution
- ▶ Available with 4 references of Taralay Indiana

For any project please contact your Sales Representative for further technical information!

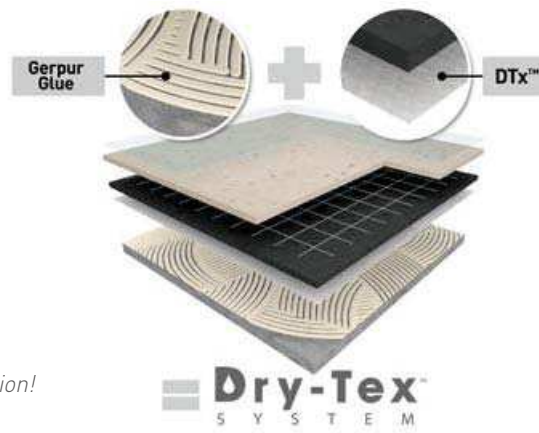

4009 Tufoa



4001 Ofu



4343 Tokelau*

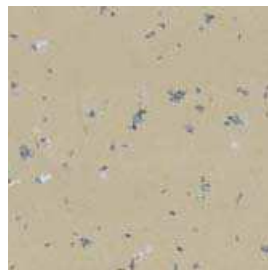

4029 Baduna



3788 Nauru

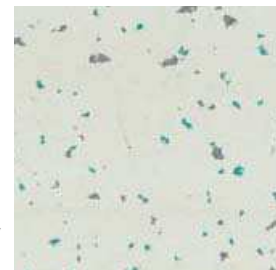

4002 Manua

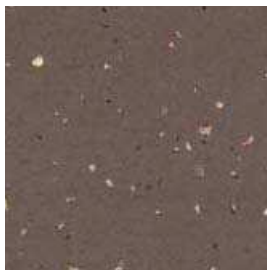

8057 Socotra

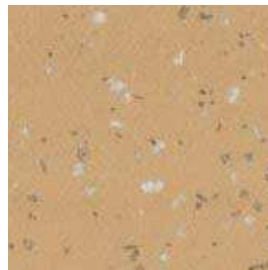

8262 Rodrigues



8053 Anambas*



4003 Tao*

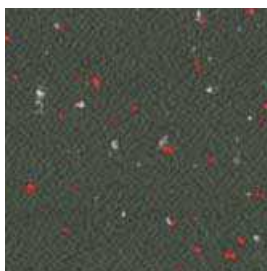

3705 Sumbawa

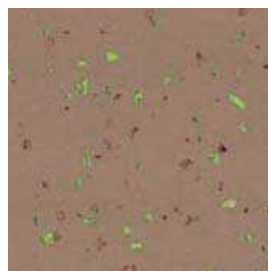

8059 Nicobar



4004 Pago*

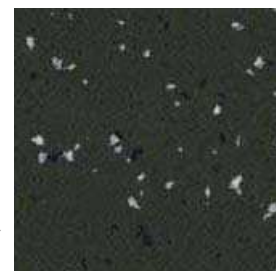

8837 Songo

**Product available as Taralay Premium & Taralay Premium Dry-Tex™.*



MULTILAYERED FLOORING

TARALAY PREMIUM - METALLICA



16dB

Protecsol® 2

100% recyclable



9330 Moon



9753 Energy



9506 Himalia



9302 Atlas



9719 Eclipse



9745 Cosmic



9002 Pulsar



9127 Meteorite



9415 Celeste



9310 Tethys





MULTILAYERED FLOORING

TARALAY PREMIUM - BRAZILIA



16dB

ProtecSol® 2



3734 Almerim

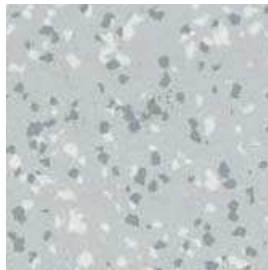

8736 Recife

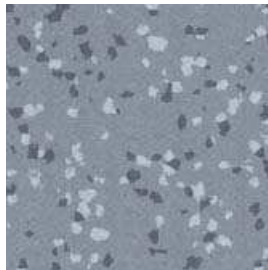

3709 Ceara

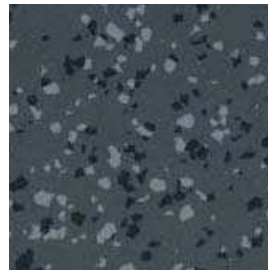

3707 Paraiba

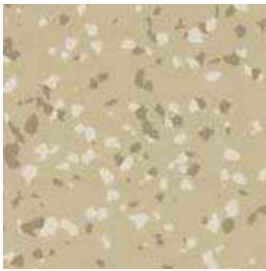

4729 Mato Grosso

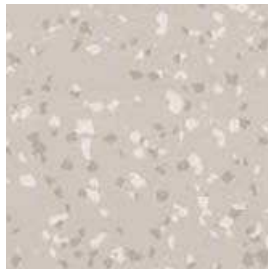

4342 Juara

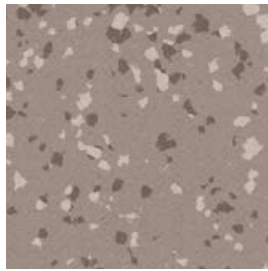

4329 Bacabal

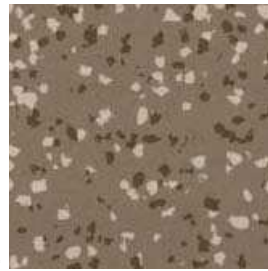

8062 Campinas



8386 Boa Vista

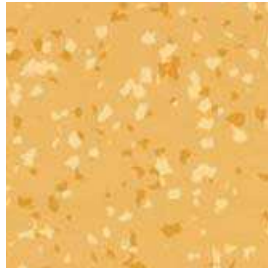

8269 Ipanema

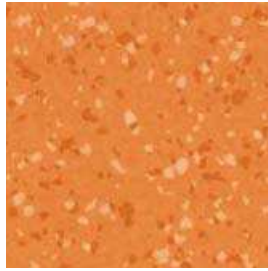

8157 Goiás

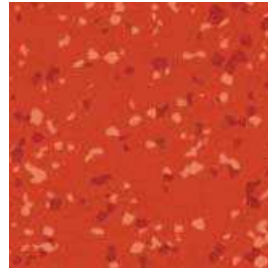

4136 Sao Luis



8577 Amazonas

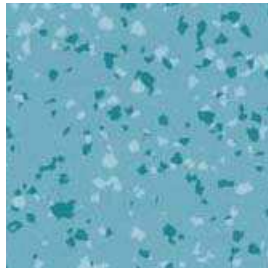

4477 Maceio

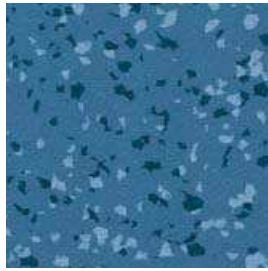

4478 Copacabana

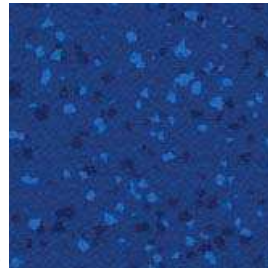

4481 Estancia



MULTILAYERED FLOORING

TARALAY PREMIUM - COSTA RICA



16dB

Protecsol® 2



100% recyclable



4743 Nublo

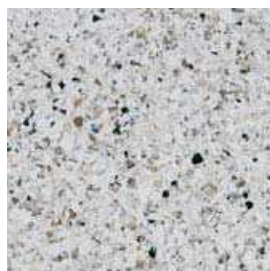

4794 Talamanca

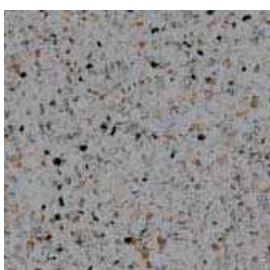

4752 Sombra

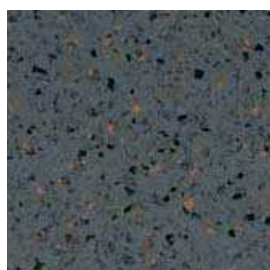

4746 Jaguar



8387 Balsa

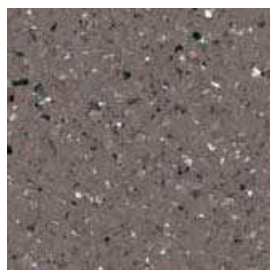

8191 Meseta

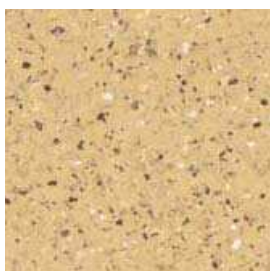

8395 Caballo

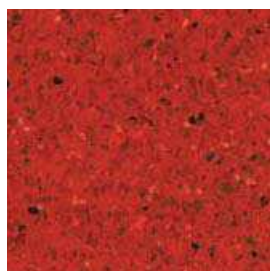

8183 Volcan

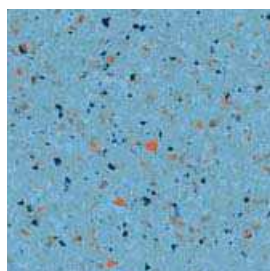

4454 Ara



TARALAY PREMIUM - FUSION



Protecsol® 2

100% recyclable



4753 Cotopaxi



4741 Lanzarote



4749 Vesuvio



4745 Lopevi



4748 Kamchatka

MULTILAYERED FLOORING

NEW PRODUCT OFFER: COLOURS ON DEMAND

A NEW SERVICE FOR CUSTOMISED FLOORS

My Taralay



AN EXCLUSIVE CONCEPT

The performance of the **Taralay Premium** range in the colours of your choice.

You want to **surprise** people with **flooring in harmony with space and light**, Gerflor gives you the **freedom** to build your own **unique decoration projects**.

Express your emotions, make up your own atmosphere, reinvent floors with My Taralay.



My Taralay creation
Brazilia
Education - France

HOW IT WORKS

1 Select a design type

layout

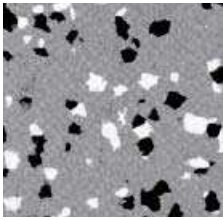

Brazilia type

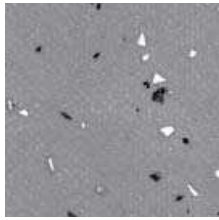

Indiana type

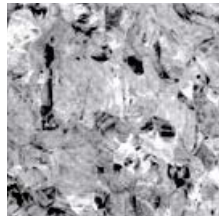

Fusion type

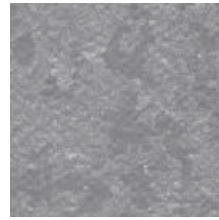

Osmoz type

2 Choose your granules

palette



3 Visualise your harmonies

and order online on mytaralaybygerflor.com



MULTILAYERED FLOORING

TARALAY PREMIUM DRY-TEX™ SYSTEM

THE _____
ALL-IN-ONE
MOISTURE
SOLUTION



The diagram illustrates the Dry-Tex System components. It shows a cross-section of the flooring system with two main parts: Gerpur, a fibrous mat, and DTx™, a black adhesive layer. A plus sign indicates they are combined. Below this, a 3D perspective view shows the layers: a top decorative slab, the DTx™ adhesive, and the Gerpur mat. The Dry-Tex SYSTEM logo is at the bottom.

All the performance of Taralay Premium (See page 44)



4343 Tokelau



8053 Anambas



4004 Pago



4003 Tao



And much more
for any slab with
high moisture

SAVE MONEY

- ✓ up to 70% cost savings compared to other third-party mitigation systems

SAVE TIME

- ✓ the only one-step, full-spread adhesive solution

RELIABLE SOLUTION

- ✓ over 500 000 sqm installed since 2009 with the same system used in Taraflex® Sports Flooring

HIGH PERFORMANCE SYSTEM

- ✓ proven to resist up to 98% RH

** For any project please contact your Sales Representative for further technical information!*



8dB

Protocolsol® 2

**Dry-TEX™**
S Y S T E M**TARALAY PREMIUM DRY-TEX™**

TARALAY PREMIUM DRY-TEX™ SYSTEM includes **TARALAY PREMIUM DRY-TEX™** and **GERPUR glue**.

This system provides a complete moisture mitigation in full-spread adhesive installation eliminating interposition barrier for any slab with high moisture (up to 98%RH).

TARALAY PREMIUM DRY-TEX™ is a multi-layered calendared and pressed vinyl floorcovering, with no filler and a group T wear rating, available in 2m wide sheet.

The product comprises a **>1mm thick homogeneous, pure vinyl wear layer incorporating very densely pressed coloured chips, with a mat finishing and without transparent wearlayer.**

The product comprises a 100% post-manufacturing compact reinforced with a glass fiber grid and a non-woven backing. The product offers 8dB sound insulation, an indentation resistance of 0.06mm and a rolling heavy loads easiness.

TARALAY PREMIUM DRY-TEX™ is treated with **Protocolsol®2**, a surface treatment obtained by UV laser crosslinking. This Protocolsol®2 ensures easy maintenance and eliminates permanently the need for acrylic emulsion (metallisation). It avoids staining of chemical products used in healthcare like iodine alcohol, Betadine, eosin and anti-bacterial hand gel.

It is composed of 40% of minerals and inexhaustible materials. It is made of 100% controlled recycled materials.

It does not contain any heavy metals or CMR 1&2 and they are 100% compliant with REACH.

The products emission rate of volatile organic compounds is **<10µg/m³ (TVOC after 28 days – ISO 16000-6).**

It is 100% recyclable.

TARALAY PREMIUM
DRY-TEX™

| DESCRIPTION | | | |
|---------------------------------------------------------------------|-------------------------|---------|-----------------------|
| Total thickness | EN ISO 24346 (EN 428) | mm | 2.50 |
| Thickness of wearlayer | EN ISO 24340 (EN 429) | mm | 1.02 |
| Weight | EN ISO 23997 (EN 430) | g/sq.m | 2660 |
| Width of sheet | EN ISO 24341 (EN 426) | cm | 200 |
| Length of sheet | EN ISO 24341 (EN 426) | lm | 20 |
| CLASSIFICATION | | | |
| Norm / Product specification | - | - | EN ISO 10582 (EN 649) |
| European classification | EN ISO 10874 (EN 685) | class | 34-43 |
| Fire rating | EN 13501-1 | class | Bfl-s1 |
| Static electrical propensity | EN 1815 | kV | < 2 |
| Slip resistance ⁽¹⁾ | DIN 51 130 | class | R10 |
| PERFORMANCES | | | |
| Wear resistance | EN 660.2 | mm³ | ≤ 2.0 |
| Wear group | NF 189 | group | T |
| Type Binder content | EN ISO 10582 | type | I |
| Dimensional stability | EN ISO 23999 (EN 434) | % | ≤ 0.40 |
| Residual indentation (requirement) | EN ISO 24343-1 (EN 433) | mm | ≤ 0.10 |
| Residual indentation (value) | - | mm | ≈ 0.03 |
| Castor chair test (type W) | ISO 4918 (EN 425) | - | OK |
| Thermal conductivity | EN ISO 10456 (EN 12524) | W/(m.k) | 0.25 |
| Impact sound insulation | EN ISO 717-2 | dB | 8 |
| Colour fastness | EN 20 105 - B02 | degree | ≥ 6 |
| Surface treatment | - | - | Protocolsol® 2 |
| Chemical products resistance ⁽²⁾ | EN ISO 26987 (EN 423) | - | OK |
| Anti-bacterial activity [E. coli - S. aureus - MRSA] ⁽³⁾ | ISO 22196 | - | > 99% inhibits growth |
| ENVIRONMENT / INDOOR AIR QUALITY | | | |
| TVOC after 28 days | ISO 16000-6 | µg / m³ | <10 |
| Certification | - | - | Floorscore® |
| CE MARKING | | | |
| CE | EN 14041 | | |

(1) For lifetime sustainable wet resistance, please refer to Tarasafe ranges.

(2) Regarding the resistance to chemicals, please download the corresponding leaflet from our website.

(3) The implementation of an effective cleaning regime is the most important defence against infection.

MULTILAYERED FLOORING

TARALAY ELEMENT



▶ TARALAY ELEMENT COMFORT

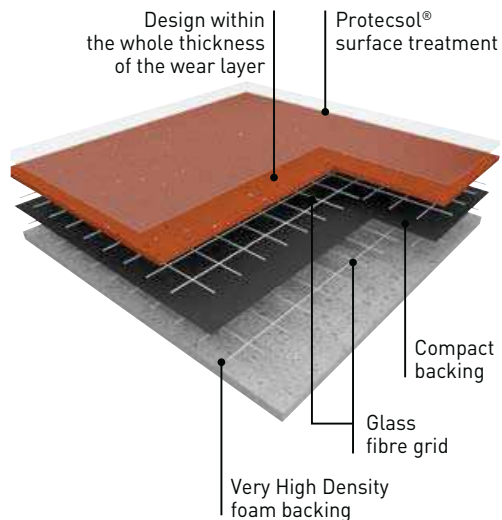

TARALAY ELEMENT COMFORT is a multilayered vinyl floorcovering available in 2m wide sheet, with a group T wear rating.

The product comprises a 0.75mm thick, pure vinyl and coloured wear layer throughout the thickness, without a transparent wear layer.

It comprises a Very High Density (VHD) foam and is reinforced with 2 fibre glass grids which yields a 17dB sound insulation rating and a resistance to indentation of 0.07mm.

This flooring is protected by the surface treatment, **Protocolsol®**, with a minimum thickness of 25µm, ensuring easy maintenance and no required polish for the entire lifetime of the product.

It is composed of 47% mineral and inexhaustible materials.

It does not contain any heavy metals or CMR 1&2 components and it is 100% compliant with REACH.

The product emission rate of volatile organic compounds is <10µg/m³ (TVOC after 28 days ISO 16000-6). It is 100% recyclable.

▶ TARALAY ELEMENT COMPACT

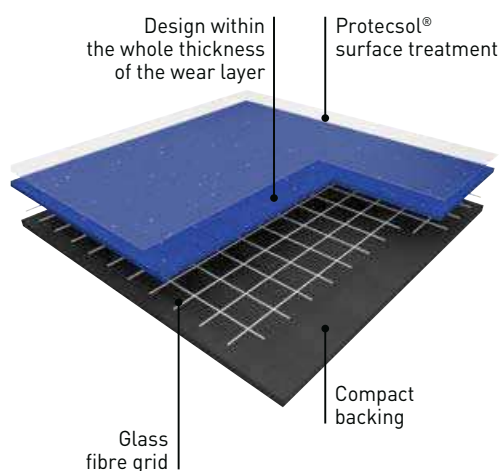

TARALAY ELEMENT COMPACT is a multilayered vinyl floorcovering available in 2m wide sheet, with a group T wear rating.

The product comprises a 0.75mm thick, pure vinyl and coloured wear layer throughout the thickness, without a transparent wear layer.

It is reinforced with a fibre glass grid for a better dimensional stability.

The construction of the product yields a 6 dB sound insulation rating.

This flooring is protected by the surface treatment, **Protocolsol®**, with a minimum thickness of 25µm, ensuring easy maintenance and no required polish for the entire lifetime of the product.

It is composed of 50% mineral and inexhaustible materials.

It does not contain any heavy metals or CMR 1&2 components and it is 100% compliant with REACH.

The product emission rate of volatile organic compounds is <10µg/m³ (TVOC after 28 days ISO 16000-6). It is 100% recyclable.

TARALAY ELEMENT



17dB

Protocolsol®

100% recyclable

- ▶ Durable and bright colours: inlaid design within the whole thickness of the wear layer
- ▶ Very High Density (VHD) foam with 2 fibre glass grids which yields a 17dB sound insulation rating and a resistance to indentation of 0.07mm
- ▶ Easy maintenance with Protocolsol® surface treatment

| | | | TARALAY ELEMENT COMFORT | TARALAY ELEMENT COMPACT |
|---------------------------------------------------------------------|-------------------------|---------------------|----------------------------|----------------------------|
| DESCRIPTION | | | | |
| Total thickness | EN ISO 24346 (EN 428) | mm | 3.0 | 2.0 |
| Thickness of wearlayer | EN ISO 24340 (EN 429) | mm | 0.75 | 0.75 |
| Weight | EN ISO 23997 (EN 430) | g/sq.m | 2850 | 2700 |
| Width of sheet | EN ISO 24341 (EN 426) | cm | 200 | 200 |
| Length of sheet | EN ISO 24341 (EN 426) | lm | 25 | 20 |
| CLASSIFICATION | | | | |
| Norm / Product specification | - | - | EN 651 | EN ISO 10582 (EN 649) |
| European classification | EN ISO 10874 (EN 685) | class | 34-42 | 34-43 |
| Fire rating | EN 13501-1 | class | Cfl-s1 | Bfl-s1 |
| Static electrical propensity | EN 1815 | kV | < 2 | < 2 |
| Slip resistance ⁽¹⁾ | DIN 51 130 | class | R10 | R10 |
| PERFORMANCES | | | | |
| Wear resistance | EN 660.2 | mm ³ | ≤ 2.0 | ≤ 2.0 |
| Wear group | NF 189 | group | T | T |
| Type Binder content | EN ISO 10582 | type | - | I |
| Dimensional stability | EN ISO 23999 (EN 434) | % | ≤ 0.40 | ≤ 0.40 |
| Residual indentation (requirement) | EN ISO 24343-1 (EN 433) | mm | ≤ 0.20 | ≤ 0.10 |
| Residual indentation (average measured value) | - | mm | ≈ 0.07 | ≈ 0.03 |
| Impact sound insulation | EN ISO 717-2 | dB | 17 | 6 |
| Castor chair test (type W) | ISO 4918 (EN 425) | - | OK | OK |
| Thermal conductivity | EN ISO 10456 (EN 12524) | W/(m.k) | 0.25 | 0.25 |
| Colour fastness | EN 20 105 - B02 | degree | ≥ 6 | ≥ 6 |
| Surface treatment | - | - | Protocolsol® | Protocolsol® |
| Chemical products resistance ⁽²⁾ | EN ISO 26987 (EN 423) | - | OK | OK |
| Anti-bacterial activity [E. coli - S. aureus - MRSA] ⁽³⁾ | ISO 22196 | - | > 99% inhibits growth | > 99% inhibits growth |
| ENVIRONMENT / INDOOR AIR QUALITY | | | | |
| TVOC after 28 days | ISO 16000-6 | µg / m ³ | <10 | <10 |
| Certification | - | - | Floorscore® | Floorscore® |
| CE MARKING | | | | |
| CE | EN 14041 | | | |
| | | | | |

(1) For lifetime sustainable wet resistance, please refer to Tarasafe ranges.

(2) Regarding the resistance to chemicals, please download the corresponding leaflet from our website.

(3) The implementation of an effective cleaning regime is the most important defence against infection.

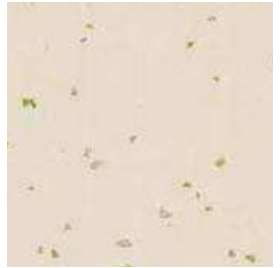

4341 Prague



4339 Agadir

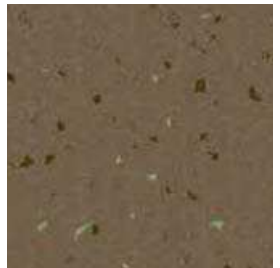

8068 Kinshasa



8252 Shanghai



4523 Rio

MULTILAYERED FLOORING

TARALAY ELEMENT - CITY



17dB

Protecsol®



100% recyclable

Multilayered
Flooring



3733 Stockholm



4337 Bilbao

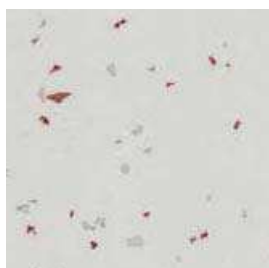

3739 Tokyo

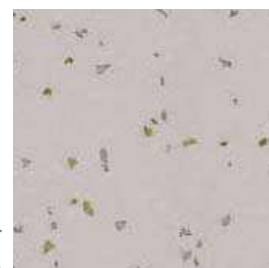

3744 Calgary

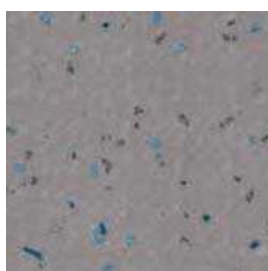

3743 New-York

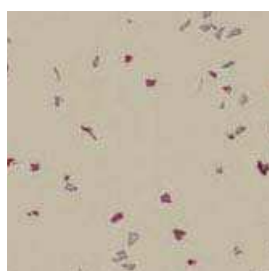

4338 London

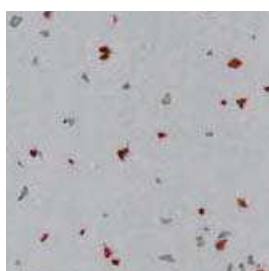

3732 Copenhagen

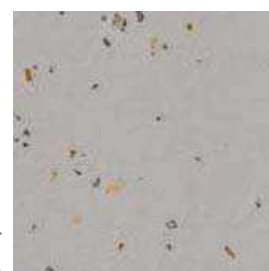

3753 Amsterdam

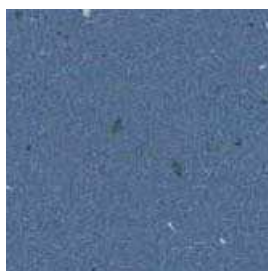

4487 Berlin

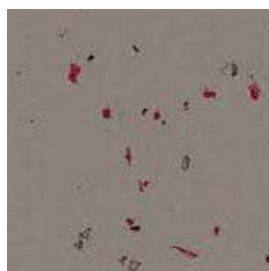

8067 Dakar



4340 Dubai



3752 Cape Town



4488 Santorini

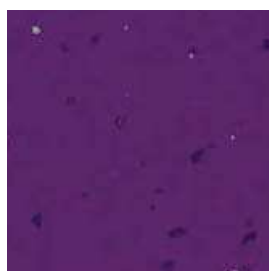

4144 Bangkok

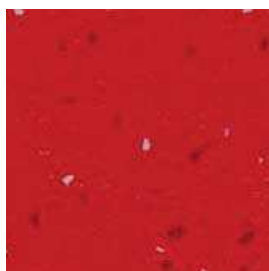

4134 Moscow

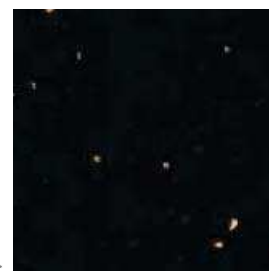

8846 Las Vegas

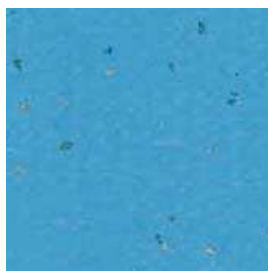

4490 Palermo

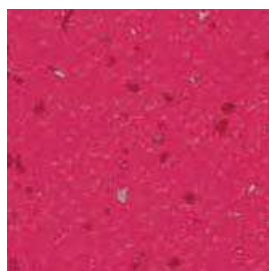

4138 Paris

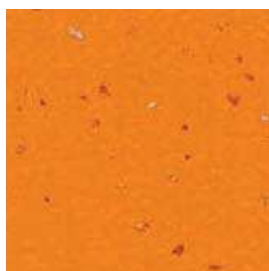

4115 Sydney

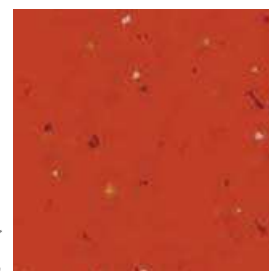

4117 Bamako

MULTILAYERED FLOORING

TARALAY UNI / IMPRESSION New

▶ TARALAY IMPRESSION COMPACT

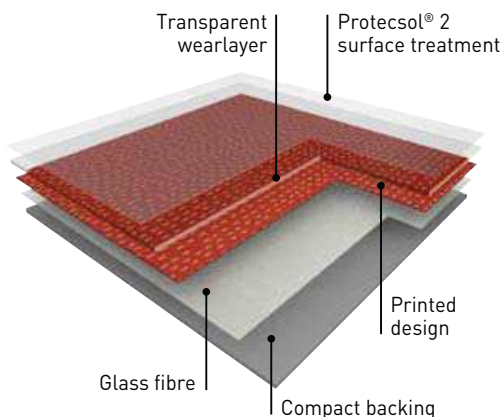

TARALAY IMPRESSION COMPACT 0,7 is a multi-layered vinyl floorcovering, available in 2m wide sheet, with a group T wear rating. The product comprises a compacted backing reinforced with a glass fibre and a printed design that is protected by a transparent wear layer (0.70 mm thick). **It offers 8 dB sound insulation and an indentation resistance of ca. 0.03 mm.**

TARALAY IMPRESSION COMPACT PLUS 0,9 is a multi-layered vinyl floorcovering, available in 2m wide sheet, with a group T wear rating.

The product comprises a compacted backing reinforced with a glass fibre and a printed design that is protected by a transparent wear layer (0.90 mm thick). **It offers 8 dB sound insulation and an indentation resistance of ca. 0.03 mm.**

The flooring is equipped with **Protocolsol® 2**, patented surface treatment obtained by UV laser cross-linking offering the best chemical resistance to the main products used in healthcare environment as betadine, eosin, hydro alcoholic solutions, making the maintenance easy and the floor long lasting. This treatment avoids applying any acrylic emulsion throughout the lifetime of the product.

It is free of formaldehyde, heavy metals and CMR 1 & 2 or vPvB (very persistent and very bio accumulative) or PBT (persistent, bio-accumulative and toxic) and is 100% REACH compliant. Its VOC emissions after 28 days (ISO 16000-6) are below detection levels (<10 µg / m³) and this product is classified A+ (the best class) and Floorscore® & M1 certified for indoor air quality. Taralay Impression Compact has antibacterial efficacy (E.coli / S.aureus / MRSA) : >99% after 24 hours according to ISO22196.

▶ TARALAY IMPRESSION COMFORT

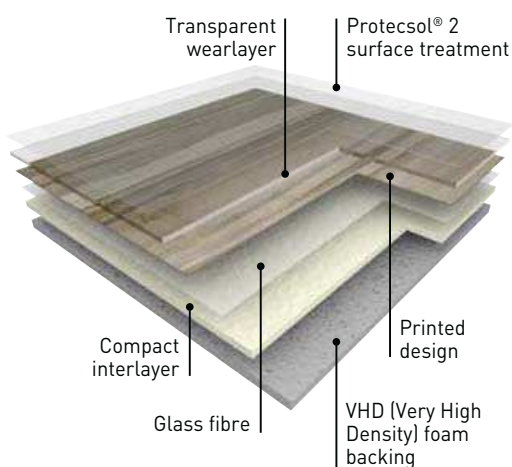

TARALAY IMPRESSION COMFORT 0,65 is an acoustic multi-layered vinyl floorcovering, available in 2m wide sheet, with a group T wear rating. The product comprises a Very High Density (VHD) foam backing reinforced with a glass fibre and a printed design that is protected by a transparent wear layer (0.65 mm thick). **It offers 19 dB sound insulation and an indentation resistance of ca. 0.08 mm.**

TARALAY IMPRESSION COMFORT PLUS 0,9 is an acoustic multi-layered vinyl floorcovering, available in 2m wide sheet, with a group T wear rating. The product comprises a Very High Density (VHD) foam backing reinforced with a glass fibre and a printed design that is protected by a transparent wear layer (0.90 mm thick). **It offers 19 dB sound insulation and an indentation resistance of ca. 0.08 mm.**

The flooring is equipped with **Protocolsol® 2**, patented surface treatment obtained by UV laser cross-linking offering the best chemical resistance to the main products used in healthcare environment as betadine, eosin, hydro alcoholic solutions, making the maintenance easy and the floor long lasting. This treatment avoids applying any acrylic emulsion throughout the lifetime of the product.

It is free of formaldehyde, heavy metals and CMR 1 & 2 or vPvB (very persistent and very bio accumulative) or PBT (persistent, bio-accumulative and toxic) and is 100% REACH compliant. Its VOC emissions after 28 days (ISO 16000-6) are below detection levels (<10 µg/m³) and this product is classified A+ (the best class) and Floorscore® & M1 certified for indoor air quality. Taralay Impression Comfort Plus has antibacterial efficacy (E.coli / S.aureus / MRSA): > 99% after 24 hours according to ISO22196.

▶ TARALAY UNI COMFORT

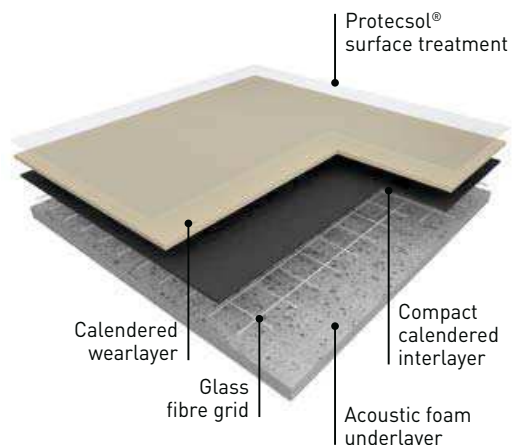

TARALAY UNI COMFORT is an acoustic multi-layered vinyl floor covering, available in 2m wide sheets, with a group T wear rating.

The product comprises a Very High Density (VHD) foam backing reinforced with glass fibre and a calendered wearlayer (0.65 mm thick). **It offers 17 dB sound insulation and an indentation resistance of 0.11mm.** It has a plain coloured design, making it ideal for cut design work.

It is protected by a UV-cured **Protocolsol®** surface treatment, which facilitates ease of maintenance and permanently eliminates the need for an acrylic emulsion (metallisation).

It does not contain any heavy metals or CMR 1&2 substances and it is 100% REACH compliant. The product emission rate of volatile organic compounds is < 10 µg/m³ (TVOC after 28 days – ISO 16000 -6). It is 100% recyclable.

TARALAY UNI / IMPRESSION

New



17dB
(TL Uni)

Protocols®

19dB
(TL Impression)

Protocols® 2

100% recyclable

- ▶ **ULTRA-REALISTIC DESIGNS:**
New embosses and new plank dimensions for wood designs
- ▶ **MATT EFFECT**
- ▶ **EXTREME STAIN RESISTANCE, EASY MAINTENANCE:**
Protocols® 2 surface treatment (patented technology by Gerflor)
- ▶ **HIGH TRAFFIC RESISTANCE, LONG-LASTING APPEARANCE**
Available with a 0.7mm wearlayer and available with a 0.9mm wearlayer upon request (minimum order quantity of 1600 sq.m)
- ▶ **THE BEST ACOUSTIC / INDENTATION PERFORMANCE ON THE MARKET**
COMPACT: 0.03 mm / 8 dB
COMFORT: 0.08 mm / 19 dB
- ▶ **ECO-RESPONSIBLE SOLUTION**
Best in class for indoor air quality (TVOC < 10 µg/m³ after 28 days)

| | | | TARALAY IMPRESSION COMPACT | TARALAY IMPRESSION COMPACT PLUS | TARALAY IMPRESSION COMFORT | TARALAY IMPRESSION COMFORT PLUS | TARALAY UNI COMFORT |
|---------------------------------------------------------------------|-------------------------|---------|----------------------------|---------------------------------|----------------------------|---------------------------------|-----------------------|
| DESCRIPTION | | | | | | | |
| Total thickness | EN ISO 24346 (EN 428) | mm | 2.00 | 2.25 | 3.35 | 3.55 | 3.00 |
| Wearlayer Thickness | EN ISO 24340 (EN 429) | mm | 0.70 | 0.90 | 0.65 | 0.90 | 0.65 |
| Weight | EN ISO 23997 (EN 430) | g/sq.m | 2635 | 2975 | 2825 | 3265 | 2300 |
| Width of sheet | EN ISO 24341 (EN 426) | cm | 200 | 200 | 200 | 200 | 200 |
| Length of sheet | EN ISO 24341 (EN 426) | lm | 25 | 20 | 25 | 20 | 25 |
| CLASSIFICATION | | | | | | | |
| Norm / Product specification | - | - | EN ISO 10582 (EN 649) | EN ISO 10582 (EN 649) | EN 651 | EN 651 | EN 651 |
| European classification | EN ISO 10874 (EN 685) | class | 34-43 | 34 - 43 | 34-42 | 34 - 42 | 34-42 |
| Fire rating | EN 13501-1 | class | Bfl-s1 | Cfl-s1 | Bfl-s1 | Cfl-s1 | Cfl-s1 |
| Static electrical propensity | EN 1815 | kV | < 2 | < 2 | < 2 | < 2 | < 2 |
| Slip resistance ⁽¹⁾ | DIN 51 130 | class | R10 | R10 | R10 | R10 | R10 |
| PERFORMANCES | | | | | | | |
| Wear resistance | EN 660.2 | mm³ | ≤ 2.0 | ≤ 2.0 | ≤ 2.0 | ≤ 2.0 | ≤ 2.0 |
| Wear group | NF 189 | group | T | T | T | T | T |
| Type Binder content | EN ISO 10582 | type | I | I | - | - | - |
| Dimensional stability | EN ISO 23999 (EN 434) | % | ≤ 0.40 | ≤ 0.40 | ≤ 0.40 | ≤ 0.40 | ≤ 0.40 |
| Residual indentation (requirement) | EN ISO 24343-1 (EN 433) | mm | ≤ 0.10 | ≤ 0.10 | ≤ 0.20 | ≤ 0.20 | ≤ 0.20 |
| Residual indentation (average measured value) | - | mm | ≈ 0.03 | ≈ 0.03 | ≈ 0.08 | ≈ 0.08 | ≈ 0.11 |
| Impact sound insulation | EN ISO 717-2 | dB | 8 | 8 | 19 | 19 | 17 |
| Castor chair test (type W) | ISO 4918 (EN 425) | - | OK | OK | OK | OK | OK |
| Thermal conductivity | EN ISO 10456 (EN 12524) | W/(m.k) | 0.25 | 0.25 | 0.25 | 0.25 | 0.25 |
| Colour fastness | EN 20 105 - B02 | degree | ≥ 6 | ≥ 6 | ≥ 6 | ≥ 6 | ≥ 6 |
| Surface treatment | - | - | PROTECSOL® 2 | PROTECSOL® 2 | PROTECSOL® 2 | PROTECSOL® 2 | Protocols® |
| Chemical products resistance ⁽²⁾ | EN ISO 26987 (EN 423) | - | OK | OK | OK | OK | OK |
| Anti-bacterial activity (E. coli - S. aureus - MRSA) ⁽³⁾ | ISO 22196 | - | > 99% inhibits growth | > 99% inhibits growth | > 99% inhibits growth | > 99% inhibits growth | > 99% inhibits growth |
| ENVIRONMENT / INDOOR QUALITY AIR | | | | | | | |
| TVOC after 28 days | ISO 16000-6 | µg / m³ | <10 | <10 | <10 | <10 | <10 |
| Certification | - | - | Floorscore® | Floorscore® | Floorscore® | Floorscore® | Floorscore® |
| CE MARKING | | | | | | | |
| CE | EN 14041 | | | | | | |

| | | | | | | | |
|----|----------|--|--|--|--|--|--|
| CE | EN 14041 | | | | | | |
|----|----------|--|--|--|--|--|--|

(1) For lifetime sustainable wet resistance, please refer to Tarasafe ranges.
 (2) Regarding the resistance to chemicals, please download the corresponding leaflet from our website.
 (3) The implementation of an effective cleaning regime is the most important defence against infection.

MULTILAYERED FLOORING

TARALAY IMPRESSION - CORNER

New



Comfort Compact 19dB ProtecSol® 2 100% recyclable

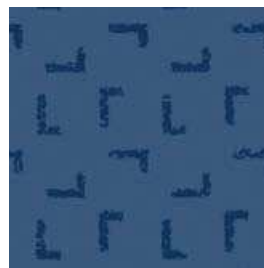

0732 - Corner Dark Blue



0728 - Corner Offwhite



0740 - Corner Turquoise



0729 - Corner Metal



0739 - Corner Anis



0730 - Corner Light Beige



0741 - Corner Tomette



0733 - Corner Copper

TARALAY IMPRESSION - KUBES

New



19dB

Protocols® 2



100% recyclable

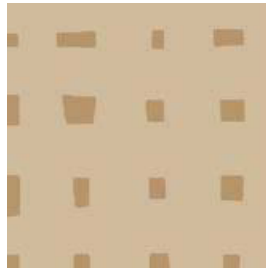

0756 - Kubes Beige



0755 - Kubes White

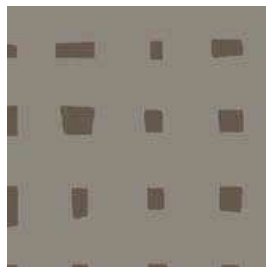

0751 - Kubes Taupe



0753 - Kubes Grey

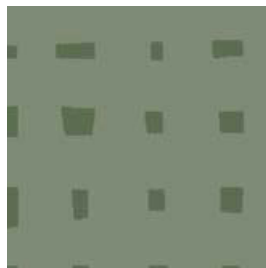

0747 - Kubes Olive



0754 - Kubes Blue



0748 - Kubes Burgundy

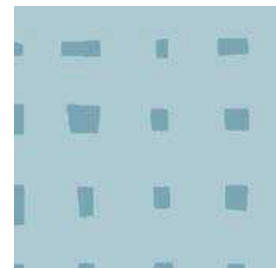

0749 - Kubes Sky



0752 - Kubes Gold



0750 - Kubes Sun



MULTILAYERED FLOORING

TARALAY IMPRESSION - RICE

New



Comfort Compact 19dB Protecsol® 2 100% recyclable



0763 - Rice Greige

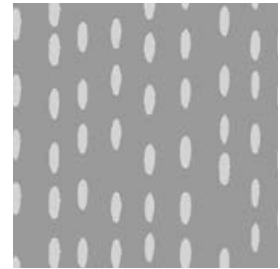

0737 - Rice Souris



0738 - Rice Copper



0758 - Rice Sea



0736 - Rice Champagne



0735 - Rice Light Green



0762 - Rice Brown



0757 - Rice Coquelicot



0759 - Rice Mustard

TARALAY IMPRESSION - STARS

New



Comfort | Compact | 19dB | Protocols® 2 | 100% recyclable

Multilayered
Flooring



0764 - Stars Orange



0743 - Stars Baltique



0744 - Stars Anthracite



MULTILAYERED FLOORING

TARALAY IMPRESSION - CEMENTO - MOHAIR

New



19dB | **Protecsol® 2** | **100% recyclable**

CEMENTO



0543 - Cemento Brescia



0523 - Cemento Genova



0525 - Cemento Modena



0524 - Cemento Capri

MOHAIR



0769 - Mohair White



0767 - Mohair Natural

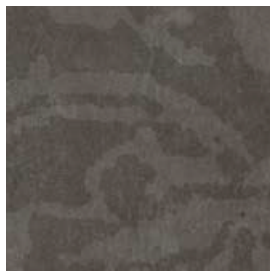

0766 - Mohair Dark



TARALAY IMPRESSION - NEST

New



Comfort Compact 19dB Protocolsol® 2 100% recyclable

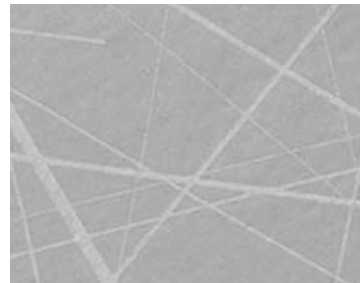

0745 - Nest Metal

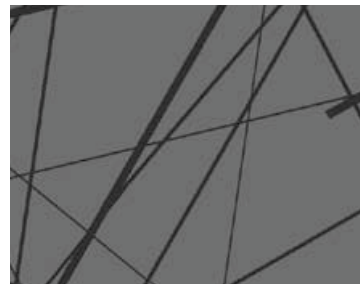

0746 - Nest Black



0765 - Nest Taupe

Multilayered
Flooring

MULTILAYERED FLOORING

TARALAY IMPRESSION - TRAME - GENTLEMEN

New



Comfort Compact | 19dB | Protecsol® 2 | 100% recyclable

TRAME



0774 - Trame Clear



0776 - Trame Beige



0777 - Trame Rose

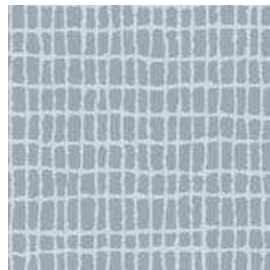

0775 - Trame Blue

GENTLEMEN



0772 - Gentlemen Coffee



0771 - Gentlemen Grey



0770 - Gentlemen Clear



TARALAY IMPRESSION - WOOD

New



Comfort Compact | 19dB | Protecsol® 2 | 100% recyclable

Multilayered
Flooring

HERRINGBONE



0722 - Herringbone Blond

HABANA



0538 - Habana Vinales



0724 - Herringbone Chatain



0522 - Habana Trinidad



MULTILAYERED FLOORING

TARALAY IMPRESSION - WOOD New



  **19dB** | **Protecsol® 2** |  **100% recyclable**

SYCAMORE



No plank
Continuous
design



0727 - Sycamore Vanilla



No plank
Continuous
design



0726 - Sycamore Dark



No plank
Continuous
design



0725 - Sycamore Light Brown

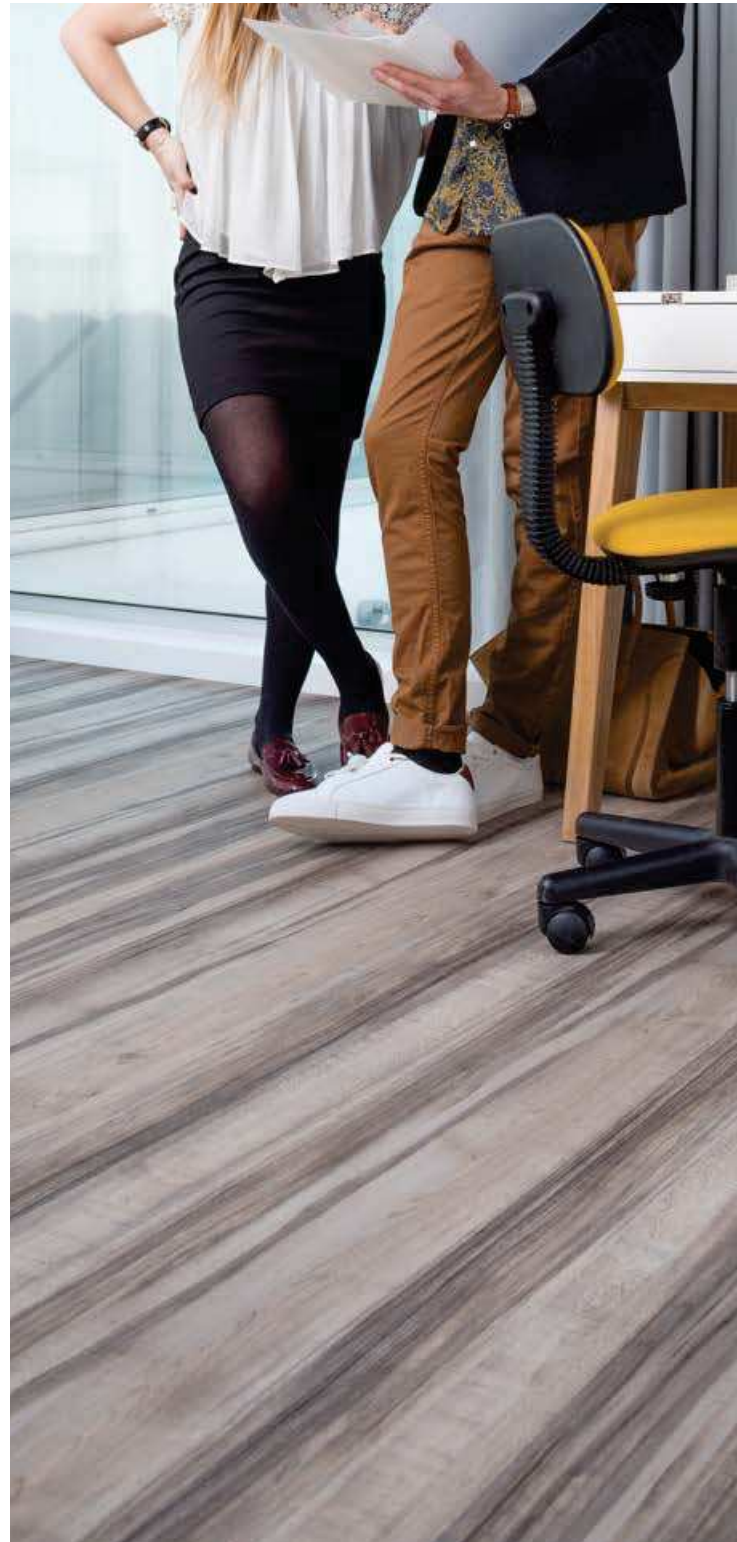

TARALAY IMPRESSION - WOOD New



19dB | **Protocols® 2** | **100% recyclable**

Multilayered
Flooring

LOFT



0671 - Loft Light Brown

WALNUT



0528 - Walnut Cream



0734 - Loft Chestnut



1314 - Walnut Brown

CHARME



0723 - Charme Pecan



0721 - Charme Natural



MULTILAYERED FLOORING

TARALAY IMPRESSION - WOOD New



19dB | **Protecsol® 2** | **100% recyclable**

NOMA



16,6 cm



0371 - Noma Rustic



16,6 cm



0373 - Noma Ice



16,6 cm



0519 - Noma Beige



PORTOBELLO



16,6 cm



0773 - Portobello

MOON ISLAND



16,6 cm



0760 - Moon Island

TARALAY IMPRESSION - WOOD New



19dB | **Protocols® 2** | **100% recyclable**

Multilayered Flooring

INFINITY



No plank Continuous design



0720 - Infinity Aube

RENZO



No plank Continuous design



0068 - Renzo Pecan



No plank Continuous design



0680 - Infinity Greige



No plank Continuous design



0025 - Renzo Taupe



No plank Continuous design



0719 - Infinity Lichen



| TARALAY IMPRESSION | | PLANKS SIZES IN CM | | |
|--------------------|---------------------|---------------------|--------|-------------------|
| Colour Reference | Colour Name | Pattern Repeat in m | Length | Width |
| 0519 | Noma Beige | 1000 X 1000 | 100 | 16,6 |
| 0373 | Noma Ice | 1000 X 1000 | 100 | 16,6 |
| 0371 | Noma Rustic | 1000 X 1000 | 100 | 16,6 |
| 0538 | Habana Vinales | 1000 X 1000 | 100 | 16,6 |
| 0552 | Habana Trinidad | 1000 X 1000 | 100 | 16,6 |
| 0528 | Walnut Cream | 1000 X 1000 | 100 | 10 |
| 1314 | Walnut Brown | 1000 X 1000 | 100 | 10 |
| 0671 | Loft Light Brown | 1000 X 1000 | 100 | 11,2-14,2-8,7-6,4 |
| 0734 | Loft Chestnut | 1000 X 1000 | 100 | 11,2-14,2 8,7-6,4 |
| 0721 | Charme Natural | 1000 X 1000 | 100 | 20 |
| 0723 | Charme Pecan | 1000 X 1000 | 100 | 20 |
| 0760 | Moonisland | 1000 X 1000 | 100 | 16,6 |
| 0773 | Portobello | 1000 X 1000 | 100 | 16,6 |
| 0722 | Herringbone Blond | 1000 X 1000 | 100 | 16,6 |
| 0724 | Herringbone Chatain | 1000 X 1000 | 100 | 16,6 |



MULTILAYERED FLOORING

TARALAY UNI COMFORT

New



 **17dB** | **Protocolsol®** |  **100% recyclable**



6265 - Uni Brown



6267 - Uni Beige



0778 - Uni Anthracite



6271 - Uni Grey

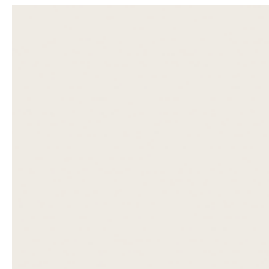

6273 - Uni White



6260 - Uni Dark Blue



6261 - Uni Blue

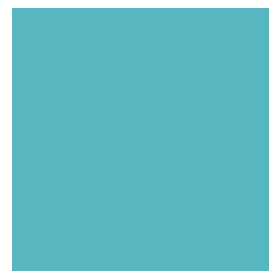

6262 - Uni Turquoise

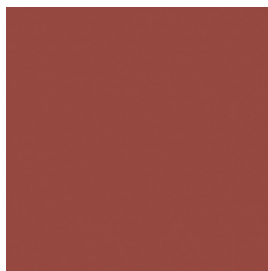

6270 - Uni Tomette



6264 - Uni Olive



6263 - Uni Anis



6269 - Uni Orange



6268 - Uni Sun



MULTILAYERED FLOORING

TARALAY INITIAL New

▶ TARALAY INITIAL COMPACT

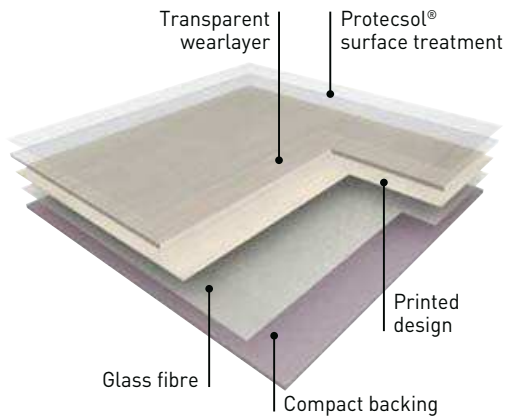

TARALAY INITIAL COMPACT is a multi-layered vinyl floorcovering, available in 2m wide sheet, with a group T wear rating.

The product comprises a compacted backing reinforced with a glass fibre and a printed design that is protected by a transparent wear layer (0.70 mm thick). It offers 6 dB sound insulation and an indentation resistance of 0.03 mm.

It is treated with **Protocolsol®**, a UV cured surface treatment, which facilitates ease of maintenance and eliminates permanently the need for acrylic emulsion (metallisation).

These products do not contain any heavy metals or CMR 1&2 and are 100% compliant with REACH. The products emission rate of volatile organic compounds is $< 10 \mu\text{g}/\text{m}^3$ (TVOC after 28 days – ISO 16000-6). It is 100% recyclable.

▶ TARALAY INITIAL COMFORT

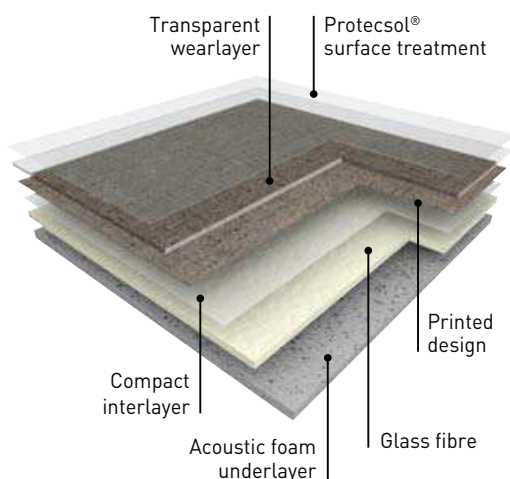

TARALAY INITIAL COMFORT is an acoustic multi-layered vinyl floorcovering, available in 2 m wide sheet, with a group T wear rating.

The product comprises a foam backing reinforced with a glass fibre and a printed design that is protected by a transparent wear layer (0.65 mm thick). It offers **19 dB** sound insulation and an indentation resistance of 0.10 mm.

It is treated with **Protocolsol®**, a UV cured surface treatment, which facilitates ease of maintenance and eliminates permanently the need for acrylic emulsion (metallisation).

It does not contain any heavy metals or CMR 1&2 and is 100% compliant with REACH. The products emission rate of volatile organic compounds is $< 10 \mu\text{g}/\text{m}^3$ (TVOC after 28 days – ISO 16000-6). It is 100% recyclable.

TARALAY INITIAL New



19dB

Protocolsol®



- ▶ All references are available in compact and comfort
- ▶ High resistance to indentation 0,03mm (Compact) and 0,10 mm (Comfort)
- ▶ High impact insulation 6dB (Compact) and 19dB (Comfort)
- ▶ Protocolsol® Surface Treatment (easy maintenance & no wax)
- ▶ Highest performance in TVOC emission < 10µg /m³

| | | | TARALAY INITIAL COMPACT PRO | TARALAY INITIAL COMFORT PRO |
|------------------------------------------------------------------------|-------------------------|---------------------|--------------------------------|--------------------------------|
| DESCRIPTION | | | | |
| Total thickness | EN ISO 24346 [EN 428] | mm | 2.00 | 3.35 |
| Thickness of wearlayer | EN ISO 24340 [EN 429] | mm | 0.70 | 0.65 |
| Weight | EN ISO 23997 [EN 430] | g/sq.m | 2635 | 2825 |
| Width of sheet | EN ISO 24341 [EN 426] | cm | 200 | 200 |
| Length of sheet | EN ISO 24341 [EN 426] | lm | 25 | 25 |
| CLASSIFICATION | | | | |
| Norm / Product specification | - | - | EN ISO 10582 [EN 649] | EN 651 |
| European classification | EN ISO 10874 [EN 685] | class | 34-43 | 34-42 |
| Fire rating | EN 13501-1 | class | Bfl-s1 | Bfl-s1 |
| Static electrical propensity | EN 1815 | kV | < 2 | < 2 |
| Slip resistance wet ⁽¹⁾ | DIN 51 130 | class | R10 | R10 |
| PERFORMANCES | | | | |
| Wear resistance | EN 660.2 | mm ³ | ≤ 2.0 | ≤ 2.0 |
| Wear group | NF 189 | group | T | T |
| Type Binder content | EN ISO 10582 | type | I | - |
| Dimensional stability | EN ISO 23999 [EN 434] | % | ≤ 0.40 | ≤ 0.40 |
| Residual indentation (requirement) | EN ISO 24343-1 [EN 433] | mm | ≤ 0.10 | ≤ 0.20 |
| Residual indentation (average measured value) | - | mm | ≈ 0.03 | ≈ 0.10 |
| Impact sound insulation | EN ISO 717-2 | dB | 6 | 19 |
| Castor chair test (type W) | ISO 4918 [EN 425] | - | OK | OK |
| Thermal conductivity | EN ISO 10456 [EN 12524] | W/(m.k) | 0.25 | 0.25 |
| Colour fastness | EN 20 105 - B02 | degree | ≥ 6 | ≥ 6 |
| Surface treatment | - | - | Protocolsol® | Protocolsol® |
| Chemical products resistance | EN ISO 26987 [EN 423] | - | OK | OK |
| Anti-bacterial activity [E. coli - S. aureus - MRSA] ⁽²⁾ | ISO 22196 | - | > 99% inhibits growth | > 99% inhibits growth |
| ENVIRONMENT / INDOOR AIR QUALITY | | | | |
| TVOC after 28 days | ISO 16000-6 | µg / m ³ | <10 | <10 |
| Certification | - | - | Floorscore® | Floorscore® |
| CE MARKING | | | | |
| | EN 14041 | | | |

(1) For lifetime sustainable wet resistance, please refer to Tarasafe ranges.

(2) The implementation of an effective cleaning regime is the most important defence against infection.

MULTILAYERED FLOORING

TARALAY INITIAL - DIVERSION

New

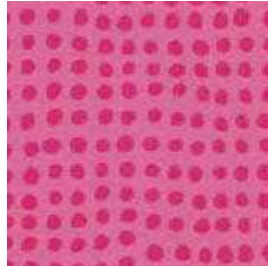

0599 Rose

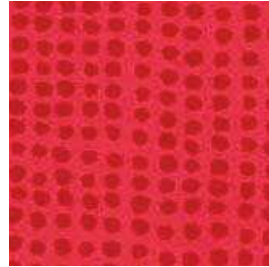

0595 Grenade

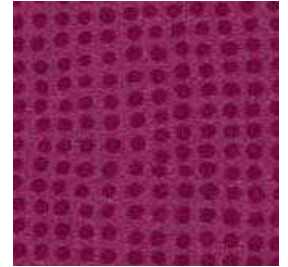

0516 Bordeaux



0600 Clementine



0596 Mimosa



0515 Kiwi

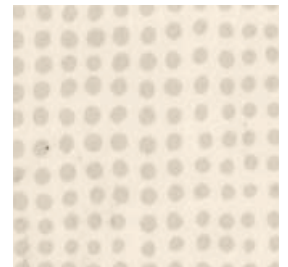

0047 Ivoire

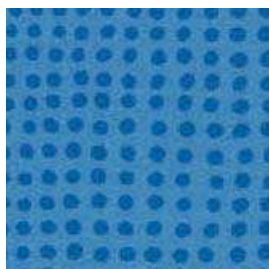

0597 Atlantique

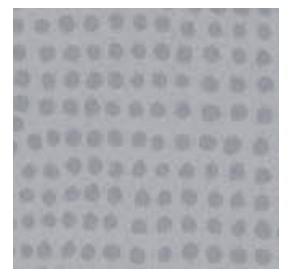

0824 Souris



0825 Turquoise



0049 Carbone

TARALAY INITIAL - STRADA New

  **19dB** | **Protectsol®** |  **100% recyclable**



0791 Metallic



0790 Chrome



0465 Ciment

MULTILAYERED FLOORING

TARALAY INITIAL - URBAN New

  **19dB** | **Protectsol®** |  **100% recyclable**

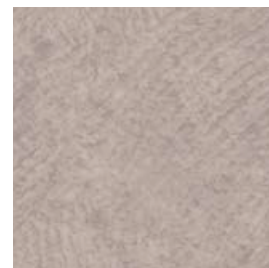

0037 Souris



0035 Gris



TARALAY INITIAL - TWEEDY New

  **19dB** | **Protcsol®** |  **100% recyclable**



0545 Natural



0823 Beige



0822 Taupe



MULTILAYERED FLOORING

TARALAY INITIAL - WOOD New

  **19dB** | **Protectsol®** |  **100% recyclable**



FILAMENT



No plank
Continuous
design



0829 Creme





No plank
Continuous
design



0799 Light



No plank
Continuous
design



0826 Grey

TARALAY INITIAL - WOOD New

  **19dB** | **Protectsol®** |  **100% recyclable**



Multilayered
Flooring

OTTAWA



6.2 cm

0779 Poplar

RENZO



No plank
Continuous
design

0590 Steel



No plank
Continuous
design

0069 Noisette



No plank
Continuous
design

0024 Chamois



MULTILAYERED FLOORING

TARALAY INITIAL - WOOD

New



19dB

Protecsol®



100% recyclable

Multilayered
Flooring

ESTEREL



0636 Blond



0518 Chocolate

HABANA



0797 Ivory



0828 Beige

NOMA



0588 Clair



0589 Marron

| Design name | Colour Reference | Colour Name | Pattern Repeat in m | Planks Sizes in cm | |
|-------------|------------------|-------------|---------------------|--------------------|-------|
| | | | | Length | Width |
| Esterel | 0636 | Blond | 1x1 | 100 | 10 |
| Esterel | 0518 | Chocolate | 1x1 | 100 | 10 |
| Habana | 0828 | Beige | 1x1 | 100 | 16,6 |
| Habana | 0797 | Ivory | 1x1 | 100 | 16,6 |
| Noma | 0588 | Clair | 1x1 | 100 | 16,6 |
| Noma | 0589 | Marron | 1x1 | 100 | 16,6 |
| Ottawa | 0592 | Poplar | 1x1 | 100 | 6.2 |

MULTILAYERED FLOORING

TARASTEP

▶ TARASTEP

ON THE WHOLE RANGE
MORE THAN
70%
CONTRAST

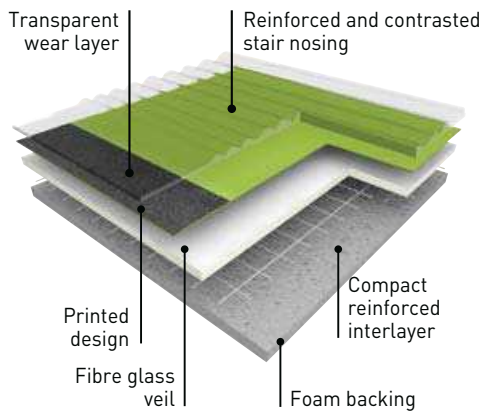

TARASTEP is a multilayered and foam backed complete step with a thickness of 3.35 mm. It comprises a printed design, a vinyl transparent wear layer and a specific embossing on stair nosing for safety.

It is an all-in-one stair covering comprising the stair tread, a ribbed nosing in a contrasted colour and the stair riser. All references have a 70% contrast level between stair tread and stair nosing to increase visibility for visually impaired people.

TARASTEP provides high sound insulation (17 dB).

The emissions of VOC after 28 days (NF EN 16000) are 100 µg / m³.

It is 100% recyclable.

▶ ACCESS FOR ALL

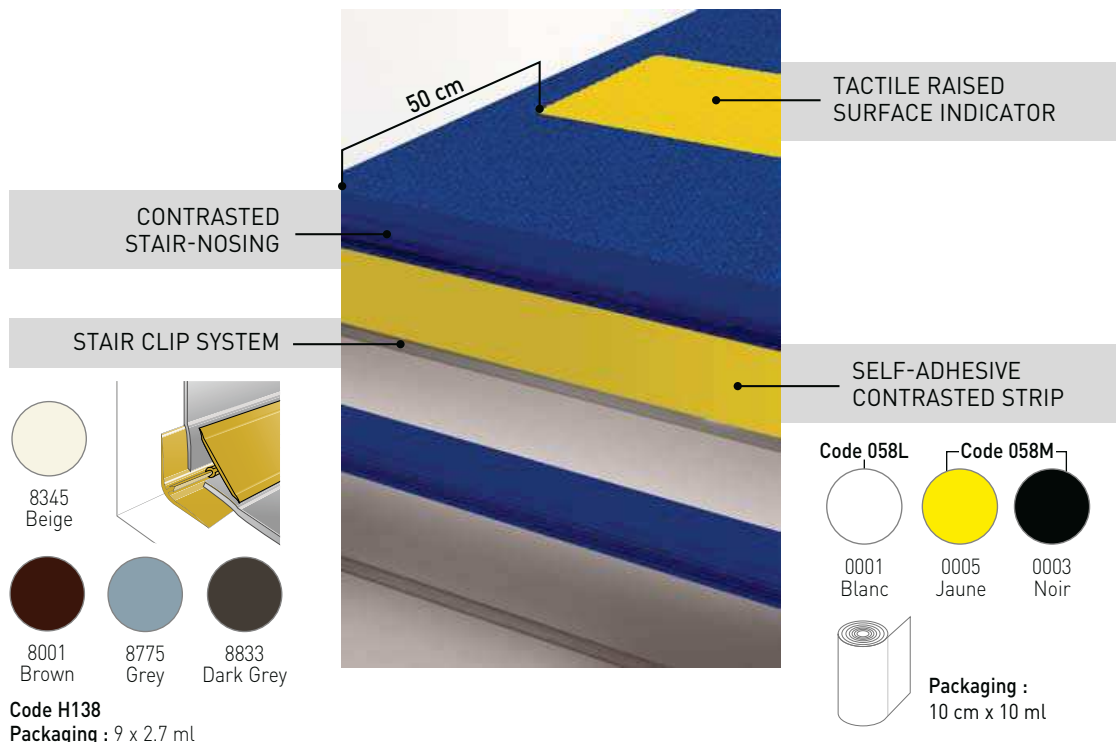

TARASTEP



100% recyclable

TARASTEP

DESCRIPTION

| | | | |
|------------------------|-----------------------|--------|------|
| Total thickness | EN ISO 24346 (EN 428) | mm | 3.35 |
| Thickness of wearlayer | EN ISO 24340 (EN 429) | mm | 0.85 |
| Weight | EN ISO 23997 (EN 430) | g/sq.m | 3100 |
| Width of sheet | EN ISO 24341 (EN 426) | cm | 101 |
| Length of sheet | EN ISO 24341 (EN 426) | lm | 20 |

CLASSIFICATION

| | | | |
|------------------------------|-----------------------|-------|--------|
| Norm / Product specification | - | - | EN 651 |
| European classification | EN ISO 10874 (EN 685) | class | 34-42 |
| Impact sound insulation | EN ISO 717-2 | dB | 17 |
| Room impact | NFS 31 074 | dB | < 65 |
| Fire rating | EN 13501-1 | class | Cfl-s1 |
| Static electrical propensity | EN 1815 | kV | < 2 |

PERFORMANCES

| | | | |
|-----------------------------------------------|-------------------------|-----------------|--------|
| Wear resistance | EN 660.2 | mm ³ | ≤ 2.0 |
| Wear group | NF 189 | group | T |
| Dimensional stability | EN ISO 23999 (EN 434) | % | ≤ 0.40 |
| Residual indentation (requirement) | EN ISO 24343-1 (EN 433) | mm | ≤ 0.20 |
| Residual indentation (average measured value) | - | - | 0.11 |
| Thermal conductivity | EN ISO 10456 (EN 12524) | W/(m.k) | 0.25 |
| Colour fastness | EN 20 105 - B02 | degree | ≥ 6 |
| Chemical products resistance | EN ISO 26987 (EN 423) | - | OK |

ENVIRONMENT / INDOOR QUALITY AIR

| | | | |
|--------------------|-------------|---------------------|------|
| TVOC after 28 days | ISO 16000-6 | µg / m ³ | <100 |
|--------------------|-------------|---------------------|------|

CE MARKING

| | | |
|----|----------|--|
| CE | EN 14041 | |
| | | |

MULTILAYERED FLOORING

TARASTEP



Comfort



100% recyclable

ON THE WHOLE RANGE
MORE THAN
70%
CONTRAST



0702 Chamois / Marron

71,2%
CONTRAST



0701 Taupe / Gris Clair

77,3%
CONTRAST



0703 Noisette / Beige

75,2%
CONTRAST



0721 Brun / Beige Clair

70,5%
CONTRAST

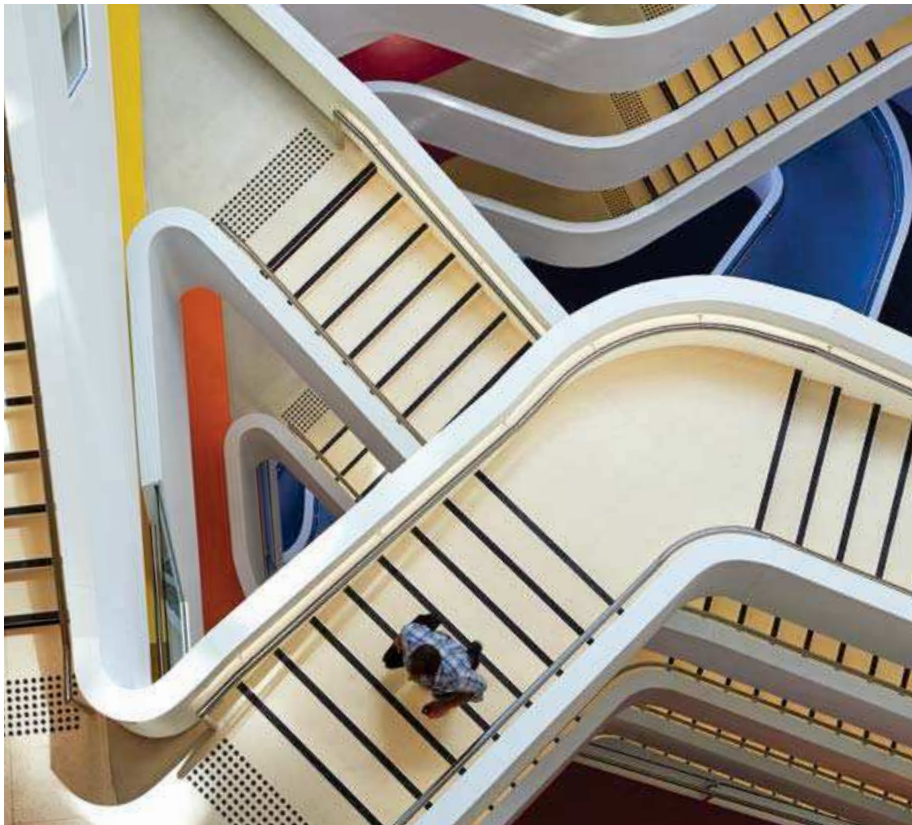

0719 Carbone / Jaune

72,9%
CONTRAST

TARASTEP

ON THE WHOLE RANGE
MORE THAN
70%
CONTRAST

Multilayered
 Flooring



0720 Beige Clair / Brun
81,3%
 CONTRAST



0722 Gris Clair / Carbone
75,9%
 CONTRAST

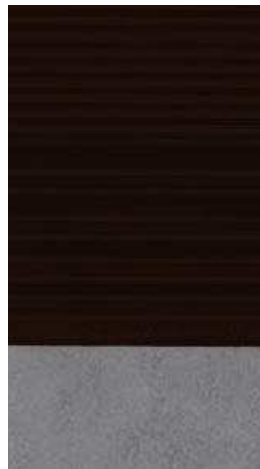

0714 Gris / Noir
75,6%
 CONTRAST



0723 Carbone / Gris Clair
73,3%
 CONTRAST



0724 Carbone / Bamboo
73,7%
 CONTRAST

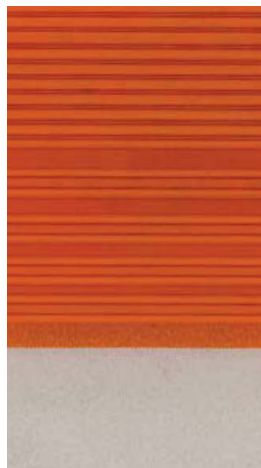

0718 Ivoire / Mandarine
70,3%
 CONTRAST



0717 Ivoire / Vermillon
71,5%
 CONTRAST



0716 Ivoire / Indigo
80,7%
 CONTRAST

The Tarastep range can be coordinated with Taralay ranges (<http://www.gerflor.com/media/virtual-library/other-technical-documents/gerflor-matching-tarastep-en.pdf>)



LUXURY
VINYL TILE

PAGES

90/191



Saga² NEW 94-99

Creation 70 100-131

- Creation 70 Exclusive Edition NEW 100-105
- Creation 70 106-115
- Creation 70 Clic System 116-123
- Creation 70 X'Press 124-127
- Accessories 128-131

Creation 55 132-167

- Creation 55 Exclusive Edition NEW 132-137
- Creation 55 138-149
- Creation 55 Clic System 150-159
- Creation 55 X'Press 160-163
- Accessories 164-167

Creation 30 168-191

- Creation 30 168-177
- Creation 30 Lock 178-183
- Creation 30 X'Press 184-187
- Accessories 188-191

LUXURY VINYL TILE

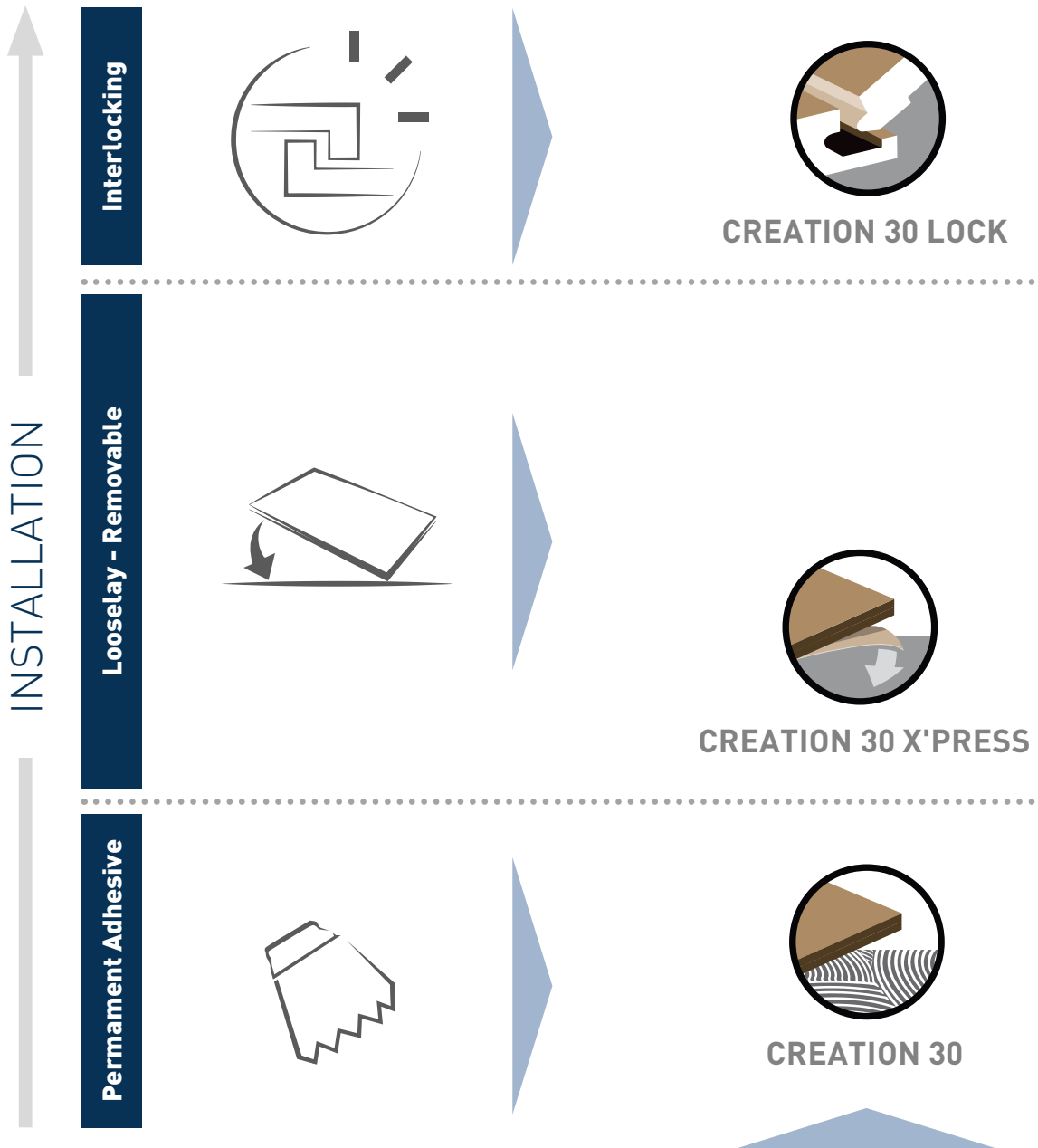

TRAFFIC



WEARLAYER THICKNESS

> 0.30 mm





reddot award 2016
winner



CREATION 55 CLIC SYSTEM



CREATION 70 CLIC SYSTEM



SAGA² **New**

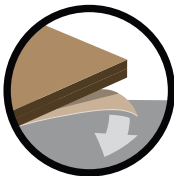

CREATION 55 X'PRESS

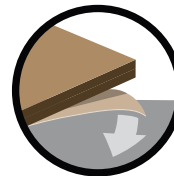

CREATION 70 X'PRESS

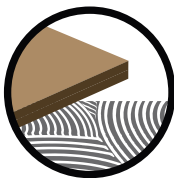

New
EXCLUSIVE / EDITION

CREATION 55

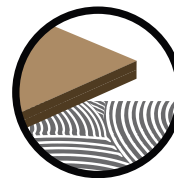

New
EXCLUSIVE / EDITION

CREATION 70



> 0.55 mm



> 0.70 mm

LUXURY VINYL TILE

SAGA² **New**

▶ SAGA²

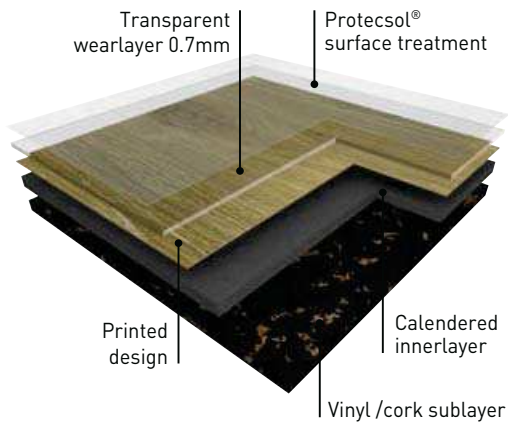

SAGA² is a noise reducing, decorative, group T, Vinyl flooring, available in 500 x 500 mm tiles.

It is made up of a transparent 0.7 mm thick surface layer with a decorative film, a calendered innerlayer and a Vinyl / Cork sublayer.

The total thickness of the tile is 4.6 mm.

SAGA² tiles are 100% recyclable.

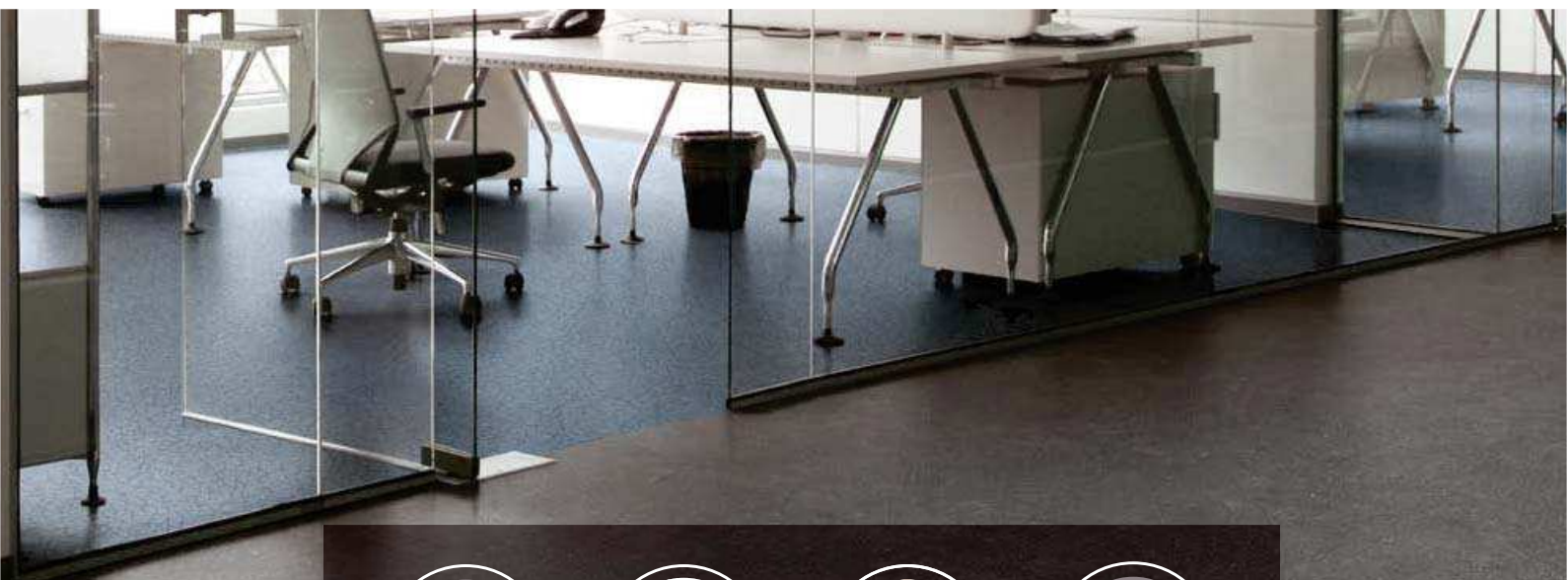

| | | | |
|---------------------------------------------------------------------------------------------------------|-------------------------------------------------------------------------------------|--------------------------------------------------------------------------------------------------------------------|-------------------------------------------------------------------------------------------------------------------|
|  <p>50x50 cm</p> |  |  <p>CORK INSIDE</p> |  <p><65 dB -15 dB</p> |
| Removable / Installation with Tackifier | Installation over existing floors* | Comfort & Resistance | Acoustic |



*For more information please refer to Gerflor's installation guidelines

SAGA² New

| | | | | |
|-------------------------------------------------------------------------------------------|-----------|------|------------|---------------------------------------------------------------------------------------------------|
|  Comfort | Removable | 15dB | Protecsol® |  100% recyclable |
|-------------------------------------------------------------------------------------------|-----------|------|------------|---------------------------------------------------------------------------------------------------|

► Fast track looselay tiles suitable for heavy traffic areas: offices , shops, public areas...

- Reusable
- Protecsol® surface treatment: easy to maintain
- Ideal for use alongside carpet tiles.

| | | | SAGA ² |
|-------------------------------------------------------------------------------------|-------------------------|-------------------------------------------------------------------------------------------------------------------------------------------------------------------------------------------------------------------------------------------------------------------|-------------------------|
| DESCRIPTION | | | |
| Total thickness | EN ISO 24346 (EN 428) | mm | 4.6 |
| Thickness of wearlayer | EN ISO 24340 (EN 429) | mm | 0.70 |
| Weight | EN ISO 23997 (EN 430) | g/sq.m | 5595 |
| Tile size | EN ISO 24342 (EN 427) | mm | 500.5 x 500.5 |
| Number of tiles per package | - | - | 10 |
| CLASSIFICATION | | | |
| Norm / Product specification | - | - | EN 652 |
| European classification | EN ISO 10874 (EN 685) | class | 34-42 |
| Fire rating | EN 13501-1 | class | Bfl-s1 |
| Static electrical propensity | EN 1815 | kV | < 2 |
| Slip resistance wet ⁽¹⁾ | DIN 51130 | class | R9 - R10 ⁽²⁾ |
| PERFORMANCES | | | |
| Wear resistance | EN 660.2 | mm ³ | ≤ 2.0 |
| Wear group | NF 189 | group | T |
| Dimensional stability | EN ISO 23999 (EN 434) | % | ≤ 0.15 |
| Residual indentation | EN ISO 24343-1 (EN 433) | mm | < 0.13 |
| Castor chair test (type W) | ISO 4918 (EN 425) | - | OK |
| Impact sound insulation | EN ISO 717-2 | dB | 15 |
| Thermal conductivity | EN ISO 10456 (EN 12524) | W/(m.k) | 0.25 |
| Colour fastness | EN 20 105 - B02 | degree | ≥ 6 |
| Surface treatment | - | - | Protecsol® |
| Chemical products resistance | EN ISO 26987 (EN 423) | - | OK |
| ENVIRONMENT / INDOOR AIR QUALITY | | | |
| TVOC after 28 days | ISO 16000-6 | µg / m ³ | <100 |
| Certification | - | - | Floorscore® |
| CE MARKING | | | |
|  | EN 14041 |    | |
| | |  | |

(1) Ramp test with oil

(2) Slip resistance wet: details on website gerflor.com

LUXURY VINYL TILE

SAGA² **New**



Comfort

Removable

15dB

Protocols[®]



100% recyclable

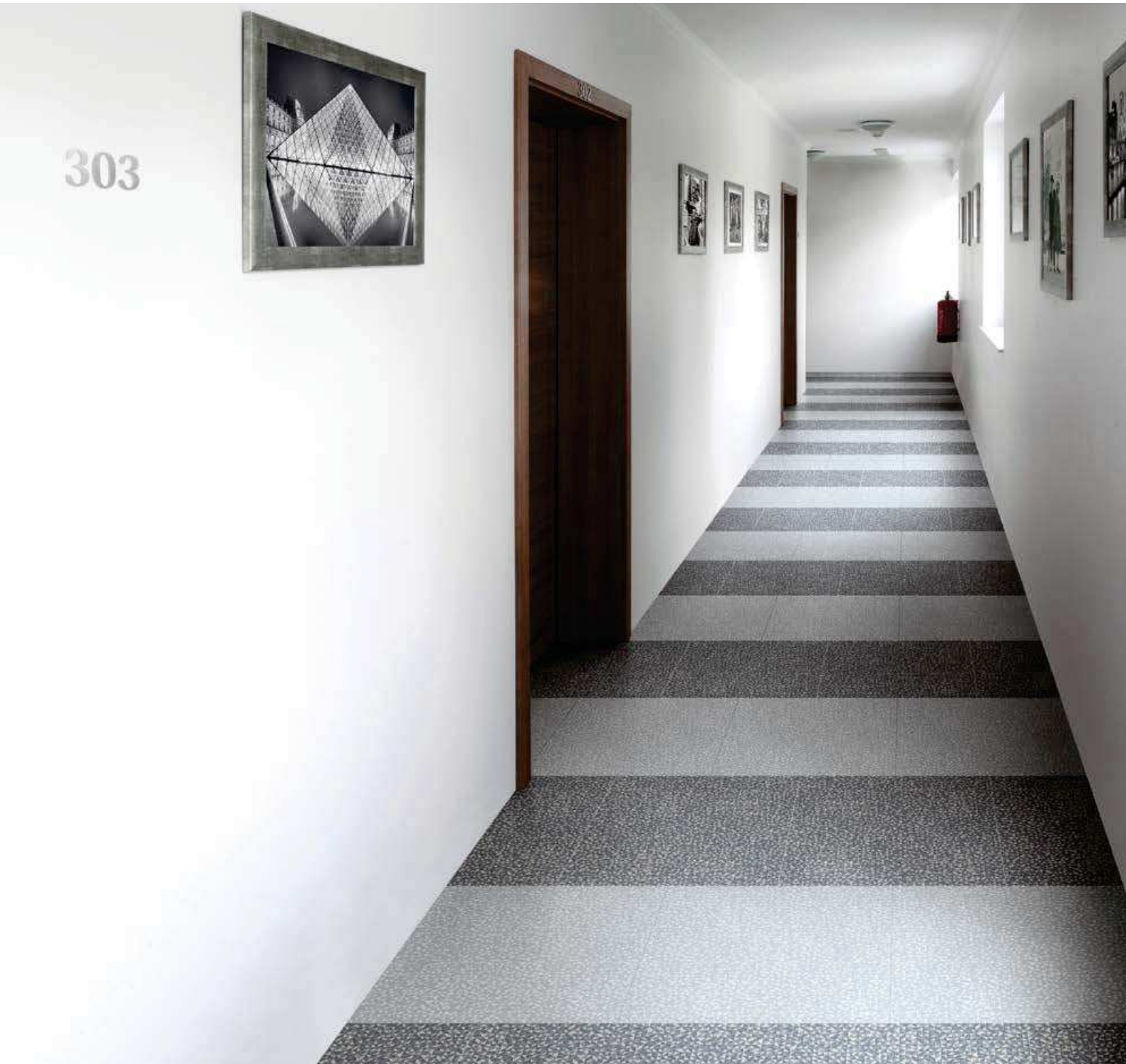

SAGA² New



Removable

15dB

Protocolsol®

100% recyclable



0063 Rough Textile Grey

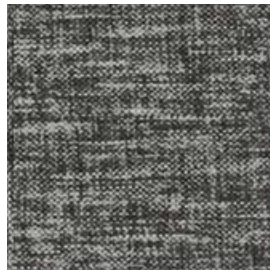

0088 Gentleman Grey



0017 Kadina City



0021 Barma Sweet



0023 Barma Mystery



0030 Gentleman Blue

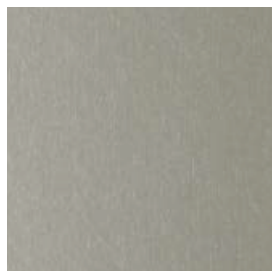

0028 Fiber Silver **METAL EFFECT**



0085 Dock Grey

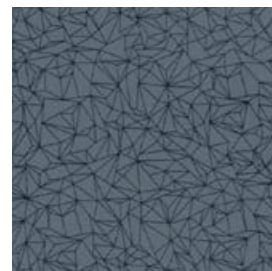

0039 Spider Blue

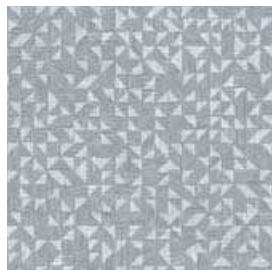

0032 Mozaic Grey

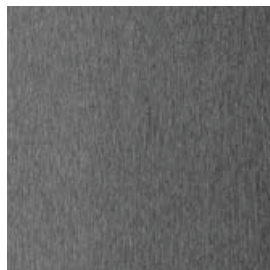

0027 Fiber Heavy Metal **METAL EFFECT**



0031 Mozaik Blue



Scale: 1/5

LUXURY VINYL TILE

SAGA² **New**



Comfort

Removable

15dB

Protocols[®]



100% recyclable



Gentleman Beige / Amarante

SAGA² New



Removable

15dB

Protecsol®

100% recyclable



0572 Amarante Dark



0035 Spider Taupe



0026 Fiber Copper

METAL EFFECT



0089 Gentleman Taupe



0087 Dock Taupe



0062 Rough Textile Beige



0029 Gentleman Beige



0033 Spider Beige



0579 Amarante



0025 Barma Beige



0577 Albion



Luxury Vinyl Tile

Scale: 1/5

DESIGN SHADE VARIATION:



Light



Medium

New

CREATION 70

EXCLUSIVE EDITION





LUXURY VINYL TILE

CREATION 70 **EXCLUSIVE EDITION** **New**



PUR+



CREATION 70 EXCLUSIVE EDITION New

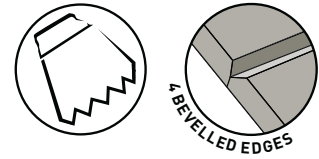

 Compact
  Compact
 PUR+
 100% recyclable



0805 Regimental Navy Blue 18.4x121.9 cm



0801 Solid Glam Navy Blue 18.4x121.9 cm



0807 Regimental Picadilly 18.4x121.9 cm



0803 Solid Glam Picadilly 18.4x121.9 cm



0808 Regimental Sherwood 18.4x121.9 cm



0804 Solid Glam Sherwood 18.4x121.9 cm



0799 Toasted Wood Cafe 23x150 cm



0800 Toasted Wood Roadster 23x150 cm

Luxury Vinyl Tile

DESIGN SHADE VARIATION:  Light  Medium  High

LUXURY VINYL TILE

CREATION 70 **EXCLUSIVE EDITION** **New**



PUR+

100% recyclable



CREATION 70 **EXCLUSIVE EDITION** New

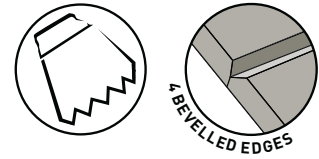

PUR+

100% recyclable



0797 Cervino Oak Beige

23x150 cm



0798 Cervino Oak Nature

23x150 cm



0088 Oxyd Pure

45.7x91.4 cm



0089 Oxyd Iron

45.7x91.4 cm



DESIGN SHADE VARIATION:



Light



Medium



High

Luxury Vinyl Tile

LUXURY VINYL TILE

CREATION 70

▶ CREATION 70

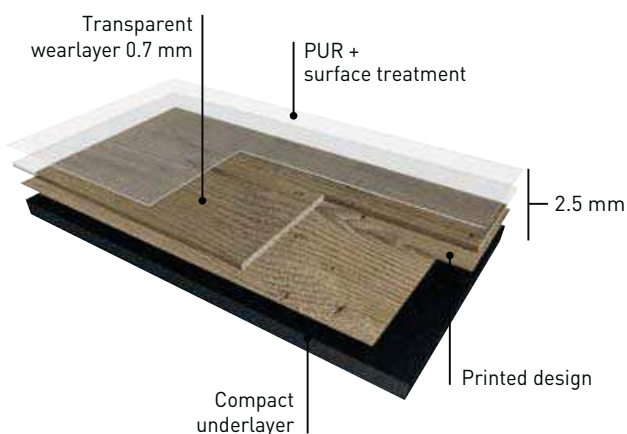

CREATION 70 are synthetic, decorative, flexible, antistatic, abrasion group T floorcoverings available in tile or plank forms.

CREATION 70 comprises a transparent wearlayer 0.7mm thick and bevelled edges.

CREATION 70 comprise a design film and a compact underlayer.

They are compressed and grained at high pressure.

CREATION 70 are treated with a polyurethane treatment **PUR+** providing excellent cleaning characteristics and improved resistance to scratching and chemicals. **PUR+** significantly delays the application of wax.

▶ CREATION 70 SLATE

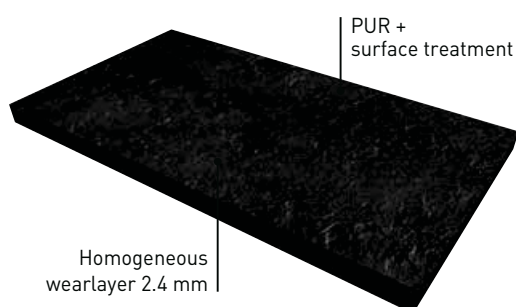

CREATION 70 SLATE is a synthetic, flexible bonded floor-covering available in tile form with bevelled edges.

It consists of a homogeneous wearlayer 2.4mm thick.

The floorcovering is compressed and grained at high pressure.

CREATION 70 SLATE is treated with a polyurethane treatment **PUR+** providing excellent cleaning characteristics and improved resistance to scratching and chemicals. **PUR+** significantly delays the application of wax.



CREATION 70



PUR+



reddot award 2016
winner

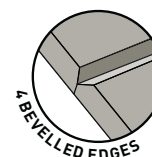
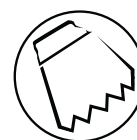

- ▶ **CREATION 70** is the first choice for public and commercial areas and is designed for high traffic wear.
- ▶ **CREATION 70**: low maintenance is due to Polyurethane surface treatment PUR+.

| | | | CREATION 70 | |
|-----------------------------------------|--------------------------|---------------------|-------------------------------------------------------------------------------------------------------------------------------------------------------------------------------|-----------------------|
| | | | DESIGN | SLATE |
| DESCRIPTION | | | | |
| Total thickness | EN ISO 24346 (EN 428) | mm | 2.50 | 2.40 |
| Thickness of wearlayer | EN ISO 24340 (EN 429) | mm | 0.70 | 2.40 |
| Weight | EN ISO 23997 (EN 430) | g/sq.m | 4100 | 3400 |
| Size | EN ISO 24342 (EN 427) | mm | Plank - 184x1371 / 184x1219 / 152x914 / 228x914 / 230x1500 Tile - 457x914 / 457x457/ 610x610 / 305x610/ Creation Mix : 152x914 / 228x914 / 76x914 | Tile - 305x610 |
| CLASSIFICATION | | | | |
| Norm / Product specification | - | - | EN ISO 10582 (EN 649) | EN ISO 10581 (EN 649) |
| European classification | EN ISO 10874 (EN 685) | class | 34-43 | 34-43 |
| Fire rating | EN 13501-1 | class | Bfl-s1 | Bfl-s1 |
| Static electrical propensity | EN 1815 | kV | < 2 | < 2 |
| Slip resistance wet | DIN 51 130 | class | R9 / R10 / R11 ^[1] | |
| PERFORMANCES | | | | |
| Wear resistance | EN 660.2 | mm ³ | ≤ 2.0 | ≤ 4.0 |
| Wear group | NF 189 | group | T | P |
| Type Binder content | ISO 10582 | type | I | - |
| | ISO 10581 | | - | I |
| Room impact | NF S 31074 | dB | 76 | 76 |
| Sound Insulation | EN ISO 717-2 | dB | 4 | 4 |
| Dimensional stability | EN ISO 23999 (EN 434) | % | ≤ 0.15 | ≤ 0.25 |
| Residual indentation | EN ISO 24343-1 (EN 433) | mm | ≤ 0.10 | ≤ 0.13 |
| Castor chair test (type W) | ISO 4918 (EN 425) | - | OK | OK |
| Thermal conductivity | EN ISO 10456 (EN 12 524) | W/(m.k) | 0.25 | 0.25 |
| Colour fastness | EN 20 105 - B02 | degree | ≥ 6 | ≥ 6 |
| Surface treatment | - | - | PUR+ | PUR+ |
| Chemical products resistance | EN ISO 26987 (EN 423) | - | OK | OK |
| ENVIRONMENT / INDOOR AIR QUALITY | | | | |
| TVOC after 28 days | ISO 16000-6 | µg / m ³ | <100 | <100 |
| Certification | - | - | - | - |
| CE MARKING | | | | |
| CE | EN 14041 | | | |
| | | | | |

[1] Slip resistance wet: details on website gerflor.com

LUXURY VINYL TILE

CREATION 70



0258 Muir Oak

10.1x91.4 cm
15.2x91.4 cm



0262 Elm

15.2x91.4 cm



0338 Bedgebury Oak

15.2x91.4 cm

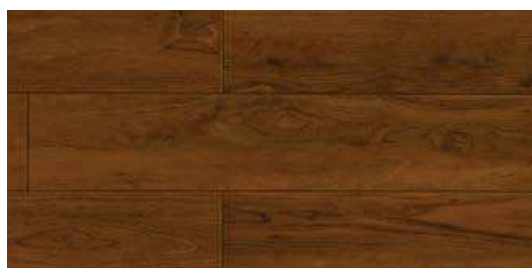

0265 Walnut

10.1x91.4 cm
15.2x91.4 cm



0541 Flamingo

15.2x91.4 cm

CREATION 70



reddot award 2016
winner

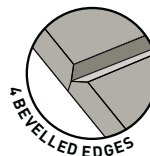
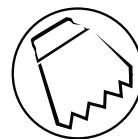

Compact



Compact

PUR+



100% recyclable



0272 Sorb

10.1x91.4 cm
15.2x91.4 cm



0329 Limed Oak

15.2x91.4 cm



0335 Sycamore

15.2x91.4 cm



0544 Cobargo

15.2x91.4 cm



0337 Victoria Oak

15.2x91.4 cm



0537 Aberdeen

15.2x91.4 cm



0260 Classic Oak

15.2x91.4 cm

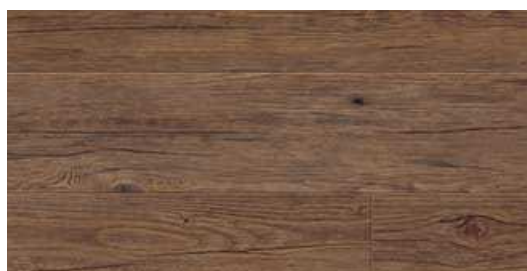

0360 Deep Forest

15.2x91.4 cm



0545 Serena

15.2x91.4 cm



0572 Carrington

18.4x121.9 cm



DESIGN SHADE VARIATION:



Light



Medium



High

Luxury Vinyl Tile

LUXURY VINYL TILE

CREATION 70



0538 Midwest

15.2x91.4 cm



0566 Fairview

18.4x121.9 cm



0539 Beverly

15.2x91.4 cm



0547 Duchess

15.2x91.4 cm



0552 Tanami

15.2x91.4 cm



0575 Spencer

18.4x137.1 cm



0556 Clifton

Creation 70 Mix
15.2x91.4 cm / 7.6x91.4 cm / 22.8x91.4 cm



0359 Wild Oak

15.2x91.4 cm



0573 Lawson

18.4x121.9 cm



0554 Columbus

15.2x91.4 cm



CREATION 70



reddot award 2016
winner

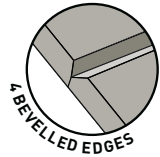
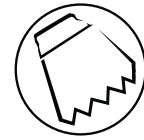

Compact



Compact

PUR+



100% recyclable



0535 Douglas

15.2x91.4 cm



0577 Albion

18.4x137.1 cm



0557 Gilmore

Creation 70 Mix
15.2x91.4 cm / 7.6x91.4 cm / 22.8x91.4 cm



0558 Bautista

Creation 70 Mix
15.2x91.4 cm / 7.6x91.4 cm / 22.8x91.4 cm



0340 Buxton Oak

15.2x91.4 cm



Luxury Vinyl Tile

DESIGN SHADE VARIATION:



Light



Medium



High

LUXURY VINYL TILE

CREATION 70



0085 Dock Grey

45.7x91.4 cm



0564 Masseria

18.4x121.9 cm



0563 Red Spirit

18.4x121.9 cm



0525 Atok

45.7x45.7 cm



0087 Dock Taupe

45.7x91.4 cm



CREATION 70



reddot award 2016
winner

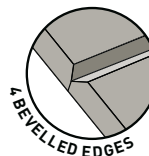
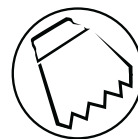

Compact



Compact

PUR+



100% recyclable



0570 Maruteca

18.4x121.9 cm



0560 Calabria

22.8x91.4 cm

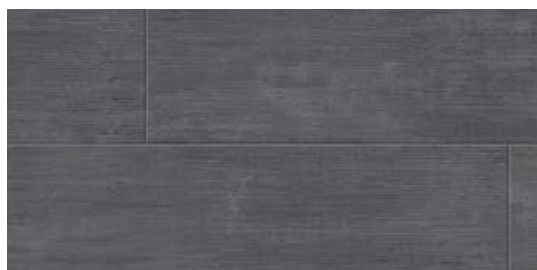

0561 Carassi

22.8x91.4 cm



0550 Hamilton

15.2x91.4 cm

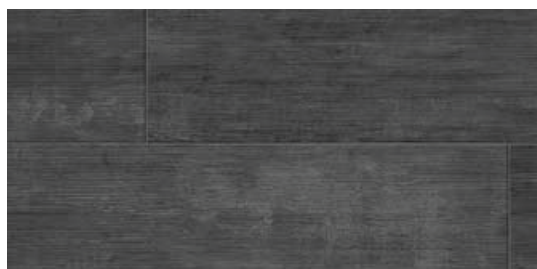

0562 Fidelio

22.8x91.4 cm



0529 Somerset

61x61 cm



0394 Welsh Slate

45.7x45.7 cm

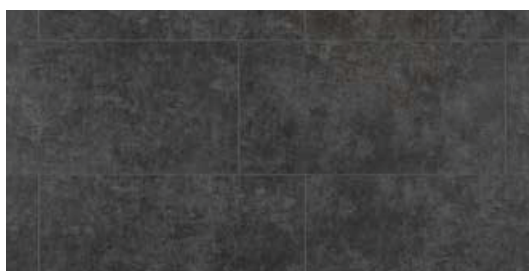

0512 Lewis Town

30.5x61 cm

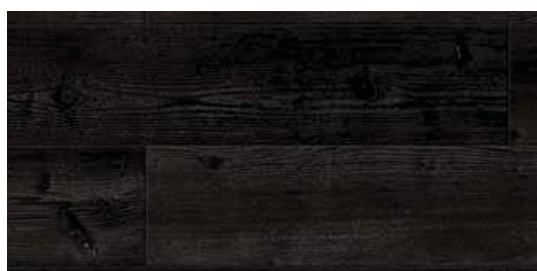

0540 Black Creek

15.2x91.4 cm



0114 Dark Slate

30.5x61 cm



DESIGN SHADE VARIATION:



Light



Medium



High

LUXURY VINYL TILE

CREATION 70



0414 Travertin Stone

30.5x61 cm



0576 Ocean Side

18.4x137.1 cm



0324 Silversands

15.2x91.4 cm



0565 Sheridan

18.4x121.9 cm

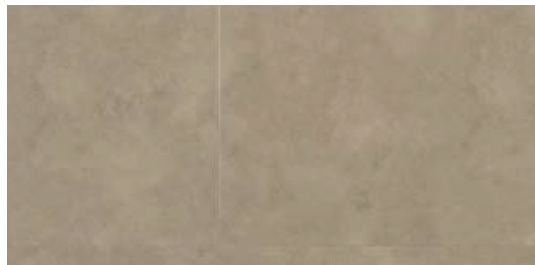

0528 Flagstaf

61x61 cm



0356 Denim Wood

15.2x91.4 cm



0569 Waterland

18.4x121.9 cm



0357 Portobello

15.2x91.4 cm



0358 Moon Island

15.2x91.4 cm



0568 Fargo

18.4x121.9 cm



DESIGN SHADE VARIATION:



Light



Medium



High

CREATION 70



reddot award 2016
winner

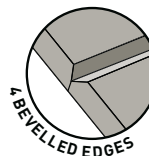
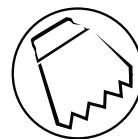

Compact



Compact

PUR+



100% recyclable



0402 Greenwich

45.7x45.7 cm



0089 Gentleman Taupe*

50 x 50 cm

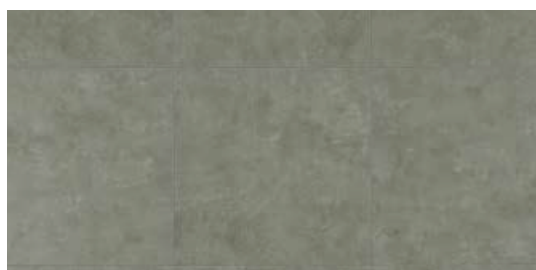

0522 East Village

45.7x45.7 cm
61x61 cm



0088 Gentleman Grey*

50 x 50 cm



0531 Halifax

61x61 cm

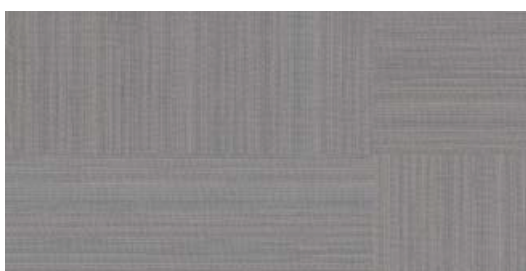

0021 Barma Sweet*

50 x 50 cm



DECORATIVE STRIPS



0330 Silver Strip

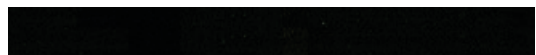

0331 Black Strip



0332 Light Concrete Strip



0333 Dark Concrete Strip



0334 Brown Concrete Strip

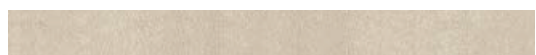

0335 White Concrete Strip

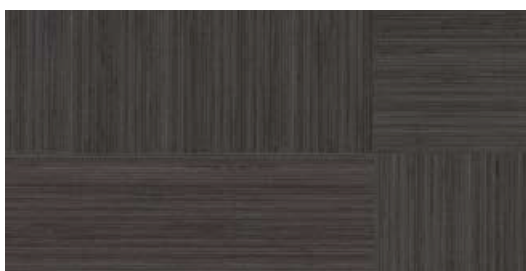

0023 Barma Mystery*

50 x 50 cm



**On demand for a minimum order quantity of 2100 sqm.*

| SIZE | PACKAGING | CODE |
|------------------|-------------------|------|
| Strip 4 x 914 mm | 1 pack = 80 units | 3203 |

CREATION CLIC (R)EVOLUTION

**EXCLUSIVE
VERTICAL CLIC**
NO ADHESIVE



**+EASY
+FAST
+QUIET**

NEW TOOL:
THE PRESSURE ROLLER

+RESISTANT

HIGH RESISTANCE
TO VERTICAL FORCE
AND TO HEAVY TRAFFIC



INSTALLATION ON GERFLOR ACOUSTIC UNDERLAY:

► BETTER IMPACT SOUND INSULATION



INSTALL DIRECTLY ON ANY SUBFLOOR**

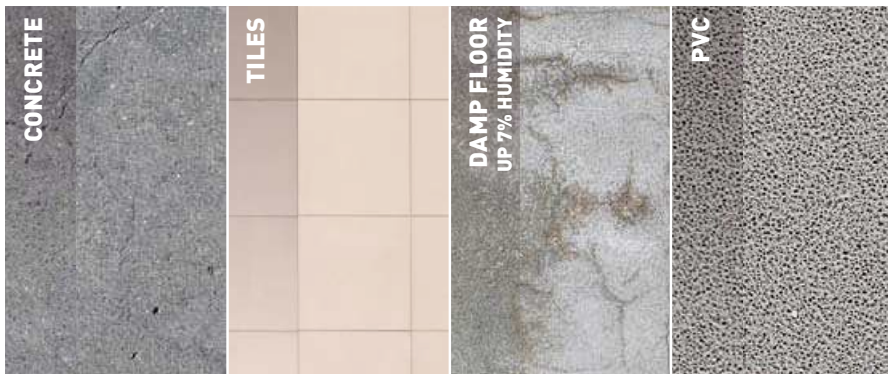

***For more information please refer to Gerflor's installation guidelines.*

EASY TO REPLACE



LUXURY VINYL TILE

CREATION 70 CLIC SYSTEM



▶ CREATION 70 CLIC SYSTEM

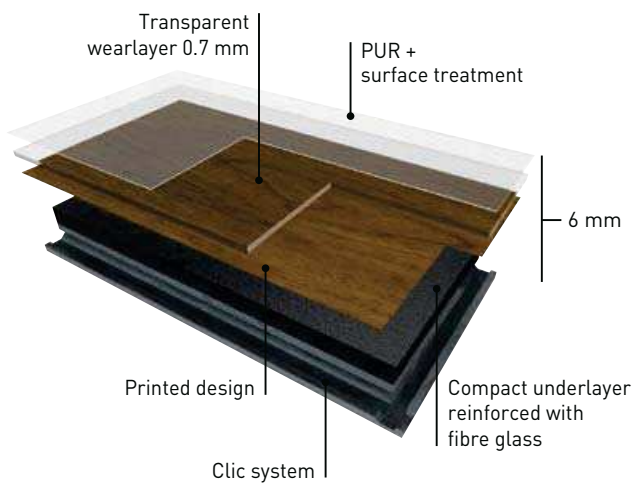

CREATION 70 CLIC SYSTEM is a synthetic, decorative, flexible, antistatic, abrasion group T floorcovering, available in planks 17.6x100cm, 20.4x123.9cm and tiles 36x69.6cm with bevelled edges.

It consists of a 0.7mm thick transparent wear layer, a design film, a reinforced compact underlayer. They are compressed and grained at high pressure.

CREATION 70 CLIC SYSTEM is treated with a polyurethane treatment **PUR+** providing excellent cleaning characteristics and improved resistance to scratching and chemicals. PUR+ significantly delays the application of wax.

The overall thickness is 6mm.

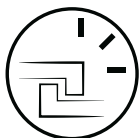

Possible installation on Gerflor underlayer for better sound insulation.

CREATION 70 CLIC SYSTEM



reddot award 2016
winner

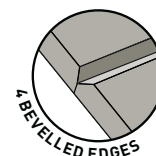

PUR+



100% recyclable

► The one installation solution

- Interlocking planks that can be laid without adhesive, with the benefit of easier installation and removal
- Rapid installation system by vertical clipping > simplified finishing (angles, pillar surrounds, etc...)
- Easy replacement of individual planks when required
- No need to close the premises, no loss of revenue
- Minimum sub-floor preparation
- Installation also possible on existing floor coverings

| DESCRIPTION | EN ISO 24346 (EN 428) | mm | CREATION 70 CLIC SYSTEM | CREATION 70 CLIC SYSTEM ACOUSTIC | |
|-----------------------------------------|--------------------------|---------------------|-------------------------------|----------------------------------|-------------------------------------------------|
| | | | | Gerflor Acoustic 15dB | Creation 70 Clic System + Gerflor Acoustic 15dB |
| Total thickness | EN ISO 24346 (EN 428) | mm | 6 | 0.93 | 6.93 |
| Thickness of wearlayer | EN ISO 24340 (EN 429) | mm | 0.70 | - | 0.70 |
| Weight | EN ISO 23997 (EN 430) | g/sq.m | 9895 | 200 | 10095 |
| Length of sheet | EN ISO 24341 (EN 426) | ml | - | 15 | - |
| Width of sheet | EN ISO 24341 (EN 426) | cm | - | 100 | - |
| Size | EN ISO 24342 (EN 427) | mm | 176x1000 / 204x1239 / 360x696 | - | 176x1000 / 204x1239 / 360x696 |
| CLASSIFICATION | | | | | |
| Norm / Product specification | - | - | EN ISO 10582 (EN 649) | - | - |
| European classification | EN ISO 10874 (EN 685) | class | 34-43 | - | 34-43 |
| Fire rating | EN 13501-1 | class | Bfl-s1 | Efl | Bfl-s1 |
| Static electrical propensity | EN 1815 | kV | < 2 | - | - |
| Slip resistance wet: ramp test with oil | DIN 51 130 | class | R9 / R10 ^[1] | - | R9 / R10 ^[1] |
| PERFORMANCES | | | | | |
| Wear resistance | EN 660.2 | mm ³ | ≤ 2.0 | - | ≤ 2.0 |
| Wear group | NF 189 | group | T | - | T |
| Type Binder content | ISO 10582 | type | I | - | I |
| Dimensional stability | EN ISO 23999 (EN 434) | % | ≤ 0.15 | - | ≤ 0.15 |
| Residual indentation | EN ISO 24343-1 (EN 433) | mm | ≤ 0.10 | 0.16 | 0.14 |
| Impact sound insulation | EN ISO 717-2 | dB | 5 | - | 15 |
| Room impact | NF S 31074 | dB | 72 | - | 72 |
| Castor chair test (type W) | ISO 4918 (EN 425) | - | OK | - | OK |
| Thermal conductivity | EN ISO 10456 (EN 12 524) | W/(m.k) | 0.25 | - | 0.25 |
| Colour fastness | EN 20 105 - B02 | degree | ≥ 6 | - | ≥ 6 |
| Surface treatment | - | - | PUR+ | - | PUR+ |
| Chemical products resistance | EN ISO 26987 (EN 423) | - | OK | - | OK |
| ENVIRONMENT / INDOOR AIR QUALITY | | | | | |
| TVOC after 28 days | ISO 16000-6 | µg / m ³ | <100 | - | <100 |
| Certification | - | - | Floorscore® | - | - |
| CE MARKING | | | | | |
| CE | EN 14041 | | | | |
| | | | | | |

[1] Slip resistance wet: details on website gerflor.com

LUXURY VINYL TILE

CREATION 70 CLIC SYSTEM



0337 Victoria Oak

17.6x100 cm



0335 Sycamore

17.6x100 cm



0258 Muir Oak

17.6x100 cm



0272 Sorb

17.6x100 cm



0260 Classic Oak

17.6x100 cm



0262 Elm

17.6x100 cm



0545 Serena

20.4x123.9 cm



0265 Walnut

17.6x100 cm



0360 Deep Forest

17.6x100 cm
20.4x123.9 cm



0541 Flamingo

20.4x123.9 cm



DESIGN SHADE VARIATION:



Light



Medium



High

CREATION 70 CLIC SYSTEM



reddot award 2016
winner

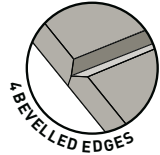

PUR+



100% recyclable



0324 Silversands

20.4x123.9 cm



0358 Moon Island

17.6x100 cm



0538 Midwest

20.4x123.9 cm



0577 Albion

20.4x123.9 cm



0359 Wild Oak

17.6x100 cm



Luxury Vinyl Tile

LUXURY VINYL TILE

CREATION 70 CLIC SYSTEM



0576 Ocean Side

20.4x123.9 cm



0565 Sheridan

20.4x123.9 cm



0356 Denim Wood

17.6x100 cm



0357 Portobello

17.6x100 cm
20.4x123.9 cm



0568 Fargo

20.4x123.9 cm



CREATION 70 CLIC SYSTEM



reddot award 2016
winner

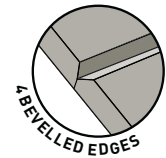

PUR+



100% recyclable



0414 Travertin Stone

36x69.6 cm

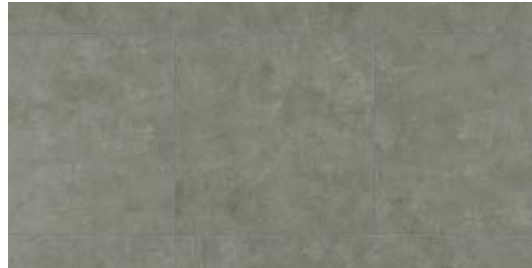

0522 East Village

36x69.6 cm

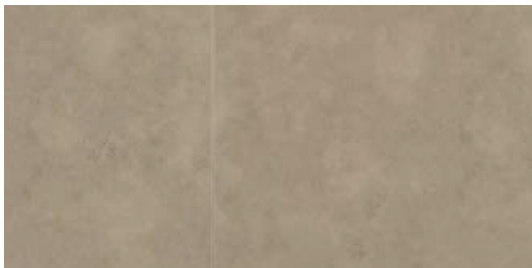

0528 Flagstaf

36x69.6 cm



0531 Halifax

36x69.6 cm



0087 Dock Taupe

36x69.6 cm



0529 Somerset

36x69.6 cm

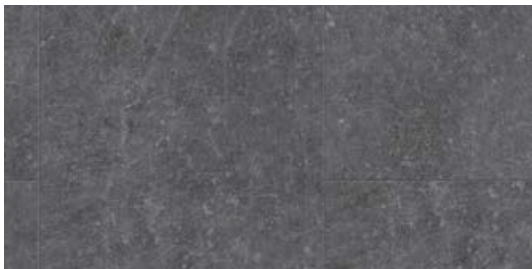

0085 Dock Grey

36x69.6 cm



0394 Welsh Slate

36x69.6 cm



Luxury Vinyl Tile

DESIGN SHADE VARIATION:



Light



Medium



High

LUXURY VINYL TILE

CREATION 70 X'PRESS

▶ CREATION 70 X'PRESS.....

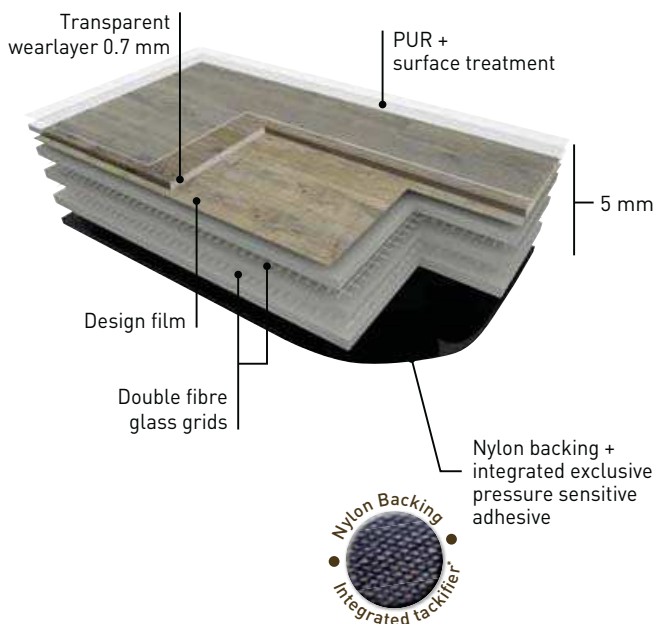

CREATION 70 X'PRESS is a synthetic, decorative, flexible, abrasion group T, available in tiles and planks with beveled edges. Composed of a transparent wear layer 0.7mm thick, a design film and three compact underlayers reinforced with two fiber grids, **CREATION 70 X'PRESS** is 5mm compact product. Compressed and embossed at high temperatures.

The product includes "Pressure Sensitive Adhesive" (PSA) on the nylon backing, specifically for high traffic use. Subfloor is clean after removal. The product is treated with a **PUR +** treatment for easy maintenance properties.

Product **CREATION 70 X'PRESS** is made with 83% of mineral and 6% inexhaustible materials. It does not contain formaldehyde, any heavy metals or substances CMR 1&2, vPvB (very persistent and very bioaccumulative) and PBT (persistent, bioaccumulative and toxic), and they are 100% compliant with REACH.

The product emission rate of volatile organic compounds is $<100\mu\text{g}/\text{m}^3$ (TVOC-28 days - ISO 16000-6) and is rated A + (the best class) as part of the health labeling. It is 100% recyclable.

**Exclusive "Pressure Sensitive Adhesive" (PSA) on clean subfloor*



CREATION 70 X'PRESS



reddot award 2016
winner

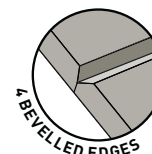
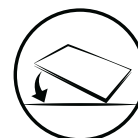

4 BEVELLED EDGES



PUR+



100% recyclable

► Ready to use:

- Looselay = Pressure Sensitive Adhesive (PSA) included on the backing, specifically for high traffic use
- Direct installation on existing subfloor (In compliance with GERFLOR's installation guidelines)
- Clean and quiet Installation for easy installation in busy areas

► Removable:

- No tools needed to remove floor
- Easy to replace a single plank/tile
- Subfloor is clean after removal*

► Easy :

- One tool required : a sharp blade
- Just press to install the product

* For more information please refer to Gerflor's guidelines.

CREATION 70 X'PRESS

| DESCRIPTION | | | |
|-----------------------------------------|--------------------------|---------------------|-----------------------------------|
| Total thickness | EN ISO 24346 [EN 428] | mm | 5.00 |
| Thickness of wearlayer | EN ISO 24340 [EN 429] | mm | 0.70 |
| Weight | EN ISO 23997 [EN 430] | g/sq.m | 8960 |
| Plank size | EN ISO 24342 [EN 427] | mm | 184 x 1219 |
| Tile size | EN ISO 24342 [EN 427] | mm | 610 x 610 / 457 x 914 / 500 x 500 |
| CLASSIFICATION | | | |
| Norm / Product specification | - | - | EN ISO 10582 [EN 649] |
| European classification | EN ISO 10874 [EN 685] | class | 34-43 |
| Fire rating | EN 13501-1 | class | Bfl-s1 |
| Static electrical propensity | EN 1815 | kV | < 2 |
| Slip resistance wet: ramp test with oil | DIN 51 130 | class | R9 / R10 / R11 ^[1] |
| PERFORMANCES | | | |
| Wear resistance | EN 660.2 | mm ³ | ≤ 2.0 |
| Wear group | NF 189 | group | T |
| Type Binder content | ISO 10582 | type | I |
| Room impact | NF S 31074 | dB | 72 |
| Impact sound insulation | EN ISO 717-2 | dB | 8 |
| Dimensional stability | EN ISO 23999 [EN 434] | % | ≤ 0.15 |
| Residual indentation | EN ISO 24343-1 [EN 433] | mm | ≤ 0.10 |
| Castor chair test (type W) | ISO 4918 [EN 425] | - | OK |
| Thermal conductivity | EN ISO 10456 [EN 12 524] | W/(m.k) | 0.25 |
| Colour fastness | EN 20 105 - B02 | degree | ≥ 6 |
| Surface treatment | - | - | PUR+ |
| Chemical products resistance | EN ISO 26987 [EN 423] | - | OK |
| ENVIRONMENT / INDOOR AIR QUALITY | | | |
| TVOC after 28 days | ISO 16000-6 | µg / m ³ | <100 |
| CE MARKING | | | |
| CE | EN 14041 | | |
| | | | |

[1] Slip resistance wet: details on website gerflor.com

LUXURY VINYL TILE

CREATION 70 X'PRESS



0538 Midwest

18.4 x 121.9 cm



0358 Moon Island

18.4 x 121.9 cm



0260 Classic Oak

18.4 x 121.9 cm



0360 Deep Forest

18.4 x 121.9 cm



0265 Walnut

18.4 x 121.9 cm



CREATION 70 X'PRESS



reddot award 2016
winner

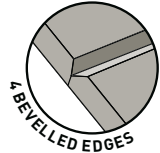
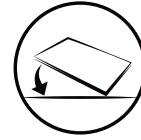

PUR+

100% recyclable



0356 Denim Wood

18.4 x 121.9 cm



0529 Somerset

61 x 61 cm



0357 Portobello

18.4 x 121.9 cm



0085 Dock Grey

45.7 x 91.4 cm



0087 Dock Taupe

45.7 x 91.4 cm



0088 Gentleman Grey

50 x 50 cm



0089 Gentleman Taupe

50 x 50 cm

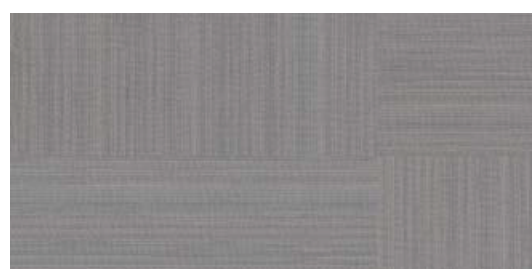

0021 Barma Sweet

50 x 50 cm

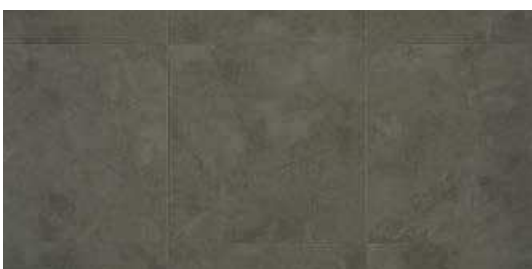

0531 Halifax

61 x 61 cm

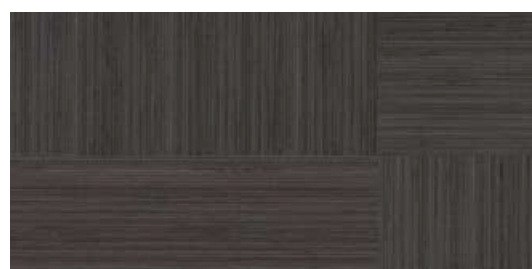

0023 Barma Mystery

50 x 50 cm



DESIGN SHADE VARIATION:



Light



Medium



High

Luxury Vinyl Tile

LUXURY VINYL TILE

CREATION 70

▶ EXCLUSIVE EMBOSSES FOR ENHANCED DESIGNS.....

HAMMERED

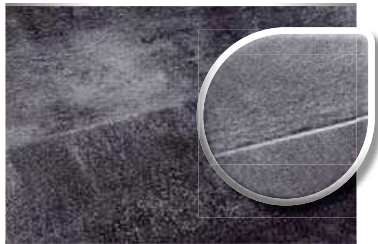

STONE



AUTHENTIC



SLATE



SAND



SAW EFFECT



PERFORATED

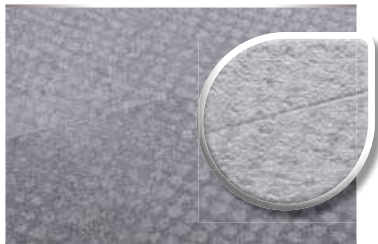

RIB WOOD



RAW



BRUSHED



NATURAL

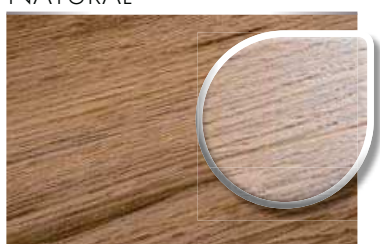

TEXTILE



LIGHT



RUSTIC WOOD

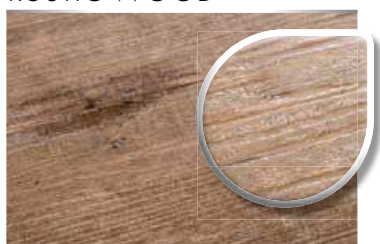

CREATION 70



CREATION 70 CREATION 70 CREATION 70



CLIC SYSTEM



X'PRESS







Code Slip Resistance wet (DIN 51130) / Embosses

| Code | Slip Resistance wet (DIN 51130) / Embosses | Slip Resistance wet (DIN 51130) / Embosses | Slip Resistance wet (DIN 51130) / Embosses |
|-----------------------|--------------------------------------------|--------------------------------------------|--------------------------------------------|
| CLASSIC OAK | 0260 | R9 - NATURAL | R9 - NATURAL |
| DEEP FOREST | 0360 | R10 - BRUSHED | R10 - BRUSHED |
| DENIM WOOD | 0356 | R9 - SAW EFFECT | R9 - HAMMERED LIGHT |
| DOCK GREY | 0085 | R10 - HAMMERED | R9 - HAMMERED LIGHT |
| DOCK TAUPE | 0087 | R10 - HAMMERED | R9 - HAMMERED LIGHT |
| HALIFAX | 0531 | R9 - STONE | R10 - HAMMERED |
| MIDWEST | 0538 | R9 - NATURAL | R9 - NATURAL |
| MOON ISLAND | 0358 | R10 - BRUSHED | R10 - BRUSHED |
| PORTOBELLO | 0357 | R10 - BRUSHED | R10 - BRUSHED |
| SOMERSET | 0529 | R11 - PERFORATED | R10 - HAMMERED |
| WALNUT | 0265 | R9 - NATURAL | R9 - NATURAL |
| ALBION | 0577 | R9 - NATURAL | R9 - NATURAL |
| EAST VILLAGE | 0522 | R9 - STONE | R10 - HAMMERED |
| ELM | 0262 | R9 - NATURAL | R9 - NATURAL |
| FARGO | 0568 | R9 - SAW EFFECT | R9 - HAMMERED LIGHT |
| FLAGSTAF | 0528 | R9 - STONE | R9 - HAMMERED LIGHT |
| FLAMINGO | 0541 | R9 - NATURAL | R9 - NATURAL |
| MUIR OAK | 0258 | R9 - NATURAL | R9 - NATURAL |
| OCEAN SIDE | 0576 | R9 - SAW EFFECT | R9 - HAMMERED LIGHT |
| SERENA | 0545 | R9 - NATURAL | R9 - NATURAL |
| SHERIDAN | 0565 | R10 - AUTHENTIC | R10 - BRUSHED |
| SILVER SANDS | 0324 | R9 - NATURAL | R9 - NATURAL |
| SORB | 0272 | R9 - NATURAL | R9 - NATURAL |
| SYCAMORE | 0335 | R9 - NATURAL | R9 - NATURAL |
| TRAVERTIN STONE | 0414 | R9 - SAND | R9 - HAMMERED LIGHT |
| VICTORIA OAK | 0337 | R9 - NATURAL | R9 - NATURAL |
| WELSH SLATE | 0394 | R10 - SLATE | R10 - HAMMERED |
| WILD OAK | 0359 | R10 - BRUSHED | R10 - BRUSHED |
| ABERDEEN | 0537 | R10 - BRUSHED | - |
| ATOK | 0525 | R9 - STONE | - |
| BAUTISTA | 0558 | R9 - SAW EFFECT | - |
| BEDGEBURY OAK | 0338 | R9 - NATURAL | - |
| BEVERLY | 0539 | R10 - BRUSHED | - |
| BLACK CREEK | 0540 | R10 - BRUSHED | - |
| BUXTON OAK | 0340 | R9 - NATURAL | - |
| CALABRIA | 0560 | R9 - SAW EFFECT | - |
| CARASSI | 0561 | R10 - RIB WOOD | - |
| CARRINGTON | 0572 | R10 - RUSTIC WOOD | - |
| CERVINO OAK BEIGE | 0797 | R9 - NATURAL | - |
| CERVINO OAK NATURE | 0798 | R9 - NATURAL | - |
| CLIFTON | 0556 | R9 - NATURAL | - |
| COBARGO | 0544 | R9 - NATURAL | - |
| COLOMBUS | 0554 | R9 - SAW EFFECT | - |
| DARK SLATE | 0114 | R10 - NATURAL | - |
| DOUGLAS | 0535 | R10 - BRUSHED | - |
| DUCHESS | 0547 | R9 - NATURAL | - |
| FAIRVIEW | 0566 | R9 - SAW EFFECT | - |
| FIDELIO | 0562 | R10 - RIB WOOD | - |
| GILMORE | 0557 | R9 - NATURAL | - |
| GREENWICH | 0402 | R10 - HAMMERED | - |
| HAMILTON | 0550 | R10 - BRUSHED | - |
| LAWSON | 0573 | R9 - SAW EFFECT | - |
| LEWIS TOWN | 0512 | R9 - STONE | - |
| LIMED OAK | 0329 | R9 - NATURAL | - |
| MARUTEA | 0570 | R9 - SAW EFFECT | - |
| MASSERIA | 0564 | R10 - RAW | - |
| OXYD PURE | 0088 | R11 - PERFORATED | - |
| OXYD IRON | 0089 | R11 - PERFORATED | - |
| RED SPIRIT | 0563 | R10 - RAW | - |
| REGIMENTAL NAVY BLUE | 0805 | R9 - NATURAL | - |
| REGIMENTAL PICADILLY | 0807 | R9 - NATURAL | - |
| REGIMENTAL SHERWOOD | 0808 | R9 - NATURAL | - |
| SOLID GLAM NAVY BLUE | 0801 | R9 - NATURAL | - |
| SOLID GLAM PICADILLY | 0803 | R9 - NATURAL | - |
| SOLID GLAM SHERWOOD | 0804 | R9 - NATURAL | - |
| SPENCER | 0575 | R9 - NATURAL | - |
| TANAMI | 0552 | R9 - LIGHT | - |
| TOASTED WOOD CAFE | 0799 | R9 - NATURAL | - |
| TOASTED WOOD ROADSTER | 0800 | R9 - NATURAL | - |
| WATERLAND | 0569 | R9 - SAW EFFECT | - |
| BARMA MYSTERY | 0023 | - | R9 - STONE |
| BARMA SWEET | 0021 | - | R9 - STONE |
| GENTLEMEN GREY | 0088 | - | R10 - TEXTILE |
| GENTLEMEN TAUPE | 0089 | - | R10 - TEXTILE |

LUXURY VINYL TILE

CREATION 70

| | Code |  CREATION 70 |  CREATION 70 CLIC SYSTEM |  CREATION 70 X'PRESS |  SKIRTING 100% Matching |
|-----------------------|------|-----------------------------------------------------------------------------------------------|-----------------------------------------------------------------------------------------------------------|-------------------------------------------------------------------------------------------------------|----------------------------------------------------------------------------------------------------------|
| CLASSIC OAK | 0260 | • | • | • | 0260 |
| DEEP FOREST | 0360 | • | • | • | 0360 |
| DENIM WOOD | 0356 | • | • | • | 0356 |
| DOCK GREY | 0085 | • | • | • | - |
| DOCK TAUPE | 0087 | • | • | • | - |
| HALIFAX | 0531 | • | • | • | - |
| MIDWEST | 0538 | • | • | • | 0504 |
| MOON ISLAND | 0358 | • | • | • | 0358 |
| PORTOBELLO | 0357 | • | • | • | 0357 |
| SOMERSET | 0529 | • | • | • | 0476 |
| WALNUT | 0265 | • | • | • | 0265 |
| ALBION | 0577 | • | • | - | - |
| EAST VILLAGE | 0522 | • | • | - | - |
| ELM | 0262 | • | • | - | 0262 |
| FARGO | 0568 | • | • | - | - |
| FLAGSTAF | 0528 | • | • | - | - |
| FLAMINGO | 0541 | • | • | - | 0528 |
| MUIR OAK | 0258 | • | • | - | 0258 |
| OCEAN SIDE | 0576 | • | • | - | 0576 |
| SERENA | 0545 | • | • | - | - |
| SHERIDAN | 0565 | • | • | - | - |
| SILVERSANDS | 0324 | • | • | - | - |
| SORB | 0272 | • | • | - | 0272 |
| SYCAMORE | 0335 | • | • | - | 0335 |
| TRAVERTIN STONE | 0414 | • | • | - | 0414 |
| VICTORIA OAK | 0337 | • | • | - | 0337 |
| WELSH SLATE | 0394 | • | • | - | - |
| WILD OAK | 0359 | • | • | - | 0359 |
| ABERDEEN | 0537 | • | - | - | - |
| ATOK | 0525 | • | - | - | - |
| BAUTISTA | 0558 | • | - | - | - |
| BEDGEBURY OAK | 0338 | • | - | - | - |
| BEVERLY | 0539 | • | - | - | - |
| BLACK CREEK | 0540 | • | - | - | - |
| BUXTON OAK | 0340 | • | - | - | - |
| CALABRIA | 0560 | • | - | - | - |
| CARASSI | 0561 | • | - | - | - |
| CARRINGTON | 0572 | • | - | - | - |
| CERVINO OAK BEIGE | 0797 | • | - | - | 0797 |
| CERVINO OAK NATURE | 0798 | • | - | - | 0798 |
| CLIFTON | 0556 | • | - | - | - |
| COBARGO | 0544 | • | - | - | - |
| COLOMBUS | 0554 | • | - | - | - |
| DARK SLATE | 0114 | • | - | - | - |
| DOUGLAS | 0535 | • | - | - | - |
| DUCHESS | 0547 | • | - | - | - |
| FAIRVIEW | 0566 | • | - | - | - |
| FIDELIO | 0562 | • | - | - | - |
| GILMORE | 0557 | • | - | - | - |
| GREENWICH | 0402 | • | - | - | - |
| HAMILTON | 0550 | • | - | - | - |
| LAWSON | 0573 | • | - | - | - |
| LEWIS TOWN | 0512 | • | - | - | - |
| LIMED OAK | 0329 | • | - | - | - |
| MARUTEA | 0570 | • | - | - | - |
| MASSERIA | 0564 | • | - | - | - |
| OXYD PURE | 0088 | • | - | - | 0088 |
| OXYD IRON | 0089 | • | - | - | 0089 |
| RED SPIRIT | 0563 | • | - | - | - |
| REGIMENTAL NAVY BLUE | 0805 | • | - | - | 0801 |
| REGIMENTAL PICADILLY | 0807 | • | - | - | 0803 |
| REGIMENTAL SHERWOOD | 0808 | • | - | - | 0804 |
| SOLID GIAM NAVY BLUE | 0801 | • | - | - | 0801 |
| SOLID GIAM PICADILLY | 0803 | • | - | - | 0803 |
| SOLID GIAM SHERWOOD | 0804 | • | - | - | 0804 |
| SPENCER | 0575 | • | - | - | - |
| TANAMI | 0552 | • | - | - | - |
| TOASTED WOOD CAFE | 0799 | • | - | - | 0799 |
| TOASTED WOOD ROADSTER | 0800 | • | - | - | 0800 |
| WATERLAND | 0569 | • | - | - | - |
| BARMA MYSTERY | 0023 | - | - | • | - |
| BARMA SWEET | 0021 | - | - | • | - |
| GENTLEMEN GREY | 0088 | - | - | • | - |
| GENTLEMEN TAUPE | 0089 | - | - | • | - |

• : Available

PACKAGING

| Product size (cm) | m ² / box | m ² / palette |
|--------------------------------|----------------------|--------------------------|
| CREATION 70 | | |
| 10.1 x 91.4 ⁽¹⁾ | 3.34 | 240.48 |
| 15.2 x 91.4 ⁽¹⁾ | 3.34 | 257.18 |
| 15.2 x 91.4 | 3.34 | 220.44 |
| 18.4 x 121.9 | 3.37 | 252.75 |
| 23 x 150 | 2.80 | 198.72 |
| Mix: 15.2/7.6/22.8 x 91.4 | 3.34 | 213.76 |
| 18.4 x 137.1 | 3.03 | 242.40 |
| 22.8 x 91.4 | 3.34 | 213.76 |
| 45.7 x 91.4 | 3.34 | 213.76 |
| 30.5 x 61 ⁽²⁾ | 3.72 | 133.92 |
| 61 x 61 | 3.34 | 160.32 |
| 30.5 x 61 | 3.34 | 140.28 |
| 45.7 x 45.7 | 3.34 | 213.76 |
| CREATION 70 CLIC SYSTEM | | |
| 17.6 x 100 | 1.40 | 78.40 |
| 36 x 69.6 | 1.50 | 81.20 |
| 20.4 x 123.9 | 1.52 | 97.06 |
| CREATION 70 X'PRESS | | |
| 18.4 x 121.9 | 1.35 | 114.75 |
| 61 x 61 | 1.49 | 80.46 |
| 45.7 x 91.4 | 1.67 | 73.48 |
| 50 x 50 | 1.50 | 102.00 |

(1) Silversands / Classic Oak / Muir Oak / Limed Oak / Elm / Bedgebury Oak / Sorb / Sycamore / Walnut / Buxton Oak / Denim Wood / Victoria Oak / Moon Island / Wild Oak / Portobello / Deep Forest / Douglas / Aberdeen / Serena / Duchess.

(2) Slate

CREATION 70



reddot award 2016
winner

▶ DECOR SKIRTING

To be installed with clip (5935) or mastic adhesive.

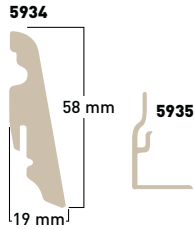

PACKAGING
5934: 5 x 2.4 lm / package
5935: 30 clip / package



▶ CREATION 70 WOOD: 15 matching decors



▶ CREATION 70 MINERAL: 9 decors

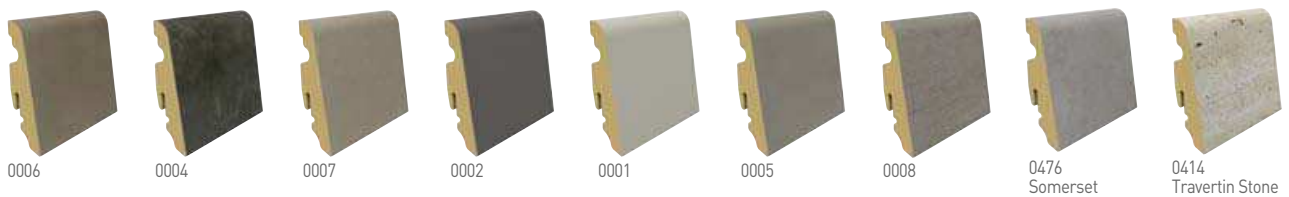

▶ ALUMINIUM PROFILES

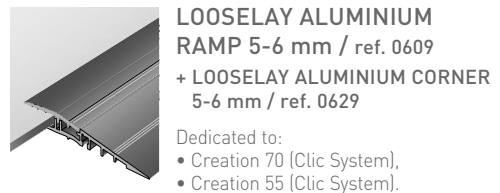
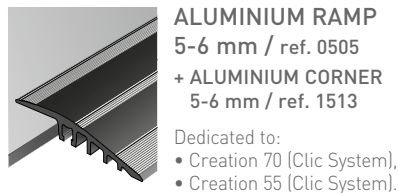

For further details see page 283

New

CREATION 55

EXCLUSIVE EDITION

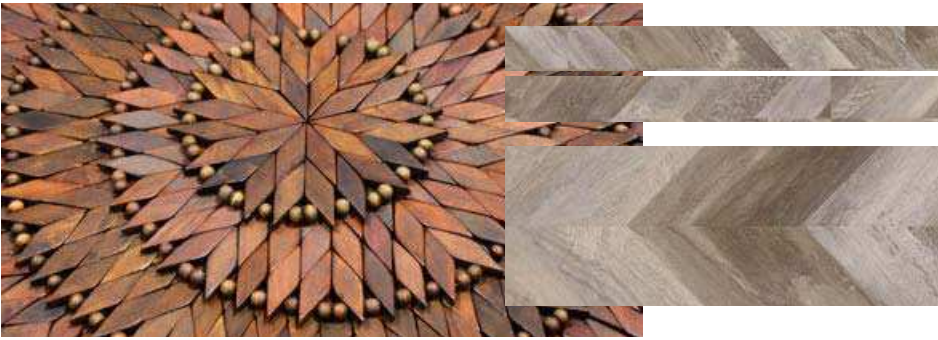

LUXURY VINYL TILE

CREATION 55 **EXCLUSIVE EDITION** **New**



PUR+

100% recyclable



CREATION 55 **EXCLUSIVE EDITION** New

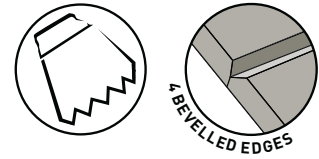

Compact |
 Compact |
 PUR+ |
 100% recyclable



0810 Chevron Moka 18.4x121.9 cm



0809 Chevron Hurricane 18.4x121.9 cm



0811 Chevron Buckwheat 18.4x121.9 cm



0817 North Wood Mokaccino 18.4x121.9 cm



0816 North Wood Macchiato 18.4x121.9 cm

Luxury Vinyl Tile

DESIGN SHADE VARIATION: Light Medium High

LUXURY VINYL TILE

CREATION 55 **EXCLUSIVE EDITION** **New**



PUR+

100% recyclable



CREATION 55 **EXCLUSIVE EDITION** New

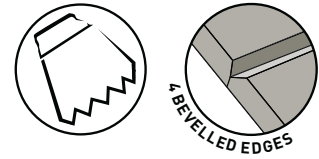

0795 Swiss Oak Cashmere 23x150 cm



0796 Swiss Oak Golden 23x150 cm



0815 Bostonian Oak Honey 18.4x121.9 cm



0814 Bostonian Oak Gold 18.4x121.9 cm



0812 Royal Oak Blond 18.4x121.9 cm



0740 Royal Oak Coffee 18.4x121.9 cm



0095 Rust Corten 45.7x91.4 cm



0094 Rust Metal 45.7x91.4 cm

Luxury Vinyl Tile

DESIGN SHADE VARIATION:  Light  Medium  High

LUXURY VINYL TILE

CREATION 55

▶ CREATION 55.....

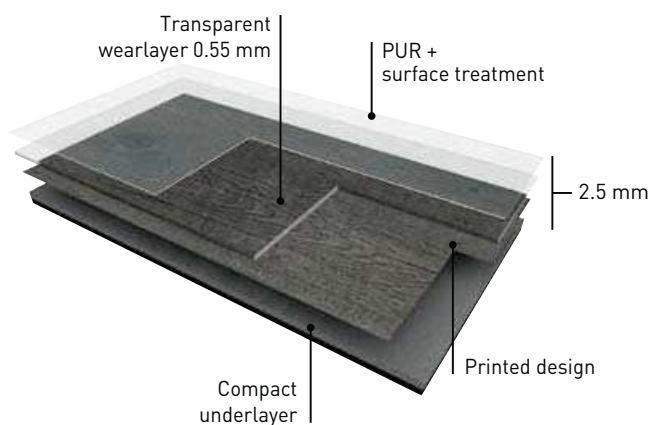

CREATION 55 are synthetic, decorative, flexible, antistatic, abrasion group T floorcoverings available in tile or plank forms, with bevelled edges.

They comprise a transparent wearlayer 0.55 mm thick, a design film and a compact underlayer. They are compressed and grained at high pressure.

CREATION 55 are treated with a polyurethane treatment **PUR+** providing excellent cleaning characteristics and improved resistance to scratching and chemicals. PUR+ significantly delays the application of wax.

Their overall thickness is 2.5mm.

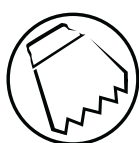

CREATION 55

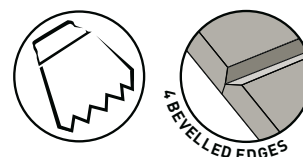

- ▶ **CREATION 55** is designed for medium and high traffic wear.
- ▶ A large pallet of Wood and Mineral designs.
- ▶ Low maintenance due to Polyurethane surface treatment **PUR+**.
- ▶ Plank with large format: Long Effect.

| | | | CREATION 55 |
|----------------------------------|--------------------------|---------------------|----------------------------------------------------------------------------------------------------------------------------------------------------------|
| | | | DESIGN |
| DESCRIPTION | | | |
| Total thickness | EN ISO 24346 (EN 428) | mm | 2.50 |
| Thickness of wearlayer | EN ISO 24340 (EN 429) | mm | 0.55 |
| Weight | EN ISO 23997 (EN 430) | g/sq.m | 4410 |
| Size | EN ISO 24342 (EN 427) | mm | Plank - 184x1371 / 184x1219 / 152x914 / 230x1500 Tile - 457x914 / 610x610 / 305x610 Creation Mix: 152 x 914 / 228 x 914 / 76 x 914 |
| CLASSIFICATION | | | |
| Norm / Product specification | - | - | EN ISO 10582 (EN 649) |
| European classification | EN ISO 10874 (EN 685) | class | 33-42 |
| Fire rating | EN 13501-1 | class | B _{fl} -s1 |
| Static electrical propensity | EN 1815 | kV | < 2 |
| Slip resistance wet | DIN 51 130 | class | R9 / R10 / R11 ^[1] |
| PERFORMANCES | | | |
| Wear resistance | EN 660.2 | mm ³ | ≤ 2.0 |
| Wear group | NF 189 | group | T |
| Type Binder content | ISO 10582 | type | I |
| Room impact | NF S 31074 | dB | 76 |
| Impact sound insulation | EN ISO 717-2 | dB | 4 |
| Dimensional stability | EN ISO 23999 (EN 434) | % | ≤ 0.15 |
| Residual indentation | EN ISO 24343-1 (EN 433) | mm | ≤ 0.10 |
| Castor chair test (type W) | ISO 4918 (EN 425) | - | OK |
| Thermal conductivity | EN ISO 10456 (EN 12 524) | W/(m.k) | 0.25 |
| Colour fastness | EN 20 105 - B02 | degree | ≥ 6 |
| Surface treatment | - | - | PUR+ |
| Chemical products resistance | EN ISO 26987 (EN 423) | - | OK |
| ENVIRONMENT / INDOOR AIR QUALITY | | | |
| TVOC after 28 days | ISO 16000-6 | µg / m ³ | <100 |
| CE MARKING | | | |
| CE | EN 14041 | | |
| | | | |

[1] Slip resistance wet: details on website gerflor.com

LUXURY VINYL TILE

CREATION 55



0070 Elegant Oak

15.2x91.4 cm



0449 Natural Cherry

15.2x91.4 cm



0442 Millington Oak

15.2x91.4 cm



0462 Eastern Oak

15.2x91.4 cm



0461 Michigan

15.2x91.4 cm



0463 Fudge

15.2x91.4 cm



0386 Pasadena

Creation 55 Mix
15.2x91.4 cm / 7.6x91.4 cm / 22.8x91.4 cm



0459 Brownie

15.2x91.4 cm



CREATION 55

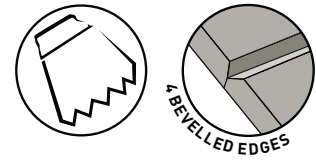

Compact | Compact | PUR+ | 100% recyclable



0465 Cambridge

15.2x91.4 cm



0347 Ballerina

15.2x91.4 cm



0464 Picadilly

15.2x91.4 cm



0578 Alisier

18.4x121.9 cm



Luxury Vinyl Tile

DESIGN SHADE VARIATION:



Light



Medium



High

LUXURY VINYL TILE

CREATION 55



Compact



Compact

PUR+



100% recyclable



0441 Honey Oak

15.2x91.4 cm



0455 Long Board

15.2x91.4 cm
18.4x121.9 cm



0488 Caldwell

15.2x91.4 cm



0503 Quartet

15.2x91.4 cm



CREATION 55

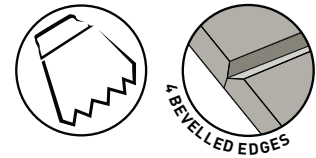

 Compact
  Compact
 | PUR+
  100% recyclable



0445 Rustic Oak 15.2x91.4 cm



0069 Mansfield Natural 18.4x121.9 cm



0425 Britany Oak 18.4x121.9 cm



0071 Solero Creme 18.4x137.1 cm



0579 Amarante 18.4x121.9 cm



0504 Twist 18.4x121.9 cm



0457 Buffalo 15.2x91.4 cm



0060 Arena 18.4x121.9 cm



DESIGN SHADE VARIATION:  Light  Medium  High

LUXURY VINYL TILE

CREATION 55



0489 Morena

18.4x121.9 cm



0584 White Lime

18.4x121.9 cm



0068 Mansfield Light

18.4x121.9 cm



0582 Deer

18.4x121.9 cm



CREATION 55

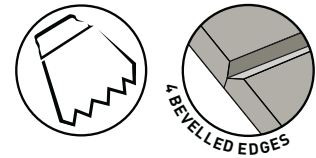

 Compact
  Compact
 | PUR+
  100% recyclable



0073 Spicy Brown

18.4x137.1 cm



0426 Vintage Oak

18.4x121.9 cm



0061 Oxford

18.4x121.9 cm



0583 Deep Oak

18.4x121.9 cm



0064 Gravity Dark

18.4x121.9 cm



0042 Mansfield Dark

18.4x137.1 cm



0065 Gravity Wood

18.4x121.9 cm



0458 Aspen

15.2x91.4 cm
18.4x121.9 cm



Luxury Vinyl Tile

DESIGN SHADE VARIATION:  Light  Medium  High

LUXURY VINYL TILE

CREATION 55



0448 Malua Bay

15.2x91.4 cm
18.4x121.9 cm



0581 Arya

18.4x121.9 cm



0456 Ranch

15.2x91.4 cm
18.4x121.9 cm



0067 Mahe Grey

18.4x121.9 cm



0446 Lorenzo

15.2x91.4 cm



0066 Mahe

18.4x121.9 cm



0447 Amador

15.2x91.4 cm



0072 Spicy Grey Blue

18.4x137.1 cm



DESIGN SHADE VARIATION:



Light



Medium



High

CREATION 55

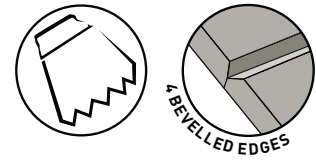

Compact



Compact

PUR+

100% recyclable



0062 Eramosa Gold

18.4x121.9 cm
45.7x91.4 cm



0063 Eramosa Creme

18.4x121.9 cm
45.7x91.4 cm



0618 Carmel

30.5x61 cm



0373 Silver City

61x61 cm



Luxury Vinyl Tile

LUXURY VINYL TILE

CREATION 55

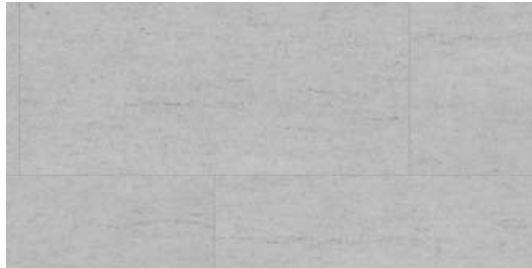

0966 Lava Light

45.7x91.4 cm



0048 Rockaway

30.5x61 cm



0620 Preston

61x61 cm

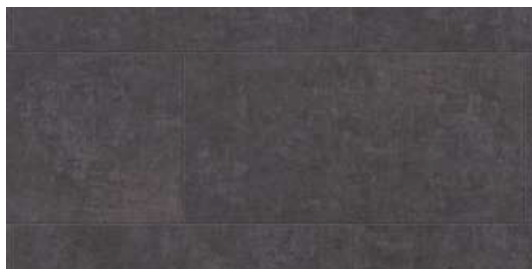

0487 Factory

30.5x61 cm



0374 Parker Station

61x61 cm



CREATION 55

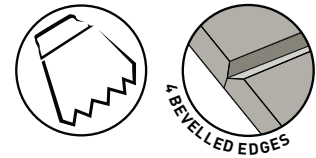

Compact
 Compact
 PUR+
 100% recyclable



0045 Moma 30.5x61 cm



0500 Anathema 30.5x61 cm



0476 Staccato 61x61 cm



0964 Roxbury 30.5x61 cm

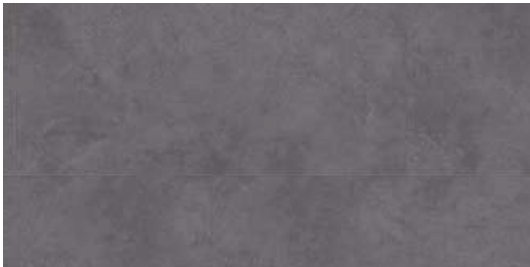

0436 Riverside 61x61 cm



0437 Sweet Cloud 61x61 cm



0438 Norwegian Slate 30.5x61 cm

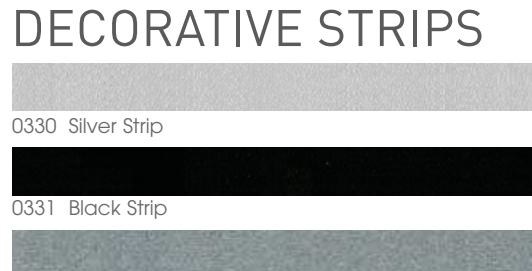

0330 Silver Strip



0331 Black Strip



0332 Light Concrete Strip



0333 Dark Concrete Strip



0334 Brown Concrete Strip



0335 White Concrete Strip

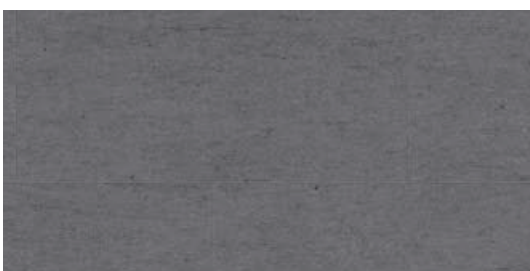

0967 Lava Grey 45.7x91.4 cm



| SIZE | PACKAGING | CODE |
|------------------|-------------------|------|
| Strip 4 x 914 mm | 1 pack = 80 units | 3203 |

DESIGN SHADE VARIATION:



Light



Medium



High

CREATION CLIC (R)EVOLUTION

**EXCLUSIVE
VERTICAL CLIC**

NO ADHESIVE



**+EASY
+FAST
+QUIET**

NEW TOOL:
THE PRESSURE ROLLER

+RESISTANT

HIGH RESISTANCE
TO VERTICAL FORCE
AND TO HEAVY TRAFFIC



INSTALLATION ON GERFLOR ACOUSTIC UNDERLAY:

▶ BETTER IMPACT SOUND INSULATION



INSTALL DIRECTLY ON ANY SUBFLOOR**

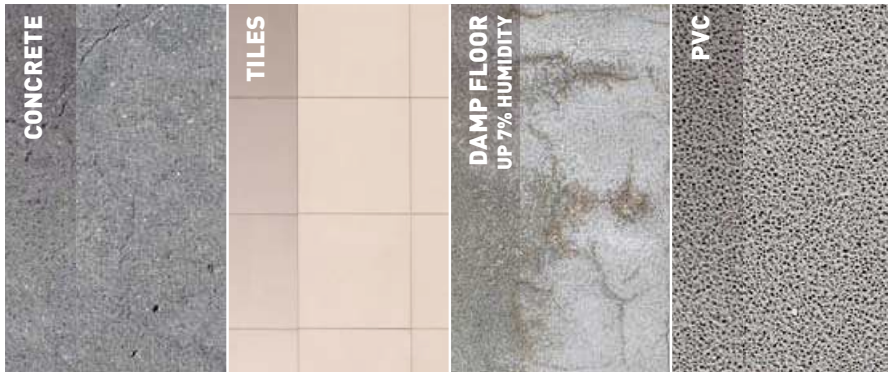

***For more information please refer to Gerflor's installation guidelines.*

EASY TO REPLACE



LUXURY VINYL TILE

CREATION 55 CLIC SYSTEM



▶ CREATION 55 CLIC SYSTEM

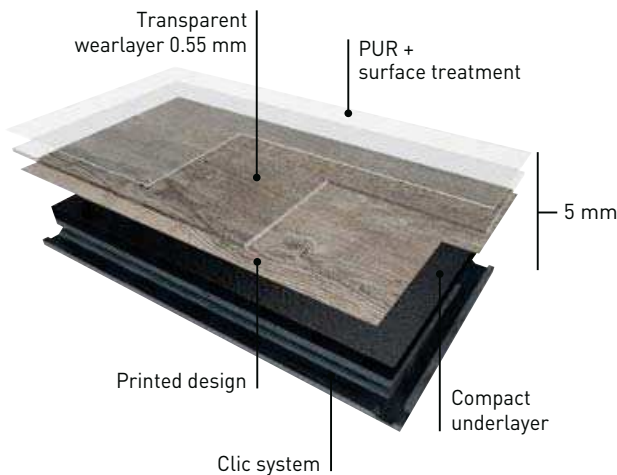

CREATION 55 CLIC SYSTEM is a synthetic, decorative, flexible, antistatic, abrasion group T floorcovering, available in planks 17.6x100cm, 20.4x123.9cm and tiles 36x69.6cm with bevelled edges.

It consists of a 0.55mm thick transparent wear layer, a design film, a reinforced compact underlayer. They are compressed and grained at high pressure.

CREATION 55 CLIC SYSTEM is treated with a polyurethane treatment **PUR+** providing excellent cleaning characteristics and improved resistance to scratching and chemicals. PUR+ surface treatment significantly delays the application of wax.

The overall thickness is 5mm.



Possible installation on Gerflor underlayer for better sound insulation.

CREATION 55 CLIC SYSTEM

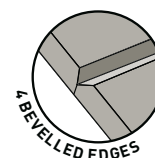

► The one installation solution

- Interlocking planks and tiles which can be laid without adhesive, with the benefit of easier installation and removal
- Rapid installation system by vertical clipping > simplified finishing (angles, pillar surrounds, etc...)
- Easy replacement of individual planks and tiles when required
- No need to close the premises, no loss of revenue
- Minimum sub-floor preparation
- Installation also possible on existing floor coverings

| | CREATION 55 CLIC SYSTEM | | | CREATION 55 CLIC SYSTEM ACOUSTIC | |
|-----------------------------------------|--------------------------|---------------------|-------------------------------|----------------------------------|-------------------------------------------------|
| | | | | Gerflor Acoustic 15dB | Creation 55 Clic System + Gerflor Acoustic 15dB |
| DESCRIPTION | | | | | |
| Total thickness | EN ISO 24346 (EN 428) | mm | 5.00 | 0.93 | 5.93 |
| Thickness of wearlayer | EN ISO 24340 (EN 429) | mm | 0.55 | - | 0.55 |
| Weight | EN ISO 23997 (EN 430) | g/sq.m | 8260 | 200 | 8460 |
| Plank size | EN ISO 24342 (EN 427) | mm | 176 x 1000 / 204x1239 | - | 176 x 1000 / 204x1239 |
| Tile size | EN ISO 24342 (EN 427) | mm | 360 x 696 | - | 360 x 696 |
| Length of sheet | EN ISO 24341 (EN 426) | m | - | 15 | - |
| Width of sheet | EN ISO 24341 (EN 426) | cm | - | 100 | - |
| CLASSIFICATION | | | | | |
| Norm / Product specification | - | - | EN ISO 10582 (EN 649) | - | - |
| European classification | EN ISO 10874 (EN 685) | class | 33-42 | - | 33-42 |
| Fire rating | EN 13501-1 | class | Bfl-s1 | Efl | Bfl-s1 |
| Static electrical propensity | EN 1815 | kV | < 2 | - | - |
| Slip resistance wet: ramp test with oil | DIN 51 130 | class | R9 / R10 / R11 ^[1] | - | R9-R10 ^[1] |
| PERFORMANCES | | | | | |
| Wear resistance | EN 660.2 | mm ³ | < 2.0 | - | ≤ 2.0 |
| Wear group | NF 189 | group | T | - | T |
| Type Binder content | ISO 10582 | type | I | - | I |
| Room impact | NF S 31074 | dB | 73 | - | 70 |
| Impact sound insulation | EN ISO 717-2 | dB | 5 | - | 15 |
| Dimensional stability | EN ISO 23999 (EN 434) | % | ≤ 0.15 | - | ≤ 0.15 |
| Residual indentation | EN ISO 24343-1 (EN 433) | mm | ≤ 0.10 | 0.16 | 0.13 |
| Castor chair test (type W) | ISO 4918 (EN 425) | - | OK | - | OK |
| Thermal conductivity | EN ISO 10456 (EN 12 524) | W/(m.k) | 0.25 | - | - |
| Colour fastness | EN 20 105 - B02 | degree | ≥ 6 | - | ≥ 6 |
| Surface treatment | - | - | PUR+ | - | PUR+ |
| Chemical products resistance | EN 423 | - | OK | - | OK |
| ENVIRONMENT / INDOOR AIR QUALITY | | | | | |
| TVOC after 28 days | ISO 16000-6 | µg / m ³ | <100 | - | <100 |
| Certification | - | - | Floorscore® | - | - |
| CE MARKING | | | | | |
| CE | EN 14041 | | | | |
| | | | | | |

[1] Slip resistance wet: details on website gerflor.com

LUXURY VINYL TILE

CREATION 55 CLIC SYSTEM

Compact Compact PUR+ 100% recyclable



0489 Morena

17.6x100 cm



0071 Solero Creme

20.4x123.9 cm



0455 Long Board

20.4x123.9 cm



0488 Caldwell

17.6x100 cm



0503 Quartet

20.4x123.9 cm



CREATION 55 CLIC SYSTEM

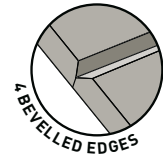

PUR+



100% recyclable



0448 Malua Bay

17.6x100 cm



0465 Cambridge

17.6x100 cm



0504 Twist

20.4x123.9 cm



0464 Picadilly

17.6x100 cm



0579 Amarante

20.4x123.9 cm



0347 Ballerina

20.4x123.9 cm



0445 Rustic Oak

17.6x100 cm



0578 Alisier

20.4x123.9 cm



0457 Buffalo

17.6x100 cm



0459 Brownie

17.6x100 cm



DESIGN SHADE VARIATION:



Light



Medium



High

Luxury Vinyl Tile

LUXURY VINYL TILE

CREATION 55 CLIC SYSTEM

  **PUR+**  100% recyclable



0462 Eastern oak

17.6x100 cm



0442 Milington oak

17.6x100 cm



0441 Honey Oak

17.6x100 cm



0461 Michigan

17.6x100 cm



0386 Pasadena

17.6x100 cm



CREATION 55 CLIC SYSTEM

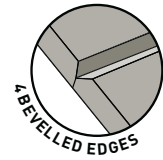

PUR+



100% recyclable



0446 Lorenzo

17.6x100 cm



0584 White Lime

20.4x123.9 cm



0456 Ranch

17.6x100
20.4x123.9 cm



0060 Arena

20.4x123.9 cm



0447 Amador

17.6x100
20.4x123.9 cm



0582 Deer

20.4x123.9 cm



0042 Mansfield Dark

20.4x123.9 cm



0061 Oxford

20.4x123.9 cm



0458 Aspen

17.6x100 cm



0583 Deep Oak

20.4x123.9 cm



DESIGN SHADE VARIATION:



Light



Medium



High



LUXURY VINYL TILE

CREATION 55 CLIC SYSTEM

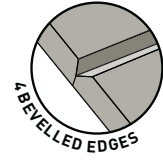

PUR+



100% recyclable



0964 Roxbury

36 x 69.6 cm



0966 Lava Light

36 x 69.6 cm



0618 Carmel

36 x 69.6 cm



0967 Lava Grey

36 x 69.6 cm



0373 Silver City

36 x 69.6 cm



0620 Preston

36 x 69.6 cm

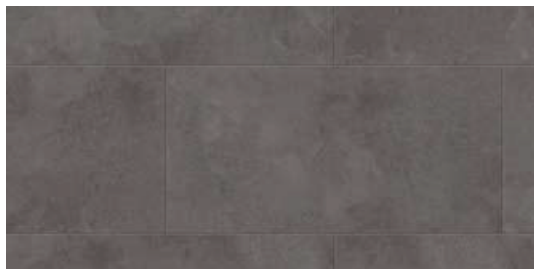

0436 Riverside

36 x 69.6 cm



0438 Norwegian Slate

36 x 69.6 cm



0374 Parker Station

36 x 69.6 cm



DESIGN SHADE VARIATION:



Light



Medium



High

Luxury Vinyl Tile

LUXURY VINYL TILE

CREATION 55 X'PRESS

▶ CREATION 55 X'PRESS

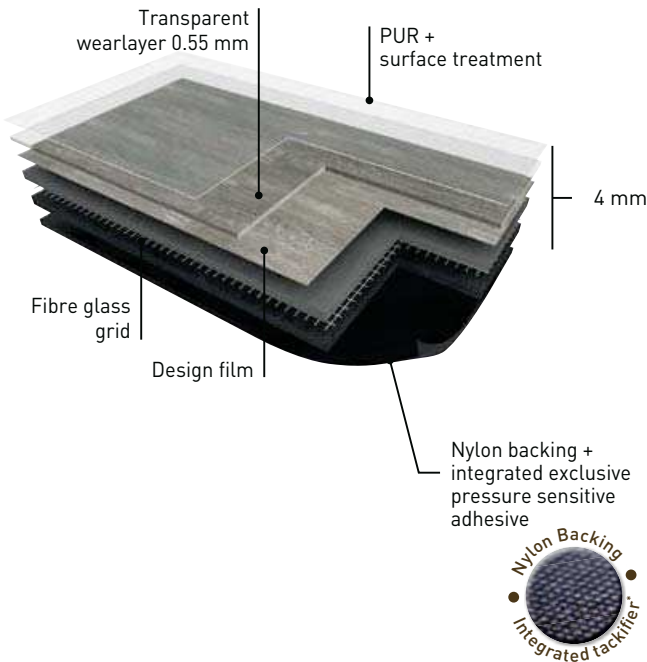

CREATION 55 X'PRESS is a synthetic, decorative, flexible, abrasion group T product available in tiles and planks with beveled edges. It comprises a 0,55mm thick transparent wear layer.

It is a 4mm compact product, compressed and grained at high pressure, made with a design film, two compact underlayers reinforced with a fibre grid. The product includes "Pressure Sensitive Adhesive" (PSA) on the nylon backing, specifically for high traffic use. Subfloor is clean after removal.

CREATION 55 X'PRESS is treated with a **PUR+** treatment for easy maintenance properties.

CREATION 55 X'PRESS is made with 73% of mineral and 12% inexhaustible materials. It is made with 100% control recycled materials. It is 100% compliant with REACH. The product emission rate of organic compounds is $< 100\mu\text{g}/\text{m}^3$ (TVOC < 28 days - ISO 16000-6). It is 100% recyclable.

*Exclusive "Pressure Sensitive Adhesive" (PSA) on clean subfloor



CREATION 55 X'PRESS

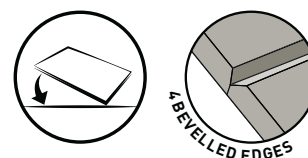

► **Ready to use:**

- Looselay = Pressure Sensitive Adhesive (PSA) included on the backing of the product
- Direct installation on existing subfloor (In compliance with Gerflor's installation guidelines)
- Clean and quiet for easy installation in busy areas

► **Removable:**

- No tools needed to remove floor
- Easy to replace a single plank/tile
- Subfloor is clean after removal*

► **Easy:**

- One tool required: a sharp blade
- Just press to install the product

* For more information please refer to Gerflor's guidelines.

CREATION 55 X'PRESS

| DESCRIPTION | | | |
|-----------------------------------------|--------------------------|---------------------|-------------------------------|
| Total thickness | EN ISO 24346 (EN 428) | mm | 4.00 |
| Thickness of wearlayer | EN ISO 24340 (EN 429) | mm | 0.55 |
| Weight | EN ISO 23997 (EN 430) | g/sq.m | 7200 |
| Plank size | EN ISO 24342 (EN 427) | mm | 184 x 1219 |
| Tile size | EN ISO 24342 (EN 427) | mm | 305 x 610 |
| CLASSIFICATION | | | |
| Norm / Product specification | - | - | EN ISO 10582 (EN 649) |
| European classification | EN ISO 10874 (EN 685) | class | 33-42 |
| Fire rating | EN 13501-1 | class | Bfl-s1 |
| Static electrical propensity | EN 1815 | kV | < 2 |
| Slip resistance wet: ramp test with oil | DIN 51 130 | class | R9 / R10 / R11 ⁽¹⁾ |
| PERFORMANCES | | | |
| Wear resistance | EN 660.2 | mm ³ | ≤ 2.0 |
| Wear group | NF 189 | group | T |
| Type Binder content | ISO 10582 | type | I |
| Room impact | NF S 31074 | dB | 74 |
| Room sound insulation | EN ISO 717-2 | dB | 5 |
| Dimensional stability | EN ISO 23999 (EN 434) | % | ≤ 0.15 |
| Residual indentation | EN ISO 24343-1 (EN 433) | mm | ≤ 0.10 |
| Castor chair test (type W) | ISO 4918 (EN 425) | - | OK |
| Thermal conductivity | EN ISO 10456 (EN 12 524) | W/(m.k) | 0.25 |
| Colour fastness | EN 20 105 - B02 | degree | ≥ 6 |
| Surface treatment | - | - | PUR+ |
| Chemical products resistance | EN ISO 26987 (EN 423) | - | OK |
| ENVIRONMENT / INDOOR AIR QUALITY | | | |
| TVOC after 28 days | ISO 16000-6 | µg / m ³ | <100 |
| CE MARKING | | | |
| CE | EN 14041 | | |
| | | | |

LUXURY VINYL TILE

CREATION 55 X'PRESS



0500 Anathema

30.5 x 61 cm



0578 Alisier

18.4 x 121.9 cm



0579 Amarante

18.4 x 121.9 cm



0456 Ranch

18.4 x 121.9 cm



CREATION 55 X'PRESS

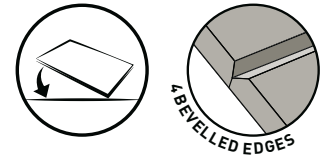

 Compact
  Compact
 PUR+
 100% recyclable



0584 White Lime 18.4 x 121.9 cm



0447 Amador 18.4 x 121.9 cm

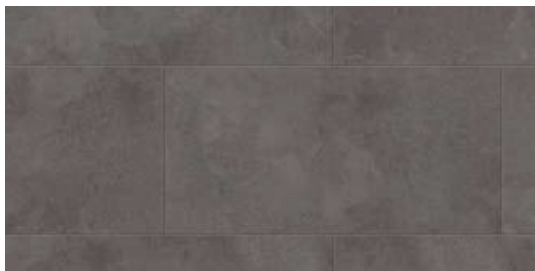

0436 Riverside 30.5 x 61 cm

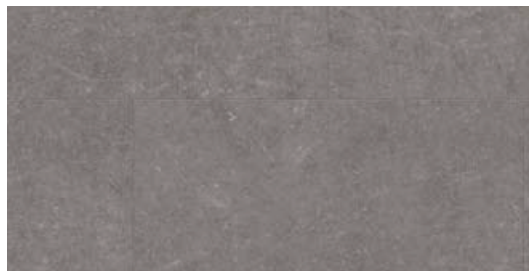

0618 Carmel 30.5 x 61 cm



0583 Deep Oak 18.4 x 121.9 cm



0374 Parker Station 30.5 x 61 cm



DESIGN SHADE VARIATION:  Light  Medium  High

LUXURY VINYL TILE

CREATION 55

▶ EXCLUSIVE EMBOSSES FOR ENHANCED DESIGNS

HAMMERED

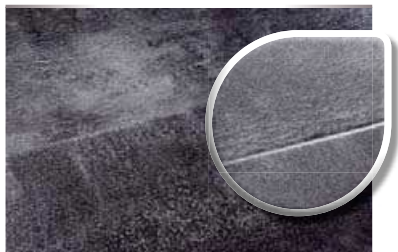

STONE



RUSTIC WOOD

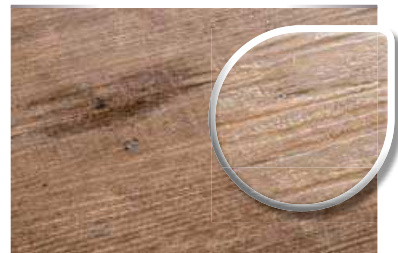

SLATE



SAND



AUTHENTIC



PERFORATED



BRUSHED



SAW EFFECT



NATURAL

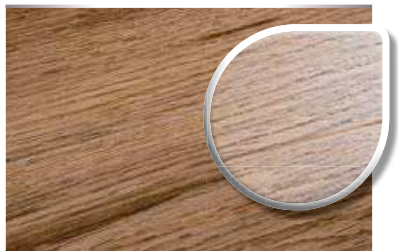

LIGHT



CREATION 55



CREATION 55 CREATION 55 CREATION 55



Code Slip Resistance wet (DIN 51130) / Embosses

| Code | Slip Resistance wet (DIN 51130) / Embosses | Slip Resistance wet (DIN 51130) / Embosses | Slip Resistance wet (DIN 51130) / Embosses |
|----------------------|--------------------------------------------|--------------------------------------------|--------------------------------------------|
| ALISIER | 0578 | R9 - SAW EFFECT | R9 - HAMMERED LIGHT |
| AMADOR | 0447 | R9 - SAW EFFECT | R9 - HAMMERED LIGHT |
| AMARANTE | 0579 | R10 - RUSTIC WOOD | R10 - BRUSHED |
| ANATHEMA | 0500 | R9 - SAND | R10 - HAMMERED |
| CARMEL | 0618 | R10 - HAMMERED | R9 - HAMMERED LIGHT |
| DEEP OAK | 0583 | R10 - RUSTIC WOOD | R10 - BRUSHED |
| PARKER STATION | 0374 | R10 - HAMMERED | R10 - HAMMERED |
| RANCH | 0456 | R10 - BRUSHED | R10 - BRUSHED |
| RIVERSIDE | 0436 | R10 - HAMMERED | R10 - HAMMERED |
| WHITE LIME | 0584 | R9 - SAW EFFECT | R9 - HAMMERED LIGHT |
| ARENA | 0060 | R9 - SAW EFFECT | R9 - HAMMERED LIGHT |
| ASPEN | 0458 | R10 - BRUSHED | R10 - BRUSHED |
| BALLERINA | 0347 | R9 - NATURAL | R9 - NATURAL |
| BROWNIE | 0459 | R9 - NATURAL | R9 - NATURAL |
| BUFFALO | 0457 | R10 - BRUSHED | R10 - BRUSHED |
| CALDWELL | 0488 | R9 - NATURAL | R9 - NATURAL |
| CAMBRIDGE | 0465 | R9 - NATURAL | R9 - NATURAL |
| DEER | 0582 | R9 - SAW EFFECT | R9 - HAMMERED LIGHT |
| EASTERN OAK | 0462 | R9 - NATURAL | R9 - NATURAL |
| HONEY OAK | 0441 | R9 - NATURAL | R9 - NATURAL |
| LAVA GREY | 0967 | R9 - STONE | R9 - HAMMERED LIGHT |
| LAVA LIGHT | 0966 | R9 - STONE | R9 - HAMMERED LIGHT |
| LONG BOARD | 0455 | R10 - BRUSHED | R10 - BRUSHED |
| LORENZO | 0446 | R9 - SAW EFFECT | R9 - HAMMERED LIGHT |
| MALUA BAY | 0448 | R10 - BRUSHED | R10 - BRUSHED |
| MANSFIELD DARK | 0042 | R10 - BRUSHED | R10 - BRUSHED |
| MICHIGAN | 0461 | R9 - SAW EFFECT | R9 - NATURAL |
| MILINGTON OAK | 0442 | R9 - NATURAL | R9 - NATURAL |
| MORENA | 0489 | R10 - BRUSHED | R10 - BRUSHED |
| NORVEGIAN SLATE | 0438 | R10 - SLATE | R10 - HAMMERED |
| OXFORD | 0061 | R10 - BRUSHED | R10 - BRUSHED |
| PASADENA | 0386 | R10 - BRUSHED | R10 - BRUSHED |
| PICADILLY | 0464 | R9 - NATURAL | R9 - NATURAL |
| PRESTON | 0620 | R10 - HAMMERED | R9 - HAMMERED LIGHT |
| QUARTET | 0503 | R9 - NATURAL | R9 - NATURAL |
| ROXBURY | 0964 | R10 - HAMMERED | R10 - HAMMERED |
| RUSTIC OAK | 0445 | R9 - LIGHT | R9 - NATURAL |
| SILVER CITY | 0373 | R10 - HAMMERED | R10 - HAMMERED |
| SOLERO CREME | 0071 | R9 - NATURAL | R9 - NATURAL |
| TWIST | 0504 | R9 - NATURAL | R9 - NATURAL |
| ARYA | 0581 | R10 - RUSTIC WOOD | |
| BOSTONIAN OAK GOLD | 0814 | R9 - NATURAL | |
| BOSTONIAN OAK HONEY | 0815 | R9 - NATURAL | |
| BRITANY OAK | 0425 | R10 - AUTHENTIC | |
| CHEVRON BUCKWHEAT | 0811 | R9 - NATURAL | |
| CHEVRON HURRICANE | 0809 | R9 - NATURAL | |
| CHEVRON MOKA | 0810 | R9 - NATURAL | |
| ELEGANT OAK | 0070 | R9 - NATURAL | |
| ERAMOSIA CREME | 0063 | R9 - NATURAL | |
| ERAMOSIA GOLD | 0062 | R9 - NATURAL | |
| FACTORY | 0487 | R9 - SAND | |
| FUDGE | 0463 | R9 - NATURAL | |
| GRAVITY DARK | 0064 | R10 - BRUSHED | |
| GRAVITY WOOD | 0065 | R10 - BRUSHED | |
| MAHE | 0066 | R9 - NATURAL | |
| MAHE GREY | 0067 | R9 - NATURAL | |
| MANSFIELD LIGHT | 0068 | R10 - BRUSHED | |
| MANSFIELD NATURAL | 0069 | R10 - BRUSHED | |
| MOMA | 0045 | R10 - HAMMERED | |
| NATURAL CHERRY | 0449 | R9 - NATURAL | |
| NORTH WOOD MACCHIATO | 0816 | R10 - BRUSHED | |
| NORTH WOOD MOKACCINO | 0817 | R10 - BRUSHED | |
| ROCKAWAY | 0048 | R10 - HAMMERED | |
| ROYAL OAK COFFEE | 0740 | R9 - GENUINE | |
| ROYAL OAK BLOND | 0812 | R9 - GENUINE | |
| RUST METAL | 0094 | R11 - PERFORATED | |
| RUST CORTEN | 0095 | R11 - PERFORATED | |
| SPICY BROWN | 0073 | R9 - NATURAL | |
| SPICY GREY BLUE | 0072 | R9 - NATURAL | |
| STACCATO | 0476 | R11 - PERFORATED | |
| SWEET CLOUD | 0437 | R9 - STONE | |
| SWISS OAK CASHMERE | 0795 | R9 - NATURAL | |
| SWISS OAK GOLDEN | 0796 | R9 - NATURAL | |
| VINTAGE OAK | 0426 | R10 - AUTHENTIC | |

LUXURY VINYL TILE

CREATION 55

CREATION 55

CREATION 55
CLIC SYSTEM

CREATION 55
X'PRESS

SKIRTING
100% Matching

Code



| Code | CREATION 55 | CREATION 55 CLIC SYSTEM | CREATION 55 X'PRESS | SKIRTING 100% Matching |
|----------------------|-------------|-------------------------|---------------------|------------------------|
| ALISIER | 0578 | • | • | - |
| AMADOR | 0447 | • | • | 0447 |
| AMARANTE | 0579 | • | • | - |
| CARMEL | 0618 | • | • | - |
| DEEP OAK | 0583 | • | • | - |
| PARKER STATION | 0374 | • | • | - |
| RANCH | 0456 | • | • | 0357 |
| RIVERSIDE | 0436 | • | • | - |
| WHITE LIME | 0584 | • | • | 0582 |
| ANATHEMA | 0500 | • | • | 0414 |
| ARENA | 0060 | • | • | 0356 |
| ASPEN | 0458 | • | • | 0458 |
| BALLERINA | 0347 | • | • | 0347 |
| BROWNIE | 0459 | • | • | 0265 |
| BUFFALO | 0457 | • | • | 0359 |
| CALDWELL | 0488 | • | • | 0488 |
| CAMBRIDGE | 0465 | • | • | 0272 |
| DEER | 0582 | • | • | 0584 |
| EASTERN OAK | 0462 | • | • | 0258 |
| HONEY OAK | 0441 | • | • | 0441 |
| LAVA GREY | 0967 | • | • | - |
| LAVA LIGHT | 0966 | • | • | - |
| LONG BOARD | 0455 | • | • | 0358 |
| LORENZO | 0446 | • | • | 0446 |
| MALUA BAY | 0448 | • | • | 0448 |
| MANSFIELD DARK | 0042 | • | • | - |
| MICHIGAN | 0461 | • | • | 0461 |
| MILINGTON OAK | 0442 | • | • | 0442 |
| MORENA | 0489 | • | • | 0489 |
| NORVEGIAN SLATE | 0438 | • | • | - |
| OXFORD | 0061 | • | • | - |
| PASADENA | 0386 | • | • | 0386 |
| PICADILLY | 0464 | • | • | 0337 |
| PRESTON | 0620 | • | • | - |
| QUARTET | 0503 | • | • | 0503 |
| ROXBURY | 0964 | • | • | - |
| RUSTIC OAK | 0445 | • | • | 0445 |
| SILVER CITY | 0373 | • | • | - |
| SOLERO CREME | 0071 | • | • | - |
| TWIST | 0504 | • | • | 0504 |
| ARYA | 0581 | • | • | - |
| BOSTONIAN OAK GOLD | 0814 | • | • | 0814 |
| BOSTONIAN OAK HONEY | 0815 | • | • | 0815 |
| BRITANY OAK | 0425 | • | • | - |
| CHEVRON BUCKWHEAT | 0811 | • | • | 0811 |
| CHEVRON HURRICANE | 0809 | • | • | 0809 |
| CHEVRON MOKA | 0810 | • | • | 0810 |
| ELEGANT OAK | 0070 | • | • | 0260 |
| ERAMOSA CREME | 0063 | • | • | 0063 |
| ERAMOSA GOLD | 0062 | • | • | 0062 |
| FACTORY | 0487 | • | • | - |
| FUDGE | 0463 | • | • | 0262 |
| GRAVITY DARK | 0064 | • | • | - |
| GRAVITY WOOD | 0065 | • | • | - |
| MAHE | 0066 | • | • | - |
| MAHE GREY | 0067 | • | • | - |
| MANSFIELD LIGHT | 0068 | • | • | - |
| MANSFIELD NATURAL | 0069 | • | • | - |
| MOMA | 0045 | • | • | - |
| NATURAL CHERRY | 0449 | • | • | - |
| NORTH WOOD MACCHIATO | 0816 | • | • | 0816 |
| NORTH WOOD MOKACCINO | 0817 | • | • | 0817 |
| ROCKAWAY | 0048 | • | • | - |
| ROYAL OAK COFFEE | 0740 | • | • | 0740 |
| ROYAL OAK BLOND | 0812 | • | • | 0812 |
| RUST METAL | 0094 | • | • | 0094 |
| RUST CORTEN | 0095 | • | • | 0095 |
| SPICY BROWN | 0073 | • | • | - |
| SPICY GREY BLUE | 0072 | • | • | - |
| STACCATO | 0476 | • | • | 0476 |
| SWEET CLOUD | 0437 | • | • | - |
| SWISS OAK CASHMERE | 0795 | • | • | 0795 |
| SWISS OAK GOLDEN | 0796 | • | • | 0796 |
| VINTAGE OAK | 0426 | • | • | - |

• Available

PACKAGING

| Product size (cm) | m ² / box | m ² / palette |
|--------------------------------|----------------------|--------------------------|
| CREATION 55 | | |
| 15.2 x 91.4 ⁽¹⁾ | 3.34 | 257.18 |
| 15.2 x 91.4 | 3.34 | 220.44 |
| 18.4 x 121.9 | 3.37 | 252.75 |
| 23 x 150 | 2.80 | 198.72 |
| Mix: 15.2/7.6/22.8 x 91.4 | 3.34 | 213.76 |
| 18.4 x 137.1 | 3.03 | 242.40 |
| 45.7 x 91.4 | 3.34 | 213.76 |
| 61 x 61 | 3.34 | 160.32 |
| 30.5 x 61 | 3.34 | 140.28 |
| CREATION 55 CLIC SYSTEM | | |
| 17.6 x 100 | 1.76 | 98.56 |
| 36 x 69.6 | 1.75 | 94.70 |
| 20.4 x 123.9 | 1.77 | 113.20 |
| CREATION 55 X'PRESS | | |
| 18.4 x 121.9 | 1.79 | 144.00 |
| 30.5 x 61 | 1.86 | 83.70 |

[1] Ranch/Cambridge/Brownie/Longboard

CREATION 55

▶ DECOR SKIRTING

To be installed with clip (5935) or mastic adhesive.

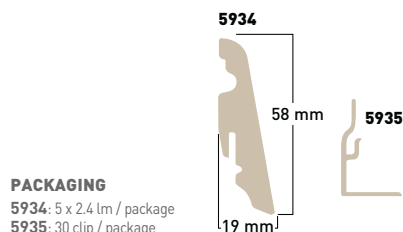

PACKAGING
5934: 5 x 2.4 lm / package
5935: 30 clip / package



▶ CREATION 55 WOOD: 28 matching decors



▶ CREATION 55 MINERAL : 10 decors

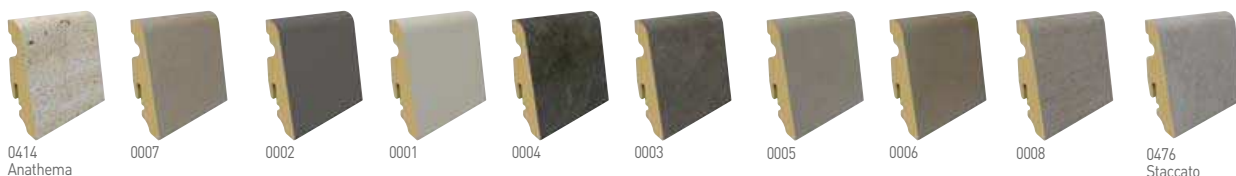

▶ ALUMINIUM PROFILES

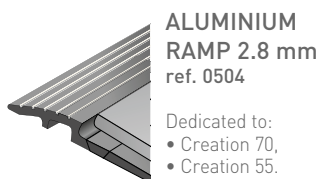

For further details see page 283

LUXURY VINYL TILE

CREATION 30

▶ CREATION 30

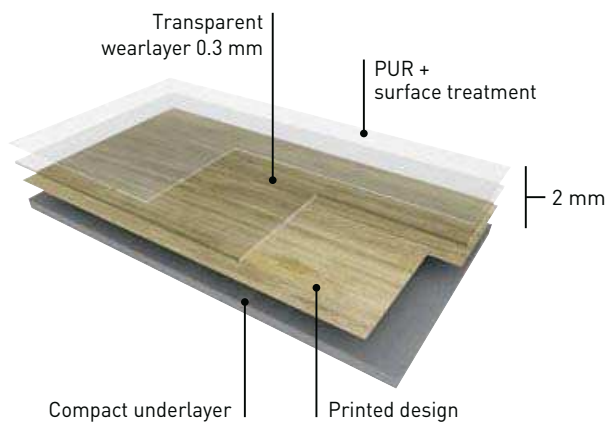

CREATION 30 are synthetic, decorative, flexible, antistatic, abrasion group T floorcoverings in tile and plank form, with micro-bevelled edges.

They consist of a 0.3 mm thick transparent wear layer, a design film and a compact underlayer. They are compressed and grained at high pressure.

Their overall thickness is 2 mm. They are treated with **PUR+** surface treatment providing excellent cleaning characteristics and improved resistance to scratching. PUR+ treatment significantly delays the build-up of wax.



CREATION 30

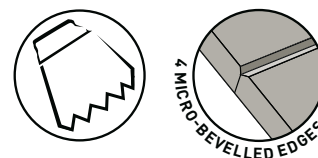

- ▶ Micro-bevelled edges: unique and realistic design.
- ▶ Large palette of designs and formats.
- ▶ Durability.
- ▶ PUR+ surface treatment: ease of maintenance.

| | | | CREATION 30 |
|----------------------------------|--------------------------|---------------------|--------------------------------------------------------------------------------------------------------------------------------------------|
| | | | DESIGN |
| DESCRIPTION | | | |
| Total thickness | EN ISO 24346 (EN 428) | mm | 2.00 |
| Thickness of wearlayer | EN ISO 24340 (EN 429) | mm | 0.30 |
| Weight | EN ISO 23997 (EN 430) | g/sq.m | 3460 |
| Size | EN ISO 24342 (EN 427) | mm | Planks - 184x1371 / 184x1219 / 152x914 / 114x610 Tiles - 457x914 / 610x610 / 305x610 Creation Mix: 152x914 / 228x914 / 76x914 |
| CLASSIFICATION | | | |
| Norm / Product specification | - | - | EN ISO 10582 (EN 649) |
| European classification | EN ISO 10874 (EN 685) | class | 23 - 31 |
| Fire rating | EN 13501-1 | class | B _{fl} -s1 |
| Static electrical propensity | EN 1815 | kV | < 2 |
| Slip resistance wet | DIN 51 130 | class | R9-R10-R11 ^[1] |
| PERFORMANCES | | | |
| Wear resistance | EN 660.2 | mm ³ | ≤ 2.0 |
| Wear group | NF 189 | group | T |
| Type Binder content | ISO 10582 | type | I |
| Room impact | NF S 31074 | dB | 77 |
| Impact sound insulation | EN ISO 717-2 | dB | 4 |
| Dimensional stability | EN ISO 23999 (EN 434) | % | ≤ 0.15 |
| Residual indentation | EN ISO 24343-1 (EN 433) | mm | ≤ 0.10 |
| Castor chair test (type W) | ISO 4918 (EN 425) | - | OK |
| Thermal conductivity | EN ISO 10456 (EN 12 524) | W/(m.k) | 0.25 |
| Colour fastness | EN 20 105 - B02 | degree | ≥ 6 |
| Surface treatment | - | - | PUR+ |
| Chemical products resistance | EN ISO 26987 (EN 423) | - | OK |
| ENVIRONMENT / INDOOR AIR QUALITY | | | |
| TVOC after 28 days | ISO 16000-6 | µg / m ³ | <100 |
| CE MARKING | | | |
| CE | EN 14041 | | |
| | | | |

[1] Slip resistance wet: details on website gerflor.com

LUXURY VINYL TILE

CREATION 30



0441 Honey Oak

15.2x91.4 cm



0589 Break Dance

18.4 x 121.9 cm



0445 Rustic Oak

15.2x91.4 cm



0502 Rumba

15.2x91.4 cm

CREATION 30

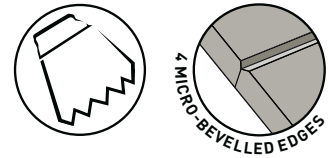

 Compact
  Compact
 | PUR+
  100% recyclable



0465 Cambridge 15.2x91.4 cm



0488 Folk 15.2x91.4 cm



0588 Bossa Nova 18.4 x 121.9 cm



0262 Tempo 15.2x91.4 cm



0347 Ballerina 15.2x91.4 cm



0499 Pavane 15.2x91.4 cm



0503 Quartet 15.2x91.4 cm



0349 Mazurka 15.2x91.4 cm



0498 Tango 15.2x91.4 cm



0265 Morris 15.2x91.4 cm



DESIGN SHADE VARIATION:  Light  Medium  High

LUXURY VINYL TILE

CREATION 30

Compact Compact PUR+ 100% recyclable

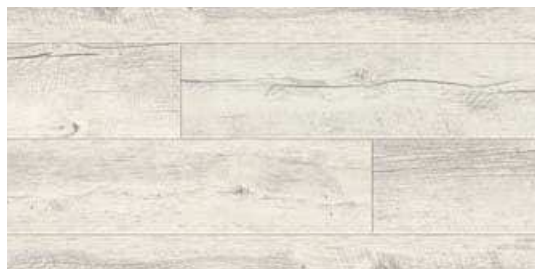

0489 Calypso

15.2x91.4 cm



0743 North Wood

18.4 x 121.9 cm



0060 Arena

18.4 x 121.9 cm



0593 Salsa

18.4 x 121.9 cm



0591 Milonga

18.4 x 121.9 cm



0737 Alamo Ash

18.4 x 121.9 cm



0061 Oxford

18.4 x 121.9 cm



0447 Amador

15.2x91.4 cm



0592 Paso Doble

18.4 x 121.9 cm



0587 Cumbia

18.4 x 121.9 cm



CREATION 30

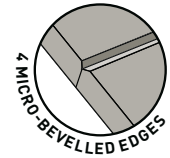
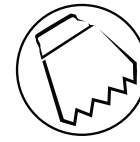

PUR+

100% recyclable



0590 Sirtaki

18.4 x 121.9 cm



0586 Tamoure

18.4 x 121.9 cm



0491 Madison

15.2x91.4 cm



0504 Twist

15.2x91.4 cm



0585 Bebop

18.4 x 121.9 cm



DESIGN SHADE VARIATION:



Light



Medium



High

Luxury Vinyl Tile

LUXURY VINYL TILE

CREATION 30



0490 Boogie 15.2x91.4 cm
18.4 x 121.9 cm



0492 Bamba 15.2x91.4 cm



0457 Buffalo 15.2x91.4 cm



0738 Alamo Sand 18.4 x 121.9 cm



CREATION 30

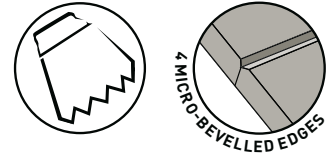

 Compact
  Compact
 PUR+
 100% recyclable



0739 Royal Oak Gold 18.4 x 121.9 cm



0742 Timber Camel 11.4 x 61 cm / 18.4 x 121.9 cm



0501 Charleston 15.2x91.4 cm



0741 Timber Rust 11.4 x 61 cm / 18.4 x 121.9 cm



0386 Pasadena Creation 30 Mix 15.2x91.4 cm / 7.6x91.4 cm / 22.8x91.4 cm



0740 Royal Oak Coffee 18.4 x 121.9 cm



0749 Bostonian 18.4 x 137.1 cm



0493 Flamenco 15.2x91.4 cm



DESIGN SHADE VARIATION:  Light  Medium  High

Luxury Vinyl Tile

LUXURY VINYL TILE

CREATION 30



0414 Soprano

30.5 x 61 cm



0751 Durango Taupe

61x61 cm



0750 Durango Moka

61x61 cm

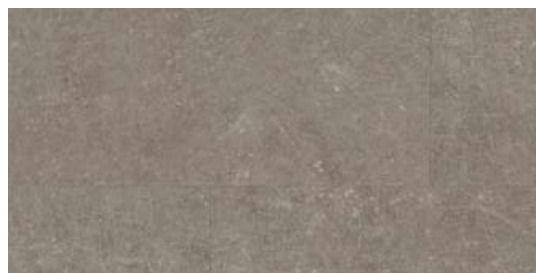

0618 Carmel

30.5 x 61 cm



0373 Silver City

61x61 cm

CREATION 30

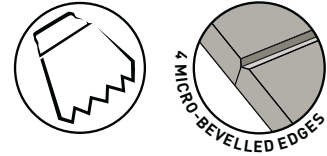

 Compact
  Compact
 | PUR+
  100% recyclable



0476 Staccato 61x61 cm



0744 Carrare 30.5 x 61 cm
18.4 x 121.9 cm



0436 Riverside 61x61 cm



0475 Bolero 30.5 x 61 cm



0505 Andante 61x61 cm



0748 Back Street 30.5 x 61 cm



0374 Parker Station 61x61 cm



0747 Pashmina Cloud 45.7 x 91.4 cm



0438 Norwegian Slate 30.5 x 61 cm



0746 Pashmina Storm 45.7 x 91.4 cm



DESIGN SHADE VARIATION:  Light  Medium  High

Luxury Vinyl Tile

LUXURY VINYL TILE

CREATION 30 LOCK

▶ CREATION 30 LOCK.....

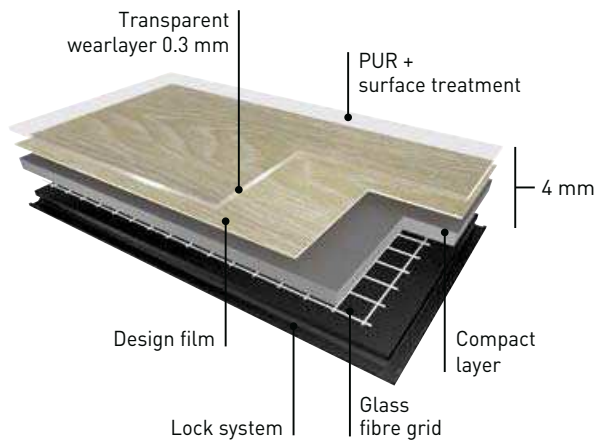

CREATION 30 LOCK is a synthetic, decorative, flexible, antistatic, abrasion group T floorcovering available in planks and tiles with micro-bevelled edges. **CREATION 30 LOCK** is a 4mm thick product, it consists of a transparent wearlayer 0.3mm thick, a design film and two compact underlayers reinforced with a fibre grid. The product is compressed and grained at high pressure.

CREATION 30 LOCK is treated with polyurethane treatment **PUR+** that provides good cleaning properties and improved resistance to scratches and chemicals.

CREATION 30 LOCK is made with 73% of mineral and 12% inexhaustible materials. It is made with 100% control recycled materials. It is 100% compliant with REACH. The product emission rate of organic compounds is $< 100\mu\text{g}/\text{m}^3$ (TVOC < 28 days - ISO 16000-6). It is 100% recyclable.

CREATION 30 LOCK is a loose-lay product that can be installed without adhesive thanks to the interlocking system.

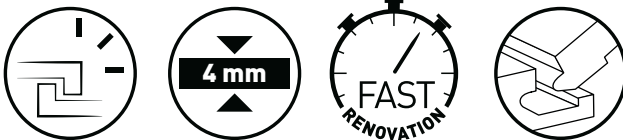

CREATION 30 LOCK

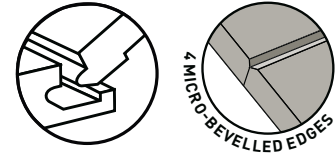

EASY INSTALLATION / EASY RENOVATION

- ▶ Loose lay interlocking system
 - Installation with no adhesive
 - Quick installation
 - Few tools: cutter and mallet
- ▶ Minimum subfloor preparation: CREATION 30 LOCK is compatible with seamless tile, concrete, PVC compact, wood floor (if subfloor rigid & stable)*

*[In compliance with Gerflor's installation guidelines]

| | | | CREATION 30 LOCK |
|----------------------------------|--------------------------|---------------------|---------------------------|
| DESCRIPTION | | | |
| Total thickness | EN ISO 24346 (EN 428) | mm | 4.00 |
| Thickness of wearlayer | EN ISO 24340 (EN 429) | mm | 0.30 |
| Weight | EN ISO 23997 (EN 430) | g/sq.m | 7760 |
| Plank size | EN ISO 24342 (EN 427) | mm | 178 x 1245 |
| Tile size | EN ISO 24342 (EN 427) | mm | 303 x 607 |
| CLASSIFICATION | | | |
| Norm / Product specification | - | - | EN ISO 10582 (EN 649) |
| European classification | EN ISO 10874 (EN 685) | class | 23 - 31 |
| Fire rating | EN 13501-1 | class | B _{fl} -s1 |
| Static electrical propensity | EN 1815 | kV | < 2 |
| Slip resistance wet | DIN 51 130 | class | R9-R10-R11 ^[1] |
| PERFORMANCES | | | |
| Wear resistance | EN 660.2 | mm ³ | ≤ 2.0 |
| Wear group | NF 189 | group | T |
| Type Binder content | ISO 10582 | type | I |
| Room impact | NF S 31074 | dB | 76 |
| Impact sound insulation | EN ISO 717-2 | dB | 4 |
| Dimensional stability | EN ISO 23999 (EN 434) | % | ≤ 0.15 |
| Residual indentation | EN ISO 24343-1 (EN 433) | mm | ≤ 0.10 |
| Castor chair test (type W) | ISO 4918 (EN 425) | - | OK |
| Thermal conductivity | EN ISO 10456 (EN 12 524) | W/(m.k) | 0.25 |
| Colour fastness | EN 20 105 - B02 | degree | ≥ 6 |
| Surface treatment | - | - | PUR+ |
| Chemical products resistance | EN ISO 26987 (EN 423) | - | OK |
| ENVIRONMENT / INDOOR AIR QUALITY | | | |
| TVOC after 28 days | ISO 16000-6 | µg / m ³ | <100 |
| CE MARKING | | | |
| CE | EN 14041 | | |
| | | | |

[1] Slip resistance wet: details on website gerflor.com

LUXURY VINYL TILE

CREATION 30 LOCK

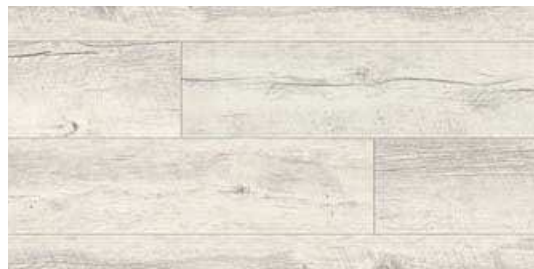

0489 Calypso

17.8x124.5 cm



0586 Tamoure

17.8x124.5 cm



0491 Madison

17.8x124.5 cm



0504 Twist

17.8x124.5 cm

CREATION 30 LOCK

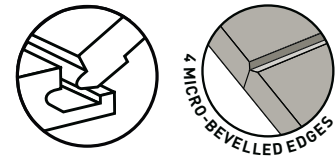

-  Compact
-  Compact
- PUR+**
-  100% recyclable



0441 Honey Oak 17.8x124.5 cm



0585 Bebop 17.8x124.5 cm



0347 Ballerina 17.8x124.5 cm



0445 Rustic Oak 17.8x124.5 cm



0503 Quartet 17.8x124.5 cm



0589 Break Dance 17.8x124.5 cm



0265 Morris 17.8x124.5 cm



0490 Boogie 17.8x124.5 cm



DESIGN SHADE VARIATION:  Light  Medium  High

LUXURY VINYL TILE

CREATION 30 LOCK



0060 Arena

17.8x124.5 cm



0414 Soprano

30.3x60.7 cm



0593 Salsa

17.8x124.5 cm



0475 Bolero

30.3x60.7 cm



0447 Amador

17.8x124.5 cm

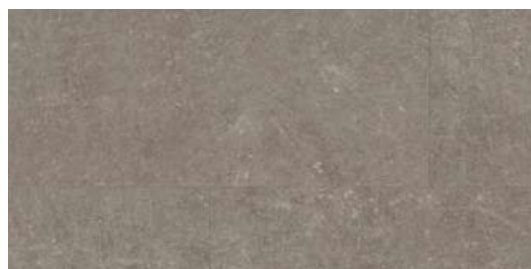

0618 Carmel

30.3x60.7 cm



0061 Oxford

17.8x124.5 cm

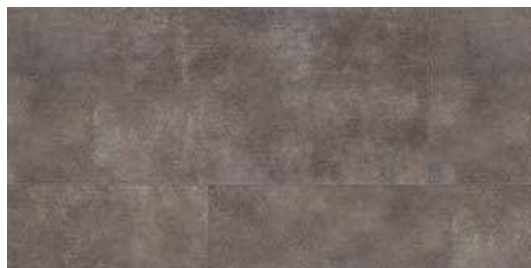

0373 Silver City

30.3x60.7 cm



DESIGN SHADE VARIATION:



Light



Medium



High

CREATION 30 LOCK

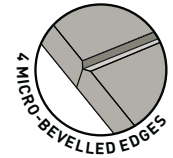
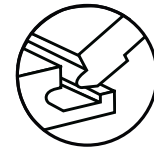

PUR+

100% recyclable



0476 Staccato

30.3x60.7 cm

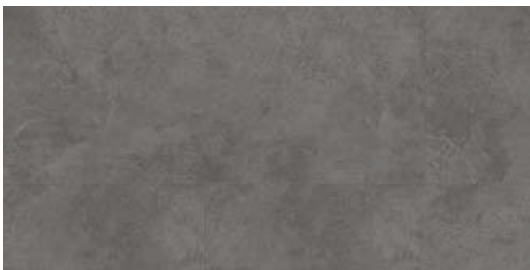

0436 Riverside

30.3x60.7 cm



0505 Andante

30.3x60.7 cm



0374 Parker Station

30.3x60.7 cm



Luxury Vinyl Tile

LUXURY VINYL TILE

CREATION 30 X'PRESS

▶ CREATION 30 X'PRESS

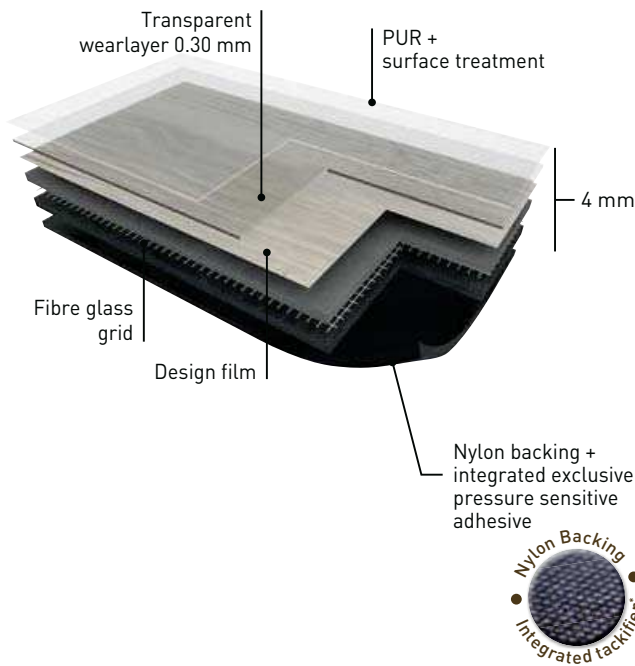

CREATION 30 X'PRESS is a synthetic, decorative, flexible, abrasion group T product available in tiles and planks with bevelled edges. It comprises a 0,30mm thick transparent wearlayer.

It is a 4mm compact product, compressed and grained at high pressure, made with a design film, two compact underlayers reinforced with a fibre grid. The product includes "Pressure Sensitive Adhesive" (PSA) on the nylon backing. Subfloor is clean after removal.

CREATION 30 X'PRESS is treated with a **PUR+** treatment for easy maintenance properties.

CREATION 30 X'PRESS is made with 73% of mineral and 12% inexhaustible materials. It is made with 100% recycled materials. It is 100% compliant with REACH. The product emission rate of organic compounds is $< 100\mu\text{g}/\text{m}^3$ (TVOC < 28 days - ISO 16000-6). It is 100% recyclable.

*Exclusive "Pressure Sensitive Adhesive" (PSA) on clean subfloor



CREATION 30 X'PRESS

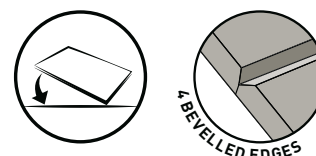

PUR+



► Ready to use:

- Looselay = Pressure Sensitive Adhesive (PSA) included on the backing of the product
- Direct installation on existing subfloor (In compliance with Gerflor's installation guidelines)
- Clean and quiet for easy installation in busy areas

► Removable:

- No tools needed to remove floor
- Easy to replace a single plank/tile
- Subfloor is clean after removal*

► Easy:

- One tool required: a sharp blade
- Just press to install the product

* For more information please refer to Gerflor's guidelines.

CREATION 30 X'PRESS

| DESCRIPTION | | | |
|-----------------------------------------|--------------------------|---------------------|---------------------------|
| Total thickness | EN ISO 24346 [EN 428] | mm | 4.00 |
| Thickness of wearlayer | EN ISO 24340 [EN 429] | mm | 0.30 |
| Weight | EN ISO 23997 [EN 430] | g/sq.m | 7600 |
| Plank size | EN ISO 24342 [EN 427] | mm | 184 x 1219 |
| Tile size | EN ISO 24342 [EN 427] | mm | 305 x 610 |
| CLASSIFICATION | | | |
| Norm / Product specification | - | - | EN ISO 10582 [EN 649] |
| European classification | EN ISO 10874 [EN 685] | class | 23 - 31 |
| Fire rating | EN 13501-1 | class | Bfl-s1 |
| Static electrical propensity | EN 1815 | kV | < 2 |
| Slip resistance wet: ramp test with oil | DIN 51 130 | class | R9-R10-R11 ^[1] |
| PERFORMANCES | | | |
| Wear resistance | EN 660.2 | mm ³ | ≤ 2.0 |
| Wear group | NF 189 | group | T |
| Type Binder content | ISO 10582 | type | I |
| Room impact | NF S 31074 | dB | 74 |
| Impact sound insulation | EN ISO 717-2 | dB | 5 |
| Dimensional stability | EN ISO 23999 [EN 434] | % | ≤ 0.15 |
| Residual indentation | EN ISO 24343-1 [EN 433] | mm | ≤ 0.10 |
| Castor chair test (type W) | ISO 4918 [EN 425] | - | OK |
| Thermal conductivity | EN ISO 10456 [EN 12 524] | W/(m.k) | 0.25 |
| Colour fastness | EN 20 105 - B02 | degree | ≥ 6 |
| Surface treatment | - | - | PUR+ |
| Chemical products resistance | EN ISO 26987 [EN 423] | - | OK |
| ENVIRONMENT / INDOOR AIR QUALITY | | | |
| TVOC after 28 days | ISO 16000-6 | µg / m ³ | <100 |
| CE MARKING | | | |
| | EN 14041 | | |

[1] Slip resistance wet: details on website gerflor.com

LUXURY VINYL TILE

CREATION 30 X'PRESS

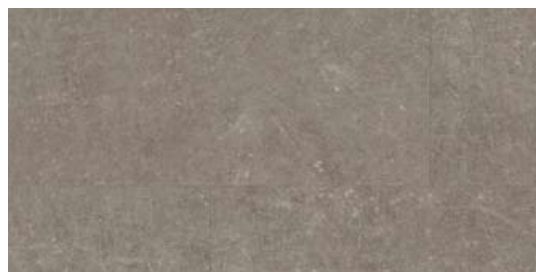

0618 Carmel

30.5 x 61 cm



0476 Staccato

30.5 x 61 cm

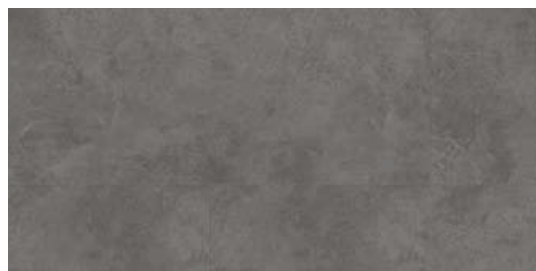

0436 Riverside

30.5 x 61 cm



0374 Parker Station

30.5 x 61 cm



CREATION 30 X'PRESS

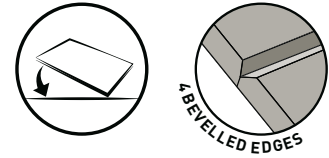

 Compact
  Compact
 PUR+
 100% recyclable



0504 Twist 18.4x121.9 cm 



0586 Tamoure 18.4x121.9 cm 



0585 Bebop 18.4x121.9 cm 



0593 Salsa 18.4x121.9 cm 



0347 Ballerina 18.4x121.9 cm 



0589 Break Dance 18.4x121.9 cm 



0503 Quartet 18.4x121.9 cm 



0490 Boogie 18.4x121.9 cm 



0265 Morris 18.4x121.9 cm 



0447 Amador 18.4 x 121.9 cm 

DESIGN SHADE VARIATION:  Light  Medium  High

LUXURY VINYL TILE

CREATION 30

▶ EXCLUSIVE EMBOSSES FOR ENHANCED DESIGNS

HAMMERED

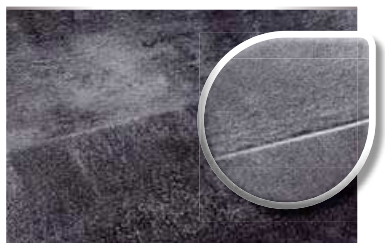

BRUSHED



STAMPED

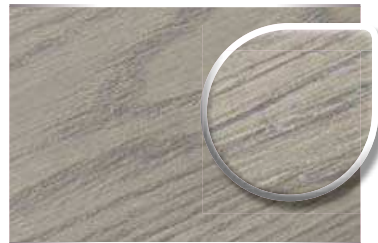

SLATE



LIGHT



SAW EFFECT



PERFORATED



NATURAL

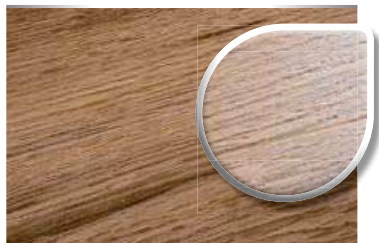

GENUINE



STONE



RUSTIC WOOD

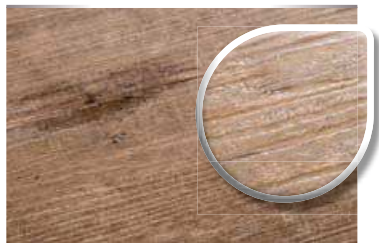

CREATION 30



CREATION 30 CREATION 30 CREATION 30







Code Slip Resistance wet (DIN 51130) / Embosses

| Code | Slip Resistance wet (DIN 51130) / Embosses | Slip Resistance wet (DIN 51130) / Embosses | Slip Resistance wet (DIN 51130) / Embosses |
|------------------|--------------------------------------------|--------------------------------------------|--------------------------------------------|
| AMADOR | 0447 | R9 - SAW EFFECT | R9 - SAW EFFECT |
| BALLERINA | 0347 | R9 - NATURAL | R9 - NATURAL |
| BEBOP | 0585 | R10 - BRUSHED | R10 - BRUSHED |
| BOOGIE | 0490 | R10 - BRUSHED | R10 - BRUSHED |
| BREAK DANCE | 0589 | R10 - RUSTIC WOOD | R10 - RUSTIC WOOD |
| CARMEL | 0618 | R10 - HAMMERED | R10 - HAMMERED |
| MORRIS | 0265 | R9 - NATURAL | R9 - NATURAL |
| PARKER STATION | 0374 | R10 - HAMMERED | R10 - HAMMERED |
| QUARTET | 0503 | R9 - NATURAL | R9 - NATURAL |
| RIVERSIDE | 0436 | R10 - HAMMERED | R10 - HAMMERED |
| SALSA | 0593 | R9 - SAW EFFECT | R9 - SAW EFFECT |
| STACCATO | 0476 | R11 - PERFORATED | R11 - PERFORATED |
| TAMOURE | 0586 | R10 - BRUSHED | R10 - BRUSHED |
| TWIST | 0504 | R9 - NATURAL | R9 - NATURAL |
| ANDANTE | 0505 | R9 - STONE | R9 - STONE |
| ARENA | 0060 | R9 - SAW EFFECT | R9 - SAW EFFECT |
| BOLERO | 0475 | R9 - STONE | R9 - STONE |
| CALYPSO | 0489 | R10 - BRUSHED | R10 - BRUSHED |
| HONEY OAK | 0441 | R9 - NATURAL | R9 - NATURAL |
| MADISON | 0491 | R10 - BRUSHED | R10 - BRUSHED |
| OXFORD | 0061 | R10 - BRUSHED | R10 - BRUSHED |
| RUSTIC OAK | 0445 | R9 - LIGHT | R9 - LIGHT |
| SILVER CITY | 0373 | R10 - HAMMERED | R10 - HAMMERED |
| SOPRANO | 0414 | R10 - HAMMERED | R10 - HAMMERED |
| ALAMO ASH | 0737 | R9 - STAMPED | |
| ALAMO SAND | 0738 | R9 - STAMPED | |
| BACK STREET | 0748 | R10 - HAMMERED | |
| BAMBA | 0492 | R10 - BRUSHED | |
| BOSSA NOVA | 0588 | R9 - SAW EFFECT | |
| BOSTONIAN | 0749 | R9 - NATURAL | |
| BUFFALO | 0457 | R10 - BRUSHED | |
| CAMBRIDGE | 0465 | R9 - NATURAL | |
| CARRARE | 0744 | R9 - STONE | |
| CHARLESTON | 0501 | R9 - SAW EFFECT | |
| CUMBIA | 0587 | R10 - RUSTIC WOOD | |
| DURANGO MOKA | 0750 | R10 - HAMMERED | |
| DURANGO TAUPE | 0751 | R10 - HAMMERED | |
| FLAMENCO | 0493 | R9 - SAW EFFECT | |
| FOLK | 0488 | R9 - NATURAL | |
| MAZURKA | 0349 | R9 - NATURAL | |
| MILONGA | 0591 | R9 - SAW EFFECT | |
| NORTH WOOD | 0743 | R10 - BRUSHED | |
| NORVEGIAN SLATE | 0438 | R10 - SLATE | |
| PASADENA | 0386 | R10 - BRUSHED | |
| PASHMINA CLOUD | 0747 | R9 - STONE | |
| PASHMINA STORM | 0746 | R9 - STONE | |
| PASO DOBLE | 0592 | R10 - RUSTIC WOOD | |
| PAVANE | 0499 | R9 - NATURAL | |
| ROYAL OAK COFFEE | 0740 | R9 - GENUINE | |
| ROYAL OAK GOLD | 0739 | R9 - GENUINE | |
| RUMBA | 0502 | R10 - BRUSHED | |
| SIRTAKI | 0590 | R10 - RUSTIC WOOD | |
| TANGO | 0498 | R9 - NATURAL | |
| TEMPO | 0262 | R9 - NATURAL | |
| TIMBER CAMEL | 0742 | R10 - BRUSHED | |
| TIMBER RUST | 0741 | R10 - BRUSHED | |

LUXURY VINYL TILE

CREATION 30

| | Code |  CREATION 30 (ARTLINE) |  CREATION 30 LOCK (ARTLINE LOCK) |  CREATION 30 X'PRESS |  SKIRTING 100% Matching |
|-----------------|------|-------------------------------------------------------------------------------------------------------------------|---------------------------------------------------------------------------------------------------------------------------------------|------------------------------------------------------------------------------------------------------------------------|--------------------------------------------------------------------------------------------------------------------|
| AMADOR | 0447 | • | • | • | 0447 |
| BALLERINA | 0347 | • | • | • | 0347 |
| BEBOP | 0585 | • | • | • | 0358 |
| BOOGIE | 0490 | • | • | • | 0357 |
| BREAK DANCE | 0589 | • | • | • | - |
| CARMEL | 0618 | • | • | • | - |
| MORRIS | 0265 | • | • | • | 0265 |
| PARKER STATION | 0374 | • | • | • | - |
| QUARTET | 0503 | • | • | • | 0503 |
| RIVERSIDE | 0436 | • | • | • | - |
| SALSA | 0593 | • | • | • | 0582 |
| STACCATO | 0476 | • | • | • | 0476 |
| TAMOURE | 0586 | • | • | • | 0448 |
| TWIST | 0504 | • | • | • | 0504 |
| ANDANTE | 0505 | • | • | - | - |
| ARENA | 0060 | • | • | - | 0356 |
| BOLERO | 0475 | • | • | - | - |
| CALYPSO | 0489 | • | • | - | 1489 |
| HONEY OAK | 0441 | • | • | - | 0441 |
| MADISON | 0491 | • | • | - | 0491 |
| OXFORD | 0061 | • | • | - | - |
| RUSTIC OAK | 0445 | • | • | - | 0445 |
| SILVER CITY | 0373 | • | • | - | - |
| SOPRANO | 0414 | • | • | - | 0414 |
| ALAMO ASH | 0737 | • | - | - | - |
| ALAMO SAND | 0738 | • | - | - | - |
| BACK STREET | 0748 | • | - | - | - |
| BAMBA | 0492 | • | - | - | 0492 |
| BOSSA NOVA | 0588 | • | - | - | - |
| BOSTONIAN | 0749 | • | - | - | - |
| BUFFALO | 0457 | • | - | - | 0359 |
| CAMBRIDGE | 0465 | • | - | - | 0272 |
| CARRARE | 0744 | • | - | - | - |
| CHARLESTON | 0501 | • | - | - | - |
| CUMBIA | 0587 | • | - | - | 0458 |
| DURANGO MOKA | 0750 | • | - | - | - |
| DURANGO TAUPE | 0751 | • | - | - | - |
| FLAMENCO | 0493 | • | - | - | - |
| FOLK | 0488 | • | - | - | - |
| MAZURKA | 0349 | • | - | - | 0442 |
| MILONGA | 0591 | • | - | - | 0584 |
| NORTH WOOD | 0743 | • | - | - | - |
| NORVEGIAN SLATE | 0438 | • | - | - | - |
| PASADENA | 0386 | • | - | - | 0386 |
| PASHMINA CLOUD | 0747 | • | - | - | - |
| PASHMINA STORM | 0746 | • | - | - | - |
| PASO DOBLE | 0592 | • | - | - | - |
| PAVANE | 0499 | • | - | - | - |
| ROYAL OAK COFFE | 0740 | • | - | - | 0740 |
| ROYAL OAK GOLD | 0739 | • | - | - | - |
| RUMBA | 0502 | • | - | - | 0360 |
| SIRTAKI | 0590 | • | - | - | - |
| TANGO | 0498 | • | - | - | - |
| TEMPO | 0262 | • | - | - | 0262 |
| TIMBER CAMEL | 0742 | • | - | - | - |
| TIMBER RUST | 0741 | • | - | - | - |

• : Available



PACKAGING

| Product size (cm) | m ² / box | m ² / palette |
|----------------------------------------|----------------------|--------------------------|
| CREATION 30 (ARTLINE) | | |
| 11.4 x 61 | 3.34 | 293.92 |
| 15.2 x 91.4 | 3.34 | 240.48 |
| 18.4 x 121.9 | 3.36 | 302.40 |
| 18.4 x 137.1 | 3.03 | 287.85 |
| 30.5 x 61 | 3.34 | 160.32 |
| 61 x 61 | 3.35 | 187.04 |
| 45.7 x 91.4 | 3.34 | 240.48 |
| 7.6 x 15.2 x 22.8 x 91.4 | 3.34 | 240.48 |
| CREATION 30 LOCK (ARTLINE LOCK) | | |
| 17.8 x 124.5 | 1.77 | 141.60 |
| 30.3 x 60.7 | 1.84 | 143.52 |
| CREATION 30 X'PRESS | | |
| 18.4 x 121.9 | 1.79 | 143.20 |
| 30.5 x 61 | 1.86 | 83.70 |

CREATION 30

▶ DECOR SKIRTING

To be installed with clip (5935) or mastic adhesive.

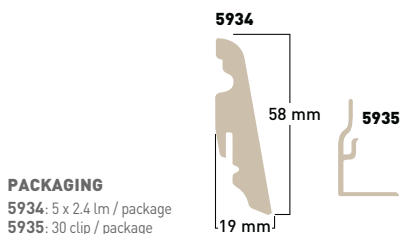

PACKAGING
 5934: 5 x 2.4 lm / package
 5935: 30 clip / package



▶ CREATION 30 WOOD : 24 matching decors



▶ CREATION 30 MINERAL : 13 decors

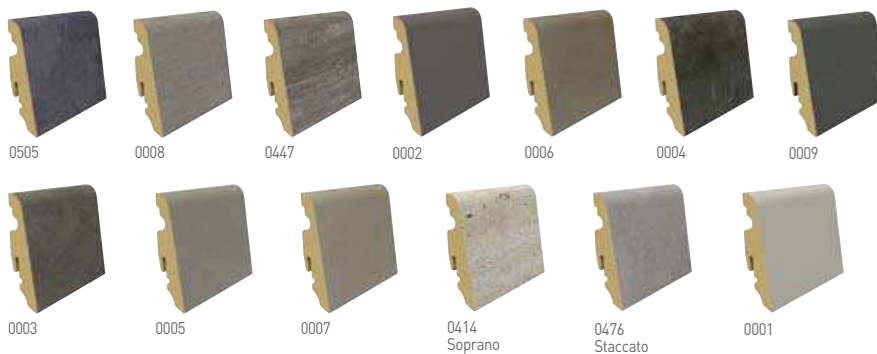



.....

FAST TRACK
LOOSELAY TILE

..... PAGES

192/207

.....



GTI **196-203**

- GTI MAX **NEW** 196-199
- GTI EL5 **NEW** 200-203

Attraction® **NEW** .. **204-207**

FAST TRACK LOOSELAY TILE

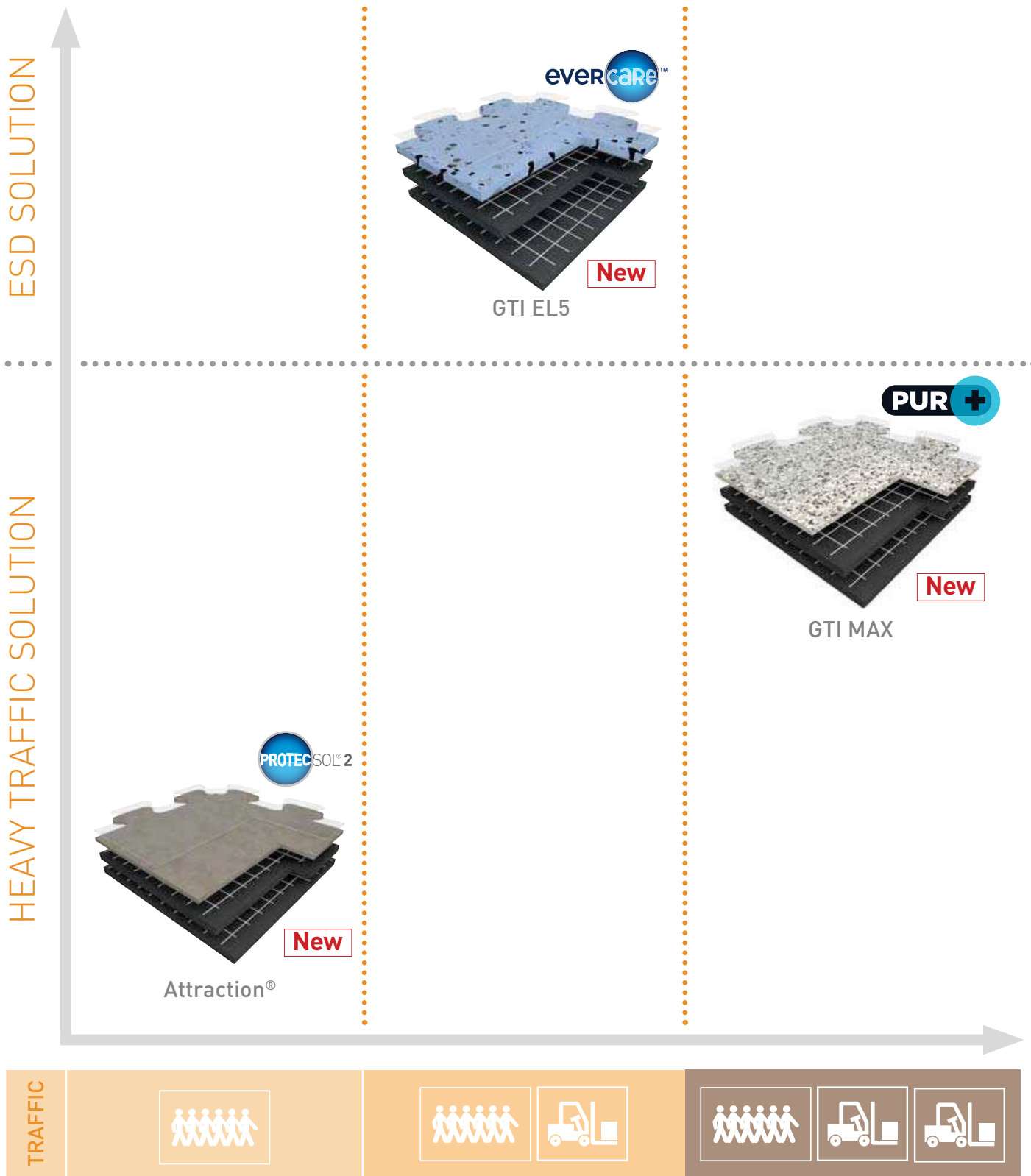

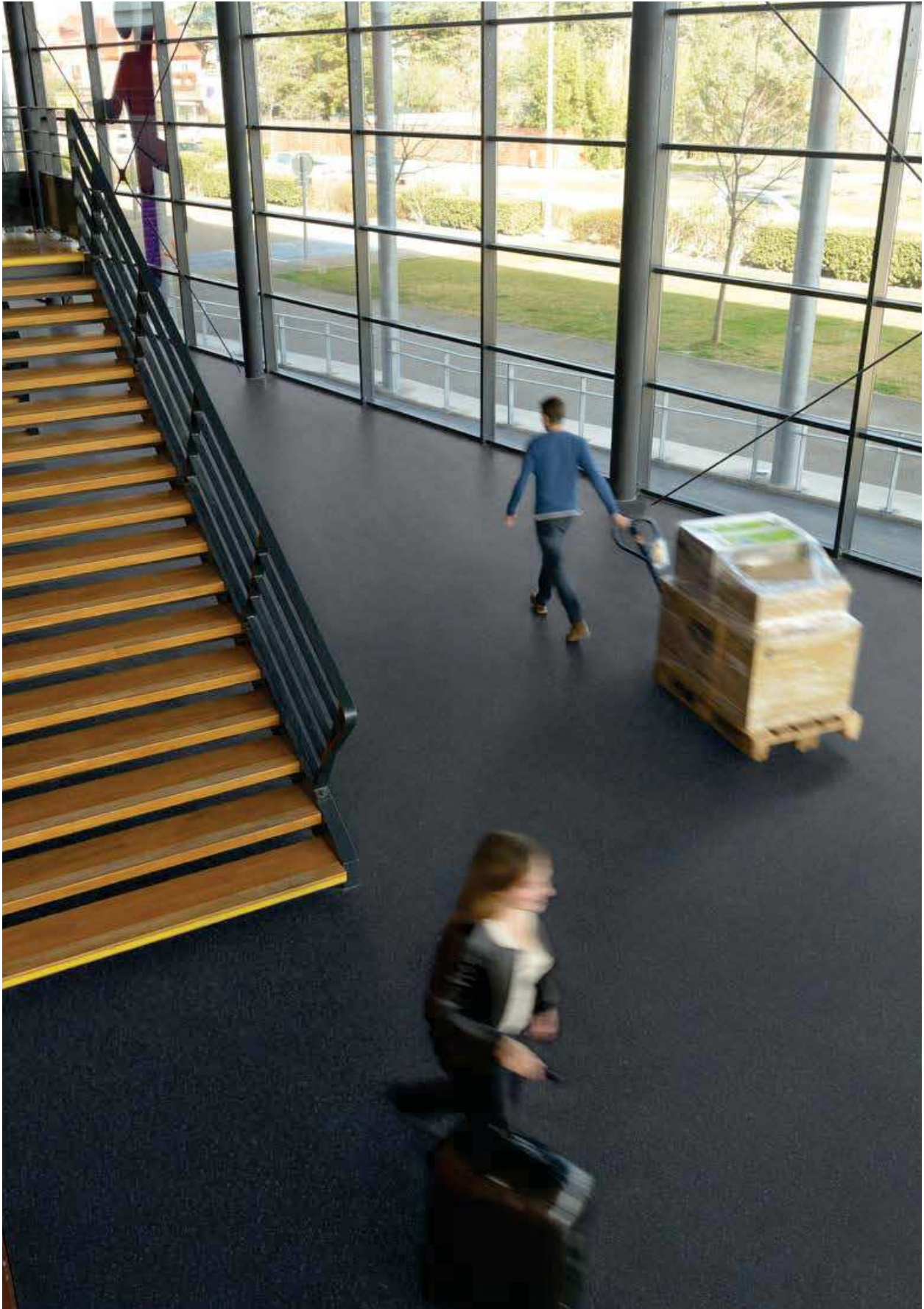

Fast Track
Looselay Tile

FAST TRACK LOOSELAY TILE

GTI MAX **NEW**

▶ GTI MAX CONNECT & CLEANTECH

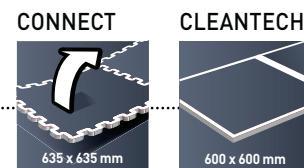

GTI CONNECT

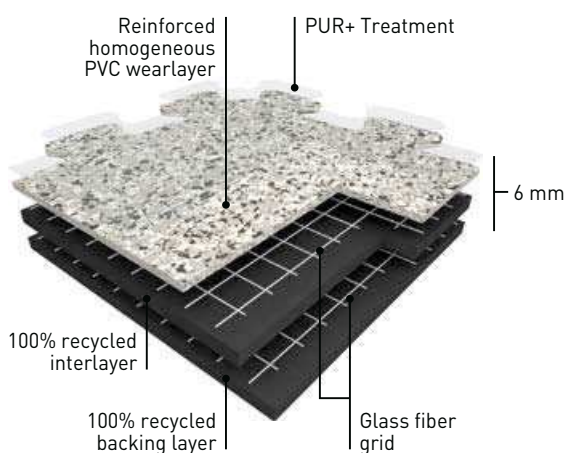

GTI MAX is a multi-layered interlocking looselay vinyl tile with polyurethane treatment (**PUR+**), 6 mm thick with a dovetail joint for the **CONNECT** configuration and with welded joints for the **CLEANTECH** configuration.

GTI is manufactured by Gerflor using a continuous high pressure process, abrasion group T. The **GTI MAX** wearlayer is reinforced by specific oblong fillers that offers an outstanding resistance to traffic.

GTI MAX is reinforced with 2 glass fibre grids on either side of an intermediate pressed homogeneous layer.

GTI MAX backing is a 4 mm thick black pressed homogeneous sheet, its surface is a coloured and reinforced homogeneous sheet 2 mm thick. The product is 100% recyclable.

GTI CLEANTECH

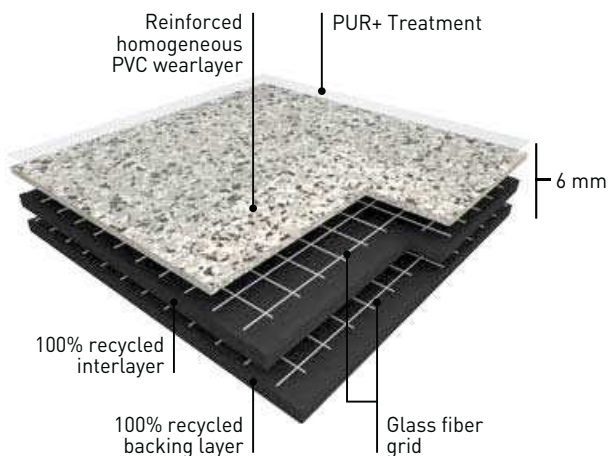

GTI Access are ramps that provide continuity between the tile and the existing floor.

GTI Corner enable covering of inaccessible corners or finishing central patterns.

GTI LOGOS



GTI MAX NEW



Removable

R10

PUR+



- ▶ **Resistant to heavy traffic**
- ▶ **Fast renovation: can be installed over existing floorcovering**
- ▶ **No subfloor preparation, no adhesive and no production stop (no loss of money)**
- ▶ **Polyurethane surface treatment PUR+ for ease of maintenance**
- ▶ **6 Standard logos: Mix and match colours to create corners and walkways**

| | | | GTI MAX | |
|--------------------------------------------|--------------------------|-------------------|------------------------------------------------------------------------------------|------------------------------------|
| DESCRIPTION | | | | |
| Total thickness | EN ISO 24346 [EN 428] | mm | 6 | |
| Wearlayer thickness | EN ISO 24340 [EN 429] | mm | 2 | |
| Weight | EN ISO 23997 [EN 430] | g/m ² | 9365 | |
| Size | EN ISO 24342 [EN 427] | mm | 635 x 635 GTI CONNECT 600 x 600 GTI CLEANTECH (without dovetail) ⁽¹⁾ | |
| CLASSIFICATION | | | | |
| Norm / Product specification | - | - | EN ISO 10582 [EN 649] | |
| European classification | EN ISO 10874 [EN 685] | class | 34-43 | |
| Fire rating | EN 13501-1 | class | Bfl-s1 | |
| Static electrical propensity | EN 1815 IEC 61340-4-5 | kV V | < 2 | |
| Slip resistance wet: ramp test with oil | DIN 51 130 | class | R10 | |
| Pendulum test | BS7976 | - | Concrete emboss ⁽²⁾ : HSE 36 compliant | Rice emboss ⁽²⁾ : NO |
| PERFORMANCES | | | | |
| Wear resistance | EN 660.2 | mm ³ | ≤ 2.0 | |
| Wear group | EN 649 | group | T | |
| Type Binder content | EN ISO 10582 | type | I | |
| Dimensional stability | EN ISO 23999 [EN 434] | % | ≤ 0.15 | |
| Residual indentation | EN ISO 24343-1 [EN 433] | mm | ≤ 0.10 | |
| Castor chair test (type W) | ISO 4918 [EN 425] | - | OK | |
| Shore Hardness | EN ISO 868 | H _b | ≥ 55 | |
| Shifting resistance | CAHIER CSTB 3562 | N/mm ² | ≥ 30 | |
| Thermal conductivity | EN ISO 10456 [EN 12 524] | W/(m.k) | 0.25 | |
| Colour fastness | EN 20 105 - B02 | degree | ≥ 6 | |
| Surface treatment | - | - | PUR+ | |
| Chemical products resistance | EN ISO 26987 [EN 423] | - | OK | |
| ENVIRONMENT / INDOOR AIR QUALITY | | | | |
| TVOC after 28 days | ISO 16000-6 | µg/m ³ | <100 | |
| Certification | - | - | Floorscore® | |
| CE MARKING | | | | |
| CE | EN 14041 | | | |
| | | | | |

Fast Track
Loose Lay Tile

(1) Available upon request
(2) See pages 198-199

FAST TRACK LOOSELAY TILE

GTI MAX **NEW** Rice Emboss

 **Compact CONNECT**
635 x 635 mm

 **Compact CLEANTECH**
600 x 600 mm

Removable | R10 | PUR+ |  100% recyclable

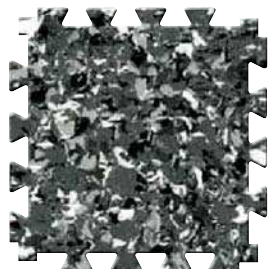

1249 - Tramontana

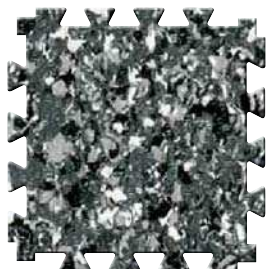

0249 - Carbon

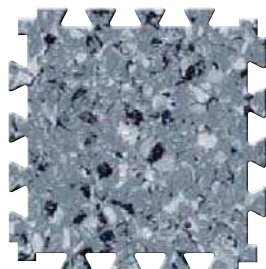

0252 - Titanium

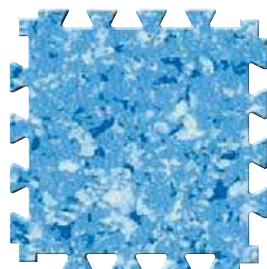

0255 - Saphir



0247 - Magma

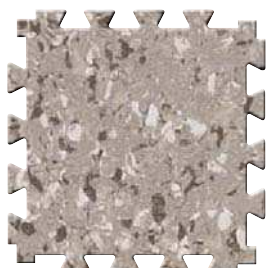

0267 - Levante



0264 - Ponente



0265 - Maestral

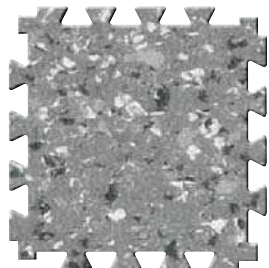

0266 - Peler



0253 - Aluminium



0236 - Black

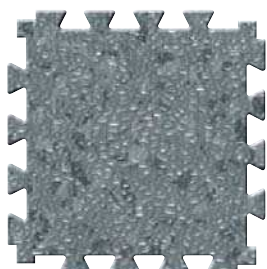

0235 - Dark Grey

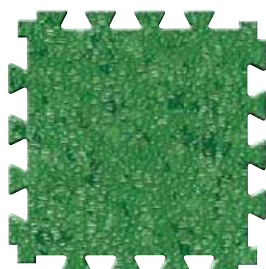

0233 - Green

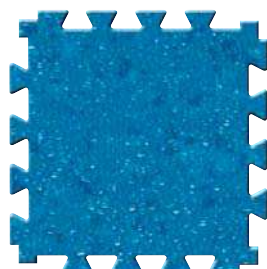

0230 - Blue

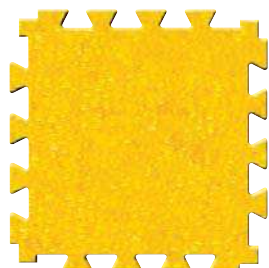

0231 - Yellow

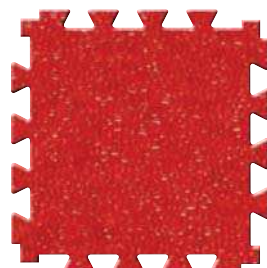

0232 - Red



0234 - Clear Grey

GTI MAX **NEW** Concrete Emboss



Removable

R10

PUR+



0260 - Ora

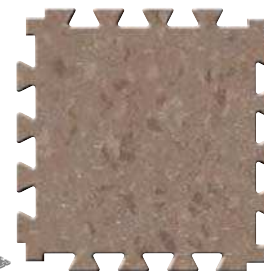

0261 - Scirocco

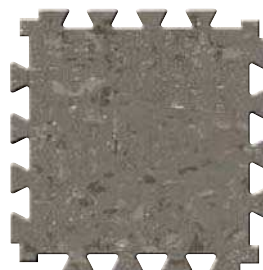

0262 - Libeccio

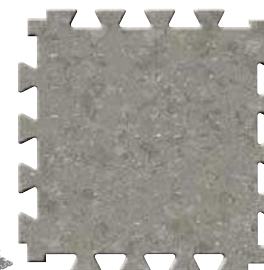

0259 - Grecale

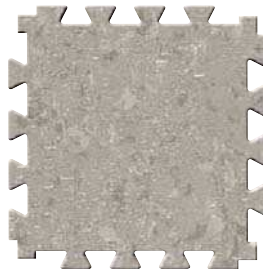

0263 - Bora

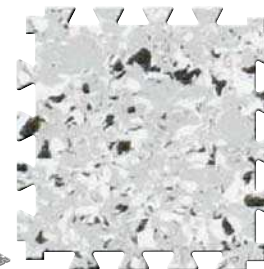

0268 - Ermellino

Fast Track
Looselay Tile

ACCESSORIES GTI MAX

LOOSELAY RAMP 5-6 MM

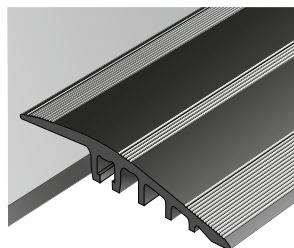

Aluminium Ramp 5-6 mm /
Ref. 0505
+ ALUMINIUM CORNER 5-6 mm /
Ref. 1513
See page 283

KIT ROMAT GT FOR GTI MAX



Ref. 1719
See page 287

CORNER & ACCESS

GTI CORNER CONNECT
320 x 320 mm



GTI ACCESS CONNECT
635 x 320 mm

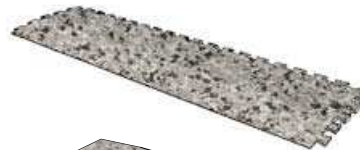

GTI CORNER CLEANTECH
300 x 300 mm

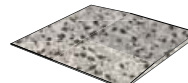

GTI ACCESS CLEANTECH
600 x 300 mm



For more information, please refer to our GTI MAX brochure.
Solutions for asbestos support, see page 306 "Safescape".

FAST TRACK LOOSELAY TILE

GTI EL5

▶ GTI EL5 CONNECT & CLEANTECH

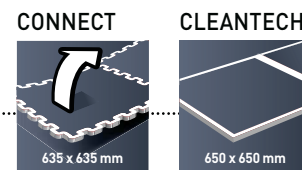

GTI EL5 CONNECT

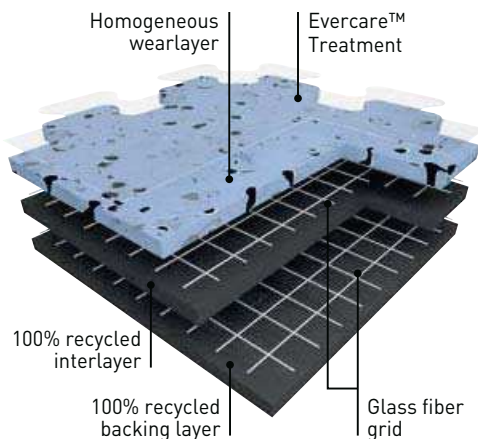

GTI EL5 CLEANTECH

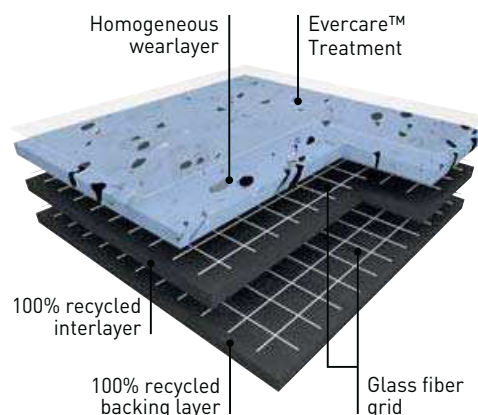

GTI EL5 is a multi-layered looselay vinyl tile, 6 mm thick, reinforced with 2 glass fibre grids.

GTI EL5 CONNECT tiles can be installed using interlocking system with dove tails.

GTI EL5 CLEANTECH is available in square format with welded joints for clean environments and watertight systems requirements.

GTI EL5 wearlayer is 2 mm vinyl homogeneous manufactured with continuous high pressure process, abrasion group P.

It offers an outstanding resistance to traffic.

This floorcovering is treated with **Evercare™** technology: the latest improvements in polyurethane surface treatment obtained by UV laser cross-linking. Evercare™ offers **easy maintenance and resistance against staining** of chemical products used in healthcare like betadine, eosin or anti-bacterial hand gel ; **and decontamination protocols.**

This treatment has excellent maintenance characteristics; it requires no wax for life!

The carbon encapsulated granules throughout its full thickness and the **conductive backing and conductive surface treatment** ensure optimal and consistent conductive properties throughout its full life expectancy:

- $5 \times 10^6 \leq Rt \leq 10^6$ according to **EN 1081**
- $Rt \leq 10^9$ according to **IEC 61.340-4-1**

It has permanent antistatic properties:

- < 2000V according to **EN 1815**
- < 100V according to **IEC 61.340-4-5**

The product is non-emissive of volatile organic compounds with <10 µg/m³ (TVOC after 28 days ISO 16000-6).

COMPLEMENTARY FINISHES:

GTI EL5 CLEANTECH ACCESS (access ramp), GTI EL5 CLEANTECH CORNER (corner finishes), GTI EL5 CLEANTECH COVING (COVING / COVING CORNER IN and COVING CORNER OUT) and conductive welding rods (GTI EL5 CLEANTECH WELDING RODS).

GTI EL5 CONNECT ACCESS (access ramp), GTI EL5 CONNECT CORNER (corner finishes).



GTI EL5



Removable

R9

Evercare™



CONNECT

- ▶ Fast Installation
- ▶ Resistance to heavy traffic

CLEANTECH

- ▶ Watertight System (hot welding)
- ▶ Resistance to heavy traffic

| | | | GTI EL5 |
|---------------------------------------------|---------------------------------------------------------------|-------------------|---------------------------------------------------------------------------------|
| DESCRIPTION | | | |
| Total thickness | EN ISO 24346 (EN 428) | mm | 6 |
| Wearlayer thickness | EN ISO 24340 (EN 429) | mm | 2 |
| Weight | EN ISO 23997 (EN 430) | g/m ² | 9240 |
| Size | EN ISO 24342 (EN 427) | mm | 635 x 635 (GTI EL5 CONNECT) 650 x 650 (GTI EL5 CLEANTECH) |
| CLASSIFICATION | | | |
| Norm / Product specification | - | - | EN ISO 10582 (EN 649) |
| European classification | EN ISO 10874 (EN 685) | class | 34-43 |
| Fire rating | EN 13501-1 | class | Bfl-s1 |
| Electrical resistance ⁽¹⁾ | EN 1081 IEC 61340-4-1 IEC 61340-4-5 ANSI/ESD STM 7.1 | W | $5 \times 10^4 \leq R_t \leq 10^6$ $\leq 10^9$ $\leq 10^9$ $\leq 10^9$ |
| Static electrical propensity | EN 1815 IEC 61340-4-5 | kV V | < 2 $\leq 100^{(2)}$ |
| Protection against electrostatic discharges | ESD S20.20 IEC 61340-5-1 | - - | OK OK |
| Slip resistance wet: ramp test with oil | DIN 51 130 | class | R9 |
| PERFORMANCES | | | |
| Wear resistance | EN 660.2 | mm ³ | ≤ 4.0 |
| Wear group | EN 649 | group | P |
| Type Binder content | EN ISO 10582 | type | I |
| Dimensional stability | EN ISO 23999 (EN 434) | % | ≤ 0.25 |
| Castor chair test (type W) | ISO 4918 (EN 425) | - | OK |
| Shore Hardness | EN ISO 868 | H _D | ≥ 90 |
| Thermal conductivity | EN ISO 10456 (EN 12 524) | W/(m.k) | 0.25 |
| Colour fastness | EN 20 105 - B02 | degree | ≥ 6 |
| Surface treatment | - | - | Evercare™ |
| Chemical products resistance | EN ISO 26987 (EN 423) | - | OK |
| ENVIRONMENT / INDOOR AIR QUALITY | | | |
| TVOC after 28 days | ISO 16000-6 | µg/m ³ | <10 |
| Certification | - | - | Floorscore® |
| CE MARKING | | | |
| CE | EN 14041 | | |
| | | | |

(1) Measured before installation

(2) Measured with ESD shoes (type ABEBA and Uvex)

FAST TRACK LOOSELAY TILE

GTI EL5

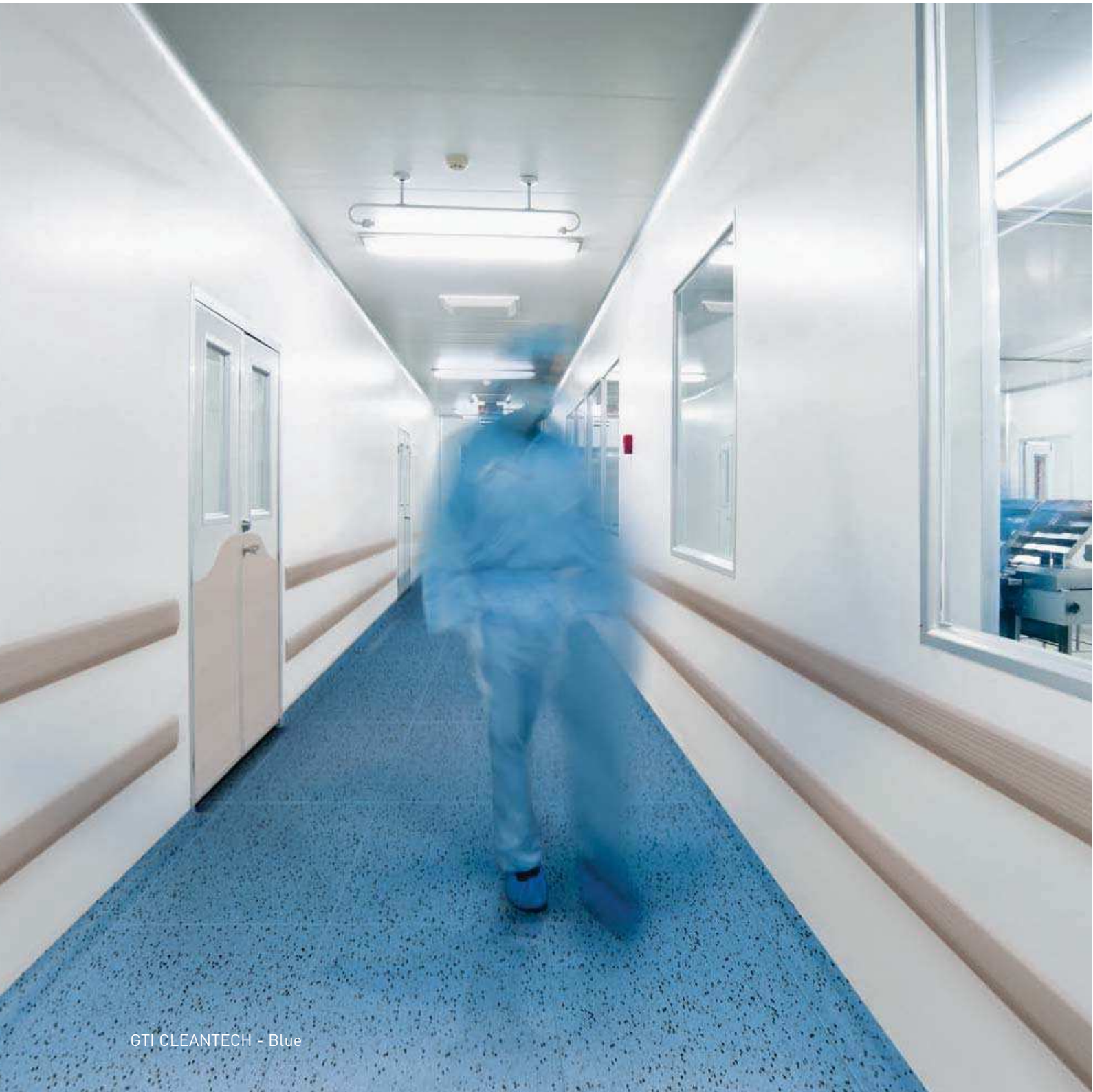

GTI CLEANTECH - Blue

GTI EL5

GTI EL5 CONNECT



R9

Evercare™

Removable

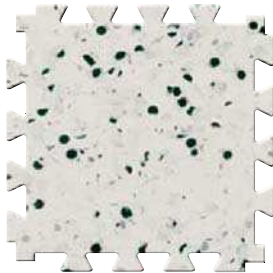

0350 Light Grey

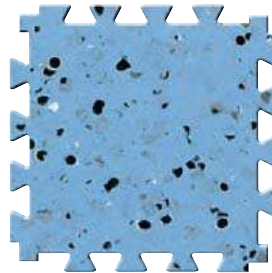

0354 Blue

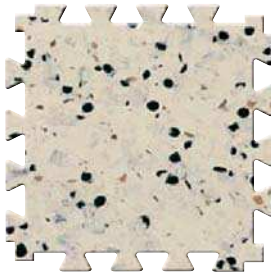

0353 Beige

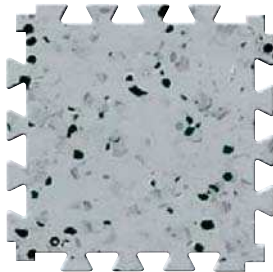

0352 Grey

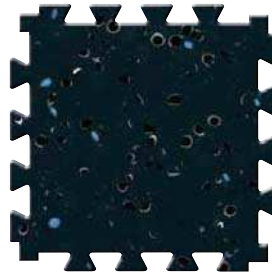

0351 Black

GTI EL5 CLEANTECH



R9

Evercare™

Removable

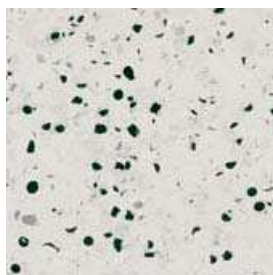
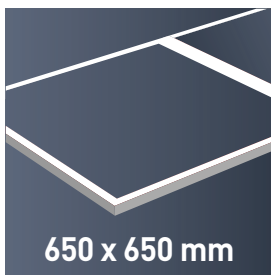

0350 Light Grey

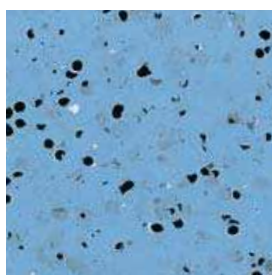

0354 Blue

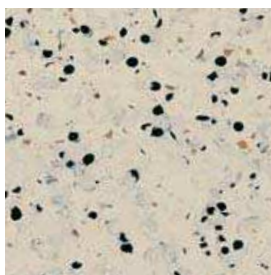

0353 Beige

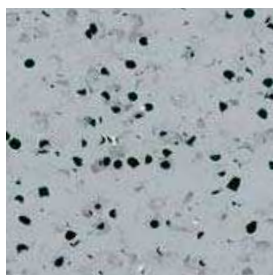

0352 Grey

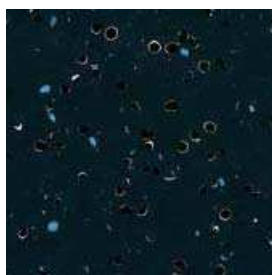

0351 Black

Fast Track
Looselay Tile

FAST TRACK LOOSELAY TILE

ATTRACTION® **NEW**

▶ **ATTRACTION® CONNECT & CLEANTECH**

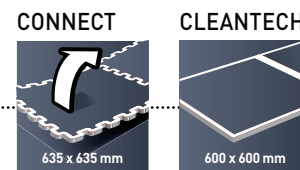

ATTRACTION® CONNECT

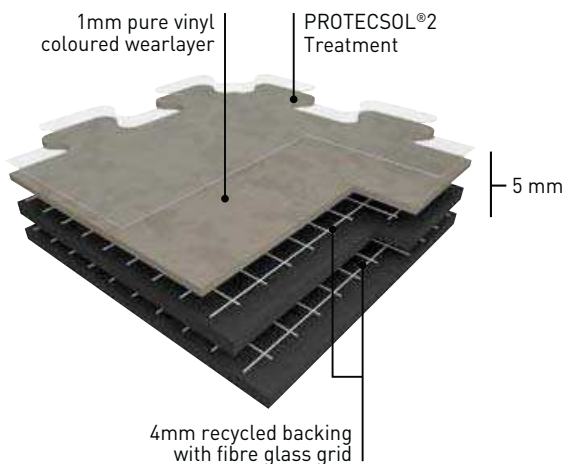

ATTRACTION® is a semi-flexible tile constructed by compacting, at high temperature and over 3000 T, a 4mm recycled backing and a 1mm **pure vinyl wear layer**. **This wear layer is incorporating very densely pressed coloured chips, with a mat finishing and without a transparent wear layer.** The product comprises a compact backing which is pressed and reinforced with two glass fibre grids.

ATTRACTION® has a unique dovetail joint which allows fast loose lay installation and replacement.

ATTRACTION® is treated with **Protecsol®2**, a surface treatment obtained by UV laser crosslinking.

This Protecsol®2 ensures easy maintenance and eliminates permanently the need for acrylic emulsion (metallisation). It avoids staining of chemical products used in healthcare like iodine alcohol, Betadine, eosin and anti-bacterial hand gel.

It has a Bfl-s1 fire classification in accordance with standard EN 13501-1. The products emission rate of volatile organic compounds is **<10µg/m³ (TVOC after 28 days - ISO 16000-6)**.

It is made of 100% controlled recycled materials.

It does not contain any heavy metals or CMR 1&2 and they are 100% compliant with REACH.

It is 100% recyclable and made with up to 80% recycled content.

ATTRACTION® CLEANTECH

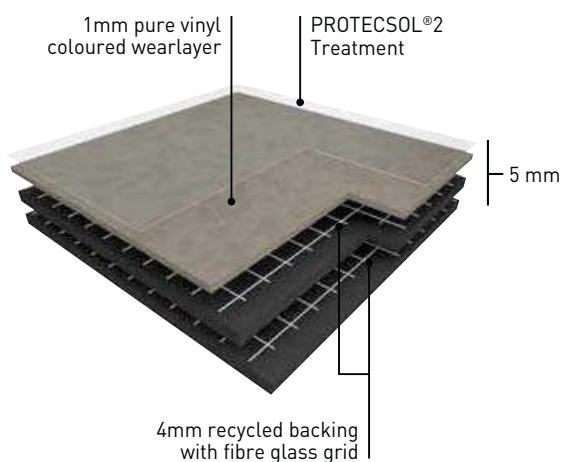

ATTRACTION® NEW



The Taralay Premium range in the looseley Attraction® format for an easy and longlasting renovation!

- ▶ Fast track and easy installation
- ▶ No immobilisation of the premises and no loss of turnover
- ▶ Little or no subfloor preparation
- ▶ Low maintenance cost: UV cured polyurethane PUR+ treatment.

| | | | ATTRACTION® |
|-----------------------------------------|--------------------------|-------------------|----------------------------------------------------------------------------|
| DESCRIPTION | | | |
| Total thickness | EN ISO 24346 (EN 428) | mm | 5.00 |
| Wearlayer thickness | EN ISO 24340 (EN 429) | mm | 1.00 |
| Weight | EN ISO 23997 (EN 430) | g/m ² | 7460 |
| Size | EN ISO 24342 (EN 427) | mm | 635 x 635 CONNECT 600 x 600 CLEANTECH (without dovetail) ^[1] |
| CLASSIFICATION | | | |
| Norm / Product specification | - | - | EN ISO 10582 (EN 649) |
| European classification | EN ISO 10874 (EN 685) | class | 34-43 |
| Fire rating | EN 13501-1 | class | Bfl-s1 |
| Static electrical propensity | EN 1815 IEC 61340-4-5 | kV V | <2 |
| Slip resistance wet: ramp test with oil | DIN 51 130 | class | R10 |
| PERFORMANCES | | | |
| Wear resistance | EN 660.2 | mm ³ | ≤ 2.0 |
| Wear group | EN 649 | group | T |
| Type Binder content | EN ISO 10582 | type | I |
| Dimensional stability | EN ISO 23999 (EN 434) | % | ≤ 0.25 |
| Residual indentation | EN ISO 24343-1 (EN 433) | mm | ≤ 0.10 |
| Castor chair test (type W) | ISO 4918 (EN 425) | - | OK |
| Thermal conductivity | EN ISO 10456 (EN 12 524) | W/(m.k) | 0.25 |
| Colour fastness | EN 20 105 - B02 | degree | ≥ 6 |
| Surface treatment | - | - | ProtecSol®2 |
| Chemical products resistance | EN ISO 26987 (EN 423) | - | OK |
| ENVIRONMENT / INDOOR AIR QUALITY | | | |
| TVOC after 28 days | ISO 16000-6 | µg/m ³ | <10 |
| Certification | - | - | Floorscore® |
| CE MARKING | | | |
| | EN 14041 | | |
| | | | |

Fast Track
Looseley Tile

[1] Available upon request

FAST TRACK LOOSELAY TILE

ATTRACTION® **NEW**

Compact CONNECT 635 x 635 mm | Compact CLEANTECH 600 x 600 mm | Removable | R10 | ProtecSol®2 | 100% recyclable



8386 Boa Vista (Brazilia)

4342 Juara (Brazilia)

4343 Tokelau (Indiana)

4351 Greige (Osmoz)

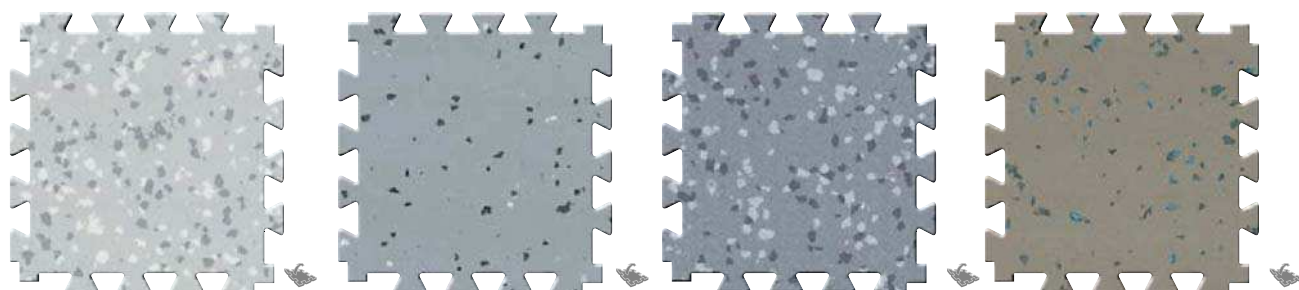

8736 Recife (Brazilia)

4003 Tao (Indiana)

3709 Ceara (Brazilia)

8053 Anambas (Indiana)

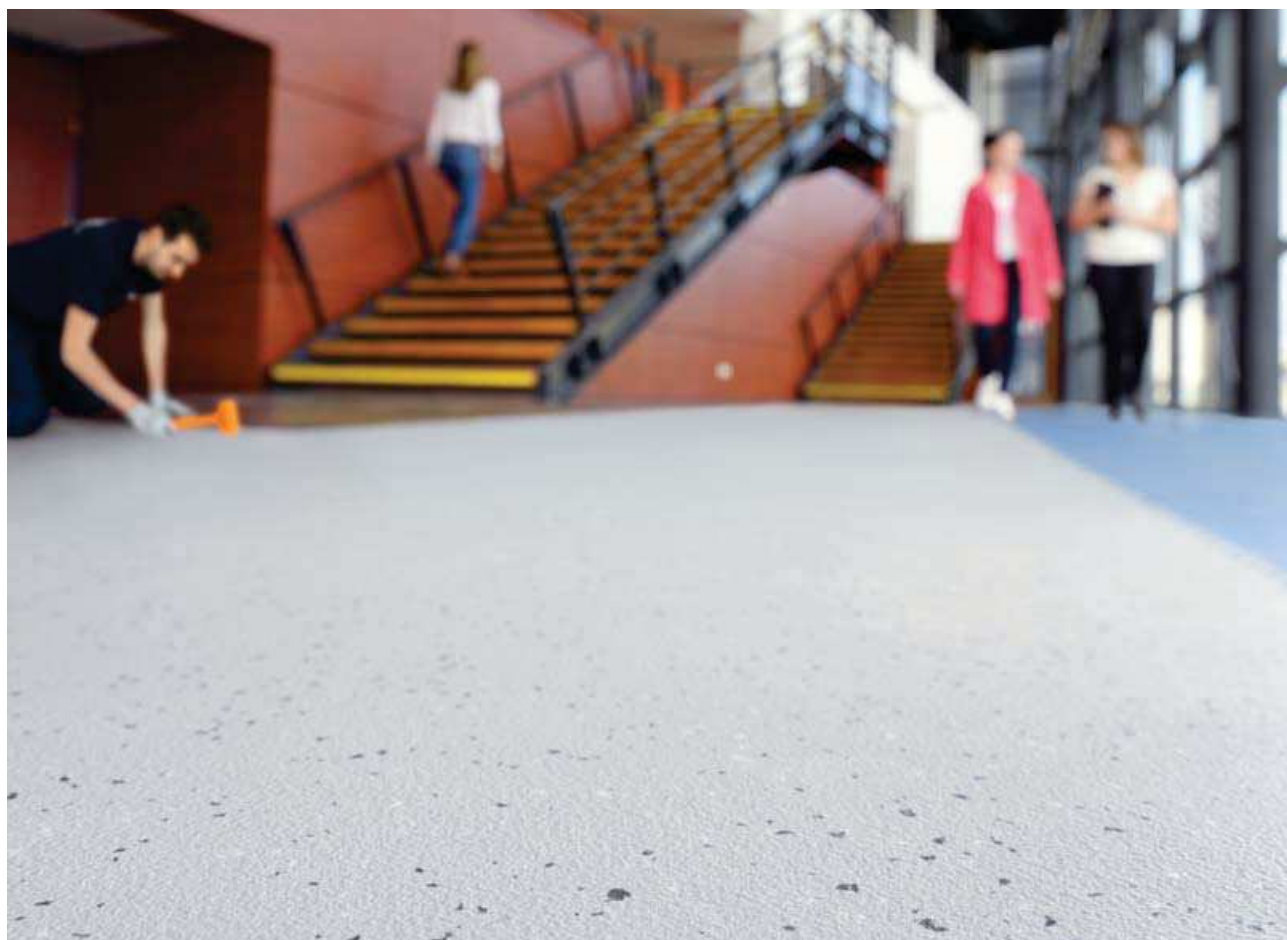

ATTRACTION® NEW

| | | | | | |
|----------------------------------------------------------------------------------------------------------------------|------------------------------------------------------------------------------------------------------------------------|-----------|-----|--------------|---------------------------------------------------------------------------------------------------|
|  Compact CONNECT 635 x 635 mm |  Compact CLEANTECH 600 x 600 mm | Removable | R10 | Protectsol®2 |  100% recyclable |
|----------------------------------------------------------------------------------------------------------------------|------------------------------------------------------------------------------------------------------------------------|-----------|-----|--------------|---------------------------------------------------------------------------------------------------|

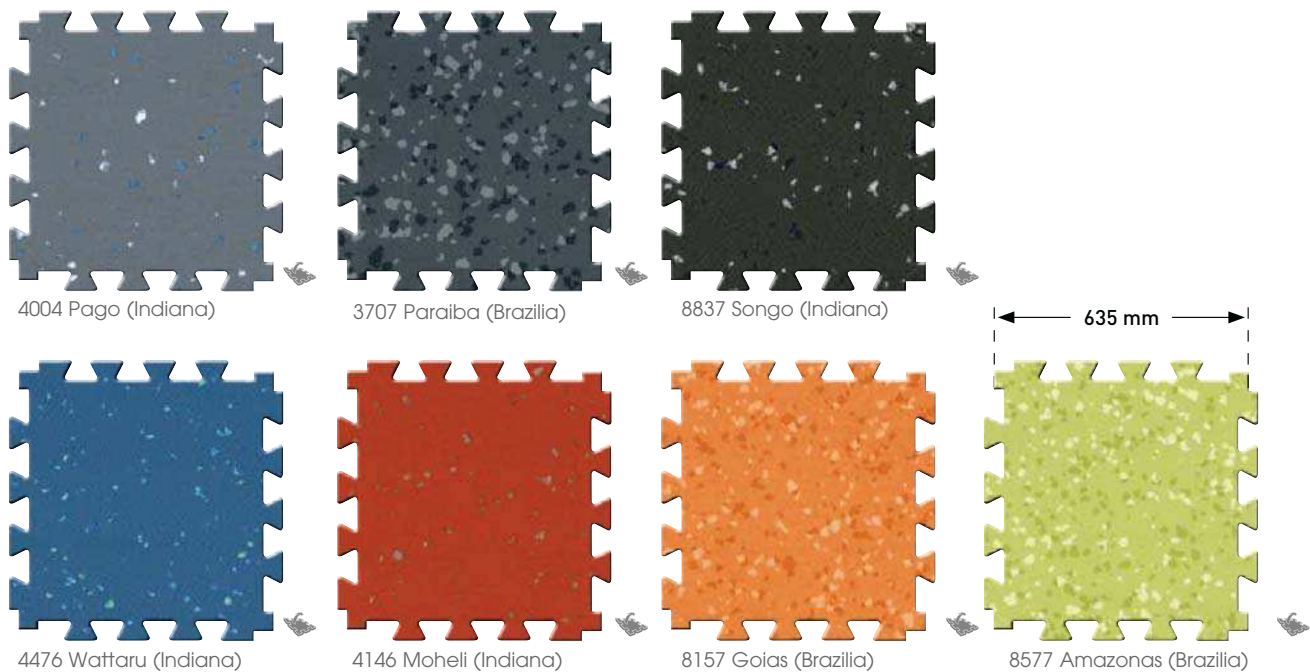

Fast Track
Looselay Tile

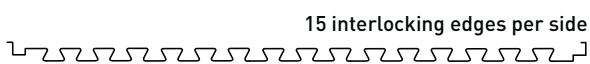

All these colours are available in ATTRACTION® CLEANTECH.

ACCESSORIES ATTRACTION®

LOOSELAY RAMP 5-6 MM

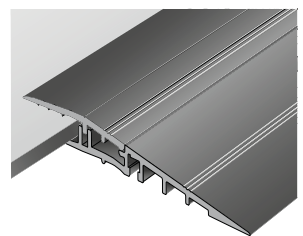

Aluminium Ramp 5-6 mm /
Ref. 0609
+ ALUMINIUM CORNER 5-6 mm /
Ref. 0629
See page 283

KIT ROMAT GT FOR ATTRACTION®



Ref. 1719
See page 287

CORNER & ACCESS

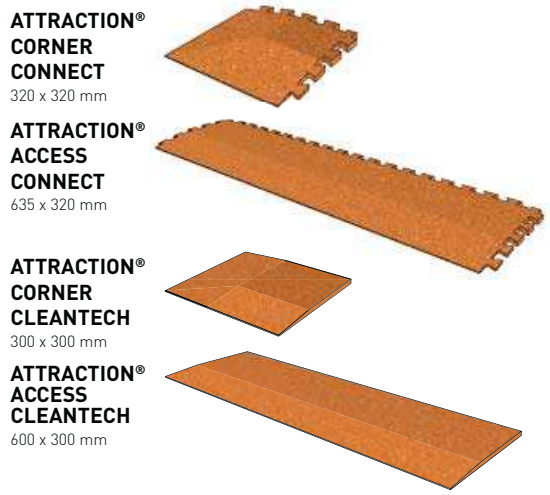

**ATTRACTION®
CORNER
CONNECT**
320 x 320 mm

**ATTRACTION®
ACCESS
CONNECT**
635 x 320 mm

**ATTRACTION®
CORNER
CLEANTECH**
300 x 300 mm

**ATTRACTION®
ACCESS
CLEANTECH**
600 x 300 mm

For more information, please refer to our Attraction® brochure. Solutions for asbestos support, see page 306 "Safescape".



SPECIALITY
FLOORING
AND
WALLCOVERING

PAGES

208 / 235



ESD solution

(Static control flooring)212-217

- Mipolam Accord EL7 **NEW** 214
- Mipolam Robust EL7 214
- Mipolam Elegance EL5 **NEW** 215
- Mipolam Technic EL5 215
- GTI EL5 216

Safety flooring218-225

- Tarasafe Geo
SparClean® 221
- Tarasafe Ultra & Ultra
Comfort SparClean® 223
- Tarasafe Ultra H2O 224
- Tarasafe Standard/
Plus/Super 225

Taradouche Shower System226-231

- Elegance SD 228
- Tarasafe Ultra H₂O 228
- Mural Calypso 229

Wallcovering232-235

- Mural Ultra 234
- Mural Club 234
- Mural Calypso 235

SPECIALITY FLOORING

ESD SOLUTIONS

Dissipative Flooring

EN 1081 (Ω): $10^6 \leq Rt \leq 10^8$

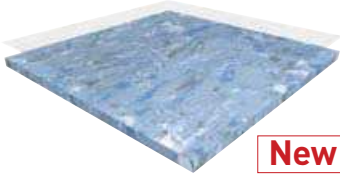

New

Mipolam Accord EL7

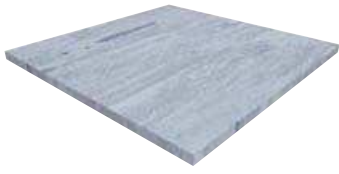

Mipolam Robust EL7

SLIP RESISTANT FLOORING

SparClean® Treatment

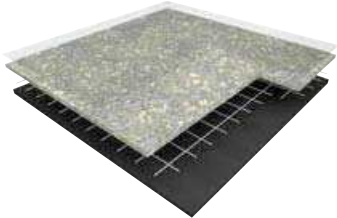

Tarasafe Geo /
Tarasafe Ultra

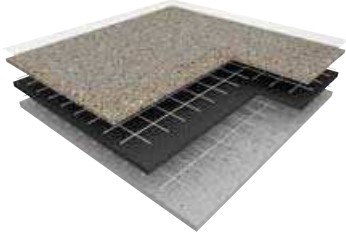

Tarasafe Ultra Comfort

SHOWER SYSTEM

Floorcovering



Elegance SD

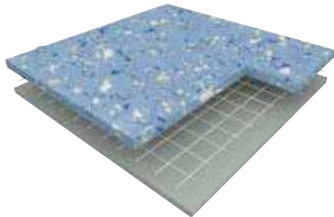

Tarasafe Ultra H₂O

WALL COVERING



Mural Ultra

Conductive Flooring

EN 1081 (Ω): $10^4 \leq R_t \leq 10^6$



New

Mipolam Elegance EL5

EN 1081 (Ω): $10^4 \leq R_t \leq 10^6$

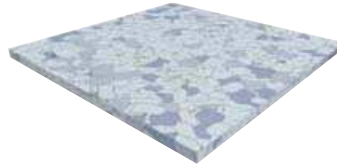

Mipolam Technic EL5

EN 1081 (Ω): $5 \times 10^4 \leq R_t \leq 10^6$

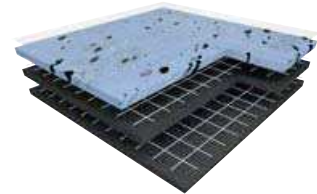

GTI EL5

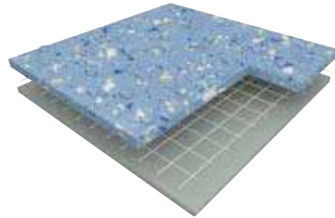

Tarasafe Ultra H₂O



Tarasafe Standard
Tarasafe Super & Plus

Wall Covering

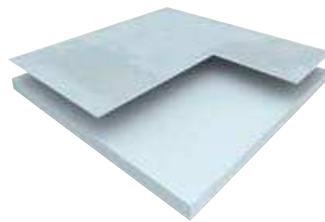

Mural Calypso



Mural Club

SPECIALITY FLOORING

ESD SOLUTIONS - MIPOLAM EL

Dissipative flooring

▶ MIPOLAM ACCORD EL7 - MIPOLAM ROBUST EL7

MIPOLAM ACCORD EL7 **NEW**

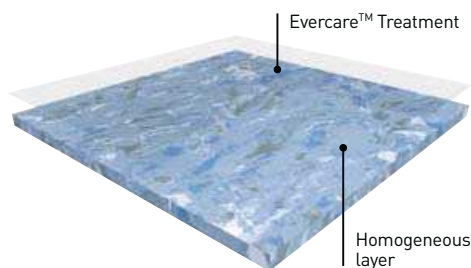

P | $10^6 \leq Rt \leq 10^8 \Omega$ | Evercare™ | 100% recyclable

MIPOLAM ACCORD EL7 is a dissipative flexible homogeneous vinyl floorcovering available in both sheet and tile. Calendered and compacted.

This floorcovering is treated with **Evercare™**: the latest improvements in polyurethane surface treatment obtained by UV laser cross-linking. Evercare™ avoids stain of chemical products used in healthcare like betadine, eosin or anti-bacterial hand gel and increases the durability of the flooring. This treatment has excellent maintenance characteristics; it requires no wax for life!

MIPOLAM ACCORD EL7 acts as a continuous dissipater $10^6 \leq Rt \leq 10^8$.

The product is non-reactive to residual indentation with a value $\leq 0,02$ mm.

The flooring is a group P wear rating suitable for heavy duty traffic areas and Bfl-s1 fire resistance. The product is non-emissive of volatile organic compounds with $< 10 \mu\text{g}/\text{m}^3$ (TVOC after 28 days ISO 16000-6).

MIPOLAM ROBUST EL7

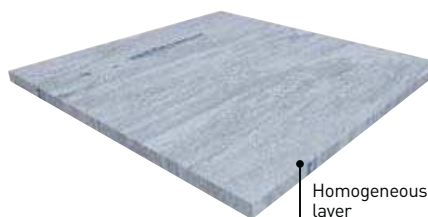

M | $10^6 \leq Rt \leq 10^8 \Omega$ | 100% recyclable

MIPOLAM ROBUST EL7 is a dissipative flexible homogeneous vinyl floorcovering available in both sheet and tile. Calendered and compacted. It acts as a continuous dissipater $10^6 < Rt < 10^8$ (EN 1081).

Conductive flooring

▶ MIPOLAM ELEGANCE EL5 - MIPOLAM TECHNIC EL5



MIPOLAM ELEGANCE EL5 **NEW**

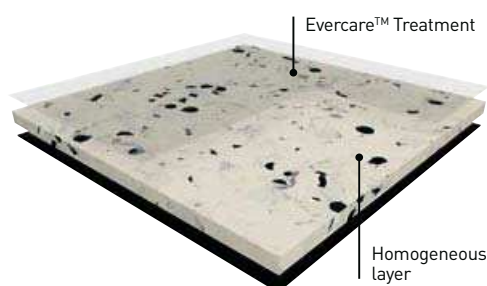

P | $10^4 \leq Rt \leq 10^6 \Omega$ | Evercare™ | 100% recyclable

MIPOLAM ELEGANCE EL5 is a conductive flexible homogeneous vinyl floorcovering available in sheet. The 2 mm homogeneous material incorporates carbon encapsulated granules throughout its full thickness. It has a **conductive backing** to ensure optimal and consistent conductive properties throughout its full life expectancy. This floorcovering is treated with **Evercare™**: the latest improvements in polyurethane surface treatment obtained by UV laser cross-linking. Evercare™ avoids stain of chemical products used in healthcare like betadine, eosin or anti-bacterial hand gel and increases the durability of the flooring. This treatment has excellent maintenance characteristics; it requires no wax for life!

MIPOLAM ELEGANCE EL5 acts as a continuous conductive $10^4 \leq Rt \leq 10^6$. It has permanent antistatic properties (< 100 V). The product has to be grounded with an ESD copper strip (cf. finishes) to meet its full performance. The product is non-reactive to residual indentation with a value $\leq 0,02$ mm. The flooring is a group P wear rating suitable for heavy duty traffic areas and Bfl-s1 fire resistance. The product is non-emissive of volatile organic compounds with $< 10 \mu\text{g}/\text{m}^3$ (TVOC after 28 days ISO 16000-6).

MIPOLAM TECHNIC EL5

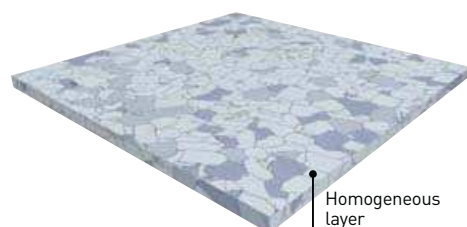

P | $10^4 \leq Rt \leq 10^6 \Omega$ | 100% recyclable

MIPOLAM TECHNIC EL5 is a conductive flexible homogeneous compacted vinyl floorcovering available in tiles.

The conductive carbon coated PVC pellets create a perfect conductive network for permanent conductive properties and antistatic properties (< 100 V) throughout its full life expectancy.

It acts as a continuous conductive $10^4 \leq Rt \leq 10^6$ (EN 1081).

ESD SOLUTIONS - MIPOLAM EL



100% recyclable

A complete range for Hi-tech applications: electronics and telecommunication areas, computer rooms, operating theatres, radiology...

- ▶ **Compacted floorcovering for better hygiene, maintenance, and traffic resistance.**
- ▶ **Available in tiles and sheets with specific formats especially adapted to raised floors (608 x 608 mm).**

| | | | MIPOLAM ELEGANCE EL5 | MIPOLAM TECHNIC EL5 | MIPOLAM ACCORD EL7 | MIPOLAM ROBUST EL7 |
|---------------------------------------------|-----------------------------------------------------------------|---------------------|-------------------------------------------------------------------------------------------------------|---------------------------------------------------------------------------------------|-------------------------------------------------------|-------------------------------------------------------|
| DESCRIPTION | | | | | | |
| Total thickness | EN ISO 24346 [EN 428] | mm | 2 | 2 | 2 | 2 |
| Weight | EN ISO 23997 [EN 430] | g/sq.m | 3060 | 3800 | 3100 | 3300 |
| Width of sheet | EN ISO 24341 [EN 426] | cm | 200 | - | 200 | 200 |
| Length of sheet | EN ISO 24341 [EN 426] | lm | 20 | - | 20 | 20 |
| Tile size | EN ISO 24342 [EN 427] | mm | - | 608 x 608 | 608 x 608 | 608 x 608 |
| Number of tiles per package | - | - | - | 20 | 20 | 20 |
| CLASSIFICATION | | | | | | |
| Norm / Product specification | - | - | EN ISO 10581 [EN 649] | EN ISO 10581 [EN 649] | EN ISO 10581 [EN 649] | EN ISO 10581 [EN 649] |
| European classification | EN ISO 10874 [EN 685] | class | 34-43 | 34-43 | 34-43 | 34-43 |
| Fire rating | EN 13501-1 | class | B _f -s1 | B _f -s1 | B _f -s1 | B _f -s1 |
| Electrical resistance ⁽¹⁾ | EN 1081 IEC 61340-4-1 IEC 61340-4-5 ANSI / ESD-STM 7.1 | Ohm | 10 ⁴ ≤ Rt ≤ 10 ⁶ ≤ 10 ⁹ ≤ 10 ⁹ ≤ 10 ⁹ | 10 ⁴ ≤ Rt ≤ 10 ⁶ ≤ 10 ⁹ - ≤ 10 ⁹ | 10 ⁶ ≤ Rt ≤ 10 ⁸ - - - | 10 ⁴ ≤ Rt ≤ 10 ⁸ - - - |
| Static electrical propensity | EN 1815 IEC 61340-4-5 | kV V | < 2 ≤ 100 ⁽²⁾ | < 2 < 100 ⁽²⁾ | < 2 - | < 2 - |
| Protection against electrostatic discharges | ESD 20.20 IEC 61340-5-1 | - - | OK OK | OK OK | - - | - - |
| Slip resistance wet ⁽³⁾ | DIN 51 130 | class | R9 | - | R9 | - |
| PERFORMANCES | | | | | | |
| Wear resistance | EN 660.2 | mm ³ | ≤ 4.0 | ≤ 4.0 | ≤ 4.0 | ≤ 7.5 |
| Wear group | NF 189 | - | P | P | P | M |
| Type Binder content | EN ISO 10581 | type | I | II | II | II |
| Dimensional stability | EN ISO 23999 [EN 434] | % | ≤ 0.40 | ≈ 0.25 | Sheet ≤ 0.40 Tile ≤ 0.25 | Sheet ≤ 0.40 Tile ≤ 0.25 |
| Residual indentation | EN ISO 24343-1 [EN 433] | mm | ≈ 0.02 | ≈ 0.03 | ≈ 0.02 | ≈ 0.03 |
| Castor chair test (type W) | ISO 4918 [EN 425] | - | OK | OK | OK | OK |
| Thermal conductivity | EN ISO 10456 [EN 12524] | W/(m.k) | 0.25 | 0.25 | 0.25 | 0.25 |
| Colour fastness | EN 20 105 - B02 | degree | ≥ 6 | ≥ 6 | ≥ 6 | ≥ 6 |
| Surface treatment | - | - | Evercare™ | - | Evercare™ | - |
| Chemical products resistance ⁽⁴⁾ | EN ISO 26987 [EN 423] | - | OK | OK | OK | OK |
| ENVIRONMENT / INDOOR AIR QUALITY | | | | | | |
| TVOC after 28 days | ISO 16000-6 | µg / m ³ | <10 | <10 | <10 | <10 |
| Certification | - | - | Floorscore® | - | Floorscore® | - |
| CE MARKING | | | | | | |
| CE | EN 14041 | | | | | |
| | | | | | | |

Speciality Flooring

(1) Measured before installation.

(2) Measured with ESD shoes (ABEBA and Uvex).

(3) For lifetime sustainable wet resistance, please refer to Tarasafe ranges.

(4) Staining table available upon request.

Important: please refer to Gerflor installation guidelines - www.gerflor.com

SPECIALITY FLOORING

MIPOLAM EL ACCORD EL7 - ROBUST EL7

MIPOLAM ACCORD EL7

NEW



P

$10^6 \leq Rt \leq 10^8 \Omega$

Evercare™



100% recyclable



3113 Manitoba



3111 Huron



3147 Grunsee



3150 Thames

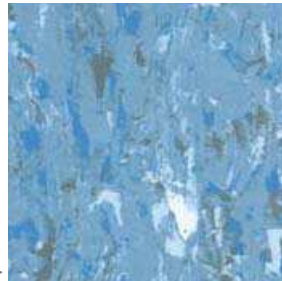

3116 Mälaren

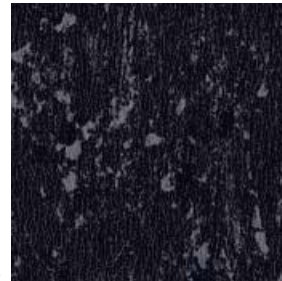

3160 Balaton

MIPOLAM ROBUST EL7



M

$10^6 \leq Rt \leq 10^8 \Omega$



100% recyclable



0003 Ivory



0002 Platinum



0112 Storm



0306 Green



0005 Steel



0013 Pewter

MIPOLAM EL ELEGANCE EL5 - TECHNIC EL5

MIPOLAM ELEGANCE EL5 **NEW**  **P** | $10^4 \leq Rt \leq 10^6 \Omega$ | Evercare™ |  100% recyclable

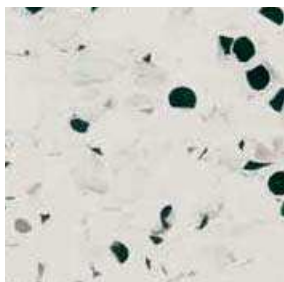

0350 Light Grey

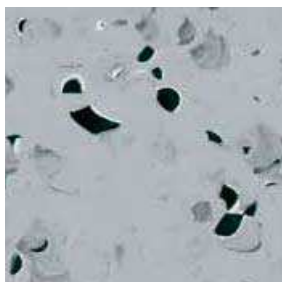

0352 Grey

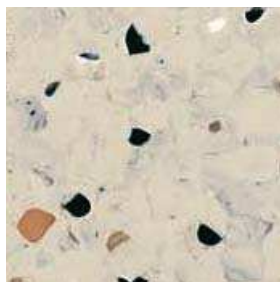

0353 Beige

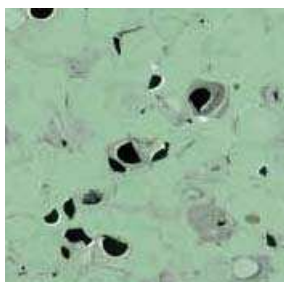

0355 Green

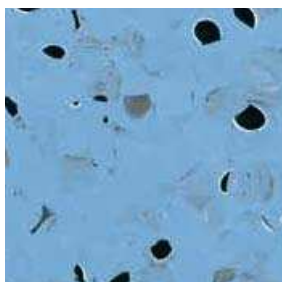

0354 Blue

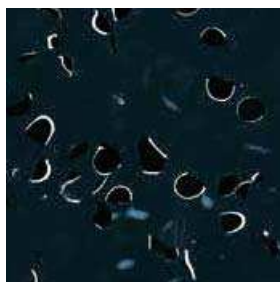

0351 Black

MIPOLAM TECHNIC EL5

 **P** | $10^4 \leq Rt \leq 10^6 \Omega$ |  100% recyclable



0635 White

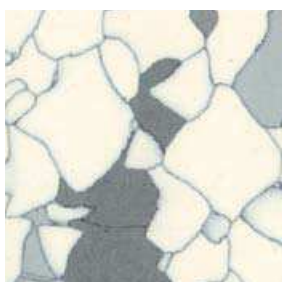

0636 Grey

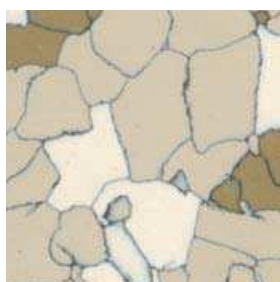

0640 Beige

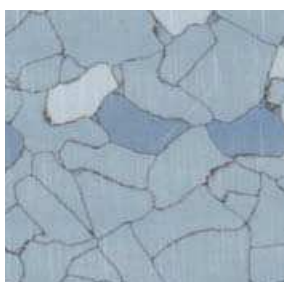

0638 Blue

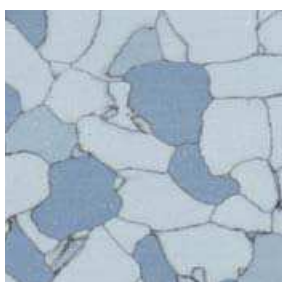

0637 Light Blue

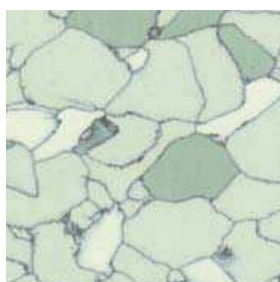

0639 Green

SPECIALITY FLOORING

ESD SOLUTIONS - GTI EL5

▶ GTI EL5 CONNECT & CLEANTECH

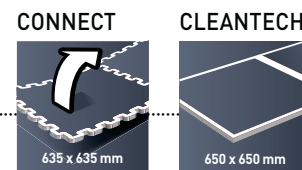

GTI EL5 CONNECT

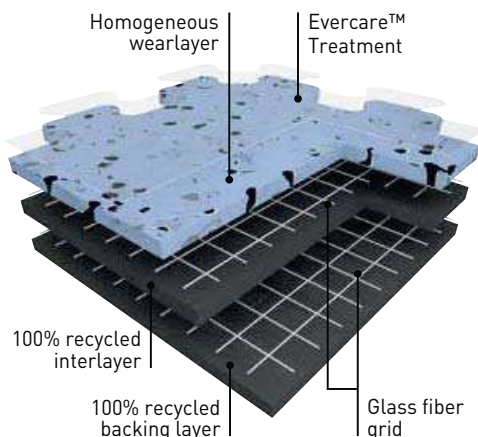

GTI EL5 CLEANTECH

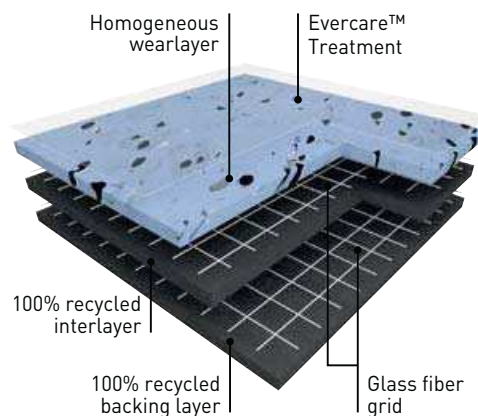

GTI EL5 is a multi-layered looselay vinyl tile, 6 mm thick, reinforced with 2 glass fibre grids.

GTI EL5 CONNECT tiles can be installed using interlocking system with dove tails.

GTI EL5 CLEANTECH is available in square format with welded joints for clean environments and watertight systems requirements.

GTI EL5 wearlayer is 2 mm vinyl homogeneous manufactured with continuous high pressure process, abrasion group P.

It offers an outstanding resistance to traffic.

This floorcovering is treated with **Evercare™** technology: the latest improvements in polyurethane surface treatment obtained by UV laser cross-linking. Evercare™ offers **easy maintenance and resistance against staining** of chemical products used in healthcare like betadine, eosin or anti-bacterial hand gel ; **and decontamination protocols**.

This treatment has excellent maintenance characteristics; it requires no wax for life!

The carbon encapsulated granules throughout its full thickness and the **conductive backing and conductive surface treatment** ensure optimal and consistent conductive properties throughout its full life expectancy:

- $5 \times 10^4 \leq Rt \leq 10^6$ according to **EN 1081**
- $Rt \leq 10^9$ according to **IEC 61.340-4-1**

It has permanent antistatic properties:

- < 2000V according to EN 1815
- < 100V according to IEC 61.340-4-5

The product is non-emissive of volatile organic compounds with <math>< 10 \mu\text{g}/\text{m}^3</math> (TVOC after 28 days ISO 16000-6).

COMPLEMENTARY FINISHES:

GTI EL5 CLEANTECH ACCESS (access ramp), GTI EL5 CLEANTECH CORNER (corner finishes), GTI EL5 CLEANTECH coving (COVING / COVING CORNER IN and COVING CORNER OUT) and conductive welding rods (GTI EL5 CLEANTECH WELDING RODS).

GTI EL5 CONNECT ACCESS (access ramp), GTI EL5 CONNECT CORNER (corner finishes).

CONNECT

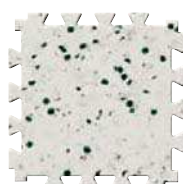
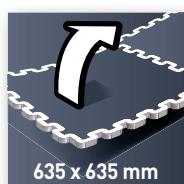

0350 Light Grey

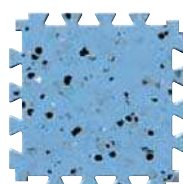

0354 Blue



0353 Beige



0352 Grey

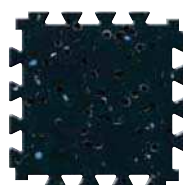

0351 Black

CLEANTECH

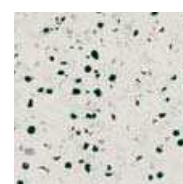
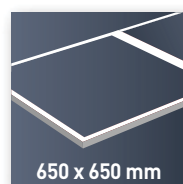

0350 Light Grey

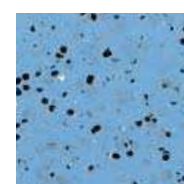

0354 Blue

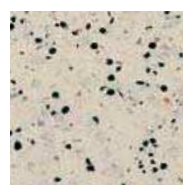

0353 Beige

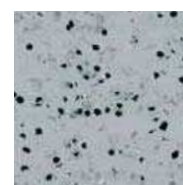

0352 Grey



0351 Black

ESD SOLUTIONS - GTI EL5



Removable

R9

Evercare™



CONNECT

- ▶ Fast Installation
- ▶ Resistance to heavy traffic

CLEANTECH

- ▶ Watertight System (hot welding)
- ▶ Resistance to heavy traffic

| | | | GTI EL5 |
|---------------------------------------------|---------------------------------------------------------------|-------------------|---------------------------------------------------------------------------------|
| DESCRIPTION | | | |
| Total thickness | EN ISO 24346 (EN 428) | mm | 6 |
| Wearlayer thickness | EN ISO 24340 (EN 429) | mm | 2 |
| Weight | EN ISO 23997 (EN 430) | g/m ² | 9240 |
| Size | EN ISO 24342 (EN 427) | mm | 635 x 635 (GTI EL5 CONNECT) 650 x 650 (GTI EL5 CLEANTECH) |
| CLASSIFICATION | | | |
| Norm / Product specification | - | - | EN ISO 10582 (EN 649) |
| European classification | EN ISO 10874 (EN 685) | class | 34-43 |
| Fire rating | EN 13501-1 | class | Bfl-s1 |
| Electrical resistance ⁽¹⁾ | EN 1081 IEC 61340-4-1 IEC 61340-4-5 ANSI/ESD STM 7.1 | W | $5 \times 10^4 \leq R_t \leq 10^6$ $\leq 10^9$ $\leq 10^9$ $\leq 10^9$ |
| Static electrical propensity | EN 1815 IEC 61340-4-5 | kV V | < 2 $\leq 100^{(2)}$ |
| Protection against electrostatic discharges | ESD S20.20 IEC 61340-5-1 | - - | OK OK |
| Slip resistance wet: ramp test with oil | DIN 51 130 | class | R9 |
| PERFORMANCES | | | |
| Wear resistance | EN 660.2 | mm ³ | ≤ 4.0 |
| Wear group | EN 649 | group | P |
| Type Binder content | EN ISO 10582 | type | I |
| Dimensional stability | EN ISO 23999 (EN 434) | % | ≤ 0.25 |
| Castor chair test (type W) | ISO 4918 (EN 425) | - | OK |
| Shore Hardness | EN ISO 868 | H _D | ≥ 90 |
| Thermal conductivity | EN ISO 10456 (EN 12 524) | W/(m.k) | 0.25 |
| Colour fastness | EN 20 105 - B02 | degree | ≥ 6 |
| Surface treatment | - | - | Evercare™ |
| Chemical products resistance | EN ISO 26987 (EN 423) | - | OK |
| ENVIRONMENT / INDOOR AIR QUALITY | | | |
| TVOC after 28 days | ISO 16000-6 | µg/m ³ | <10 |
| Certification | - | - | Floorscore® |
| CE MARKING | | | |
| CE | EN 14041 | | |
| | | | |

(1) Measured before installation

(2) Measured with ESD shoes (type ABEBA and Uvex)

SPECIALITY FLOORING

SAFETY FLOORING - TARASAFE

▶ TARASAFE GEO: SPARCLEAN® TREATED

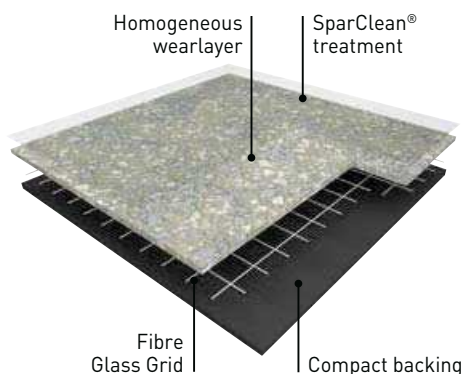

TARASAFE GEO is a slip resistant vinyl floorcovering, with a PVC wear layer and deeply inlaid mineral crystal particles and coloured chips for a decorative design. It is an ideal solution for traffic applications where enhanced slip resistance and durability are required. **TARASAFE GEO** is suitable for most contract & commercial areas. It is eco-friendly, 100% recyclable, Floorscore® certified and does not contain any heavy metals or CMR 1&2, it is also 100% compliant with REACH.

The product emission rate of volatile organic compounds is $< 100 \mu\text{g}/\text{m}^3$ (TVOC after 28 days – ISO 16000 -6).

The **SparClean®** surface treatment improves the product performance in terms of stain and dirt resistance and designs last longer for extended durability.

▶ TARASAFE ULTRA / ULTRA COMFORT: SPARCLEAN® TREATED

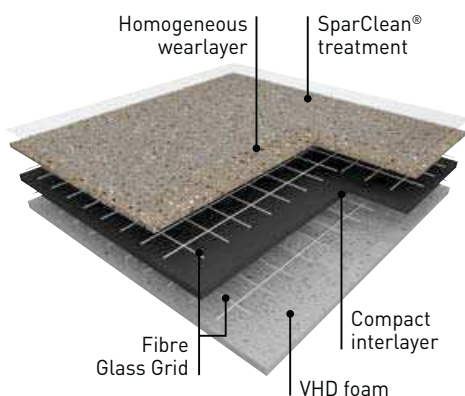

TARASAFE ULTRA & ULTRA COMFORT are slip resistant safety vinyl floorcoverings, with a PVC wear layer and deeply inlaid mineral crystal particles (patent pending) and coloured chips for a decorative design. They are reinforced with a glass fibre grid and are available in a sheet format. The ranges are ideal for heavy traffic applications where slip resistance, durability, hygiene and easy maintenance are required. Suitable for most contract & commercial areas, they are a popular choice in the education and healthcare environments, the matt finish surface is also perfectly suitable for dementia care units. They are eco-friendly, 100% recyclable, Floorscore® certified and do not contain any heavy metals or CMR 1&2. They are also 100% compliant with REACH. The product emission rate of volatile organic compounds is $< 100 \mu\text{g}/\text{m}^3$ (TVOC after 28 days – ISO 16000 -6). The **SparClean®** surface treatment improves the product performance in terms of stain and dirt resistance and designs last longer for extended durability.

TARASAFE ULTRA COMFORT has a VHD closed cell foam backing yielding a 16dB sound insulation.

▶ TARASAFE ULTRA H2O

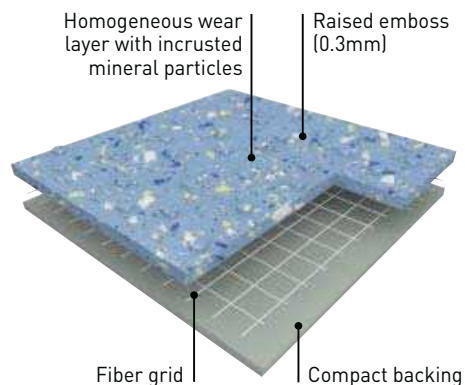

TARASAFE ULTRA H2O is a slip resistant vinyl floorcovering, with a PVC wear layer and deeply inlaid mineral particles and coloured chips for a decorative design together with a raised emboss for better slip resistance.

TARASAFE ULTRA H2O is an ideal solution for traffic applications where enhanced slip resistance with barefoot and durability are required such as wet areas. The specific embossing together with the mineral particles gives a Class C barefoot slip resistance (DIN 51 097) and R11 slip resistance (DIN 51 130) which makes **TARASAFE ULTRA H2O** ideal for barefoot or shod applications. It is reinforced with a glass fibre grid in sheet form. Its homogeneous wear layer provides a group P of abrasion. It does not contain any heavy metals or CMR 1&2 and it is 100% compliant with REACH. The product emission rate of volatile organic compounds is $< 100 \mu\text{g}/\text{m}^3$ (TVOC after 28 days – ISO 16000 -6). This product is 100% recyclable and contains 13% of recycled products.

TARASAFE

▶ TARASAFE STANDARD: PUR® TREATED

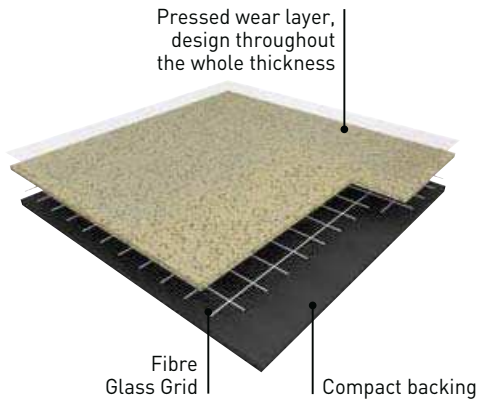

TARASAFE STANDARD with **PUR** surface treatment is a slip resistant safety vinyl floorcovering, with a PVC wear layer and deeply inlaid mineral crystal particles (patent pending). It is reinforced by a glass fibre grid and available in a sheet format. It is an ideal solution for heavy traffic applications where slip resistance, durability, hygiene and easy maintenance are required.

TARASAFE STANDARD is suitable for most contract & commercial areas. It is eco-friendly, 100% recyclable, Floorscore® certified and does not contain any heavy metals or CMR 1&2, it is also 100% compliant with REACH.

The product emission rate of volatile organic compounds is $< 100 \mu\text{g}/\text{m}^3$ (TVOC after 28 days – ISO 16000 -6).

The **PUR** surface treatment improves the product performance in term of stain resistance and durability.

▶ TARASAFE PLUS / TARASAFE SUPER: NON-TREATED

TARASAFE SUPER

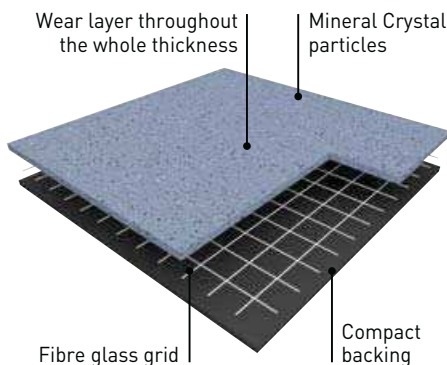

TARASAFE PLUS and **TARASAFE SUPER** are slip resistant safety vinyl floorcoverings, with a PVC wear layer and deeply inlaid mineral crystal particles (patent pending). They are reinforced with a glass fibre grid and available in a sheet format. They are an ideal solution for heavy traffic applications where slip resistance, durability, hygiene and easy maintenance are required.

TARASAFE PLUS comprises a textile backing for better adherence in wet areas. It helps reducing telegraphing.

TARASAFE SUPER and PLUS are suitable for most contract & commercial areas. They are eco-friendly, 100% recyclable, Floorscore® certified and do not contain any heavy metals or CMR 1&2, they are also 100% compliant with REACH.

The product emission rate of volatile organic compounds is $< 100 \mu\text{g}/\text{m}^3$ (TVOC after 28 days – ISO 16000 -6).

TARASAFE PLUS

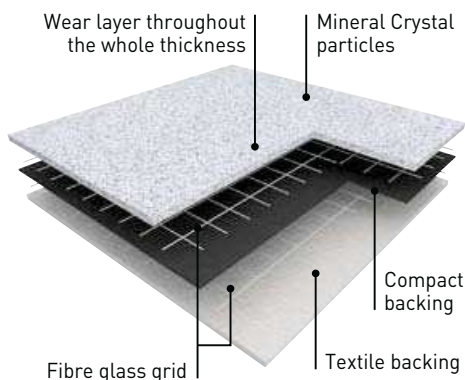

SPECIALITY FLOORING

TARASAFE



- ▶ **Easy to clean and maintain:** due to a compacted non porous surface made of vinyl content
- ▶ **Permanent slip resistance:** dense concentration of deep inlaid mineral crystal particles throughout the wear layer
- ▶ **Enhanced colour, design and brightness:** due to the mineral crystal particles
- ▶ **Highest abrasion rating**
- ▶ **Indoor Air Quality:** low VOC emission

TARASAFE ULTRA H₂O

- ▶ Complements the Tarasafe Ultra range
- ▶ Ideal solution for showers and changing rooms and high level risk wet areas.

| | TARASAFE | | | | | | | | |
|-----------------------------------------|-------------------------|---------------------|-----------------------|-----------------------|------------------------|-----------------------|-----------------------|-----------------------|--------|
| | GEO | ULTRA | STANDARD | ULTRA COMFORT | ULTRA H ₂ O | SUPER | PLUS | | |
| DESCRIPTION | | | | | | | | | |
| Total thickness | EN ISO 24346 (EN 428) | mm | 2.0 | 2.0 | 3.2 | 2.0 | 2.2 | 2.5 | |
| Thickness of wearlayer | EN ISO 24340 (EN 429) | mm | 1.00 | 0.85 | 0.85 | 0.85 | 1.00 | 1.12 | 1.14 |
| Weight | EN ISO 23997 (EN 430) | g/sq.m | 2370 | 2460 | 2460 | 2960 | 2400 | 2880 | 3090 |
| Width/Length of sheet | EN ISO 24341 (EN 426) | cm/ml | 200/20 | 200/20 | 200/20 | 200/20 | 200/20 | 200/20 | 200/20 |
| CLASSIFICATION | | | | | | | | | |
| Norm/Product specification | - | - | EN ISO 10582 (EN 649) | EN 651 | EN ISO 10582 (EN 649) | | | | |
| European classification | EN ISO 10874 (EN 685) | class | 34-43 | 34-43 | 34-42 | 34-43 | 34-43 | 34-43 | |
| Fire rating | EN 13501-1 | class | B _{fl} -s1 | B _{fl} -s1 | B _{fl} -s1 | C _{fl} -s1 | B _{fl} -s1 | B _{fl} -s1 | |
| Static electrical propensity | EN 1815 | kV | <2 | <2 | <2 | <2 | <2 | <2 | |
| SLIP RESISTANCE | | | | | | | | | |
| Pendulum Test (dry & wet) | BS 7976-2 | PTV (degree) | > 36 | > 36 | - | ≥ 36 | - | - | |
| Surface roughness | - | µm | Rz ≥ 20 | Rz ≥ 20 | - | Rz > 20 | - | - | |
| Ramp test with oil | DIN 51 130 | class | R10 | R10 | R10 | R11 | R12 | R10 | |
| Ramp test with water | DIN 51 097 | class | B | B | - | C | - | - | |
| Ramp test | EN 13845 (annex C) | class | ESf / ESb | ESf / ESb | - | ESb | - | - | |
| Slip resistance wet areas | CTE | class | - | - | - | 3 | - | - | |
| PERFORMANCES | | | | | | | | | |
| Wear resistance | EN 660.2 | mm ³ | ≤2 | ≤2 | ≤2 | ≤4 | ≤2 | ≤2 | |
| Wear group | NF 189 | - | T | T | T | P | T | T | |
| Type Binder content | EN ISO 10582 | type | I | I | - | I | I | I | |
| Dimensional stability | EN ISO 23999 (EN 434) | % | ≤0.40 | ≤0.40 | ≤0.40 | ≤0.40 | ≤0.40 | ≤0.40 | |
| Residual indentation: exigency | EN ISO 24343-1 (EN 433) | mm | ≤0.10 | ≤0.10 | ≤0.20 | ≤0.10 | ≤0.10 | ≤0.10 | |
| Residual indentation (average measure) | - | mm | ≈ 0.03 | ≈ 0.05 | ≈ 0.03 | ≈ 0.03 | ≈ 0.03 | ≈ 0.03 | |
| Castor chair test (type W) | ISO 4918 (EN 425) | - | OK | OK | OK | OK | OK | OK | |
| Impact sound Insulation | EN ISO 717-2 | dB | - | - | 16 | - | - | - | |
| Thermal conductivity | EN ISO 10456 (EN 12524) | W/(m.K) | 0.25 | 0.25 | 0.25 | 0.25 | 0.25 | 0.25 | |
| Colour fastness | EN 20 105-B02 | degree | ≥6 | ≥6 | ≥6 | ≥6 | ≥6 | ≥6 | |
| Surface treatment | - | - | SparClean® | PUR | SparClean® | - | - | - | |
| Chemical products resistance | EN ISO 26987 (EN 423) | - | OK | OK | OK | OK | OK | OK | |
| Anti-bacterial activity (MRSA) (1) | ISO 22196 | - | > 99% inhibits growth | > 99% inhibits growth | > 99% inhibits growth | > 99% inhibits growth | > 99% inhibits growth | > 99% inhibits growth | |
| ENVIRONMENT / INDOOR AIR QUALITY | | | | | | | | | |
| TVOC after 28 days | ISO 16000-6 | µg / m ³ | <100 | <100 | <100 | <100 | <100 | <100 | |
| Certification | - | - | Floorscore® | Floorscore® | Floorscore® | Floorscore® | Floorscore® | Floorscore® | |
| CE MARKING | | | | | | | | | |
| CE | EN 14041 | | | | | | | | |
| | | | | | | | | | |

(1) The implementation of an effective cleaning regime is the most important defence against infection.

TARASAFE GEO



2m

R 10

SparClean®



3775 Crystalline



3772 Cliff



3771 Rock



8081 Trail

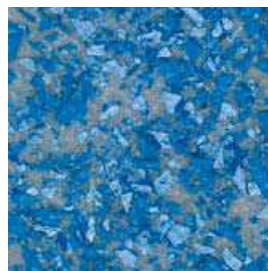

3409 Ocean Wave



3303 Desert

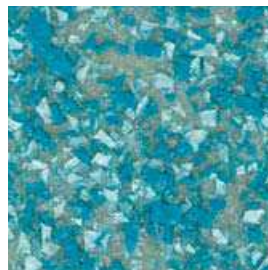

3405 Turquoise



3105 Sunspot

Specialty
Flooring



SPECIALITY FLOORING

TARASAFE ULTRA, TARASAFE ULTRA COMFORT

 2m |
  2m |
 R 10 |
 SparClean®

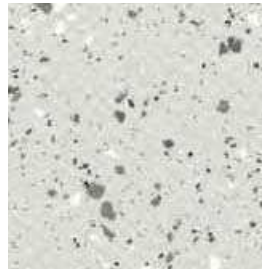

8701 Opal

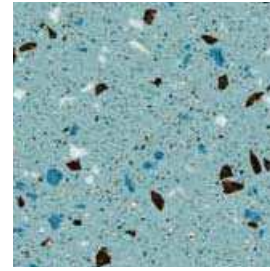

4463 Aqua

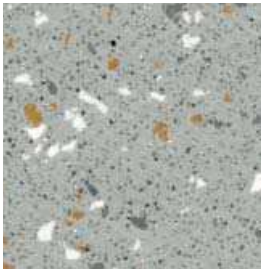

8704 Pebble

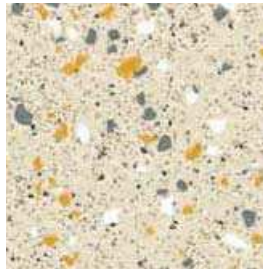

7383 Diopside

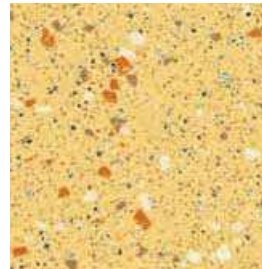

4323 Sandstone

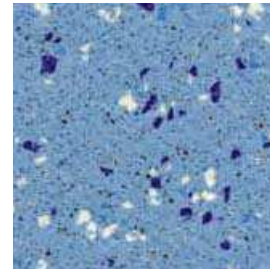

7482 Halite

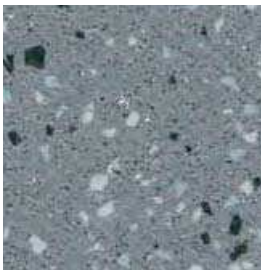

8709 Granite

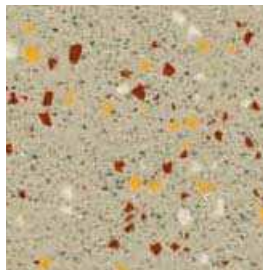

7384 Citrine

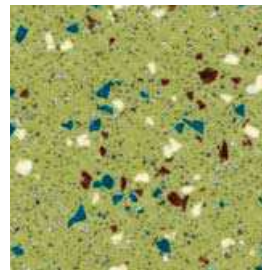

4505 Peridot

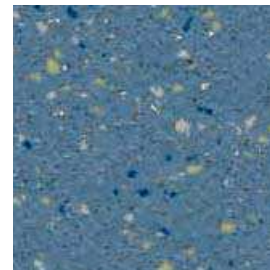

4465 Cobalt

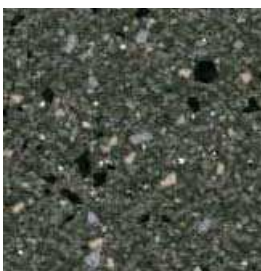

8710 Basalt

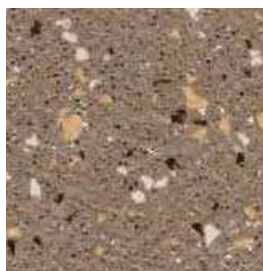

8013 Jasper

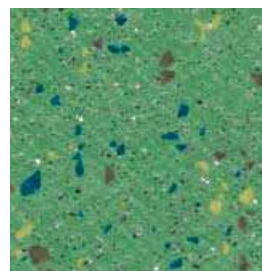

4508 Jade

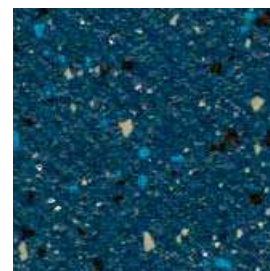

4472 Moonstone



8717 Obsidian

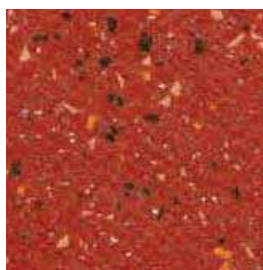

4128 Ruby

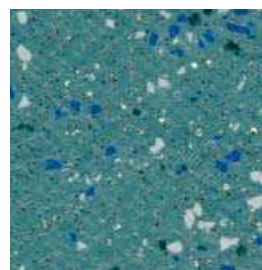

4460 Topaz

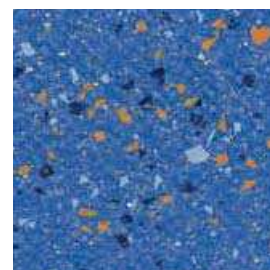

4470 Sapphire

Speciality Flooring

SPECIALITY FLOORING

TARASAFE ULTRA H2O

Compact 2m R 11



7325 Seashore

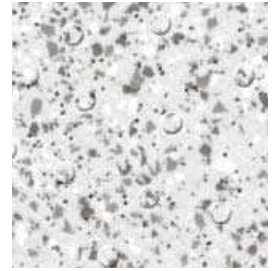

7720 Iceberg

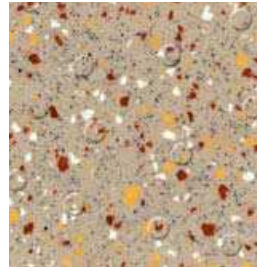

7314 Sand

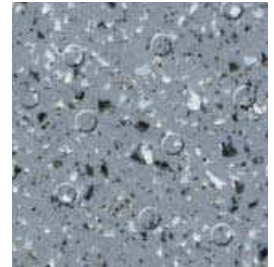

7746 Stone

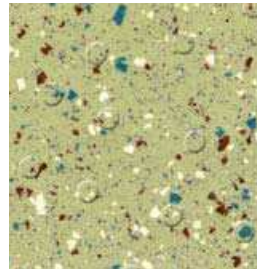

7513 Seagrass

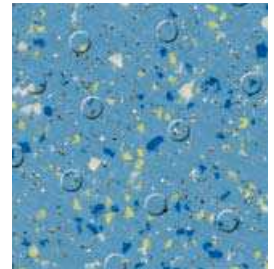

7418 Marine

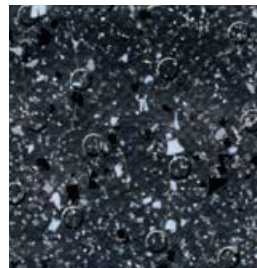

7732 Gravel

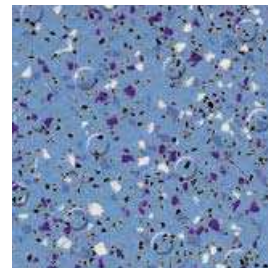

7413 Ocean Blue



Suitable for both barefoot and shod use

TARASAFE STANDARD - PLUS - SUPER

| | | | | |
|-------------------|----------------------------------------------------------------------------------------------------------------------------|----|------|-----|
| TARASAFE STANDARD |  Compact | 2m | R 10 | PUR |
| TARASAFE PLUS |  Plus 2.5mm Compact Textile backing | 2m | R 10 | |
| TARASAFE SUPER |  Compact | 2m | R 12 | |



7731 Marbre⁽¹⁾



7618 Edelweiss

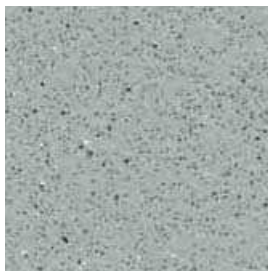

7767 Dove Grey^{(1) (2)}

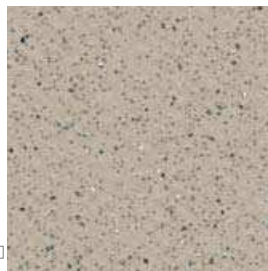

7386 Savana^{(1) (2)}



7312 Dune

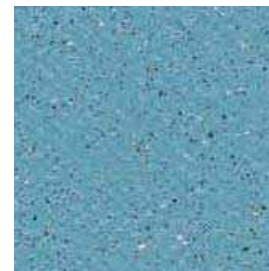

7704 Sky Blue



7773 Storm



7302 Sahara⁽¹⁾

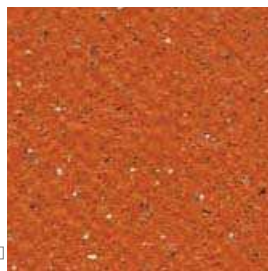

7115 Flame

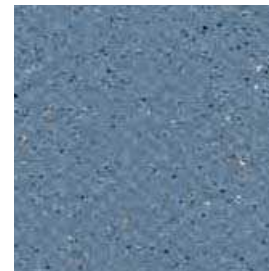

7438 Baleine^{(1) (2)}



7801 Noir



7508 Avocado



7107 Poppy



7709 Royal Blue

(1) Tarasafe Plus - (2) Tarasafe Super

Specialty
Flooring

SPECIALITY FLOORING

TARADOUCHE SHOWER SYSTEM

ELEGANCE SD

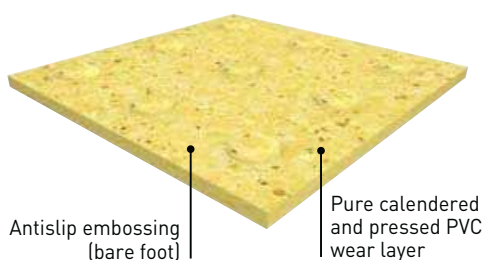

SHOWER SYSTEM ELEGANCE SD is a flexible homogeneous calendered compacted floorcovering available in 2 m sheet, with a non directional polychrome design, to offer an even colour throughout the thickness. It should be hot welded with a CR 40 welding rod.

SHOWER SYSTEM ELEGANCE SD is specifically embossed for wet barefoot traffic and has a group P wear rating.

ELEGANCE SD is compliant with antislip resistance norms (R9 according to DIN 51130 and A classification according to DIN 51097) for a **safe usage** in barefoot or shod applications such as showers. The Taradouche System enables access for all in showers especially for disabled people.

It is made of 32% mineral material and 34% renewable material. It uses 100% controlled recycled material. The TVOC emissions in the air at 28 days (EN 16000) are $< 10 \mu\text{g} / \text{m}^3$. It is 100% recyclable.

TARASAFE ULTRA H2O

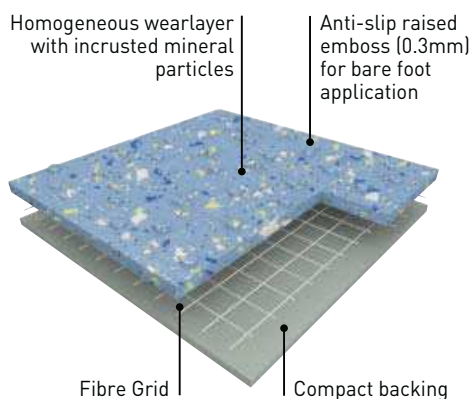

TARASAFE ULTRA H2O is a slip resistant vinyl floorcovering, with a PVC wear layer and deeply inlaid mineral particles and coloured chips for a decorative design together with a raised emboss for better slip resistance.

TARASAFE ULTRA H2O is an ideal solution for traffic applications where enhanced slip resistance with barefoot and durability are required such as wet areas. The specific embossing together with the mineral particles gives a Class C barefoot slip resistance (DIN 51 097) and R11 slip resistance (DIN 51 130) which makes **TARASAFE ULTRA H2O** ideal for barefoot or shod applications.

It is reinforced with a glass fibre grid in sheet form. Its homogeneous wear layer provides a group P of abrasion.

It does not contain any heavy metals or CMR 1&2 and it is 100% compliant with REACH. The product emission rate of volatile organic compounds is $< 100 \mu\text{g}/\text{m}^3$ (TVOC after 28 days – ISO 16000 -6). This product is 100% recyclable and contains 18% of mineral material and 22% of inexhaustible material.

MURAL CALYPSO

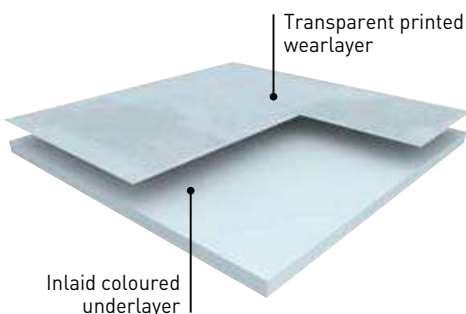

MURAL CALYPSO is a multilayered wall covering in 2m width roll and with a **B-s2,d0 fire classification** according to EN 13501.

It is hot welded with CR41 welding rods for a perfect water tightness.

It is made of a printed transparent wear layer and a coloured under layer for a better aspect of the welding. This layer comprises 20% of recycled products. It does not contain any CMR 1 & 2 component and is 100% compliant with REACH.

It is 100% recyclable.

This wall covering is specially recommended for wet room areas and makes the installation in angles easier thanks to its flexibility.

The Shower System is compliant with most laws on “access for all” thanks to the installation in shower without tray.

Gerflor also recommends the Tarasafe compact ranges with surface treatments (SparClean®: Geo & Ultra / PUR: Standard) for the use in wet room areas.

See pages 218-225

ELEGANCE SD / TARASAFE ULTRA H2O / MURAL CALYPSO



The TARADOUCHE SHOWER SYSTEM provides a safe and hygienic solution thanks to:

- ▶ Anti-slip resistance floorings
- ▶ 100% waterproof installation

| | | | ELEGANCE SD | TARASAFE ULTRA H2O | MURAL CALYPSO | |
|---------------------------------------------------------------------|--------------------------|---------------------|-----------------------|-----------------------|-----------------------|---|
| DESCRIPTION | | | | | | |
| Total thickness | EN ISO 24346 (EN 428) | mm | 2.4 (on grainside) | 2.0 (on grainside) | 0.92 | |
| Thickness of wearlayer | EN ISO 24340 (EN 429) | mm | 2.40 | 1.0 | 0.10 | |
| Weight | EN ISO 23997 (EN 430) | g/sq.m | 3100 | 2400 | 1610 | |
| Width/Length of sheet | EN ISO 24341 (EN 426) | cm/ml | 200/20 | 200/20 | 200/30 | |
| CLASSIFICATION | | | | | | |
| Product specification | - | - | EN ISO 10581 (EN 649) | EN ISO 10582 (EN 649) | EN 15 102 | |
| European classification | EN ISO 10874 (EN 685) | class | 34-43 | 34-43 | - | |
| Fire rating | EN 13501-1 | class | Bfl-s1 | Cfl-s1 | B-s2,d0 | |
| Static electrical propensity | EN 1815 | kV | < 2 | < 2 | - | |
| Slip resistance wet : ramp test with oil | DIN 51130 | class | R9 | R11 | - | |
| Slip resistance wet: bare foot | DIN 51 097 | class | A | C | - | |
| Determination of slip resistance barefoot & shod + water | EN 13845-annexe C | class | - | ESb | - | |
| Water tightness | EN 13553 | - | OK | In progress | - | |
| PERFORMANCES | | | | | | |
| Wear resistance | EN 660.2 | mm ³ | ≤ 4.0 | ≤ 4.0 | - | |
| Wear group | NF 189 | group | P | P | - | |
| Type Binder content | ISO 10581 | type | I | - | - | |
| Type Binder content | ISO 10582 | type | - | I | - | |
| Dimensional stability | EN ISO 23999 (EN 434) | % | ≤ 0.40 | ≤ 0.40 | - | |
| Residual indentation | EN ISO 24343-1 (EN 433) | mm | ≤ 0.10 | ≤ 0.10 | - | |
| Residual indentation (measure) | - | mm | ≈ 0.03 | ≈ 0.03 | - | |
| Thermal conductivity | EN ISO 10456 (EN 12 524) | W/(m.k) | 0.25 | 0.25 | - | |
| Colour fastness | EN 20 105 - B02 | degree | ≥ 6 | ≥ 6 | ≥ 6 | |
| Chemical products resistance | EN ISO 26987 (EN 423) | - | OK | OK | OK | |
| Anti-bacterial activity (E. coli - S. aureus - MRSA) ⁽¹⁾ | ISO 22196 | - | - | > 99% inhibits growth | > 99% inhibits growth | |
| ENVIRONMENT / INDOOR AIR QUALITY | | | | | | |
| TVOC after 28 days | ISO 16000-6 | µg / m ³ | <10 | <100 | - | |
| Certification | - | - | Floorscore® | Floorscore® | - | |
| CE MARKING | | | | | | |
| CE | EN 15102 | | - | | OK | |
| | EN 14041 | | | | | - |
| | | | | | | - |

(1) The implementation of an effective cleaning regime is the most important defence against infection.

SPECIALITY FLOORING

ANTISLIP FLOORING

ELEGANCE SD



100% recyclable



0341 Bilberry



0338 Kiwi



0333 Ananas



0700 Melon



0704 Raspberry grey



0705 Patisson



0322 Jicama



0329 Hazelnut

TARASAFE ULTRA H2O



100% recyclable

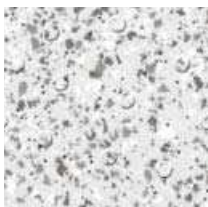

7720 Iceberg



7746 Stone

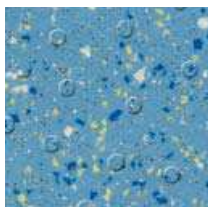

7418 Marine

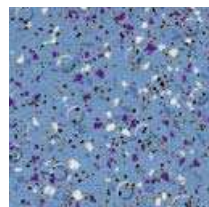

7413 Ocean Blue

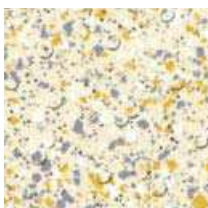

7325 Seashore

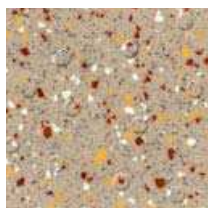

7314 Sand

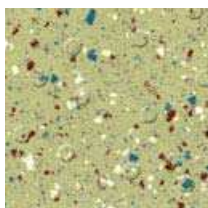

7513 Seagrass



7732 Gravel



MURAL CALYPSO



Bs2d0



100% recyclable



7110 Fushia

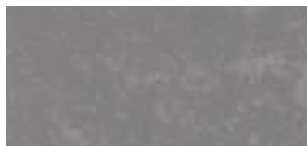

7751 Steel



7744 Nordic Milk

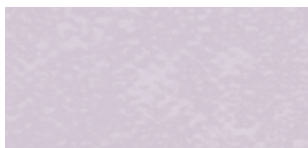

7112 Lilac

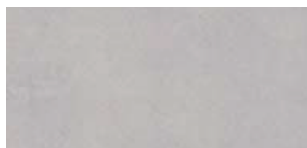

7714 Frost



7753 Nordic Zen



7408 Skyline

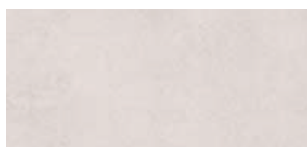

7715 Crystal

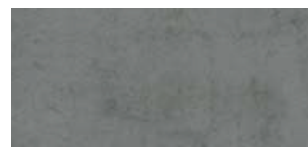

7734 Manhattan Concrete



7412 Glow

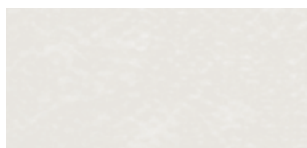

7711 Ice

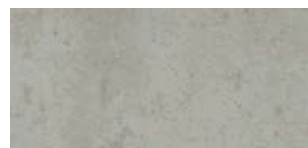

7728 Manhattan Stone



7420 Lagoon

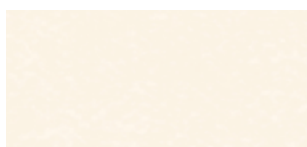

7611 Snow

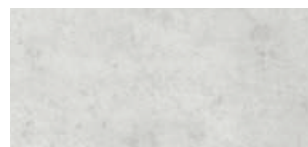

7721 Manhattan Mist



7505 Anise



7309 Lotus



7740 Fabric Silk

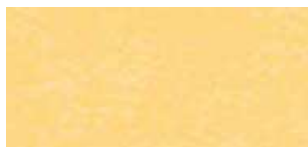

7201 Moonlight



7712 Shadow



7736 Fabric Wool



7104 Melon



7311 Linen



7315 Fabric Jute



7323 Ochre

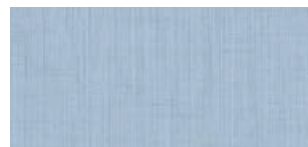

7414 Fabric Denim



SPECIALITY FLOORING

TARADOUCHE SHOWER SYSTEM

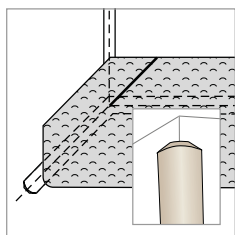

Cove former for internal wall angles CA 12 - H204

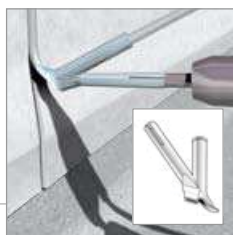

Perfect wall weld with CR41- H231

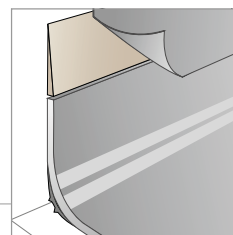

Diminishing profile - 0490

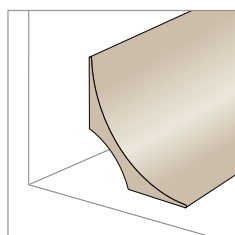

Cove former - 4011

PVC drain with inox grid H090



Tarafoam: acoustic insulation sub-layer 997C 6792

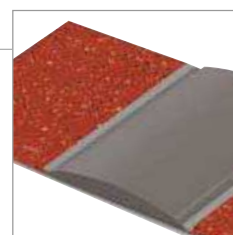

Shower threshold - 0469



PVC SITAR / SITAR V Drains H112 / H113

The threshold has been developed in 3 colours - grey, beige and blue in order to answer to the specific requirement of Alzheimer units (no contrast).

grey ●
beige ○
blue ●

Accessories: Drains, floor/wall diminishing strip, cove former, weldable Vinyl shower threshold, CA12 angle cove former.

Installation: Installation should be carried out in accordance with local standards. Subfloor to be flat, smooth hard, clean and dry prior to laying. Where applicable the subfloor must incorporate an effective Damp Proof Membrane. The material must be allowed to acclimatise for 24 hours prior to installation at a room temperature of between 18-24°C. All seems must be heat welded using Gerflor matching weld rod.

Maintenance: No emulsion dressings or polish required. Maintenance should be carried out regularly to retain the appearance and durability of the floor. The floorcovering should be maintained with regular sweeping and damp mopping using a neutral cleanser.

Further installation and maintenance instructions are available from Gerflor.

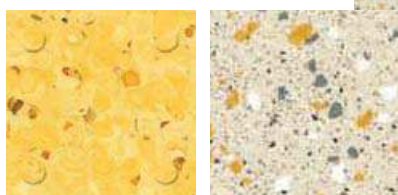
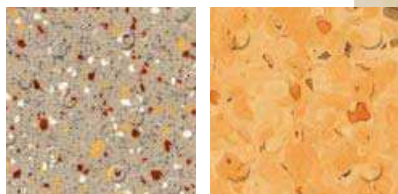
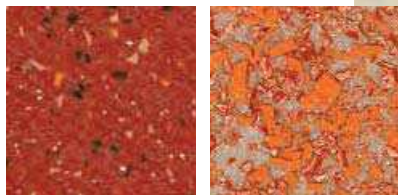
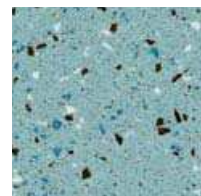
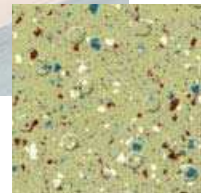

SPECIALITY FLOORING

WALLCOVERING - MURAL ULTRA / MURAL CLUB / MURAL CALYPSO

MURAL ULTRA

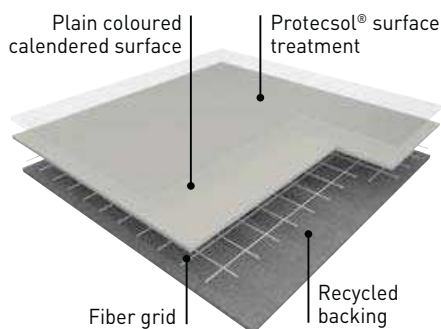

MURAL ULTRA is a flexible wall covering vinyl sheet which has a thickness of 1.5mm for an extended durability. It has a B-s2,d0 fire classification (EN 13501-1) which complies with most European fire regulations. It is made of a pure PVC coloured surface and a backing which comprises 25% of recycled products. This multi-layered product is reinforced with a non-woven glassfibre grid for improved resistance to tearing and excellent dimensional stability. It has a great resistance to chemical products staining thanks to its **ProtecSol®** surface treatment. The joints are hot-welded to ensure perfect water-tightness. It is 100 % recyclable and the components are 100% compliant with REACH.

MURAL CLUB

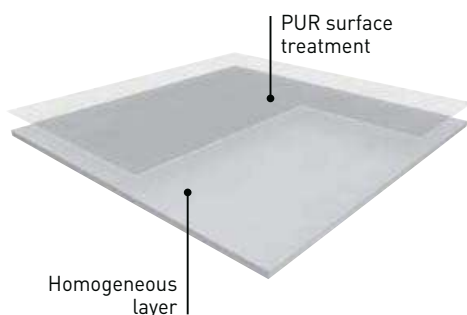

MURAL CLUB is a homogeneous wall covering in 2m width roll and with a B-s2,d0 fire classification. It is designed to be a permanent wall covering. It is hot welded with CR40 welding rods for better hygiene. It is made of calendared layer with colour throughout the whole thickness for a nicer aspect of the welding. This layer comprises at least 10% of recycled products. It does not contain any CMR 1 & 2 component and is 100% compliant with REACH. It is 100% recyclable.

MURAL CLUB benefits from a **PUR** surface treatment which provides good resistance to chemical products and makes maintenance easier. Full resistant to impact, it acts as a buffer against damage from beds, trolleys and indoor motorized vehicles and other transportation systems. **MURAL CLUB** is fully impact resistant and is therefore ideal for use as a cladding in large public buildings such as hospitals care institutions dental and veterinary surgeries, clean rooms, stores and supermarkets, warehouse and storage areas.

MURAL CALYPSO

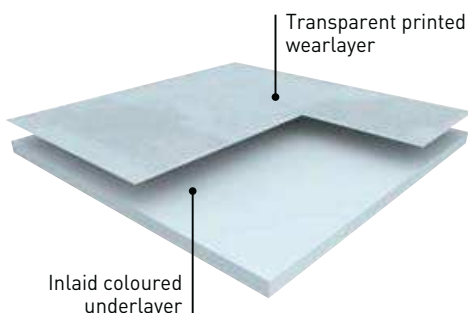

MURAL CALYPSO is a multilayered wall covering in 2m width roll and with a **B-s2,d0 fire classification** according to EN 13501. It is hot welded with CR41 welding rods for a perfect water tightness. It is made of a printed transparent wear layer and a coloured under layer for a better aspect of the welding. This layer comprises 20% of recycled products. It does not contain any CMR 1 & 2 component and is 100% compliant with REACH. It is 100% recyclable.

This wall covering is specially recommended for wet room areas and makes the installation in angles easier thanks to its flexibility.

The Shower System is compliant with most laws on "access for all" thanks to the installation in shower without tray.

WALLCOVERING - MURAL ULTRA / MURAL CLUB / MURAL CALYPSO

- ▶ Easily seam welded to produce continuous surfaces.
- ▶ Create a safe and hygienic environment.
- ▶ Flexible and easy to cove.
- ▶ Ideal for walls and ceilings.
- ▶ Recyclable and Eco responsible.

| | | | MURAL ULTRA | MURAL CLUB | MURAL CALYPSO |
|-------------------------------------------------------------------------------------|-----------------------|--------|--------------------------|--------------------------|--------------------------|
| DESCRIPTION | | | | | |
| Total thickness | EN ISO 24346 (EN 428) | mm | 1.5 | 1.00 | 0.92 |
| Thickness of wearlayer | EN ISO 24340 (EN 429) | mm | 0.65 | 1.00 | 0.10 |
| Weight | EN ISO 23997 (EN 430) | g/sq.m | 2600 | 1780 | 1610 |
| Width/Length of sheet | EN ISO 24341 (EN 426) | cm/ml | 200 / 21 | 200 / 30 | 200/30 |
| CLASSIFICATION | | | | | |
| Product specification | - | - | EN 15 102 | EN 15 102 | EN 15 102 |
| Fire rating | EN 13501-1 | class | B-s2,d0 | B-s2,d0 | B-s2,d0 |
| PERFORMANCES | | | | | |
| Colour fastness | EN 20 105 - B02 | degree | ≥ 6 | ≥ 6 | ≥ 6 |
| Surface treatment | - | - | Protecsol® | PUR | - |
| Chemical products resistance | EN ISO 26987 (EN 423) | - | OK | OK | OK |
| Anti-bacterial activity (E. coli - S. aureus - MRSA) ⁽¹⁾ | ISO 22196 | - | > 99% inhibits growth | > 99% inhibits growth | > 99% inhibits growth |
| CE MARKING | | | | | |
|  | EN 15102 | | OK | | |

(1) The implementation of an effective cleaning regime is the most important defence against infection.



SPECIALITY FLOORING

MURAL ULTRA / MURAL CLUB

MURAL ULTRA



Protectsol®



100% recyclable

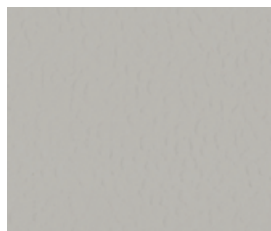

3765 Flannel

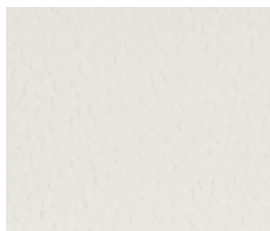

3735 Arctic

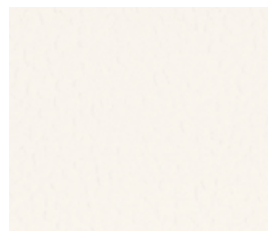

8608 Lily

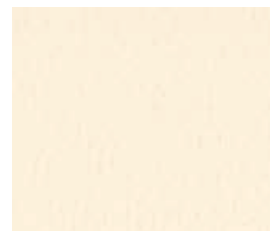

4345 Ecrú

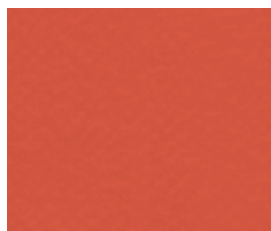

4150 Cranberry



4116 Apricot



4346 Sand



8253 Lemon

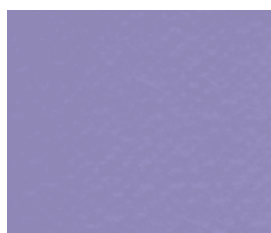

4118 Violet

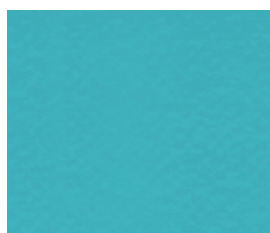

4494 Pacific



4497 Lobelia



4525 Lime

MURAL CLUB



PUR



100% recyclable



0001 White



0003 Sand



0006 Grey



0005 Yellow



0004 Green



0007 Blue

MURAL CALYPSO



Bs2d0



100% recyclable



7110 Fushia



7751 Steel



7744 Nordic Milk

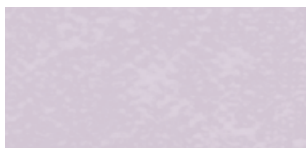

7112 Lilac

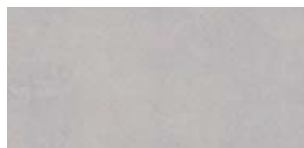

7714 Frost



7753 Nordic Zen



7408 Skyline

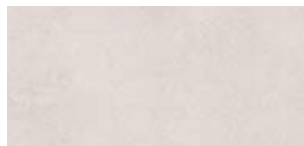

7715 Crystal

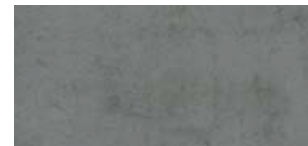

7734 Manhattan Concrete



7412 Glow

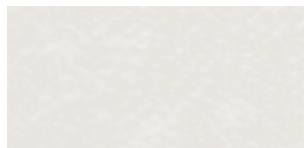

7711 Ice

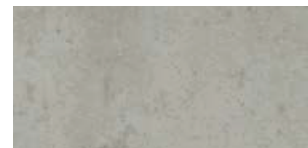

7728 Manhattan Stone



7420 Lagoon

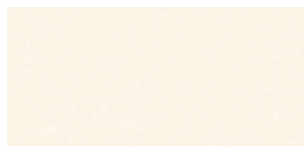

7611 Snow

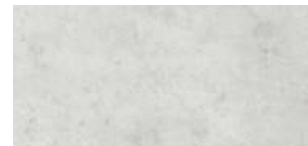

7721 Manhattan Mist



7505 Anise



7309 Lotus



7740 Fabric Silk

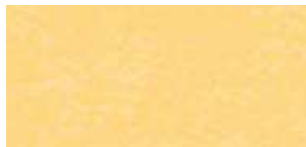

7201 Moonlight



7712 Shadow



7736 Fabric Wool



7104 Melon



7311 Linen



7315 Fabric Jute



7323 Ochre

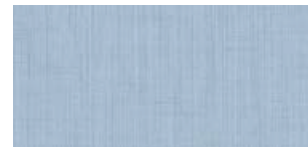

7414 Fabric Denim





SPORTS
FLOORING

PAGES

236 / 269



Taraflex™ Sports Flooring242-259

**Hardwood flooring
systems Connor Sports®260-265**

**Outdoor play areas
Sport Court266-269**

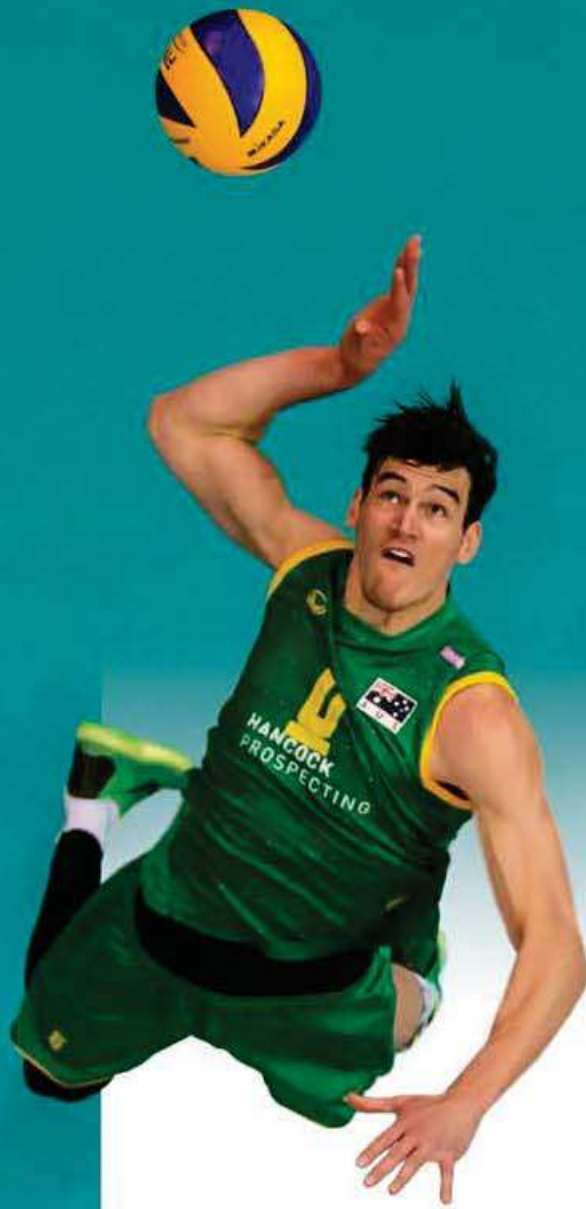

Gerflor®

Where Champions Play™

TARAFLEX
SPORTS

C
CONNOR
SPORTS

EG
SPORT
COURT

GERFLOR YOUR UNIQUE PROVIDER FOR INDOOR AND OUTDOOR SPORTS INSTALLATIONS

GERFLOR HAS REVOLUTIONISED INDOOR SPORTS PRACTICES & KEEPS ON INNOVATING!

TARAFLEX®
SPORTS

INDOOR SYNTHETIC FLOOR
THE BEST PERFORMING
PRODUCT ON THE MARKET



Taraflex™ has been around since 1947 when synthetic sports floors were first invented.

Protection and safety are the main concerns when we are developing a new floor. With a complete range of P1/P2/P3 products, Gerflor offers the perfect solution adapted to all users and usages, from low impact activities through elite and performance sports. Gerflor is committed to ongoing sustainability; incorporated into its floor performance and properties.

PAGES 242 - 259

**CONNOR
SPORTS**

HARDWOOD FLOORING
SYSTEMS
MORE THAN 100 YEARS
OF EXPERIENCE



Founded in 1872, Connor Sports® is the market leader in portable and permanent hardwood sports flooring systems.

Connor Sports® professional engineers have lead the industry in new product design and development, setting the standard for innovative solutions in sports surfacing.

In 1914, Connor Sports® installed the first basketball court in the USA.

In the late 90's, Boston Celtics selected Connor Sports® to repurpose their famed parquet into a portable flooring system.

PAGES 260 - 265

**SPORT
COURT**

OUTDOOR PLAY AREAS
WORLD'S LEADING
OUTDOOR SPORT
SURFACE



In 1974, Sport Court created the outdoor game court. Since then, over 150,000 courts have been installed worldwide.

Sport Court's superior outdoor play surface is designed to:

- keep athletes safe
- allow for year-round sports activity
- eliminate costly annual maintenance

PAGES 266 - 269

THE UNIQUE PROVIDER OF YOUR NEXT INTERNATIONAL EVENT

TARAFLEX
SPORTS

**LEADER
IN INDOOR SPORTS**

floorball, handball, volleyball, futsal,
table tennis, Badminton, Boccia, Goalball,
sitting volleyball

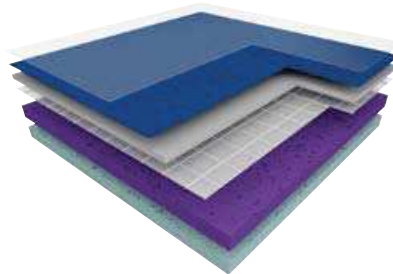

**TECHNICAL PARTNER
OF FIBA & NCAA**

NBA's preferred
hardwood flooring

Floating system
REZILLSLEEPER



Anchored system
ALLIANCE



**OFFICIAL 3X3
FIBA PARTNER**
Original outdoor event tiles
(FIVB Technical Partner)

POWERGAME™

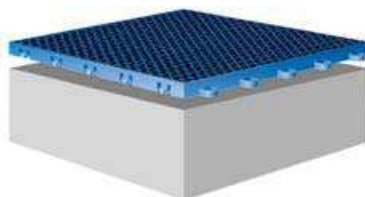

**THE MOST PREFERRED FLOOR PARTNER
OF INTERNATIONAL SPORT FEDERATIONS**



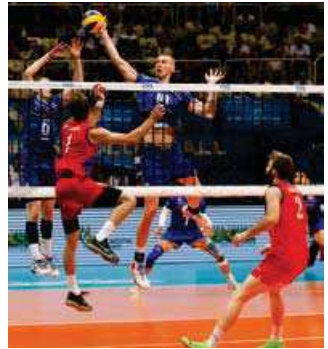

BWF
preferred supplier

Portable system
QUICKLOCK



Sports Flooring



PRODUCT SELECTION GUIDANCE

IPI

100%

PROTECTION...

...is a major mechanical property of the sports floor to provide the right level of **immediate comfort** to the users when falling, sliding or diving on the floor: less pains, less bruises, less bone traumatism.

IPI



IPI = IMPACT PROTECTION INDEX

| | |
|-----------------|-------------------|
| < 50% | low protection |
| 50% < IPI < 80% | medium protection |
| > 80% | high protection |

P2

PROTECTION Immediate comfort

80%

P1

2.1mm



TARAFLEX™
SURFACE
Protécsol

25%

6.2mm

IPI = 52%

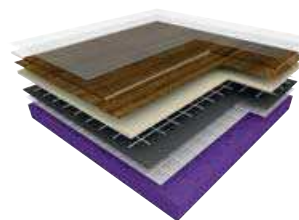

TARAFLEX™
MULTI-USE 6.2

Protécsol D-Max+ CXP HD

7mm

IPI = 73%

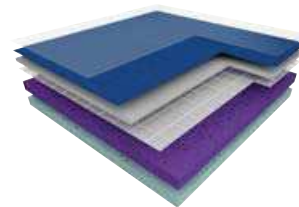

TARAFLEX™
SPORT M EVOLUTION

Dry-Tex™
SYSTEM
Protécsol D-Max CXP HD

35%

SAFETY Protection against long-term injuries

APPLICATIONS

- Toddlers (0-6 years old)
- Education
- Clubs / Competitions
- Adults / Seniors / Leisure
- Multipurpose

TARAFLEX™ MULTI-USE 6.2

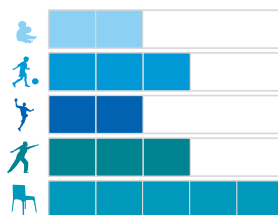

TARAFLEX™ SPORT M EVOLUTION

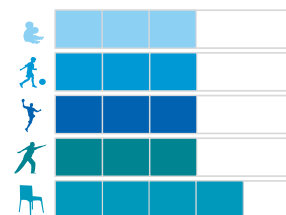

P3

12mm

IPI = 88%

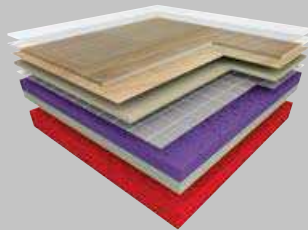

TARAFLEX™
SPORT M COMFORT

Protécsol D-Max CXPHD

9mm

IPI = 82%

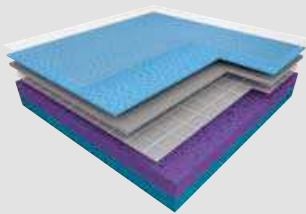

TARAFLEX™
SPORT M PERFORMANCE

Dry-Tex
SYSTEM

Protécsol D-Max CXPHD

SAFETY

Protection against **long term injuries** less shin splints, less tendonitis.

SA%



SA% = SHOCK ABSORPTION (EN 14904)

25% ≤ P1 < 35%

35% ≤ P2 < 45%

45% ≤ P3

45%

SA%

TARAFLEX™ SPORT M PERFORMANCE



TARAFLEX™ SPORT M COMFORT



TARAFLEX™ SPORTS FLOORING

242-259

- Why you should choose Taraflex™ 244
- The secrets of Taraflex™ sports flooring 246
- EN 14904 European Sports Flooring Standard 247
- Turn your design into reality 248
- Taraflex™ Multi-Use 6.2 250
- Taraflex™ Surface Mask 250
- 3D Court designer 251
- My Taraflex™ 251
- My Logos 251
- Performance Sports 252
- Product specification guidelines 254
- Technical solutions 255
- A full and technical range of accessories 256
- Technical data 258

FOR PROTECTION

The floor that brings **immediate protection on impact** to all users when falling, diving or sliding on the floor.

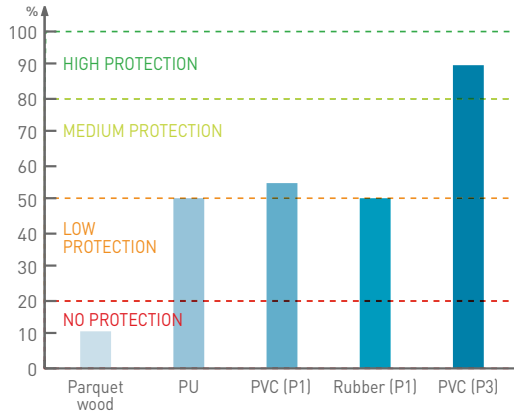

Gerflor offers Taraflex™ Sport M Comfort, a P3 floor with **the highest level of comfort on the market.**

FOR SAFETY

Shock absorption **minimizes the force** of impact on the body and reduces long term injury risk.

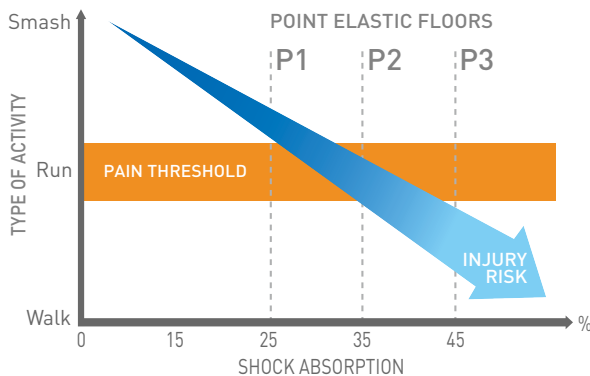

With a complete range of shock absorption **P1/P2/P3**, Gerflor provides the right solution and the best safety for users.

TARAFLEX™ SPORTS FLOORING IS RECOGNISED ALL OVER THE WORLD

3

FOR LIFE

Taraflex™ technology ensures a long lasting high performance of the products for the **LIFETIME OF THE FLOORS.**

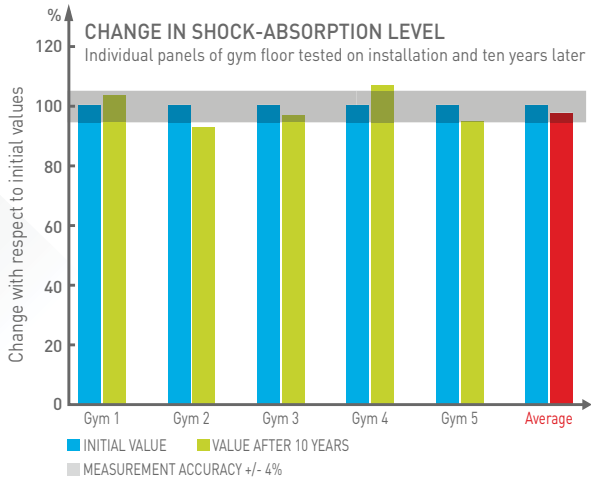

Study available on demand.



Gerflor guarantees the category P1/P2/P3 after 10 years use.

FLOORS FOR CHAMPIONS

PARTNER OF MAJOR SPORTS EVENTS



4

Gerflor, through IHF and FIVB agreements, has supplied courts for Handball and Volleyball tournaments during the last Olympic Games in Rio in 2016. Taraflex™ is the most widely specified sports surface in the world; it has been selected for 11 consecutive Olympic Games from Montreal to Rio 2016 for indoor surfaces like Handball, Volleyball, Badminton, Table Tennis and Sitting Volleyball.

Every day more than **6 million children** play on a Taraflex™ sports floor.

3500 high level competitions per year are played on Taraflex™ sports floor.

THE SECRETS OF TARAFLEX™ SPORTS FLOORING

1 ProtecSol^{TRIPLE ACTION}®

A **surface treatment** with the unique and patented triple action ProtecSol[®], offers three key benefits:

- ▶ An **'intelligent' surface treatment**, forming the ideal compromise between slide and grip for sports shoes. The floor provides safe grip and resistance as the athlete accelerates but allows the feet to move freely as they rotate.
- ▶ A **skin-burn free surface**, on which the temperature during a fall is reduced by 25%, thus minimising the risk of friction burns.
- ▶ A **surface that is cost effective and easy to maintain**.

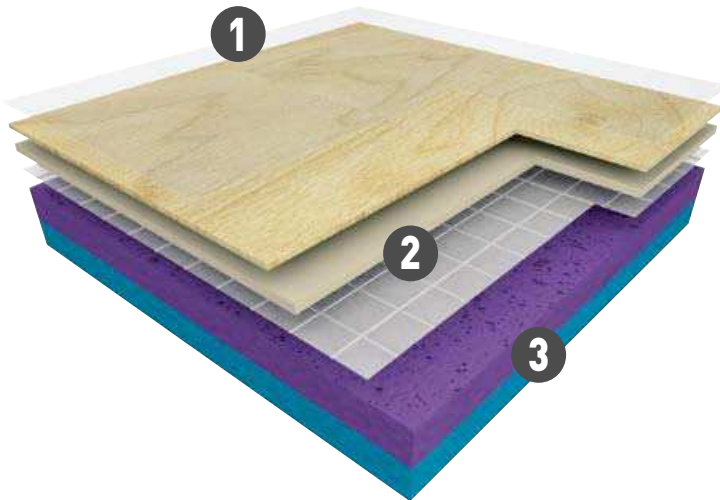

2 D-Max^{DURABILITY} / D-Max^{DURABILITY}+

D-Max™ surface is a **UNIQUE complex** made up of **calendered PVC sheets reinforced with fibreglass grids** ensuring high durability of Taraflex™ Sports Flooring.

D-Max™ +, an exclusivity Taraflex™, is reinforced with two fibreglass grids providing:

- ▶ **Outstanding dimensional stability** (>0.1%)
- ▶ **An indentation resistance** improved by 35% to increase the range of floor usages

D-Max^{DURABILITY}

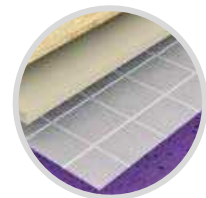

D-Max^{DURABILITY}+

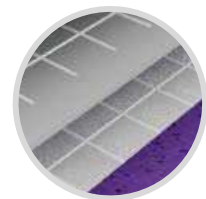

3 CXP^{COMFORT} HD

The **manufacturing process for CXP** (Cellular Xtreme Process) **closed-cell foams** has now been combined with the 'very high density' **VHD** foam technology developed by Gerflor.

Why use a double density foam?

At the moment of impact on the floor:

- ▶ The light and elastic foam of the lower layer compresses totally in order to ensure **protection and safety**.
- ▶ The VHD foam of the upper layer remains firm, making the deformation trough around the foot two times larger for more freedom of movement in rotation and secure foothold to minimise **the injury risk**.

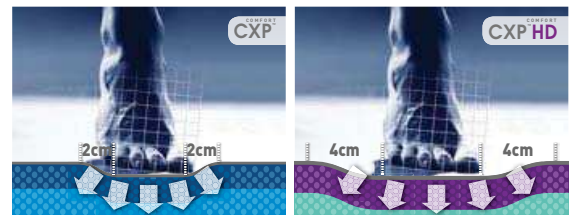

▶ The combination of ProtecSol[®], D-Max™/D-Max™+, CXP™HD foam ensures that Taraflex™ Sports Flooring are durable and high performing.

EN 14904 EUROPEAN SPORTS FLOORING STANDARD

EN 14904 Standard: minimal performance requirements to be met by indoor sports floors

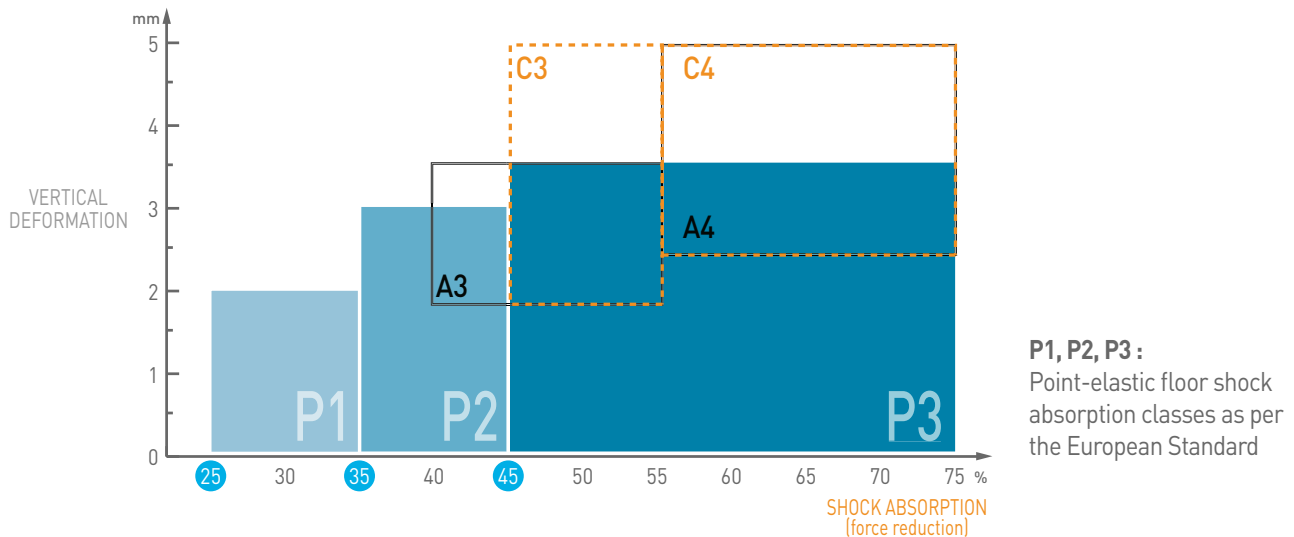

3 types of sports floors:

- 1 Point-elastic floors** such as Taraflex™ (Taraflex™ Sport M Evolution, Taraflex™ Sport M Performance, Taraflex™ Sport M Comfort and Taraflex™ Multi-Use 6.2).
- 2 Area-elastic floors** such as sprung wooden floors.
- 3 Combined floors**, providing a combination of point-elastic and area-elastic floor features.

Standard values:

The EN 14904 standard determines force reduction classes for all floors. The objective is to draw attention to the necessity of installing safe, comfortable floors that reduce the risk of injuries.

| EN 14904 | DESCRIPTION | STANDARD | REQUIREMENT | UNITS |
|---------------------------|------------------------------------|---------------|--------------------|-------|
| SPORTS PROPERTIES | Vertical deformation | EN 14809 | ≤ 3.5 | mm |
| | Shock absorption (Force Reduction) | EN 14808 | ≥ 25 | % |
| | Friction coefficient | EN 13036-4 | 80 - 110 | - |
| TECHNICAL CHARACTERISTICS | Ball bounce | EN 12 235 | ≥ 90 | % |
| | Indentation resistance | EN 1516 | ≤ 0.5 | mm |
| | Wheel resistance | EN 1569 | ≥ 1500 | N |
| | Impact resistance | EN 1517 | ≥ 8 | N/m |
| | Abrasion resistance | EN ISO 5470-1 | ≤ 1000 | mg |
| | Gloss | EN ISO 2813 | ≤ 30 | % |
| | Flatness | EN 13036-7 | < 6mm/3m | - |
| CLASSIFICATION | Fire rating | EN 13501-1 | C _{fl-s1} | - |
| | Formaldehyde emission | EN 717-1/2 | ≥ E1 | - |
| | Pentachlorophenol emission | EN 12673 | < 0.1 | % |

TURN YOUR DESIGN INTO REALITY



6350 - Light Cherry Design / Y = 43,3



6873 - Anthracite / Y = 20,5



6159 - Pink / Y = 19,1



6559 - Spring / Y = 47,1



6830 - Black / Y = 4,2

All colours are available with Taraflex™ Surface, Taraflex™ Sport M Evolution, Taraflex™ Sport M Performance and Taraflex™ Sport M Comfort



6347 - Beige / Y = 39,7



6570 - Mint Green / Y = 16,9



6557 - Forest / Y = 10,9



6375 - Oak Design / Y = 29,7

(Y): Light reflectance values according to the EN 13 745
Participates to lighting energy saving when Y > 20

Create and visualise your surface thanks to the 3D court designer
on gerflor.com

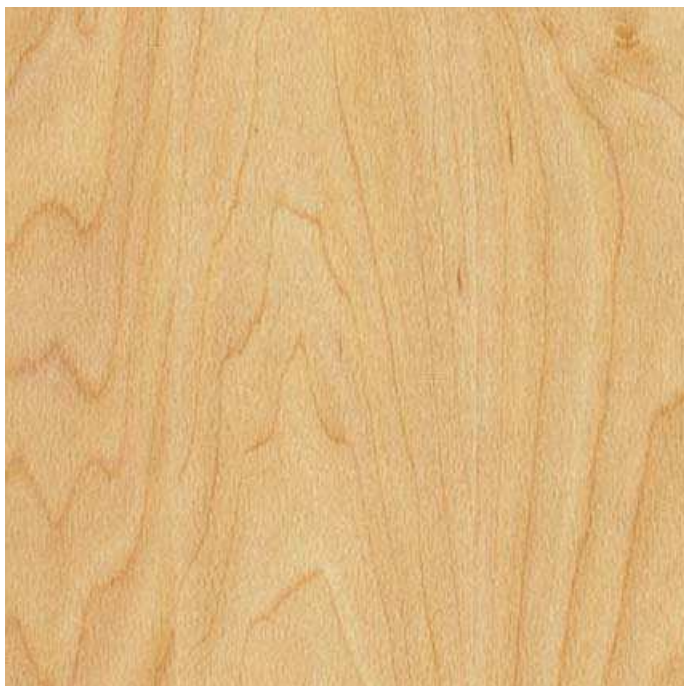

6381 - Maple Design / Y = 39,9



6180 - Red / Y = 10,9



6038 - Terracotta / Y = 19,9



6211 - Gold / Y = 45,7

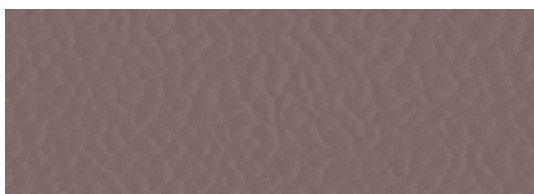

3764 - Taupe / Y = 17,9



6146 - Coral / Y = 28,7



6758 - Silver Gray / Y = 36



6431 - Teal / Y = 21,4



6445 - Lagoon / Y = 25,7



6430 - Blue / Y = 8,3



2404 - London Light Blue / Y = 33,8

TARAFLEX™ MULTI-USE 6.2



8068 - Wood Chocolate / Y = 9,4



4453 - Wood Blue / Y = 17,9



8840 - Wood Black / Y = 17,2

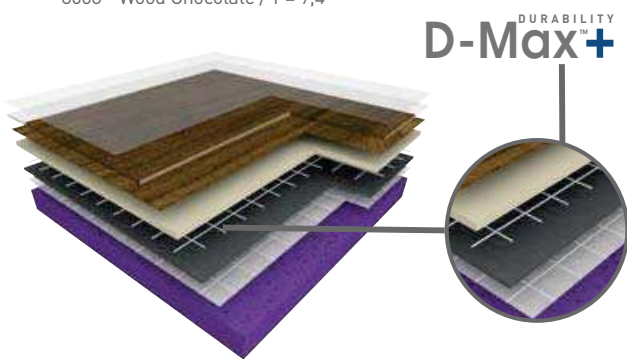

DURABILITY
D-Max+



4331 - Wood Natural / Y = 29,9



3708 - Wood Grey / Y = 34,2

TARAFLEX™ SURFACE MASK

Only available on a wood under-carriage system



6032 - München / Y = 55,4



6031 - Berlin / Y = 48,5



6009 - Frankfurt / Y = 52,4



6029 - Bonn / Y = 32,5



6035 - Dresden / Y = 33,1



6027 - Aachen / Y = 44,6



6055 - Freiburg / Y = 14,9



6046 - Celle / Y = 10,6

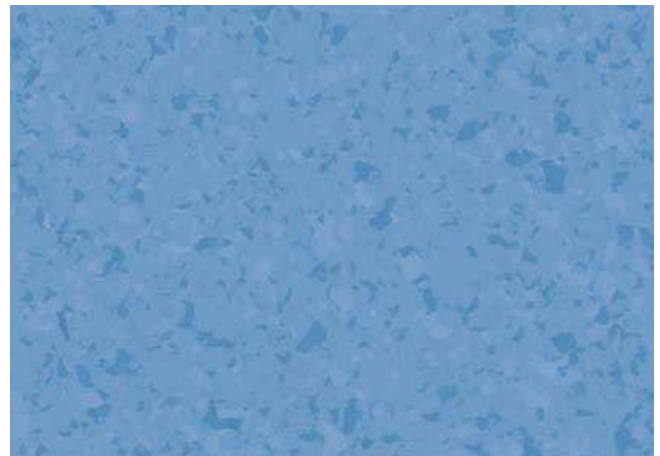

6016 - Hamburg / Y = 30,5

3D COURT DESIGNER TO VISUALISE YOUR PROJECT IN 3D



- 1 Choose your surface:
monosport or multisports



- 2 Choose your colours



- 3 Visualise
your surface in 3D

Also available on gerflor.com



MY TARAFLEX® FOR CUSTOMISED FLOORS

- 1 Choose your colours from 130 references

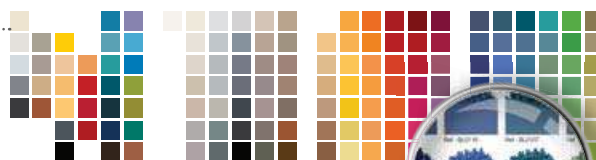

- 2 Receive your prototype free of charge within 15 working days of your request (excluding shipping time and maximum of 3 per completed form)

- 3 Validate



Condition: minimum order quantity 1000 sqm
per colour and per project



Visualise your harmonies on mytaraflex.gerflor.com

MY LOGOS FOR A STUNNING RESULT

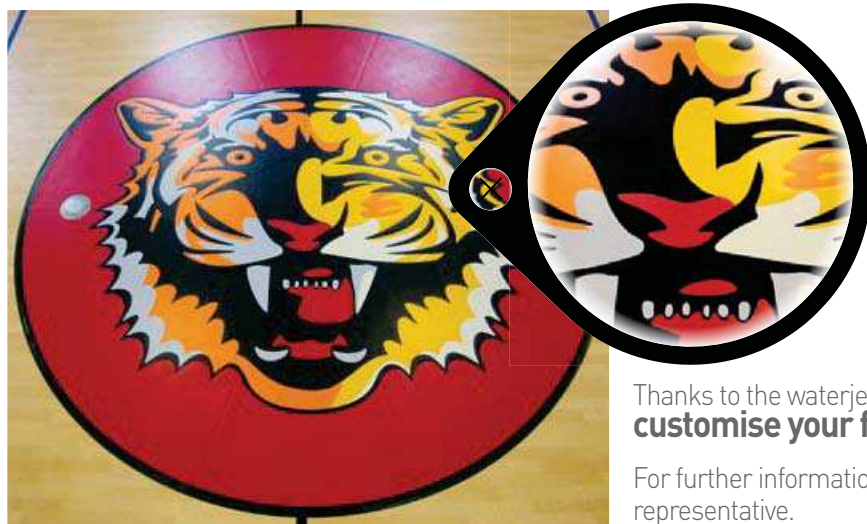

Thanks to the waterjet cutting technology,
customise your floor with your city or club colours.

For further information, please contact your sales representative.

PERFORMANCE SPORTS

BADMINTON

"The use of a Gerflor surface improves the quality of our training environment because it replicates the type of floors used at international competitions. The level of impact absorption achieved by Gerflor also helps to reduce foot traction problems and impact injuries, compared with a wooden floor."

Jens Grill - Performance Director, Badminton England - UK

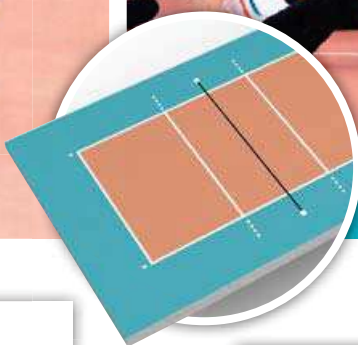
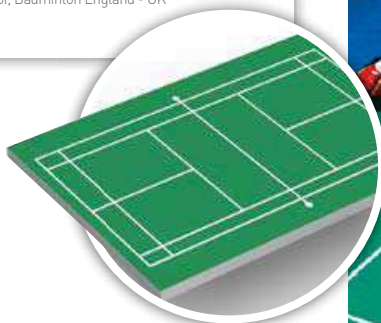

VOLLEYBALL

"The first time I played on Taraflex™ was at the Olympics. It's the best volleyball surface in the world. Every player and child deserves to play on Taraflex™."

Caren Kemner - Owner of Riverfront Athletic Club
Voted best female volleyball player in the world by the FIVB - USA



SITTING VOLLEYBALL

"The American team loved the Paralympic Floor. This is my third Paralympic Games so I've played on a lot of different types of flooring but this was by far my favorite. It was easy to move on which allowed for some really exciting play throughout the tournament! We wanted to roll it up and take it home with us."

Kendra Lancaster - USA Olympic Committee - USA





NETBALL / BASKETBALL

"The feed back so far from the players, coaches and referees regarding the surface has been very encouraging. It looks great on TV and we feel it will have a positive effect against injuries usually sustained playing on timber."

Mike Watson - Performance Competition Manager - UK



HANDBALL

"We've been partner with Gerflor since 2004, flooring is an essential part of our identity and is an indispensable asset for our sport."

Michael Wiederer - EHF Secretary General - AUSTRIA



EUROPEAN HANDBALL FEDERATION



TABLE TENNIS

"For me the floor has a crucial importance. The grip should be perfect balanced so the moves during the exchanges should be easy and comfortable."

Werner Schlager - Table Tennis World Champion - AUSTRIA



PRODUCT SPECIFICATION GUIDELINES

Choose your floor according to your usage

| | Basketball | Volleyball | Handball | Netball | Floorball | Futsal | Tennis | Table Tennis | Badminton | Multi-sports | Multi-purpose | Rolling Sports / Disability sports |
|------------------------------------------------------------------------------|-------------------------------------|------------|----------|---------|-----------|--------|--------|-------------------------------------|-----------|--------------|---------------|------------------------------------|
| TARAFLEX™ SPORT M COMFORT (P3) | | ■ | ■ | ■ | ■ | | | | | ■ | | |
| TARAFLEX™ SPORT M PERFORMANCE (P2) | ■ | ■ | ■ | ■ | ■ | ■ | | | | ■ | | |
| TARAFLEX™ SPORT M EVOLUTION (P1) | | ■ | | | | ■ | | ■ | ■ | ■ | | |
| TARAFLEX™ MULTI-USE 6.2 (P1) | | | | | | ■ | | | | | ■ | |
| TARAFLEX™ SURFACE | Installed over undercarriage system | | | | | | | Installed over undercarriage system | | | | ■ |
| TARAFLEX™ TENNIS (P1) | | | | | | | ■ | | | | | |
| TARAFLEX™ TABLE TENNIS 3.7 PORTABLE / 4.5 PERMANENT / 6.2 PERMANENT | | | | | | | | ■ | | | | |
| TARAFLEX™ BADMINTON 3.9 PORTABLE / 4.5 PERMANENT / 7 PERMANENT | | | | | | | | | ■ | | | |

■ = Recommended / ■ = Possible

TECHNICAL SOLUTIONS

► DRY-TEX™ SYSTEM: The all in one moisture solution

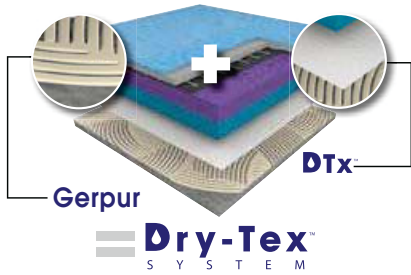

Textile backing

► TARAFLEX™ ISOLSPORT: Solution for renovation work and moisture barrier

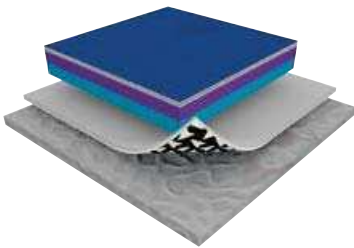

► TARAFLEX™ BATECO: Removable protective layer



✓ Made from 100% post manufacturing recycled waste



A FULL AND TECHNICAL RANGE OF ACCESSORIES

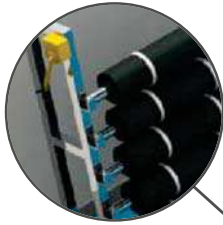

STORAGE RACK

- ▶ Bateco Storage racks for 4, 6 or 8 rolls. Can be also used for storing portable courts (Handball, Volleyball,...).

WALL PROTECTION

- ▶ Decochoc For storing area or behind the goals
- ▶ Can also be customised with digital printing on the back for sustainable effect

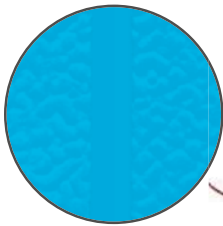

WELDING RODS

- ▶ CR 50 for Taraflex™ Range
- ▶ CR 40 for Taraflex™ Surface
- ▶ CR 60 for repairs
100 lm rod



MY LOGOS WATERJET CUTTING TECHNOLOGY

- ▶ Customise your floor with your city or club colours



PERMANENT MARKING

- ▶ TLD AQUA Paint Available in red, blue, yellow, white and black



TEMPORARY MARKING

- ▶ 3M Tapes Available in red, blue, yellow, white and black

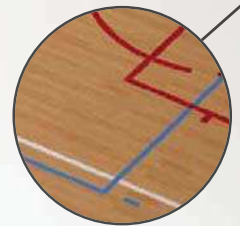

FLOOR PROTECTION

▶ Bateco
100% pure recycled PVC

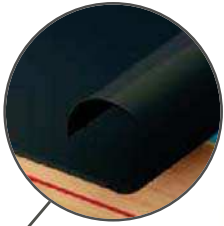

SKIRTING

▶ Vynaflex

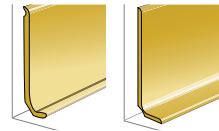
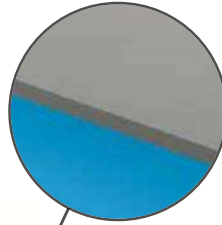



ENTRANCE CARPET

▶ ROMAT GT carpet



TECHNICAL DATA

| Description | Standard | Requirement | Units | Taraflex™ Surface | Taraflex™ Surface Mask | Taraflex™ Multi-Use 6.2 | Taraflex™ Sport M Evolution | Taraflex™ Sport M Performance | Taraflex™ Sport M Comfort |
|-------------------------------------------------------------------------------------|-----------------------|-------------|-------------------|-------------------------------------------------------------------------------|-----------------------------|-----------------------------|---------------------------------------------------------------------------------------------------|-------------------------------------------------------------------------------------|------------------------------|
| Dry-TEX™ System | - | - | - | - | - | - |  |  | - |
| Product Description | | | | | | | | | |
| Surface treatment | - | - | - | Triple-Action Protecsol® | Triple-Action Protecsol® | Triple-Action Protecsol® | Triple-Action Protecsol® | Triple-Action Protecsol® | Triple-Action Protecsol® |
| Surface complex | - | - | - | D-Max™ | 100% PVC | D-Max+™ | D-Max™ | D-Max™ | D-Max™ |
| Foam | - | - | - | - | - | CXP-HD™ | Double density CXP-HD™ | Double density CXP-HD™ | Double density CXP-HD™ |
| Thickness | EN ISO 24346 (EN 428) | - | mm | 2.1 | 2 | 6.2 | 7 | 9 | 12 |
| Weight | EN ISO 23997 (EN 430) | - | kg/m ² | 2.9 | 2.58 | 4.2 | 4.6 | 5.4 | 5.1 |
| Length* | EN ISO 24341 (EN 426) | - | lm | 26.5 Max | 20 Max | 20.5 STD | 26.5 Max | 26.5 Max | 26.5 Max |
| Width | EN ISO 24341 (EN 426) | - | lm | 1.5 | 2 | 1.5 | 1.5 | 1.5 | - |
| Sport Properties | | | | | | | | | |
| Shock absorption | EN 14808 | ≥ 25 | % | - | - | P1 | P1 | P2 | P3 |
| Impact Protection Index (IPI) | AC-P90-205 | - | % | - | - | 52 | 73 | 82 | 88 |
| Vertical deformation | EN 14809 | ≤ 3.5 | mm | ≤ 2 | ≤ 2 | ≤ 2 | ≤ 2 | ≤ 3 | ≤ 3.5 |
| Energy return | NF P 90 203 | ≥ 0.31 | m/s | ≥ 0.31 | ≥ 0.31 | ≥ 0.31 | ≥ 0.31 | ≥ 0.31 | ≥ 0.31 |
| Sliding coefficient | EN 13036-4 | 80 to 110 | - | 80 to 110 | 80 to 110 | 80 to 110 | 80 to 110 | 80 to 110 | 80 to 110 |
| Ball bounce | EN 12235 | ≥ 90 | % | ≥ 90 | ≥ 90 | ≥ 90 | ≥ 90 | ≥ 90 | ≥ 90 |
| Ball speed | ITF | - | - | - | - | - | - | - | - |
| Technical Characteristics | | | | | | | | | |
| Abrasion resistance | EN ISO 5470-1 | ≤ 1000 | mg | ≤ 350 | ≤ 350 | ≤ 350 | ≤ 350 | ≤ 350 | ≤ 350 |
| Impact resistance | EN 1517 | ≥ 8 | N/m | ≥ 8 | ≥ 8 | ≥ 8 | ≥ 8 | ≥ 8 | ≥ 8 |
| Indentation resistance | EN 1516 | ≤ 0.5 | mm | ≤ 0.5 | ≤ 0.5 | ≤ 0.25 | ≤ 0.5 | ≤ 0.5 | ≤ 0.5 |
| Classification | | | | | | | | | |
| Fire | EN 13501-1 | - | - | B _{fl} -s1 | B _{fl} -s1 | C _{fl} -s1 | C _{fl} -s1 | C _{fl} -s1 | C _{fl} -s1 |
| Anti-bacterial activity (E. coli - S. aureus - MRSA) ⁽¹⁾ | ISO 22196 | - | - | > 99% inhibits growth | | | | | |
| CE Marking | | | | | | | | | |
|  | EN 14 904 | - | - | Fire Sliding Coefficient Abrasion Resistance Rolling load Resistance | | | Fire Shock Absorption Sliding Coefficient Abrasion Resistance Rolling load Resistance | | |

The proposed specifications fall within the tolerance limits usually accepted in this sector whilst still complying with standards.

⁽¹⁾The implementation of an effective cleaning method is the best defence against infection.

* For different roll lengths please contact us.



For further information please refer to our “Taraflex™ Sports Flooring” brochure.

| Taraflex™ Tennis | Taraflex™ Badminton | | | Taraflex™ Table Tennis | | | Taraflex™ Bateco | Taraflex™ Isolsport |
|---------------------------------------------------------------------------------------------------------|-------------------------------------------------------|-------------------------------------------------------------------------------------|---------------------------------------------------------------------------------------------------------|-------------------------------------------------------|-------------------------------------------------------------------------------------|---------------------------------------------------------------------------------------------------------|---------------------|------------------------|
| | Portable | 4.5 | 7.0 | Portable | 4.5 | 6.2 | | |
| - | - | - | - | - | - | - | - | - |
| - | Triple-Action Protecsol® | PUR Protect® | Triple-Action Protecsol® | Triple-Action Protecsol® | PUR Protect® | Triple-Action Protecsol® | - | - |
| D-Max™ | 100% Pur PVC | 100% Pur PVC | D-Max™ | 100% Pur PVC | 100% Pur PVC | D-Max+™ | - | - |
| CXP-HD™ | CXP™ | - | Double density CXP-HD™ | CXP™ | - | CXP-HD™ | - | - |
| 6.2 | 3.9 | 4.5 | 7 | 3.7 | 4.5 | 6.2 | 1.5 | 1.65 |
| 3.8 | 1.95 | 2.6 | 4.6 | 1.9 | 2.6 | 4.2 | 2.05 | 1.35 |
| 24 STD | 16 STD | 20.5 STD | 26.5 Max | 16 STD | 20.5 STD | 20.5 STD | 30 Max | 45 Max |
| 1.5 | 3 x 2.7 | 1.5 | 1.5 | 1.5 | 1.5 | 1.5 | 1.5 | 2 |
| P1 | - | - | P1 | - | - | P1 | - | - |
| 52 | - | - | 73 | - | - | 52 | - | - |
| ≤ 2 | ≤ 2 | ≤ 2 | ≤ 2 | ≤ 2 | ≤ 2 | ≤ 2 | - | - |
| ≥ 0.31 | ≥ 0.31 | ≥ 0.31 | ≥ 0.31 | ≥ 0.31 | ≥ 0.31 | ≥ 0.31 | - | - |
| 80 to 110 | 80 to 110 | 80 to 110 | 80 to 110 | 80 to 110 | 80 to 110 | 80 to 110 | - | - |
| ≥ 90 | - | ≥ 90 | - | - | ≥ 90 | ≥ 90 | - | - |
| Class 5 (Fast) | - | - | - | - | - | - | - | - |
| ≤ 350 | ≤ 350 | ≤ 350 | ≤ 350 | ≤ 350 | ≤ 350 | ≤ 350 | ≤ 300 | - |
| ≥ 8 | - | - | ≥ 8 | - | - | ≥ 8 | - | - |
| ≤ 0.5 | ≤ 0.5 | ≤ 0.5 | ≤ 0.5 | ≤ 0.5 | ≤ 0.5 | ≤ 0.25 | ≤ 0.5 | ≤ 0.5 |
| C _{fl} -s1 | B _{fl} -s1 | C _{fl} -s1 | C _{fl} -s1 | B _{fl} -s1 | C _{fl} -s1 | C _{fl} -s1 | B _{fl} -s1 | C _{fl} -s1 |
| > 99% inhibits growth | | - | > 99% inhibits growth | | - | > 99% inhibits growth | - | - |
| Fire Shock Absorption Sliding Coefficient Abrasion Resistance Rolling load Resistance | Fire Sliding Coefficient Abrasion Resistance | Fire Sliding Coefficient Abrasion Resistance Rolling load Resistance | Fire Shock Absorption Sliding Coefficient Abrasion Resistance Rolling load Resistance | Fire Sliding Coefficient Abrasion Resistance | Fire Sliding Coefficient Abrasion Resistance Rolling load Resistance | Fire Shock Absorption Sliding Coefficient Abrasion Resistance Rolling load Resistance | Fire | Fire |



HARDWOOD FLOORING SYSTEMS



WHERE CHAMPIONS PLAY™

TOP COMPETITIONS TAKE PLACE ON CONNOR SPORTS®

BASKETBALL

- ▶ 2016 Olympic Men's and Women's competitions
- ▶ 2015 European Championship
- ▶ 2014 World Championship

International Federations approved Connor Sports® hardwood systems

WORLD
SQUASH

WSF



FIBA
EQUIPMENT
& VENUE



CHAMPIONS OF ENVIRONMENT

ALL CONNOR SPORTS® PRODUCTS ARE MANUFACTURED WITH THE GOAL OF MINIMIZING THE ENVIRONMENTAL IMPACT AT EVERY STATE OF THE PRODUCT'S LIFE.



Since its establishment in 1897, the Maple Flooring Manufacturers Association (MFMA) is the authoritative source of technical and general information about maple flooring and related sports flooring systems. Connor Sports® is a charter member of the MFMA and the 1st member of that group to be certified by the Rainforest Alliance.



Connor Sports® is proud to be the only ZeroWaste company in the sports flooring industry. Recycling, avoiding waste, developing innovative technology and a strong environmental consciousness are a major part of Connor Sports® corporate policy.



Connor Sports® works with FSC (Forest Stewardship Council®). This organization oversees high conservation value forest and protects the communities and indigenous people that rely on the forest. FSC ensures that everyone delivers the most environmentally friendly product.

Connor Sports® is the first MFMA member to introduce FSC environmentally conscious maple flooring.

HARDWOOD FLOORING SYSTEMS CONNOR SPORTS® 260-265

- Where champions play™ 260
- Champions of environment 261
- Champions of sport 261
- Why North American Maple? 262
- One material, three natural grades 263
- A complete range of hardwood systems 264

CHAMPIONS OF SPORT

HARDWOOD SYSTEMS FOR PROFESSIONAL TEAMS

More than half of the teams in the NBA have purchased a Connor Sports® hardwood system:



Boston Celtics



Brooklyn Nets



Philadelphia 76ers



Oklahoma City Thunder



Atlanta Hawks



Golden State Warriors



Sacramento Kings



Utah Jazz

WHY NORTH AMERICAN MAPLE?

“Hard maple has a fine, uniform texture. It is strong, stiff, hard and resistant to shock and has high resistance to shrinkage”

Wood Handbook 2010 - US department of Agriculture

2/3 of the hard maple forest are located in a few hours radius of the manufacturing facility.



Connor Sports® hand selects maple trees grown north of the 35th parallel where the shorter growing season produces a more uniform grain.

Hard-fibered

Resistant to point pressure
without abrasion

**FREE FROM SLIVERING
AND SPLINTERING**

EXTREME DURABILITY



ONE MATERIAL, THREE NATURAL GRADES



Aesthetically pure wood.
First grade is hand selected to create more cosmetic symmetry.

The most commonly specified flooring.
Second and better grade exhibits natural variations, consistent with hardwood flooring.

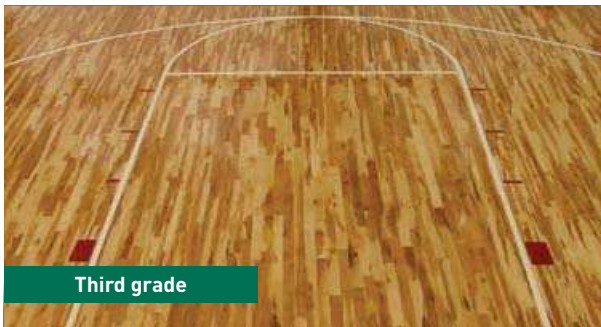
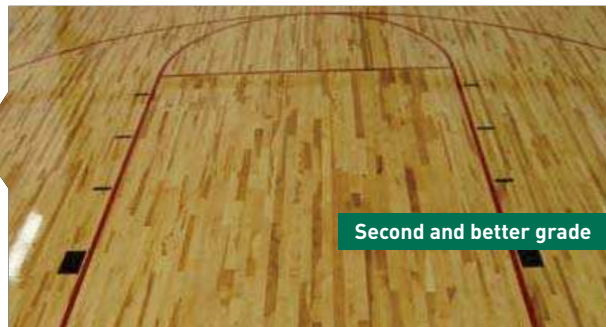

Increased tonal variation.
Third grade has the same structural integrity with increased colour variations.

**THESE 3 GRADES ARE AVAILABLE
ON ALL CONNOR SPORTS® HARDWOOD SYSTEMS**

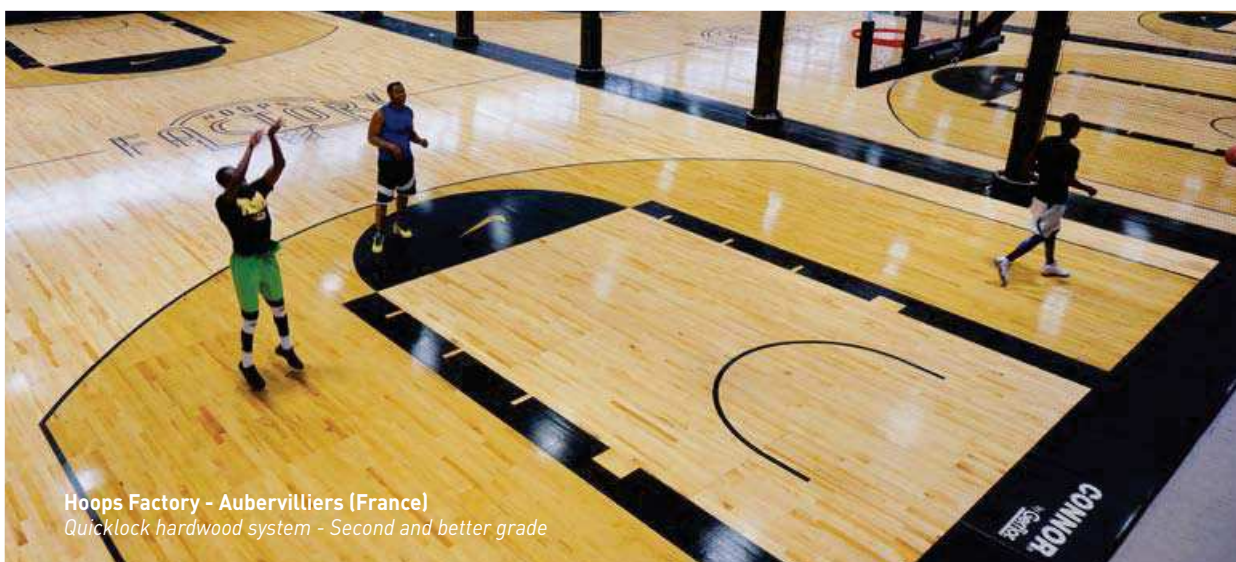

A COMPLETE RANGE OF HARDWOOD SYSTEMS

(in accordance with EN 14904 requirements)

REZILLSLEEPER FLOORING SYSTEM



FLOORING

North American Maple
Thickness 20mm / Width 57mm

RESILIENCE

12mm Rezill pads

SUBFLOOR CONSTRUCTION

Plywood sleepers
Thickness: 24mm / length of each sleeper: 2.44m

OVERALL THICKNESS: 56MM

- ✓ Good compromise between shock absorption and ball rebound
- ✓ Squash certification

➔ **Ideal for multisport activities**

ALLIANCE FLOORING SYSTEM



FLOORING

North American Maple
Thickness 20mm / Width 57mm

ANCHORAGE

Steel pin with anti-squeak collar

RESILIENCE

19mm Rezill pads

SUBFLOOR CONSTRUCTION

Double plywood pre-assembled sleepers
Panels of 2.44m x 1.22m

OVERALL THICKNESS: 57MM

- ✓ Homogeneous performances throughout the floor
- ✓ High shock absorption and ball rebound
- ✓ Anti-vibration system for comfort of play

➔ **Ideal for high intensive sport activities**

NEOSHOK FLOORING SYSTEM



FLOORING

North American Maple
Thickness 20mm / Width 57mm

RESILIENCE

19mm polyurethane Neoshok pads

SUBFLOOR CONSTRUCTION

Two layers of plywood panels
Thickness: 24mm / length : 2.44m / width : 1.22m

OVERALL THICKNESS: 63MM

- ✓ High resistance to impacts and heavy loads
- ✓ High level of shock absorption

➔ **Subfloor recommended for multipurpose activities**

CONNOR SPORTS® HARDWOOD FLOORING SYSTEMS ARE SANDED AND VARNISHED **ON SITE**:

Perfectly smooth seamless surface

Game-lines & graphics encapsulated in several coats of varnish

INJURY PREVENTION

MAINTENANCE COST REDUCTION

Narrow strips are less subjected to shrinkage than wider strips, 2-strip boards or 3-strip boards. That's why **Connor Sports® supplies 20mm x 57mm hardwood maple strips** ensuring extreme dimensional stability and durability.

- ✓ Long life span: **30 YEARS +**
- ✓ Flexible design: **UP TO 6** refinishing works



QUICKLOCK™ PORTABLE SYSTEM

FLOORING
North American Maple
Thickness 20mm / Width 57mm

RESILIENCE
13mm Powershok pads

SUBFLOOR CONSTRUCTION
Full sleeper and panel subfloor framing with laminated double sleepers

LOCKING SYSTEM
Panels of 1.23m x 2.14m – Weight: 80kgs

OVERALL THICKNESS: 83MM

✓ Easy & fast installation and removal

✓ Customised solutions

➔ Ideal for temporary use in arenas

INSTALLATION OF 1 BASKETBALL COURT IN **3^H**



OUTDOOR PLAY AREAS



PARTNER OF SPORTS FEDERATIONS

LEADING SPORT FEDERATIONS CHOOSE SPORT COURT

Outdoor surfaces for the world's most demanding athletes.



Member of the
ITF
Foundation

AS THE OFFICIAL COURT OF FIBA 3X3

Sport Court enabled FIBA to popularize the sport.



DESIGNED FOR MULTI-SPORTS

Sport Court is where teams form, friendships grow and champions start.

Sport Court surfaces are multi-use and can be outfitted for all the sports your athletes play and for all the facilities in your community.

Build a new court, retrofit an existing space, or set up portable courts for a tournament or event.



OUTDOOR PLAY AREAS SPORT COURT

266-269

- Partner of sports federations 266
- Designed for multi-sports 267
- Quick and cost-effective renovation 268
- Comfort & safety 268
- Powergame™ 269

QUICK AND COST-EFFECTIVE RENOVATION



PowerGame™ surfaces are designed to overlay outdated concrete or asphalt surfaces, transforming them to colorful play surfaces in the blink of an eye.

Sport Court floors do not require yearly, costly refinishing.

1,000 SQM = 4H + 2H
of court of installation of game line marking
with a **4-person team**

COMFORT & SAFETY



The standardized head impact test [EN1177] measures how far a child can fall before sustaining an injury.

PowerGame™ significantly improves the playing comfort in comparison to asphalt or concrete.

PowerGame™ Unparalleled safety for sports

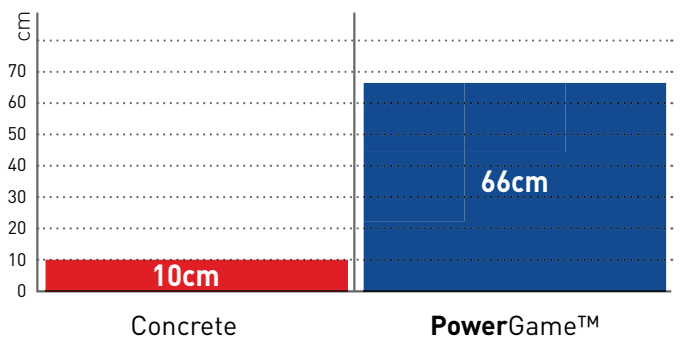

ENGINEERED FOR ATHLETES

Players develop their skills on a championship-tested surface that allows them to unleash their full potential. Sport Court delivers an unmatched combination of shock absorption, ball response, traction, and playability.

Hard courts increase injury risk for athletes.

Sport Court surfaces provide optimal comfort and protect athletes from overuse and stress injuries as well as reduce the likelihood of concussion and stress fractures.

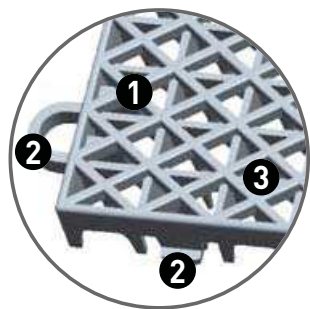
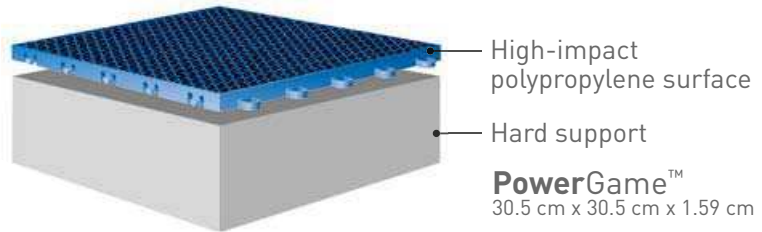

- ❶ **Double-tier** for increased shock absorption
- ❷ **Patented interlocking system** designed to support the movements of athletes and reduce the risk of injury
- ❸ **UV stabilizers** maximize colour-fastness
- ❹ **Backing** designed to promote drainage

LOWEST SKIN ABRASION
of any outdoor surface ✓



AVAILABLE COLOURS

Custom colours make the court uniquely yours.



ACCESSORIES

Polypropylene edges





.....

FINISHES AND
TECHNICAL
SOLUTIONS

..... PAGES

270/311

.....



Finishes272-287

Sport Finishes.....288-289

Technical Solutions.....290-311

FINISHES

| | |
|---------------------------------|----------------|
| Skirting solutions | 273-277 |
| Stair solutions | 278-280 |
| Profile solutions | 281-283 |
| Welding solutions | 284-285 |
| Entrance solutions | 286-287 |

Gerflor provides a complete range of solutions including skirting, stairs, profiles and welds.



FINISHES

SKIRTING AND COVING SOLUTIONS

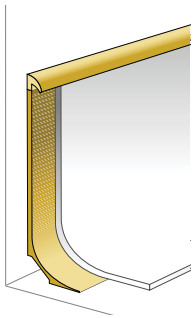

Flexible full cove former

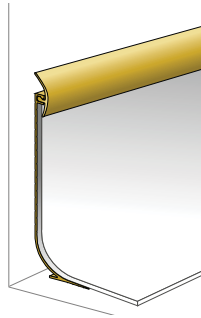

Full cove former Clip system

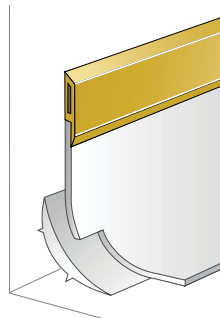

Capping strip

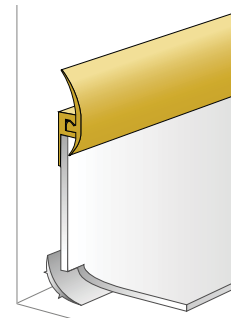

Capping strip - Clip system

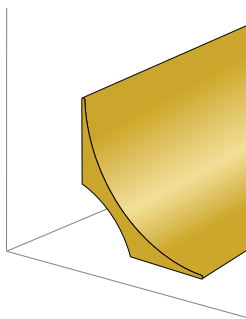

PVC Cove former

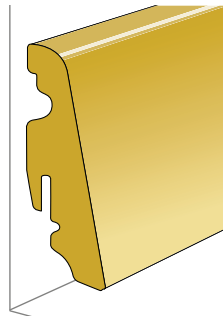

MDF Skirting

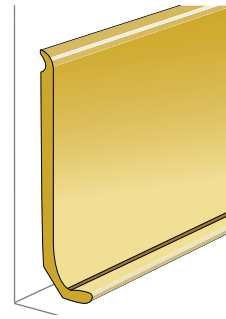

Semi-rigid skirting

There are two ways of finishing the junction between the floor and wall:

- 1** Installing the PVC covering up to the edge of the wall and using a skirting insert. **This is cost effective and time saving.**

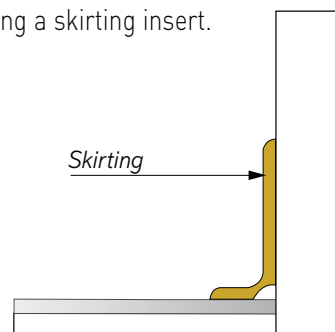



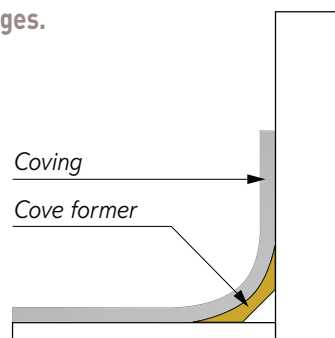



- 2** Making a cove. **This solution makes it easier to clean inside angles and edges. It gives a waterproof connection wall/floor covering.**

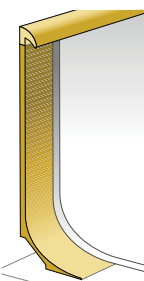
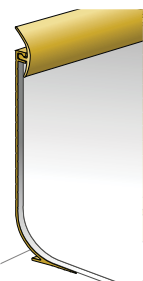
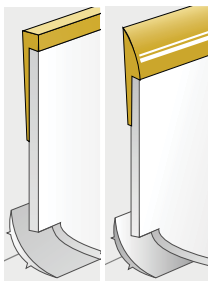

FINISHES

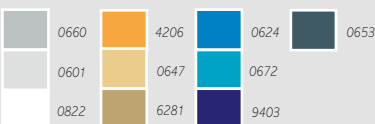
COVING SOLUTIONS

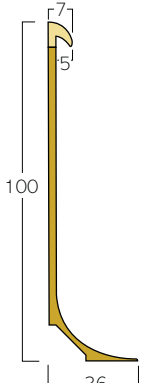
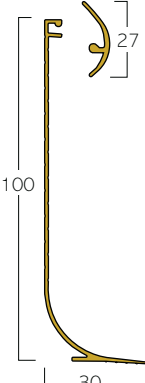
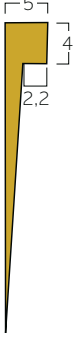
PVC Capping strips

| Description |  <p>FLEXIBLE FULL COVE FORMER</p> <p>PVC profile combining the cover former and the capping strip into a single product.</p> <ul style="list-style-type: none"> ▶ Adapted to the hospital sector and any room requiring a waterproof skirting. <p>0488</p> |  <p>FULL COVE FORMER CLIP-SYSTEM</p> <p>PVC profile combining the cover former and the capping strip into a single product.</p> <ul style="list-style-type: none"> ▶ Adapted to the hospital sector and any room requiring a waterproof skirting. <p>0487</p> |  <p>P1509 / P769</p> <p>Finishes that can be welded to the floor covering</p> <ul style="list-style-type: none"> ▶ Do not use in commercial kitchens and showers <p>0496 0493</p> |
|-------------|---------------------------------------------------------------------------------------------------------------------------------------------------------------------------------------------------------------------------------------------------------------------------------------------------------------------------------------------------------------------------------|------------------------------------------------------------------------------------------------------------------------------------------------------------------------------------------------------------------------------------------------------------------------------------------------------------------------------------------------------------------------------------|----------------------------------------------------------------------------------------------------------------------------------------------------------------------------------------------------------------------------------------------------------------------------------------------------------------------------------------------------------------------------------------------------|
| Colours |  |  |  |
| Benefits | <ul style="list-style-type: none"> ▶ Maximum floor covering thickness 4 mm ▶ Guarantees watertightness ▶ Quick to install  <p>Packaging 15 x 3 lm strips.</p> | <ul style="list-style-type: none"> ▶ Maximum floor covering thickness 4 mm ▶ Guarantees watertightness ▶ Quick & easy to install thanks to the capping strips with clip  <p>Packaging 20 x 3 lm strips.</p> | <ul style="list-style-type: none"> ▶ P769: Adapted to 2 mm floors ▶ P1509: Adapted to 2.2 mm floors   <p>Packaging 30 x 3 lm strips.</p> <p>Packaging 2 rolls of 25 lm</p> |
| Tips | <ul style="list-style-type: none"> ● Heat the skirting with a heat gun in order to match the shape of the wall ● Use either a double bonding adhesive, a dispersion contact adhesive or a double sided tape compatible with the PVC skirting | <ul style="list-style-type: none"> ● Heat the skirting with a heat gun in order to match the shape of the wall ● Use either a double bonding adhesive, a dispersion contact adhesive or a double sided tape compatible with the PVC skirting | <ul style="list-style-type: none"> ● May also be used as a floor stopping profile ● Weld with SG916 ● Use either a double bonding adhesive, a dispersion contact adhesive or a two-side adhesive compatible with the PVC skirting |

COVING SOLUTIONS

PVC Capping strips

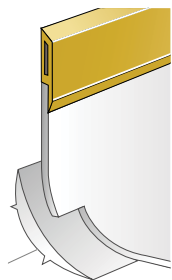

CAPPING STRIPS

Rigid capping strip with flexible lip

- ▶ Do not use in commercial kitchens and showers

0491

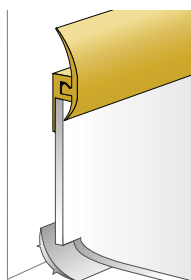

CAPPING STRIP CLIP SYSTEM

Rigid clipped finishing profile with 2 flexible lips

- ▶ Capping strip that covers the skirting

0486

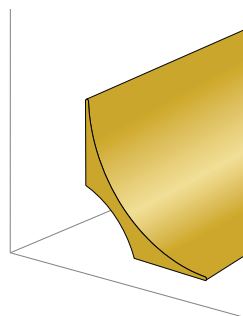

PVC COVE FORMER

NEW

This accessory allows the floor-wall cove to be formed

4011 - 4012 - 4014

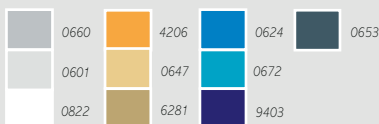

- ▶ Maximum covering thickness: 4 mm
- ▶ **Hygienic**
- ▶ **Easy to install**

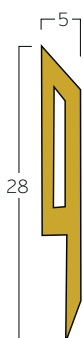

Packaging
25 x 3 lm strips.

- Slightly heat the strip if it whitens once installed
- Use a miter shear for a perfect cut
- Use either a double bonding adhesive, a dispersion contact adhesive or a double sided tape compatible with the PVC skirting

- ▶ Maximum floor covering thickness: 4 mm
- ▶ Good watertightseal for finishing floor-wall covers and floor-wall systems notably in industrial kitchens
- ▶ **Easy to install** thanks to the clip system



Packaging
20 x 3 lm strips.

- Heat the profile with a heat gun (temperature about 150°C) for the installation of the external corners
- Use a miter shear for a perfect cut
- Use SG916 for a perfect finish of the internal corners
- Slightly heat the profile if it whitens once installed
- Use either a double bonding adhesive, a dispersion contact adhesive or a double sided tape compatible with the PVC skirting

- ▶ Its rounded shape **makes it easier to clean** the floor-wall junction.
- ▶ Gives a better look
- ▶ Limits the risk of piercing the floor covering
- ▶ **Prevents accumulation** of dirt and bacteria

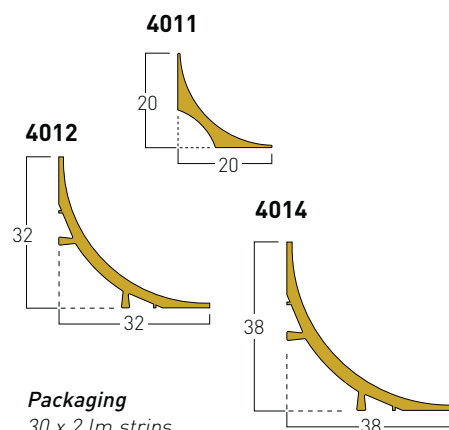

Packaging
30 x 2 lm strips.

- Use a mitre shear for a perfect cut

Colours and images are not contractual.

FINISHES

SKIRTINGS

MDF⁽¹⁾ skirting

Description

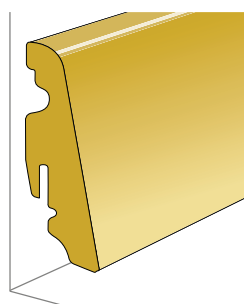

DECOR
SKIRTING

MDF⁽¹⁾ Skirting
with digital printed foil

5934

- ▶ 52 designs developed to match with main of our LVT references.
- ▶ To be installed with clip (5935) or mastic adhesive.

Benefits / Colours

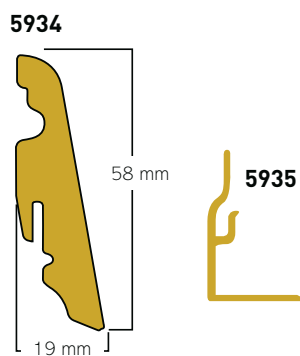

For further information relating to matching references please refer to:
Creation 70
Creation 55
Creation 30

Packaging

5934: 5 x 2,4 lm strips. / 5935: 1 box of 30 clips.

Tips

- Use a wood saw with fine teeth
- Use a mitre box for the corner
- For more information contact the customer service

⁽¹⁾ Medium Density Fiber.

⁽²⁾ Call your customer service for further information.

SKIRTINGS

Semi-rigid skirting

Description

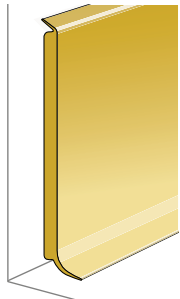

VYNAFLEX WOOD

Semi-rigid PVC skirting to be placed on the wall

0457 - 0455 - 0456

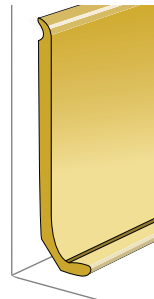

VYNAFLEX

Semi-rigid PVC skirting to be placed on the wall

0483 - 0482 - 0477

Colours

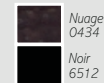
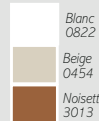
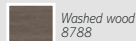
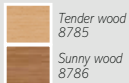

Benefits

- ▶ Wood designs
- ▶ Resistant to washing water
- ▶ 2 soft lips (60 & 100 mm)

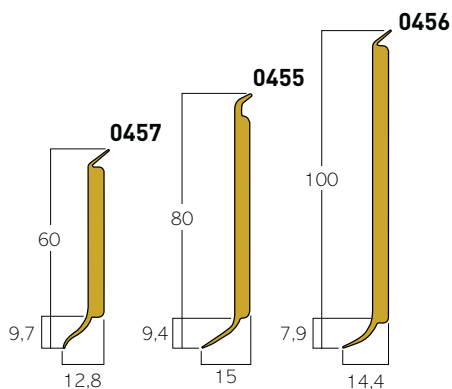

Packaging
20 x 2,5 lm strips.

- ▶ Solid colour
- ▶ Resistant to washing waters

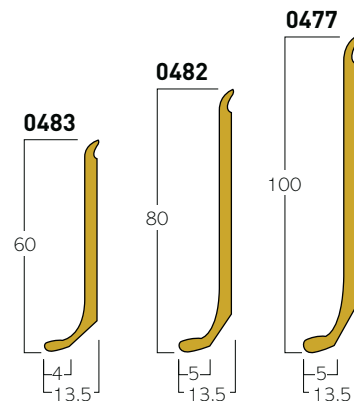

Packaging
0483 / 0477: 25 x 3 lm strips.
0482: 32 x 3 lm strips.

Tips

- Use skirting corner Cutter to handle internal and external angles
- Use either a double bonding adhesive, a dispersion contact adhesive or a double sided tape compatible with the PVC skirting
- Apply an adhesion primer if the sub-floor is porous

- Use skirting corner Cutter to handle internal and external angles
- Use either a double bonding adhesive, a dispersion contact adhesive or a double sided tape compatible with the PVC skirting
- Apply an adhesion primer if the sub-floor is porous

FINISHES

STAIR SOLUTIONS

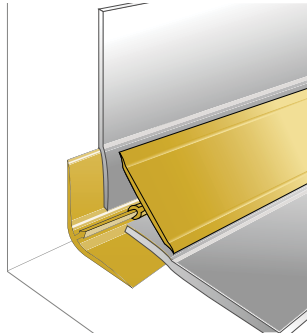

Stair clip system

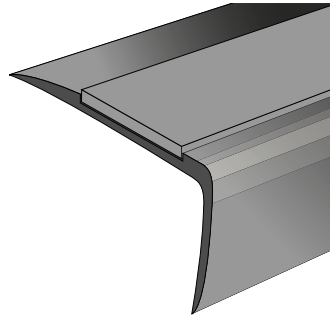

Aluminium stair nosing

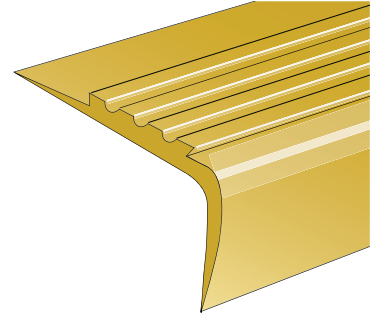

Grooved stair nosing

Gerflor has developed 2 solutions for installing a Vinyl floor on stairs to complement its range of floors:

1 Tarastep

- ▶ Install the base of the finishing clip onto the flat angle of the stair
- ▶ Install the Tarastep
- ▶ Clip the stair clip system

Adapted to rounded stair nosing.
Mill the angle for straight stair nosing.
For bird's beak stair nosing, fill the void beforehand.

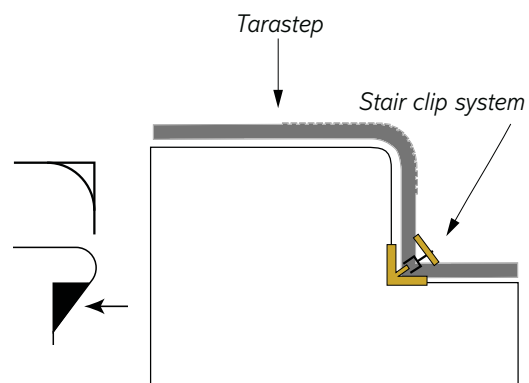







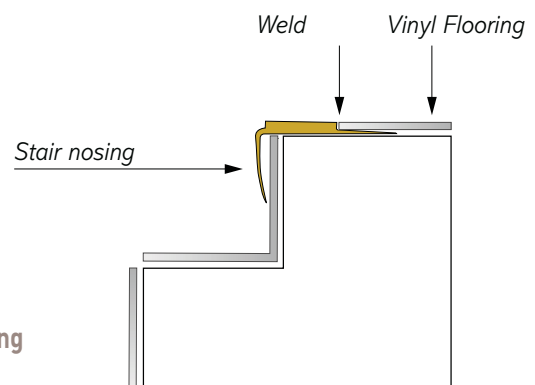



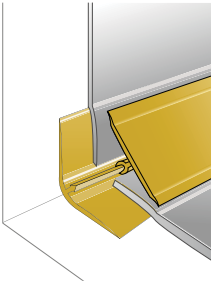
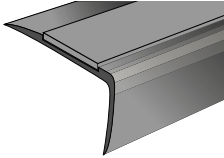





2 Stair nosing insert

- ▶ Install the vinyl flooring and the stair nosing by starting at the bottom of the stair
- ▶ Install the riser
- ▶ Install the stair nosing
- ▶ Install the flat of the stair
- ▶ Weld

Adapted to straight stair nosing, rounded stair nosing and bird's beak stair nosing.

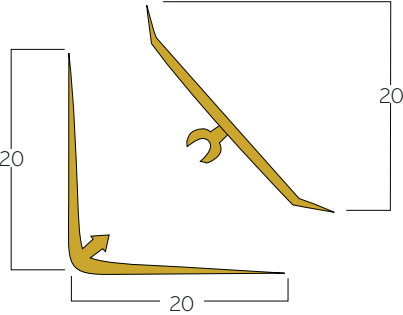
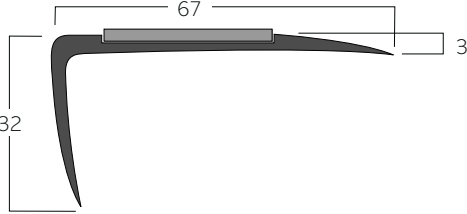

STAIR SOLUTIONS

| | PVC product installed with the Tarastep | Stair nosing insert | | | | | |
|-------------------------------------------------------------------------------------------------------|----------------------------------------------------------------------------------------------------------------------------------------------------------------------------------------------------------------------------------------------------------------------------------------------------------------------------------------------------------------------------------------------------------------------------------------------------------------------------------------------------|---------------------------------------------------------------------------------------------------------------------------------------------------------------------------------------------------------------------------------------------------------------------------------------------------------------|--------------------------------------------------------------------------------------------------|-------------------------------------------------------------------------------------------------------|---------------------------------------------------------------------------------------------------|-----------------------------------------------------------------------------------------------------------------------------------------|-----------------------------------------------------------------------------------------|
| Description |  <p>STAIR CLIP SYSTEM</p> <ul style="list-style-type: none"> ▶ Perfect stair finish, highlights the bottom of the stair <p>H138</p> |  <p>ALUMINIUM STAIR NOSING T67 ALU</p> <ul style="list-style-type: none"> ▶ Landing/stair harmony ▶ Guarantees floor covering durability <p>0503</p> | | | | | |
| Colours | <table border="0"> <tr> <td> Grey 8775</td> <td> Beige 8345</td> </tr> <tr> <td> Dark Grey 8833</td> <td> Brown 8001</td> </tr> </table> |  Grey 8775 |  Beige 8345 |  Dark Grey 8833 |  Brown 8001 | <table border="0"> <tr> <td> 0001</td> </tr> </table> |  0001 |
|  Grey 8775 |  Beige 8345 | | | | | | |
|  Dark Grey 8833 |  Brown 8001 | | | | | | |
|  0001 | | | | | | | |
| Benefits | <p>Ensures:</p> <ul style="list-style-type: none"> ▶ Better watertight seal, ▶ A better look, ▶ Durability of the floor covering ▶ Easy maintenance  | <ul style="list-style-type: none"> ▶ For a state-of-the-art stair finish ▶ Delivered with a black strip made out of carborandum for an improved anti-slipping action of the stair nosing.  | | | | | |
| Tips | <p>Packaging 9 x 2,7 lm strips.</p> <ul style="list-style-type: none"> ● <i>Tip: Slightly heat the stair clip system if it whitens once installed.</i> ● <i>Use a miter shear for perfect cut</i> ● <i>The base is installed prior to the floor covering, then clip in the cover.</i> | <p>Packaging 10 x 3 lm strips + 10 carborandum strips</p> <ul style="list-style-type: none"> ● <i>Secure with flat head cross head countersunk stainless steel screws (not included).</i> | | | | | |

FINISHES

STAIRS

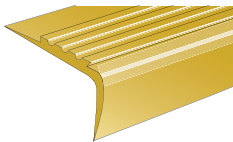
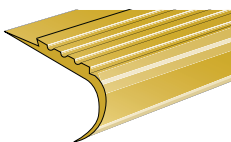
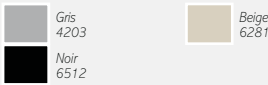
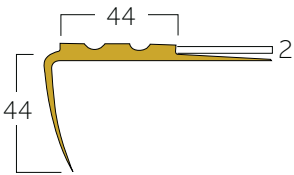
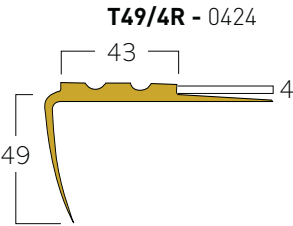
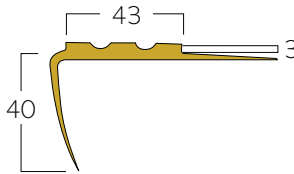
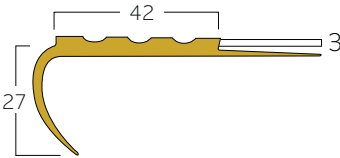
| | | Stair nosing insert | |
|-------------|----------------------------------------------------------------------------------------------------------------------------------------------------------------------------------------------------------------------------------------------------------------------------------------------------------------------------------------------------------------------------------------------------------------------------------------------------------------------------------------------------------------------------------------------|----------------------------------------------------------------------------------------------------------------------------------------------------------------------------------------------------------------------------------------------------------------------------------------|------------------------------------------------------------------------------------------------------------------------------------------------------------------------|
| Description |  <p>GROOVED PVC STAIR NOSING</p> <p>T49/4R - T49/3R - T49/2R</p> <p>0424 - 0462 - 0461</p> <p>Straight angles</p> |  <p>GROOVED PVC STAIR NOSING</p> <p>T27/3R</p> <p>0467</p> <p>Rounded angles and bird's beak</p> | <ul style="list-style-type: none"> ▶ Grooves provide anti-slip protection ▶ Landing/Stair harmony ▶ Ensures floor covering durability |
| | Colours |  | |
| Benefits | <p>T49/4R - T49/3R - T49/2R</p> <ul style="list-style-type: none"> ▶ Adapted to 2, 3 or 4 mm floor covering ▶ Weldable <p>T49/2R - 0461</p>  <p>T49/4R - 0424</p>  <p>T49/3R - 0462</p>  <p>Packaging 10 x 3 lm strips.</p> | <p>T27/3R :</p> <ul style="list-style-type: none"> ▶ Adapted to 3 mm floor covering ▶ Weldable <p>T27/3R - 0467</p>  <p>Packaging 10 x 3 lm strips.</p> | |
| | Tips | <ul style="list-style-type: none"> • Do not apply adhesive to the vertical part of the stair nosing • Double bonding | |

PROFILE SOLUTIONS

Our profiles provide solutions to several problems concerning links between floors, walls or bare spots depending on the flooring thickness and technical requirements

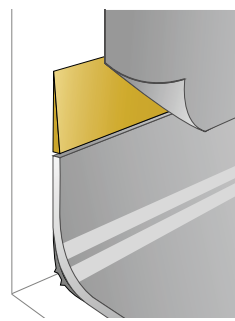

Diminishing profile

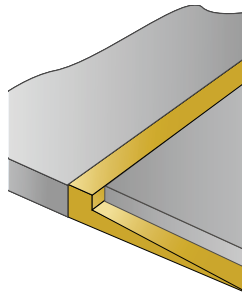

Connection profile

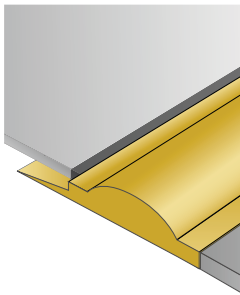

Shower threshold profile

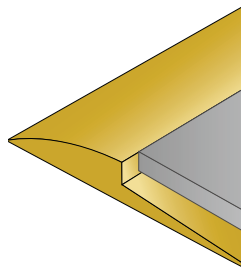

Ramp edges

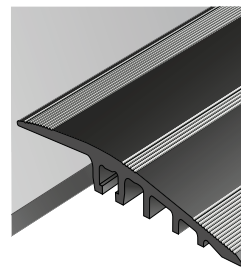

Aluminium profiles

They in particular, allow two types of connections to be dealt with:

1 Connecting profiles

The connections between two floor coverings

- ▶ Floor/Floor
- ▶ Floor/wall

Allow the link between two floor coverings with different thicknesses.

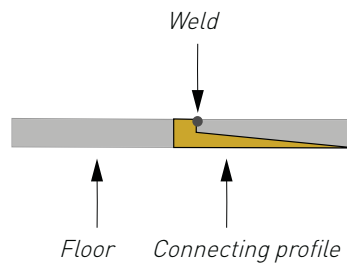

2 Ramp edges



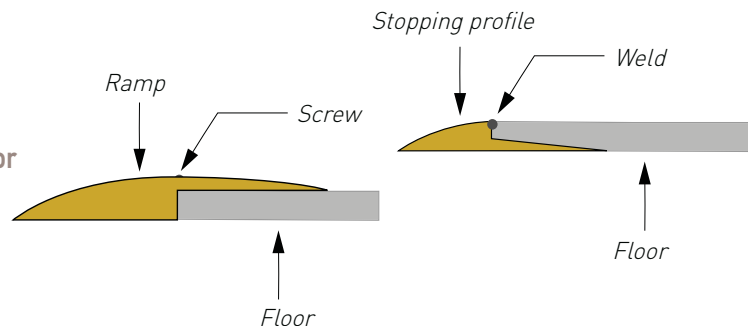

The vinyl floor/bare spot connections

Protect the edging and prevent the floor covering from delaminating.

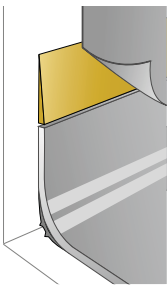
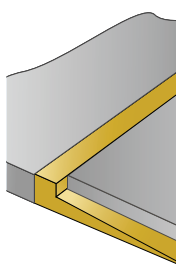
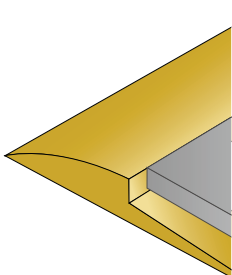

FINISHES

PVC PROFILES

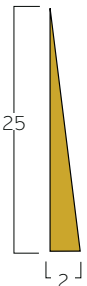
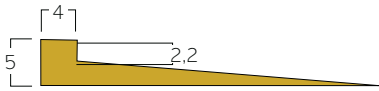
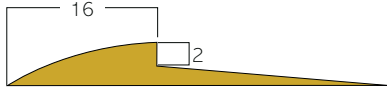
| | Floor to wall connecting profile | Floor to floor connecting profile | Ramp edges |
|-------------|-------------------------------------------------------------------------------------------------------------------------------------------------------------------------------------------------------------------------------------------------------------------------------------------------------------------------------------------------------------------------------------------------------------------------------------|--------------------------------------------------------------------------------------------------------------------------------------------------------------------------------------------------------------------------------------------------------------------------------------------------------------------------------------------------------------------------------|---------------------------------------------------------------------------------------------------------------------------------------------------------------------------------------------------------------------------------------------------------------------------------------------------------------------------------------------------|
| Description |  <p>DIMINISHING PROFILE</p> <ul style="list-style-type: none"> ▶ Coving/wall covering connection ▶ Used in laboratories, hospital shower systems, commercial kitchens <p>0490</p> |  <p>P1509</p> <ul style="list-style-type: none"> ▶ These products allow the link between two-floor coverings to be made <p>0496</p> |  <p>P769</p> <ul style="list-style-type: none"> ▶ Connect other surfaces and vinyl floors <p>0493</p> |
| Colours |  <p>Noir 6512</p> |  <p>Noir 6512 Gris 4203</p> |  <p>Noir 6512 Gris 4203</p> |
| Benefits | <ul style="list-style-type: none"> ▶ Makes it easier to link the floor covering and wall. ▶ Hygienic. Avoids bacteria accumulation ▶ Prevents the floor covering from tearing, improves durability and ensures watertightness.  <p>Packaging 2 rolls of 25 lm</p> | <ul style="list-style-type: none"> ▶ Junction between two floors of 2.2 mm and 5 mm ▶ Floor covering can be welded to profile to create a watertight seal ▶ Can also be used as a finishing profile  <p>Packaging 30 x 3 lm strips.</p> | <ul style="list-style-type: none"> ▶ Floor covering welding system ▶ Suitable for 2 mm floors ▶ Ensures watertight seal ▶ Can also be used as a capping strip  <p>Packaging 2 rolls de 25 lm</p> |
| Tips | <ul style="list-style-type: none"> • Bonding with acrylic adhesive | <ul style="list-style-type: none"> • Polychloroprene double bonding | <ul style="list-style-type: none"> • Double bonding |

ALUMINIUM PROFILES

Ramp edges

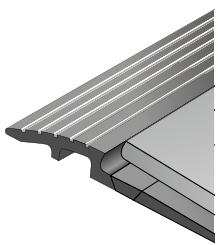

ALUMINIUM RAMP
2.8 MM

▶ Access ramps resistant to high traffic and humidity

0504

ALUMINIUM RAMP
5-6 MM

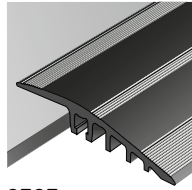

0505

ALUMINIUM CORNER
5-6 MM

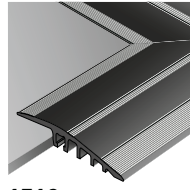

1513

LOOSELAY ALUMINIUM RAMP
5-6MM

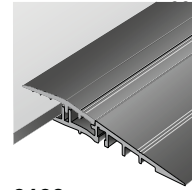

0609

LOOSELAY ALUMINIUM CORNER
5-6MM

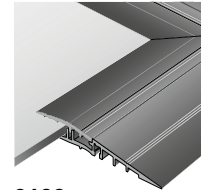

0629

▶ Access ramps resistant to high traffic and humidity



0001



0001

Product suitable for floor coverings of:
▶ 2-3 mm
(Creation 70, Creation 55, Creation 30,...)

▶ Smooth shape for more utilisation comfort
▶ Connectors for a perfect connection of 2 profiles
▶ Pre-assembled corners for an easier installation and a perfect finish

Products suitable for floor coverings of:

▶ 5-6 mm **(Attraction®, GTI MAX, Creation 70 Clic System, Creation 55 Clic System, Creation 30 Lock,...)**

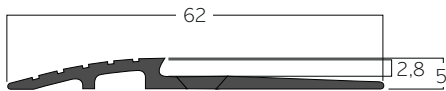

0504

Packaging
10 x 3 lm ramps

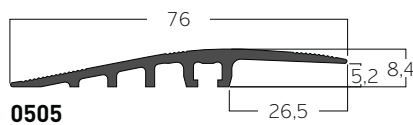

0505

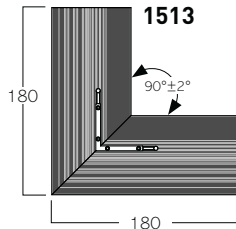

1513

Packaging
5 x 3 lm ramps (0505) / 4 corners (1513)

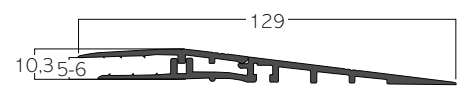

0609

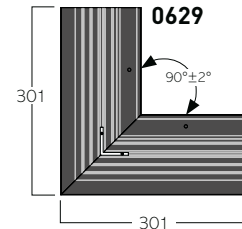

0629

Packaging
5 x 3 lm ramps (0609) / 4 corners (0629)

- Delivered with fixation kit
- Screwing of the ramp to the floor with flat cross head countersunk stainless steel screws (Aluminium ramp 5-6mm and aluminium corner)

- LooseLAY installation without damaging the subfloor (looselay ramp and looselay corner)

Colours and images are not contractual.

FINISHES

WELDING SOLUTIONS

Two types of welding solution exist:

1

Hot weld

- ▶ This is used for all types of PVC floors, for coving sport floors
- ▶ Ensures a complete watertight seal

Gerflor has a large range of rods available

The welding rod is placed in the chamfer between two floor coverings. When heated, it melts and fills the entire space to ensure complete watertight seal.

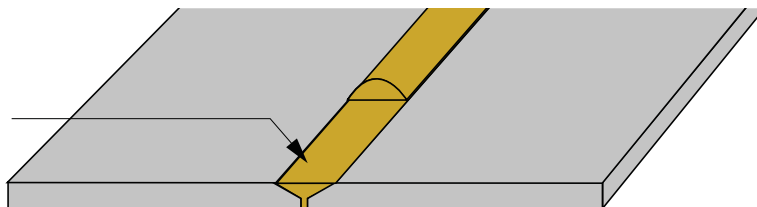

2

Cold weld

- ▶ Quick to implement
- ▶ Application on all types of PVCs except homogeneous ones
- ▶ Does not require specific equipment
- ▶ No watertightness

Gerflor offers SG916, a solution for cold treatment of joints:

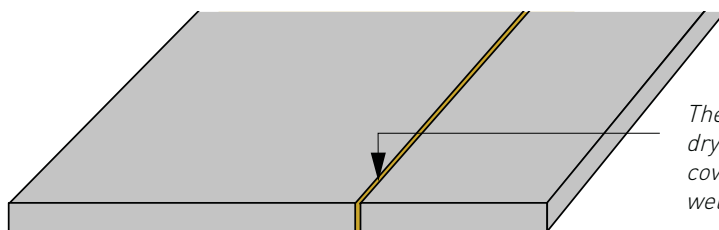

The product is inserted by dry joint between the floor coverings to ensure the weld (SG 916)

WELDS

Description

Hot weld



WELD RODS

- Ø 4 mm
- Ø 4,1 mm
- Ø 5 mm
- Ø 6 mm

WELDING ROD AND FLOORING MATCHING TOOL

<http://www.gerflor.com/servicesprofessionals/welding-rods-matching.html>



Cold weld



SG 916

- In kit - code 0548
- In tube - code 0518

Benefits

- ▶ **CR40:** Floor/floor weld - Code 0585
- ▶ **CR41:** Shower wall weld - Code H231
- ▶ **CR50:** Welding of sport floors - Code H209

Specific weld rods

- ▶ **CR50:** Weld, Tarasafe Plus, floor repairs on special order - Code H009
- ▶ **CA72:** Triangular rod for commercial kitchen floor to base welding - Code H007
- ▶ **CR60:** Welding of sport floors, repair on special order - Code H011
- ▶ **BBR40:** 100% Bio-based plasticizer rod for Mipolam Symbioz

Packaging

CR40, BBR40, CR41, CR50, CA72: 100 lm. coil
CR60: 60 lm. coil

Please contact us for further information on weld rods

- ▶ Cold treatment of joints for sheet floor coverings, **except homogeneous ones**
- ▶ **Colourless** solution used irrespective of the material colour
- ▶ **Excellent finishing quality:** prevents all visible joint line traces joint

Packaging

1 x 500 ml metal can
1 x plastic bottle
2 nozzles
3 adhesive-tape rolls of 50 lm

Tips

- For a better weld the correct grooving should be performed.
- Use an adapted nozzle (Ultra Speed Nozzle).

- Wait at least four hours before using the rooms
- Observe all the usual precautions: contains a flammable solvent.

Colours and images are not contractual.

Technical Solutions

FINISHES

ENTRANCE SOLUTIONS

Three cleaning zones to be covered at the entrance to a building

Each zone has a specific "cleaning" role:



For more information, view the range on romus.fr
or contact your Romus representative:
Head office, France:
Tel. +33 (0)1 69 79 69 79 - Fax: +33 (0)1 64 48 41 00
Email: contact@romus.fr
www.romus.fr

ENTRANCE MATS

Description

ZONE 1



RIBBED RUBBER INSERT

| | |
|-------------------------------------------------------|--|
| Romat Frequent traffic (500 p/day) | |
| Romat GT Heavy traffic (500 to 2,000 p/day) | |
| Reversible Intensive traffic (>2,000 p/day) | |

ZONE 2



TEXTILE INSERT

| | |
|-------------------------------------------------------|--|
| Romat Frequent traffic (500 p/day) | |
| Romat GT Heavy traffic (500 to 2,000 p/day) | |

RUBBER GRATE INSERT

| | |
|-------------------------------------------------------|--|
| Reversible Intensive traffic (>2,000 p/day) | |
|-------------------------------------------------------|--|

ZONE 3



DIRT-TRAPPING MAT

| | |
|----------------------------------------------|--|
| Ronet Frequent traffic (500 p/day) | |
| Roclean Heavy traffic (>500 p/day) | |

ROMAT GT FOR GTI MAX FOR PEDESTRIAN TRAFFIC ONLY



1719 - 1500 x 1000 mm

In order to keep clean areas where 6 or 5 mm floorcoverings (GTI MAX / Creation 70 Clic System / Attraction® / Creation 70 X'Press / Creation 55 Clic System) are installed we are now offering a kit with a 1500 x 1000 mm Romat GT. It can be installed without damaging the subfloor (looselay).

This kit contains:

- ▶ 1 mat
- ▶ 4 frames composed of 4 inferior profiles and 4 superior profiles
- ▶ 4 external pre-assembled corners
- ▶ 60 5-7 screws
- ▶ 1 Installation guideline

Benefits

- ▶ Eliminate dust, moisture and other residue from visitors' feet as efficiently as possible at the entrance to a building
- ▶ Prevent premature soiling and wear of floor coverings.

SPORT FINISHES

We provide finishing solutions suitable for sports floor coverings such as permanent or temporary line marking solutions.



LINE MARKING OF SPORTS FLOORS

Gerflor provides a full range of products for marking temporary and permanent game lines.

Each colour is adapted to a specific line depending on the sport in question

1 Permanent marking

Permanent marking withstands cleaning and friction from shoes

- ▶ Kits specific to each sport
- ▶ TLD Aqua (Très Longue Durée – Very Long Term) paint (retail)

2 Temporary marking

Temporary marking enables quick implementation and removal





- ▶ Coloured adhesive tape



These colours are the official line colours however customised colours can be provided upon request

SPORTS FINISHES

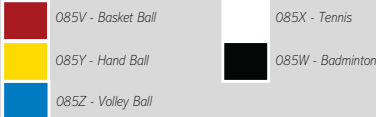
MARKING

| | Permanent marking | Temporary marking | | | | | | | | | | |
|--------------------------------------|------------------------------------------------------------------------------------------------------------------------------------------------------------------------------------------------------------------------------------------------------------------------------------------------------------------------------------------------------------------------------------------------------------------------------------------------------------------------------------------------------------------|----------------------------------------------------------------------------------------------------------------------------------------------------------------------------------------------------------------------------------------------------------------------------------------------------------------------------------------------------------------------------------------------------------------------------------------------------------------------------------------------------------------------------------------------------------------------------------------------------------------------------------------------------------------|--------------------------------------|--|----------|------------------------------|------------|----------------------------|--------|-----------------------------|------------|--------------------------|
| Description | <p>TLD AQUA PAINT KIT 1 kit for one line</p>  <p>TLD AQUA (Très Longue Durée – Long long Term) Paint was specifically developed to resist the stresses from sports being played on gymnasium floors.</p> <p>These kits include:</p> <ul style="list-style-type: none"> ▶ Paint in the same colour as official lines ▶ Hardener ▶ Protective adhesive ▶ Paint roller | <p>COLOURED ADHESIVE STRIPS</p>  <p>Coloured adhesive strips are ideal for temporary installations</p> | | | | | | | | | | |
| Colours |  <p><i>Please contact us for customised paint and kits.</i></p> | <p>Adhesive strips 3M 471</p>  | | | | | | | | | | |
| Benefits | <p>HEALTHY:</p> <ul style="list-style-type: none"> ▶ Paint with water action ▶ No risk for players and workers ▶ No substances belonging to REACH regulation (EC) ▶ Inodorous: for game line painters and for players <p>SAFE</p> <p>ROBUST</p> <p>AESTHETIC</p> <p>EASY OF USE</p> | <p>Packaging <i>H197 0005 / H373 0201 / H197 0006 / H197 0004 / H197 0002: 33 lm x 50 mm roll H211 0009: 33 lm x 80 mm roll</i></p> <table border="1"> <thead> <tr> <th colspan="2">NUMBER OF ADHESIVE STRIPS FOR 1 LINE</th> </tr> </thead> <tbody> <tr> <td>Handball</td> <td>10 yellow 3M adhesive strips</td> </tr> <tr> <td>Volleyball</td> <td>4 white 3M adhesive strips</td> </tr> <tr> <td>Futsal</td> <td>10 white 3M adhesive strips</td> </tr> <tr> <td>Basketball</td> <td>9 red 3M adhesive strips</td> </tr> </tbody> </table> <p><i>White is recommended in a single set</i></p> | NUMBER OF ADHESIVE STRIPS FOR 1 LINE | | Handball | 10 yellow 3M adhesive strips | Volleyball | 4 white 3M adhesive strips | Futsal | 10 white 3M adhesive strips | Basketball | 9 red 3M adhesive strips |
| NUMBER OF ADHESIVE STRIPS FOR 1 LINE | | | | | | | | | | | | |
| Handball | 10 yellow 3M adhesive strips | | | | | | | | | | | |
| Volleyball | 4 white 3M adhesive strips | | | | | | | | | | | |
| Futsal | 10 white 3M adhesive strips | | | | | | | | | | | |
| Basketball | 9 red 3M adhesive strips | | | | | | | | | | | |

TECHNICAL SOLUTIONS

Taradouche Shower system291-295

Taralay Premium Dry-Tex™ System296-297

Specific products.....298-305

- Isolating membranes 299
- ESD copper strip 300
- Maintenance 300-301
- Accessibility 302-303
- Clean Corner System 304-305

Safe' Cap: solution for asbestos support306-307

Adhesives and tapes.....308-309

Tools310-311

Gerflor offers a full range of technical solutions such as the shower system, copper strips, adhesives or tools in order to provide all the technical requirements on site.



TECHNICAL SOLUTIONS

SHOWER SYSTEM

A complete floor and wall solution with a choice of two floor coverings, one wall covering and seven accessories.

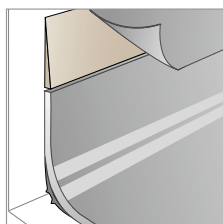

Diminishing profile - 0490

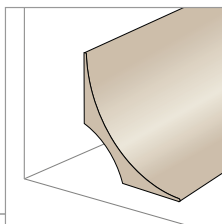

Cove former - 4011

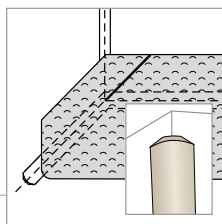

Cove former for internal wall angles CA 12 - H204



Perfect wall weld with CR41-H231



- **Safety**
Grained floor covering with slip resistance (Elegance SD, Tarasafe Ultra H₂O, Standard, Geo, Ultra Compact)
- **Watertight system**
floor/wall junction
- **System which guarantees hygiene**
- **Combination of colours**
26 wall references and 56 floor references
- **Access for all**



PVC SITAR / SITAR V Drains H112 / H113



PVC drain with inox grid - H090



Tarafoam: acoustic insulation sub-layer - 997C 6792

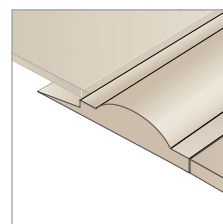

Shower threshold - 0469

The threshold has been developed in 3 colours - grey, beige and blue in order to answer to the specific requirement of Alzheimer units (no contrast).

- grey ●
- beige ○
- blue ●

TECHNICAL SOLUTIONS

SHOWER SYSTEM

PVC Drains

Description



SITAR
DRAIN

H112

Drains are made from white injected PVC.
They enable:

- ▶ Drainage of water
- ▶ Compatibility with the Shower System
- ▶ Complete watertightness by PVC/PVC bonding
- ▶ Fire rating NF-M1

SITAR V
DRAIN



H113

Colours



0001



0001

Benefits

- ▶ An **adjustable ring** depending on the screeds
- ▶ Height adjustment
- ▶ **2 outlets (horizontal and vertical)** allow for flexibility on site
- ▶ 50 mm trap seal

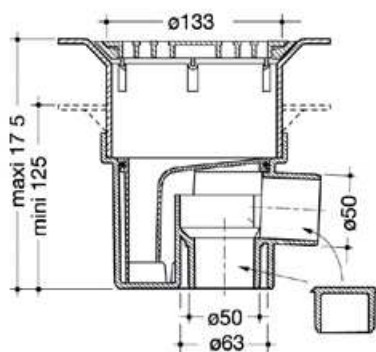

Packaging
Unit

- ▶ **Integral drain with vertical drainage**
- ▶ 50 mm trap seal

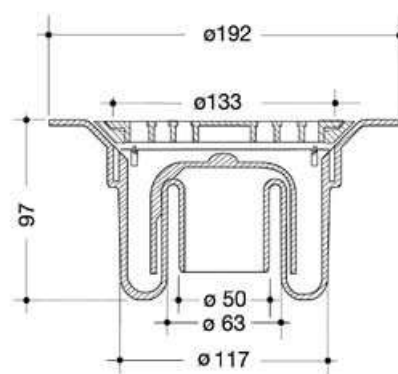

Packaging
Unit

Tips

- The floor covering is filled into the gully to a watertight seal

Colours and images are not contractual.

SHOWER SYSTEM

PVC Drain with inox grid



PVC DRAIN WITH INOX GRID

H090



- ▶ Adjustable height (up to 85 mm with extension)
- ▶ For vertical exit (or horizontal when an elbow - not supplied - is fitted)
- ▶ Flow rate: 0,6 liter per second

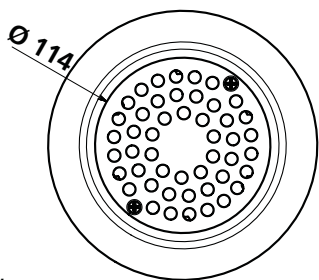
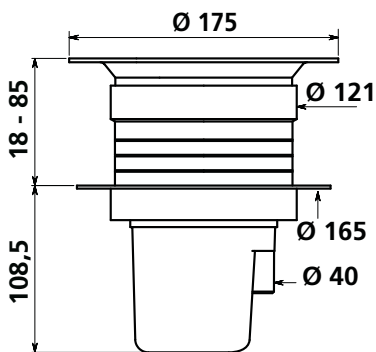

Packaging Unit

Cove former for internal angles

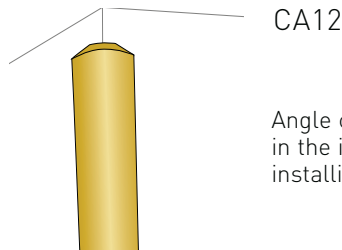

CA12

Angle cove former to be placed in the internal angles before installing the wall covering

H204



- ▶ Eliminates potential puncture damage to internal corners.
- ▶ **Size:** 12 mm

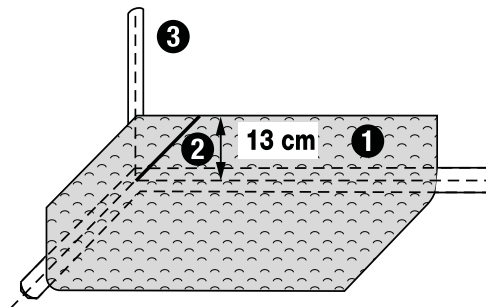

- 1 Cove the floor up to a height of 130 mm.
- 2 Cut the floor covering at 45° and weld the CR 40 rod.
- 3 Wall angle: double bonding of the CA 12 to the entire height.



Packaging
1 x 50 lm coil



The CR41 welding rod is specially adapted for shower system wall welds. Use the ultra fast nozzle

TECHNICAL SOLUTIONS

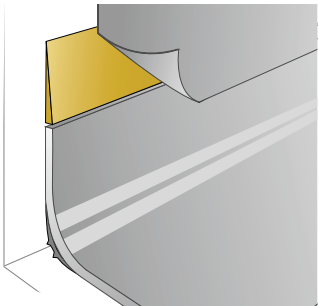
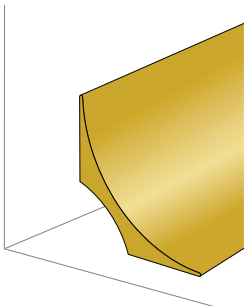
SHOWER SYSTEM

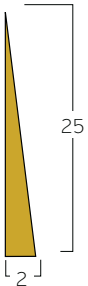
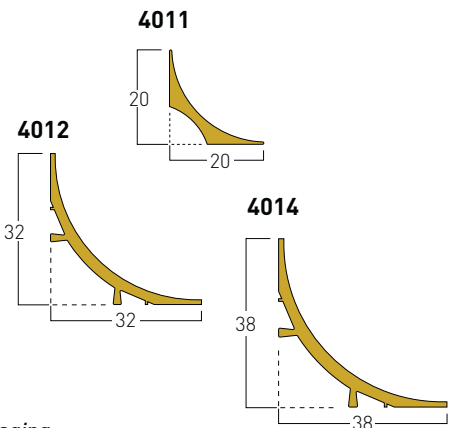
| | PVC wall covering/coving junction | Cove former |
|-------------|------------------------------------------------------------------------------------------------------------------------------------------------------------------------------------------------------------------------------------------------------------------------------------------------------------------------------------------------------------------------------------------------------------------------------------|------------------------------------------------------------------------------------------------------------------------------------------------------------------------------------------------------------------------------------------------------------------------------------------------------------------------------------------------------------------------------------------------------------------------------------------------------------------------------------------------------------------------------------------------------------------------------------------------------|
| Description |  <p>0490</p> <p>DIMINISHING PROFILE</p> <ul style="list-style-type: none"> ▶ Coving/wall covering connection ▶ Used in laboratories, hospital shower systems, commercial kitchens |  <p>4011 - 4012 - 4014</p> <p>PVC COVE FORMER</p> <p>NEW</p> <p>This accessory allows the floor-wall cove to be formed</p> |
| Colours |  <p>Noir 6512</p> |  <p>Noir 6512</p> |
| Benefits | <ul style="list-style-type: none"> ▶ Makes it easier to link the floor covering and wall. ▶ Hygienic. Avoids bacteria accumulation ▶ Prevents the floor covering from tearing, improves durability and ensures watertightness.  <p>Packaging 2 x 25 lm rolls</p> | <ul style="list-style-type: none"> ▶ Enables coving and allows watertightness ▶ Its rounded shape makes it easier to clean the floor/wall junction ▶ Offers a better look ▶ Limits the risk of piercing the floor covering ▶ Prevents accumulation of bacteria  <p>4011 (height 20, width 20)</p> <p>4012 (height 32, width 32)</p> <p>4014 (height 38, width 38)</p> <p>Packaging 30 x 2 lm strips</p> |
| Tips | <ul style="list-style-type: none"> ● Bond with acrylic adhesive | <ul style="list-style-type: none"> ● Only a single 45° angle is cut ● Double bonding (polychloropene type) ● Use a miter shear for a perfect cut |

SHOWER SYSTEM

PVC shower threshold profile

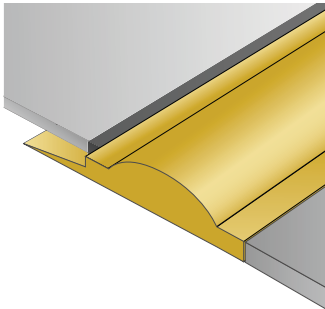

PVC SHOWER THRESHOLD PROFILE

- Makes the junction between a floor covering and a shower covering

0469

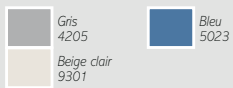

- Allows welding of 2 mm or 3.5 mm floor covering thanks to the **tab** system
- **Weld** system with the covering which ensures perfect **watertightness**

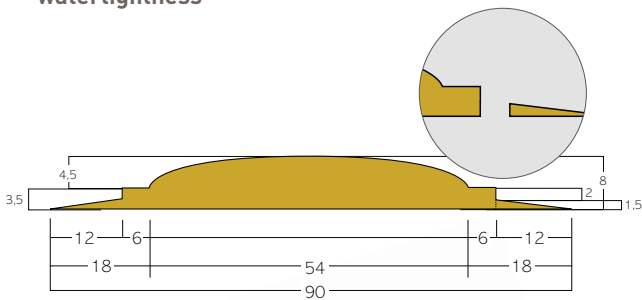

Packaging
10 x 3 lm strips

- The tab can be cut to suit a thicker floor
- Polychloroprene double bonding
- Application of sealant around the door jamb (PU or MS polymer sealant)

Colours and images are not contractual.



TECHNICAL SOLUTIONS

TARALAY PREMIUM DRY-TEX™ SYSTEM*

THE ALL-IN-ONE MOISTURE SOLUTION _____



TARALAY PREMIUM DRY-TEX™ SYSTEM*

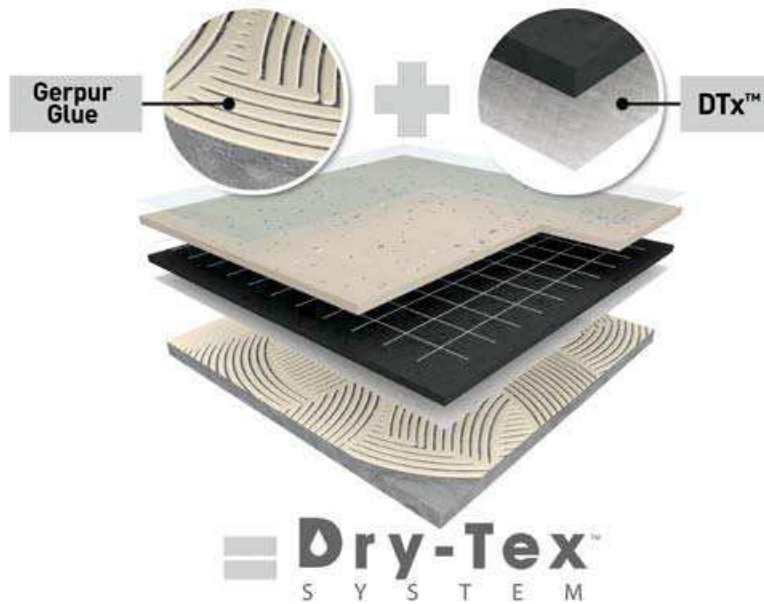

All the performance of Taralay Premium

See page 44



4343 Tokelau



8053 Anambas



4004 Pago



4003 Tao

And much more for any slab with high moisture

SAVE MONEY

- ✓ up to 70% cost savings compared to other third-party mitigation systems

SAVE TIME

- ✓ the only one-step, full-spread adhesive solution

RELIABLE SOLUTION

- ✓ over 500 000 sqm installed since 2009 with the same system used in Taraflex® Sports Flooring

HIGH PERFORMANCE SYSTEM

- ✓ proven to resist up to 98% RH

* For any project please contact your Sales Representative for further technical information!

TECHNICAL SOLUTIONS

SPECIFIC PRODUCTS

Gerflor provides a set of products providing solutions to specific problems such as accessibility, insulation, maintenance of floors and electrical conductivity of our floors.



Isolating membranes



ESD copper strip



Accessibility







Gerflor Corner System

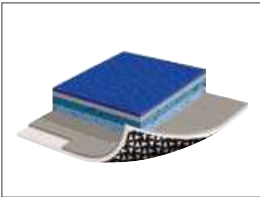

Maintenance



SPECIFIC PRODUCTS - ISOLATING MEMBRANES

| | Isolsport | Bateco | Protection | Tarafoam |
|-------------|------------------------------------------------------------------------------------------------------------------------------------------------------------------------------------------------------------------------------------------------------------------------------------------------------------------------------------------------------------------------------------------------------------------|------------------------------------------------------------------------------------------------------------------------------------------------------------------------------------------------------------------------------------------------------------------------------------------------------------------------------------------------------------|-----------------------------------------------------------------------------------------------------------------------------------------------------------------------------------------------------------------|-------------------------------------------------------------------------------------------------------------------------------------------------------------------------------------------------------------------------------|
| Description | <p>VINYL ISOLATING MEMBRANE</p>  <p>0829 0002</p> <p>Specially designed for sports</p> <p>For installation on concrete subfloors</p> | <p>PROTECTIVE SURFACE</p>  <p>H375 6801</p> <p>Specially designed for sports</p> <p>Suitable for gymnasium / reception hall versatility</p> | <p>FLOOR PROTECTION NEW</p>  <p>058X 0001</p> <p>Preserve the floors laid down until the site is delivered.</p> | <p>COMFORT VERSION OF THE SHOWER SYSTEM</p>  <p>997C 6792</p> |
| Benefits | <ul style="list-style-type: none"> ▶ Vinyl isolating membrane, double side on non woven glass fibre with backing design made up of 3-branch star foam pads. ▶ Its design enables loose laying on sensitive subfloors (risks of humidity, coated, etc.) when it is associated with a Taraflex sporting floor. The raised effect allows humidity to circulate. ▶ Thickness: 1.7mm | <ul style="list-style-type: none"> ▶ Protective surface made from black calendared and grained plasticised vinyl. ▶ Taraflex Bateco is especially designed to protect sport floors in the event of non-sports use of the room. It prevents marking by chairs, tables, heels on the sport floor. ▶ Thickness: 1.5mm | <ul style="list-style-type: none"> ▶ Effective protection against scratches, stains, slip and other external stresses. ▶ Good hold on the floor for a safe use ▶ Reusable | <ul style="list-style-type: none"> ▶ Provides acoustic insulation for the shower system (15 dB) and comfort under foot. ▶ Thickness: 2mm |
| Tips | <p>Packaging 1 x 45 lm roll</p> <ul style="list-style-type: none"> ● Bond well at doors with PU adhesive to prevent delamination. ● Keep the raised surface, floor side, on the periphery ● Edge to edge installation ● Bond vinyl floors with Gertec adhesive | <p>Packaging 1 x 30 lm roll</p> <ul style="list-style-type: none"> ● Edge to edge installation ● Strips can be secured with single-sided adhesive tape | <p>Packaging Roll of 1 x 50 lm - 50 m²</p> | <p>Packaging Roll of 2 m x 20 lm - 40 m²</p> <ul style="list-style-type: none"> ● Levels out around the edge of the room ● Acrylic bonding ● Edge to edge installation |

Colours and images are not contractual.

TECHNICAL SOLUTIONS

SPECIFIC PRODUCTS - ACCESSORIES

| | Copper strip | Sport floor maintenance |
|-------------|------------------------------------------------------------------------------------------------------------------------------------------------------------------------------------------------------------------------------|-----------------------------------------------------------------------------------------------------------------------------------------------------------------------------------------------------------------------------------------------------------------------------------------------------------------------------------------|
| Description |  <p>ESD COPPER STRIP</p> <p>Copper strip enabling earthing</p> <p>0586 0001</p> |  <p>TRACIFLEX</p> <p>085P 0001</p> <ul style="list-style-type: none">▶ Multipurpose detergent for cleaning the vinyl sport floors (shoe marks and contact marks)▶ Also suitable for floors which are difficult to clean |
| Benefits | <ul style="list-style-type: none">▶ For electro-conductive floor coverings such as Elegance EL5, Technic EL5, Accord EL7▶ Width 10 mm, thickness 0.08 mm. <p>Packaging 1 x 200 lm roll</p> | <ul style="list-style-type: none">▶ Removes resin from Handball courts▶ Recommended in sport room  <p>Packaging 1 l can</p> |
| Tips | <ul style="list-style-type: none">● Prevent discontinuity between the angles by folding it back onto itself | <ul style="list-style-type: none">● Traciflex may be sprayed on stubborn stains |

SPECIFIC PRODUCTS - ACCESSORIES

Sport floor maintenance



DYNATECH TROPHY

085E 0001

- ▶ Multipurpose detergent for cleaning the vinyl sport floors (shoe marks and contact marks)
- ▶ Also suitable for floors which are difficult to clean

- ▶ For all sport floors



Packaging
5 l can

Protocolsol® Floor Maintenance



SPRAY
TARACLEAN

085A 0010

- ▶ Spray cleaner to remove occasional and tough stains

- ▶ Suited to all types of floors treated with Protocolsol®
- ▶ Easy and quick to use

Packaging
Box of 12 pieces

Colours and images are not contractual.

TECHNICAL SOLUTIONS

SPECIFIC PRODUCTS - ACCESSIBILITY



SPECIFIC PRODUCTS - ACCESSIBILITY



Warning Surfaces

Weldable tactile warning strip

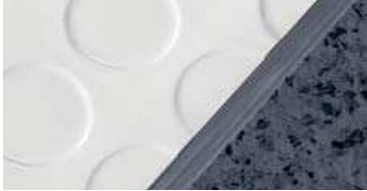

Formats: 400 x 1350 mm - code: L009 /
400 x 2000 mm - code: L008

Self-adhesive tactile tile
ideal for renovation projects

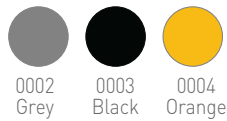

Formats: 420 x 825 mm - code: 058D /
420 x 1350 mm - code: 058F

Self-adhesive tactile studs
for a more aesthetic look



Format: 5 h x 25 Ø mm - code: 058K



Self-adhesive Orientation Strip

Linear Guiding Strip



Format: 600 x 150 mm - code: 058I

Vibration Guiding Strip



Format: 600 x 150 mm - code: 058J

Other colours available (available on order of 2 packs for the tiles or 1 kit for the studs):



Signage

Personalised cut-to-size system



For more information,
please refer to the
"A Global Solution for
Accessibility" brochure.

TECHNICAL SOLUTIONS

SPECIFIC PRODUCTS - CLEAN CORNER SYSTEM

AN INNOVATIVE CORNER SYSTEM



Contamination control in technical platforms and clean rooms is an ongoing issue. Corners, in particular, are the focal point of most negligence in respect of hygiene rules:

- If not properly welded, they tear or subside under the weight of traffic;
- Their hollow shape makes them difficult to clean and decontaminate;
- Weakened by use, they eventually lose their watertightness.

Based on the experience of professionals in the field, Gerflor has developed **Clean Corner System**: a patent pending innovative corner solution stemming from several years of research and development (system only functioning with Gerflor floors).

With ultra-resistant and versatile profiles (picture 1) **Clean Corner System** can be used for all your projects with a perfect result (picture 2).

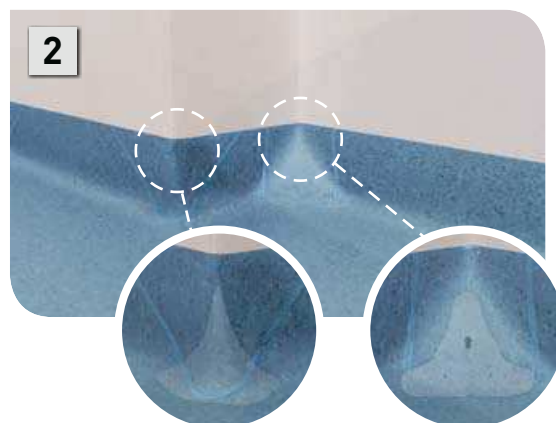

PATENT PENDING SYSTEM

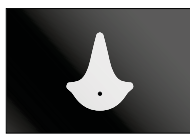

058R Profile for external corners^[1]



058S Profile for internal corners^[2]

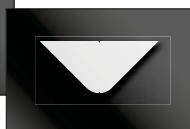

058T Installation templates kit

^[1] External angle is covered by the respective pending patent applications: WO2016/005695 A1, FR3023313

^[2] Internal angle is covered by the french pending patent application FR3013065

A TECHNOLOGY SERVING HYGIENE

Suitable for all Gerflor PVC floors, **Clean Corner System** technology makes it possible to meet Healthcare professional requirements and ensure full compliance with Industrial Clean Room hygiene and decontamination guidelines.

Internal & external corners
and Installation templates kit



Gerflor Floorings
(Mipolam, Taralay,
Tarasafe,...)



Wall Coverings
(Mural Ultra, SPM
Decochoc & Decoclean)



CLEANER AND MORE DURABLE INSTALLATIONS

REGARDLESS OF THE CONFIGURATIONS AND CONSTRAINTS FOR USE

SPECIFIC PRODUCTS - CLEAN CORNER SYSTEM

FOR UNIQUE RESULTS



WATERTIGHT

- Compliant with GMP
- Suitable for E2 and E3 zones
- Easy coving
- Limited and easy welding



RESISTANT & DURABLE

- Ultra-resistant bi-material corner profiles



CLEAN

- Quick and easy cleaning and decontamination
- Easy manoeuvring of twist upright vacuum cleaner
- No blind spot



VERSATILE

- Suitable for all Gerflor floors
- Suitable for all skirting heights (7 to 15 cm)
- Suitable for all cove formers (20 x 20 mm to 38 x 38 mm)
- Suitable for all angles (85° to 95°) with or without coving sections



ATTRACTIVE

- Neat and uniform design for all your corners



TECHNICAL SOLUTIONS

NEW

SAFE'CAP: DRILLING CAPSULE FOR ASBESTOS SUPPORTS

Asbestos has been recognised as carcinogenic, however it was not until 2002 that its use was banned in the European Union. A large number of buildings constructed prior to that are still operational and need to be renovated. The risks associated with inhalation of asbestos fibres (asbestos related lung cancer, asbestosis, mesothelioma, ...) affect both the users and workers at the renovation sites.

It is therefore essential to take all necessary measures to protect workers who may be in contact with asbestos fibres.

What solutions are used today to drill an asbestos support ?

VACUUM CLEANER WITH HIGH DENSITY FILTER

- > Bulky
- > Expensive
- > Needs electricity at the site



COVERING THE AREA TO BE DRILLED WITH WALLPAPER ADHESIVE / GEL

- > Messy
- > No set procedure
- > Not safe enough



Drilling with Safe'Cap



Safe' Cap

THE SOLUTION FOR DRILLING YOUR ASBESTOS FLOORS AND WALLS WITH COMPLETE SAFETY!



SAFE

- Collects asbestos dust
- Tested for dust concentration lower than the French public health threshold of 5 fibres per litre⁽¹⁾



ECONOMICAL

Quick and handy: No need for special equipment for asbestos protection (vacuum cleaner and dust-proof overalls)⁽²⁾



EASE OF USE

Locate, Fit, Drill:
Drilling asbestos **floors & walls***
is now easier!



CLEANLINESS

- Encapsulated dust
- No trace of asbestos on the support

* For more information, please refer to Gerflor's Installation Guidelines.

⁽¹⁾ These measurements have been taken by an accredited body. They can be used as a reference for drafting the procedures of companies when they carry out works in accordance with the Safe'Cap capsule installation guideline.

⁽²⁾ This procedure can be partially carried out without using any respiratory protection provided the company has validated its procedures by conclusive dust concentration measurements.



SINGLE USE

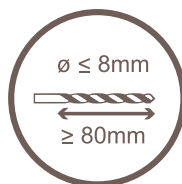
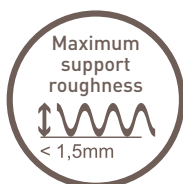



PACKAGING OF
36 CAPSULES

TECHNICAL SOLUTIONS

ADHESIVES AND TAPES

Gerflor has developed specific bonding solutions to make it easier to install its products.

| Adhesives | | | | |
|-------------|----------------------------------------------------------------------------------------------------------------------------------------------------------------------------------------------------------------------------------------------------------------------------|-----------------------------------------------------------------------------------------------------------------------------------------------------------------------------------------------------------------------------------------------------------------------------------------------------------------------------------------------------------------|---------------------------------------------------------------------------------------------------------------------------------------------------------------------------------------|--------------------------------------------------------------------------------------------------------------------------------------------------------------------|
| Description | <p>GERPUR M</p>  <p>086C 0083</p> <p>Specially designed for sports</p> <p>Only for Dry Tex™ System (bonding of Taraflex sport floors with non-woven backing)</p> | <p>GERTEC</p>  <p>0991 0991</p> <p>Application on floors with old vinyl floor covering for renovation or on Isolsport</p> | <p>GERFIX SUPER E 120</p>  <p>0973 0973</p> <p>Apply on a hydraulic base or resurfacing</p> | |
| | Benefits | <ul style="list-style-type: none"> ▶ Bonding on new and old humid concrete subfloor ▶ Mono component PU adhesive, reactive to humidity which enables the DTX material to be fully bonded in humid environment (no restriction of humidity levels with the exception of surface water) ▶ Consumption: 400 to 450g/m² | <ul style="list-style-type: none"> ▶ Acrylic adhesive ▶ Adapted to Isolsport and other sport floors ▶ Consumption: 150 to 200 g/m² | <ul style="list-style-type: none"> ▶ Acrylic adhesive ▶ Consumption: 300 to 350g/m² |
| | | Tips | <p>Packaging 15 kg bucket</p> <ul style="list-style-type: none"> ● To be applied with ergonomic trowel for rigid adhesive and B1 blade | <p>Packaging 20 kg bucket</p> <ul style="list-style-type: none"> ● To be applied with a stiff aluminium trowel and blade A4 Standard TKB |

ADHESIVES AND TAPES

Hook & loop and double sided tapes for textile backing

V107



0556 0001

D75



0534 0001

Width: 107 mm

Width: 75 mm

- ▶ V107 and D75 enable installation of vinyl floor coverings with textile backing on the perimeter and under joints.
- ▶ Time saving and cleanliness by comparison with a bonded system.
- ▶ No gumming time and no smell.

Packaging
4 x 25 lm rolls

Packaging
1 x 25 lm roll

Non-migrating double sided tapes

FIX & FREE
100 **NEW**



0584 0001

Width: 100 mm

FIX & FREE
740 **NEW**



058W 0001

Width: 740 mm

- ▶ New double-sided tapes in order to install and uninstall our floorcovering easily, without damaging the subfloor. This is particularly useful for "ephemeral areas" (in retail for instance) of for renovation of subfloor containing asbestos.
- ▶ Fix & Free 100 is suitable for textile backing floorcovering. Fix & Free 740 is suitable for Creation Clic and GTI.
- ▶ Time saving and cleanliness by comparison with a bonded system.
- ▶ No gumming time and no smell.

Packaging
1 x 50 lm roll

Packaging
1 x 25 lm roll

Double sided tapes for sport floors

D 200 / D 300



H208 0007 / 085R 0001

Width: 100 mm

- D 200: Special double sided tape for wood floors**
- D 300: Special double sided tape for concrete**

- ▶ Adapted to temporary installation on wood floors or concrete
- ▶ Requires a test on site for validation

Packaging
1 x 50 lm roll

Required material:
● Double side tape reel

AT7



H206 0001

Width: 100 mm

Single-side tape

- ▶ Black
- ▶ Bonds without leaving marks, non migrating

- Holds strips:**
1. During non sportive events
 2. Enables the material to be secured on the tube at the time of winding
 3. Holds strips during the storage time

Packaging
1 x 33 lm roll

Required material:
● AT7 tape reel

Refer to the product glossary for information on colours and packaging

TECHNICAL SOLUTIONS

TOOLS

Gerflor provides tools to facilitate installation and treatment of floor coverings.

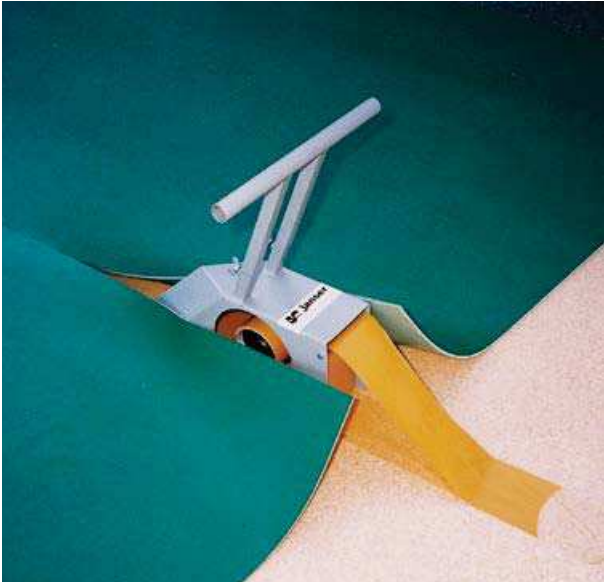

TOOLS - SPORT

Storers



DOUBLE-SIDED TAPE REEL

Accessories used for unwinding double-sided tapes D200, D300.

H372 0001



WALL ATTACHED FLOOR COVERING STORAGE

Gerflor also offers:
Wall attached floor covering storage for 4, 6 or 8 rolls
Width: 1.5 meters*



SINGLE SIDE TAPE REEL

Accessories used for unwinding single-sided tape AT7 and holding BATECO strips together.

H367 0003



SERVING TROLLEY - STORERS

A serving trolley; floor covering storer on wheels for 6 or 8 rolls. Motorised. Unwinds, winds up, raises and stores the floor covering rolls. Adapted to Bateco and sports floors.
Width: 1.5 meters*

**2 meters available on special request*



RESTRAINING STRAP VELCRO STRIPS

L=2.10m for 60 cm dia. rolls approximately.

H295 0001



A RANGE OF ADDITIONAL ACCESSORIES FOR ASSISTING INSTALLATIONS (pressure rollers, strap hoists,...)

*Item codes: refer to glossary.
For more information, please contact the Gerflor sales department.*



.....
SPECIFICATIONS,
INSTALLATION
&
MAINTENANCE

..... PAGES

312/323
.....







Gerflor specifications314-319

Installation & maintenance320-323

GERFLOR SPECIFICATION

HEALTHCARE - HOSPITAL - CLINIC - RETIREMENT HOME







| | HOMOGENEOUS FLOORINGS | | MULTILAYERED FLOORINGS | | | | | | | |
|---------------------------------------|-------------------------------------------------------------------------------------------|-------------------------------------------------------------------------------------------|----------------------------------------------------------------------------------------------------------------------------------------------------------------------------------------|-------------------------|---------------------------------------------------|-------------------------|-------------------------|-------------------------|---------------------------------------------------------------------------------------------|-------------------------|
| |  Compact |  Compact |  Comfort  Compact | | | | | |  Comfort | |
| | Homogeneous Flooring (Evercare™) | Homogeneous Flooring (PUR/PU) | Taralay Premium Comfort | Taralay Element Comfort | Taralay Impression Comfort Taralay Uni Comfort | Taralay Initial Comfort | Taralay Premium Compact | Taralay Element Compact | Taralay Impression Compact | Taralay Initial Compact |
| HEALTHCARE - HOSPITAL - CLINIC | | | | | | | | | | |
| Reception | • | | | | | | • | • | | |
| Corridors | • | | • | • | | | • | • | | |
| Waiting room | • | | • | • | • | | • | • | • | • |
| Bedroom | • | | • | | • | | | | • | • |
| Bathroom - Toilets | | | | | | | | | | |
| Carerom - Medical - Sick bay | • | | • | | • | | • | | • | • |
| Rehabilitation room | | | • | • | • | | | | | |
| Surgery | • | | • | | • | | • | | • | • |
| Theatre block | • | | • | | | | • | | | |
| Intensive care unit | • | | • | | | | • | | | |
| Radiotherapy - Laboratory | • | | | • | | | • | | | |
| Laundry - Store room | | | | | | | | | | |
| Stairs | | | | | | | | | | • |
| RETIREMENT HOME | | | | | | | | | | |
| Reception | • | | | | | | • | • | | |
| Corridors | • | | • | | | | • | • | | |
| Bedroom | • | | • | | • | | • | | | |
| Bathroom - Toilets | | | | | | | | | | |
| Living room | | | • | • | • | | | | | |
| Laundry - Store room | | | | | | | | | | |
| OFFICE - ADMINISTRATION | | | | | | | | | | |
| Reception | • | | | | | | • | • | | |
| Office | | | • | | • | | | | | |
| Bathroom - Toilets | | | | | | | | | | |
| Meeting room - Board room | | | • | | • | | | | | |
| Computer room | | | | | | | | | | |
| Stairs | | | | | | | | | | • |

- GERFLOR's recommendation
- Other possible solutions

GERFLOR SPECIFICATION

EDUCATION - INDUSTRY - HOTEL - RESTAURANT







| | HOMOGENEOUS FLOORINGS | | MULTILAYERED FLOORINGS | | | | | | | | |
|------------------------------|---------------------------------------------------------------------------------------------------------------------------------------------------------------------|-------------------------------|-------------------------------------------------------------------------------------------------------------------------------------------------------------------------|-------------------------|---------------------------------------------------|-------------------------|-------------------------|-------------------------|----------------------------|-------------------------------------------------------------------------------------|----------|
| |   | |   | | | | | | |  | |
| | Homogeneous Flooring (Evercare™) | Homogeneous Flooring (PUR/PU) | Taralay Premium Comfort | Taralay Element Comfort | Taralay Impression Comfort Taralay Uni Comfort | Taralay Initial Comfort | Taralay Premium Compact | Taralay Element Compact | Taralay Impression Compact | Taralay Initial Compact | Tarastep |
| EDUCATION | | | | | | | | | | | |
| Reception | • | | | | | | • | • | | | |
| Corridors | • | | • | | | | • | • | | | |
| Classroom | • | | • | | • | • | | • | | | |
| Dormitory room | | | | • | • | • | | | | | |
| Changing room | | | | | | | | | | | |
| Bathroom - Toilets | | | | | | | | | | | |
| Meeting - Library | | | • | | • | • | | • | | | |
| Computer room | | | • | | • | • | | | | | |
| Laboratory | • | | | | | | • | | • | • | |
| Student's residence | | | | | • | • | | | | | |
| Student's refectory | • | | • | | • | | | | | | |
| Multipurpose room - Hall | • | | • | | • | | | | | | |
| Stairs | | | | | | | | | | | • |
| INDUSTRY | | | | | | | | | | | |
| Clean room / Laboratory | • | | | | | | • | | | | |
| Changing room | • | | | | | | • | | | | |
| Computer room | | | | | | | | | | | |
| Production | • | | | | | | • | | | | |
| Stocking and Packaging areas | | | | | | | | | | | |
| Stairs | | | | | | | | | | | • |
| HOTEL - RESTAURANT | | | | | | | | | | | |
| Reception | | | | | | | | | • | • | |
| Bedroom | | | | | | • | | | | | |
| Bathroom - Toilets | | | | | | | | | | | |
| Restaurant - Bar | | | | | | | | | • | • | |
| Conference - Exhibition | • | | | | | | • | | • | • | |
| Cinema - Show - Theatre | | | • | | • | | | • | | | |
| Stairs | | | | | | | | | | | • |

- GERFLOR's recommendation
- Other possible solutions

GERFLOR SPECIFICATION

RETAIL - HOUSING - KITCHEN



| | HOMOGENEOUS FLOORINGS | | MULTILAYERED FLOORINGS | | | | | | | | Tarastep |
|-------------------------------------|---------------------------------------------------------------------------------------------------------------------------------------------------------------------|-------------------------------|-------------------------------------------------------------------------------------------------------------------------------------------------------------------------|-------------------------|---------------------------------------------------|-------------------------|-------------------------|-------------------------|-------------------------------------------------------------------------------------|-------------------------|----------|
| |   | |   | | | | | |  | | |
| | Homogeneous Flooring (Evercare™) | Homogeneous Flooring (PUR/PU) | Taralay Premium Comfort | Taralay Element Comfort | Taralay Impression Comfort Taralay Uni Comfort | Taralay Initial Comfort | Taralay Premium Compact | Taralay Element Compact | Taralay Impression Compact | Taralay Initial Compact | |
| RETAIL | | | | | | | | | | | |
| Shop | • | | | | | | • | | | | |
| Department store | | | | | | | • | | | | |
| Supermarket | | | | | | | • | | | | |
| Cafeterias | | | • | | • | | • | | | | |
| Stocking areas | | | | | | | | | | | |
| Stairs | | | | | | | | | | • | |
| HOUSING | | | | | | | | | | | |
| Dry Private room | | | | | | • | | | | | |
| Damp Private room | | | | | | • | | | | | |
| Reception area - Corridor - Landing | | | | | | • | | | | | |
| Other private home | | | | | | | | | | | |
| KITCHEN | | | | | | | | | | | |
| Collective kitchens | | | | | | | | | | | |
| Food preparation areas - Canteen | | | | | | | | | | | |

- GERFLOR's recommendation
- Other possible solutions

RETAIL - HOUSING - KITCHEN

| FAST TRACK LOOSELAY TILES | | | LUXURY VINYL TILES | | | | | | TECHNICAL SOLUTIONS | | | SAFETY FLOORING | | | | |
|---------------------------|---------|---------|--------------------|----------------------------------------|---------------------|----------------------------------------|---------------------|-----------------------------------------------------------|-------------------------|---------------|---------------|------------------------|--------------------|----------------------------------------|-------------------|-----------------------|
| Compact | | | Comfort | | | | | | Compact Compact | | | Comfort | | | | |
| Attraction® | GTI Max | GTI EL5 | Saga ² | Creation 70 Creation 70 Clic System | Creation 70 X'Press | Creation 55 Creation 55 Clic System | Creation 55 X'Press | Creation 30/ Creation 30 Lock / Creation 30 X'Press | Static Control flooring | Shower system | Wall covering | Tarasafe Ultra Comfort | Tarasafe Ultra H2O | Tarasafe Ultra / Geo / (SparClean®) | Tarasafe Standard | Tarasafe Plus / Super |
| • | | | | • | • | | | | | | | | | | | |
| • | | | | • | • | | | | | | | | | | | |
| • | • | | | | | | | | | | | | | | | |
| | • | | | • | • | | | | | | | | | | | |
| | | | | | | | | | | | | | | | | |
| | | | | | | | | • | | | | | | | | |
| | | | | | | | | • | | • | | • | • | • | • | |
| | | | | | | | | • | | • | | • | | • | | |
| | | | | | | | | | | | | | | | | • |
| | | | | | | | | | | | • | | | | | • |

INSTALLATION & MAINTENANCE

▶ INSTALLATION PROCEDURES

Please refer to our installation techniques on www.gerflor.com

▶ MAINTENANCE

Surface treatments:

Protecsol®

The original no-polish-for-life solution.

This unique UV-cured polyurethane surface treatment protects the floorcovering and eliminates the need for costly emulsion dressings throughout the life of the product.

Developed exclusively by Gerflor back in 1987, Protecsol® is a permanent, factory applied treatment which has been proven independently to reduce both the time and costs required to protect standard, resilient floorcoverings.

Gerflor is an innovative manufacturer and continuously strives through heavy investment in R&D to meet and exceed its customers expectations both in terms of product quality and in low environmental impact.

Our plants are constantly being upgraded and improved with the latest round of investments for Protecsol® concluding in 2006.



All the advantages of Protecsol®, and more!

PROTECSOL® 2 technology combines all the advantages of Protecsol®, tested and approved over 20 years ago: ease of maintenance, no need for wax and polish for life, water and detergent savings, plus two additional benefits:

1 The best stain shield

| | | |
|-------------------------------------------------------------------------------------------------------------------------------------------------------------------------------------------------------------------------------------------------------------|-------------------------------------------------------------------------------------------------------------------------------------------------------------------------------------------------|----------------------------------------------------------------------------------------------------|
| <p>Highly durable: Exclusive surface treatment applied by UV laser cross-linking provides superior durability and an even surface thickness, creating an impenetrable barrier against stains and chemicals</p> <p>Longer life expectancy.</p> | <p>BY GERFLOR GERFLOR: EVEN THICKNESS</p> | <p>OTHER TREATED FLOOR COVERING COMPETITOR: MISSING TREATMENT AND UNEVEN THICKNESS</p> |
| | <p>Water-repellent effect: The surface treatment creates a 100% non-porous barrier to prevent all liquids and chemicals from penetrating the materials, remaining on the surface</p> | <p>Simple and easy stain removal.</p> |

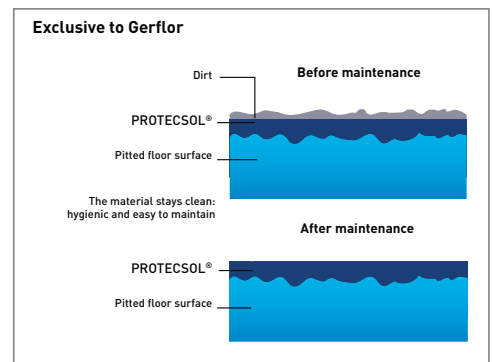

Low environmental impact

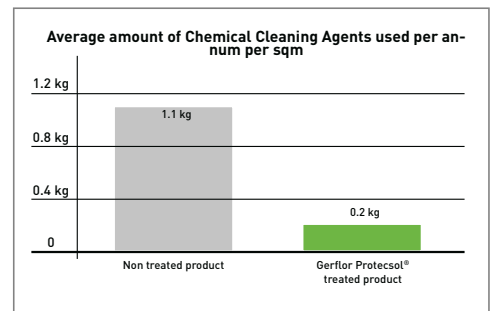

2 Matt effect for enhanced design



SparClean®

New generation of surface treatment for Tarasafe safety flooring.

SparClean® is a powder coated treatment that when heated forms a totally smooth surface between the mineral crystal particles, eliminating dirt traps and setting new standards for cleanliness and hygiene. The unique method of manufacture ensures that the slip resistance of the Tarasafe safety flooring is not impaired in any way, yet provides a safety floor that is easy to clean.

SparClean® is a permanent surface treatment that gives extreme resistance to soiling and staining, offers excellent resistance to chemicals and ensures long term product durability.

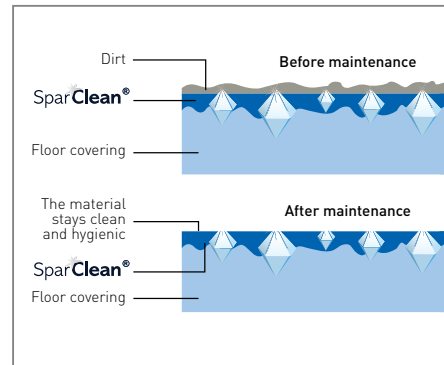

evercare™ TECHNOLOGY

An exclusive patented technology by Gerflor.

The best chemical stain resistance surface treatment

| | | |
|----------------------------------------------------------------------------------------------------------------------------------------------------------------------------------------------------------------------------------------------------------------------------------------------------------------------------------|---------------------------------------------------------|------------------------------------------------------------------------------------------------------|
| <p>Highly Durable: Exclusive surface treatment applied by UV Laser cross-linking provides superior durability and an even surface thickness, creating an impenetrable barrier against stains and chemicals found in healthcare like betadine, eosin or anti-bacterial hand gel.</p> <p>Longer life expectancy.</p> | <p>BY GERFLOR</p> <p>GERFLOR: EVEN THICKNESS</p> | <p>OTHER TREATED FLOOR COVERING</p> <p>COMPETITOR: MISSING TREATMENT AND UNEVEN THICKNESS</p> |
| <p>100% non-porous surface: The surface treatment creates a 100% non-porous barrier to all liquids and chemicals, keeping all stains floating on the surface.</p> <p>Simple and easy stain removal.</p> | | |

PUR+

Polyurethane surface treatment.

PUR+ surface treatment provides excellent cleaning characteristics and improved resistance to scratching. It significantly delays application of wax and provides excellent resistance to chemicals.

PUR

Polyurethane surface treatment.

PUR surface treatment is a good foundation for routine maintenance and avoids the immediate use of an acrylic emulsion after installation.

PU

Protective PU factory seal.

This factory coating initially applied is an installation protection and a good foundation for routine maintenance. Acrylic emulsion / polish is required after installation.



MAINTENANCE

Gerflor floorings, in common with all heavy duty floorings, require correct and regular maintenance. Whatever the manufacturing finish, satisfactory results can only be obtained by following certain basic maintenance rules.

Rubber leaves indelible stains on vinyl floorings:

- ▶ Do not use mats with rubber backing
- ▶ Replace tubular furniture feet with those made of Vinyl or polyamide (do not use rubber furniture feet and wheels). Never use solvent-based wax, seals, polishes or varnish, particularly those containing acetone and other Vinyl solvents. Place a barrier mat (which does not have a rubber backing) in doorways and entrances.
Delay maintenance until 72 hours installation for rolls and an entire week after installation for tiles.

Six types of maintenance are recommended according to the floorcovering installed:

- Very low maintenance = floorings with PROTECSOL® and PROTECSOL® 2 treatments.
- Very low maintenance for high quality homogeneous flooring = Evercare™ treatment.
- Very low maintenance for slip-resistant flooring = SparClean® treatment.
- Low maintenance = floorings with polyurethane PUR & PUR+ treatments.
- Normal maintenance for homogeneous flooring = PU treatment.
- Normal maintenance = non treated floorings.
- Specific maintenance = antistatic and conductive floorings.

▶ VERY LOW MAINTENANCE PRODUCTS

With PROTECSOL® 2 treatment: Taralay Premium, Taralay Impression, Attraction®

With PROTECSOL® treatment: Taralay Element, Taralay Uni, Taralay Initial, Saga².

With Evercare™ treatment: Mipolam Symbioz™, Mipolam Esprit, Mipolam Affinity, Mipolam Accord, Mipolam Elegance, Mipolam Cosmo, Mipolam Troplan, Mipolam Accord EL7, Mipolam Elegance EL5, GTI EL5.

With SparClean® treatment: Tarasafe Geo, Tarasafe Ultra, Tarasafe Ultra Comfort.

It is not necessary to seal the floor during its lifetime, the maintenance cost will be greatly reduced during the life of the floor.

▶ INITIAL CLEANING

Remove loose debris after the installation of floor. Wash floor with a low speed cleaning machine (150-200 rpm) fitted with a red pad. Use neutral detergent. Ensure that all detergent residues are rinsed and removed from the floor.

▶ PROTECTION

This step also known as «metallisation», «self-shine», or «polishing», is not necessary for these treated products.

▶ DAILY MAINTENANCE

Remove dirt with a damp mop and neutral detergent. Dry sweeping is also possible. Mechanical maintenance provides better aesthetic results.

▶ PERIODIC MAINTENANCE

Clean with a high speed (450 rpm) machine fitted with a red pad or nylon brush or scrubbing machine + neutral detergent.

▶ LOW MAINTENANCE PRODUCTS

With PUR treatment: Mipolam Classic, Tarasafe Standard.

With PUR+ treatment: GTI MAX, Creation 70 (DB, Clic System, X'Press), Creation 55 (DB, Clic System, X'Press), Creation 30 (DB, Lock, X'Press).

PUR and PUR+ treatments are protective polyurethane surface treatments applied to the product during the manufacturing process. Results: it is not necessary to seal the floor after installation. Protection is required when aesthetic and hygienic properties are judged inappropriate by maintenance staff. In the meantime, maintenance costs are reduced.

▶ INITIAL CLEANING

Remove loose debris after the installation of the floor. Wash floor with a low speed cleaning machine (150-200 rpm) fitted with a red pad. Use neutral detergent. Ensure that all detergent residues are rinsed and removed from the floor.

▶ PROTECTION

This step also known as «metallisation», «selfshine», or «polishing» is only necessary when aesthetic and hygienic properties are judged inappropriate by maintenance staff.

▶ DAILY MAINTENANCE

Remove dirt with a damp mop and neutral detergent or floor maintainer. Dry sweeping is also possible.

▶ PERIODIC MAINTENANCE

Clean with a high speed (450 rpm) machine fitted with a red pad, or nylon brush, or a scrubbing machine + neutral detergent, or floor maintainer.

▶ NORMAL MAINTENANCE PRODUCTS.....

With PU factory seal: Architecton.

Non treated floorings: Tarasafe Super / Plus.

▶ INITIAL CLEANING

Remove loose debris after the installation of floor. Wash and clean off with a machine fitted with blue or green pad + stripping agent at 150-200 rpm. The brown pad is suitable for removal of heavy dirt and/or grease. Ensure that all detergent residues are rinsed and removed from the floor.

▶ PROTECTION

This step is also known as "metallisation", "self-shine", or "polishing". It is usual to apply 3 coats of polish to new floors, as this will impair the slip resistance, allowing one coat to dry before applying the next coat.

⚠ Do not use this treatment with the Tarasafe products to keep their slip resistance properties.

▶ DAILY MAINTENANCE

Remove dirt with a damp mop and neutral detergent or disinfectant. Dry sweeping may be sufficient.

▶ PERIODIC MAINTENANCE

Clean with a high speed (450 rpm) machine fitted with a blue or red pad using a spray detergent or floor maintainer. For Tarasafe ranges, clean with a machine fitted with a blue or green pad (450 rpm) or a scrubbing machine + neutral detergent. Every year protection should be removed and reapplied.

▶ SPECIFIC MAINTENANCE PRODUCTS.....

Static control floorings: Mipolam Robust EL7, Mipolam Accord EL7, Mipolam Technic EL5, Mipolam Elegance EL5.

▶ INITIAL CLEANING

Remove loose debris after the installation of floor. Wash and clean off a machine fitted with blue pad + stripping agent (such as REMAT manufactured by WETROK) at 150-200 rpm. Ensure that all detergent residues are rinsed and removed from the floor. The green pad is suitable for removal of heavy dirt and/or grease.

▶ PROTECTION

This step is also known as «metallisation», «self-shine», or «polishing». Do not protect the floors in surgery rooms : only apply one coat of MEPOL HMA manufactured by WETROK or equivalent complying with electrical properties.

▶ DAILY MAINTENANCE

Damp mop and neutral detergent and disinfectant to remove dirt.

▶ PERIODIC MAINTENANCE

Clean with a high speed (450 rpm) machine fitted with a red pad or nylon brush + neutral detergent.

▶ STAIN REMOVAL TABLE.....

Blood - Urine - Faeces: Use diluted bleach and thoroughly rinse with water to remove all residues.

Vinegar - Tomato - Mustard: Add a few drops of ammonia to water, this may remove the stain.

Rust: Use either proprietary anti-rust treatment or oxalic acid (rinse thoroughly).

Heavy grease - Paint - Rubber scuffs - Hair colourings - Food fats - Ball point or felt-tip pens: Petrol. White Spirit. Scrub using an undiluted detergent, rinse thoroughly and remove all residues.

Cigarette burns: For calendered products : rub gently with a very fine grade sandpaper, or fine wirewool. Apply a self-shine emulsion over the entire surface.

▶ CLEANING & MAINTENANCE PRODUCTS.....

For the maintenance of its floorings Gerflor recommends contacting the following companies:

W & M FRANCE PROFESSIONAL SAS (wmprof.com) / **ECOLAB** (henkel-ecolab.com) / **DIVERSEY** (johnsondiversey.com)
KIEHL FRANCE (info@kiehl.fr)



GERFLOR WEB SITE

**NEW DESIGN,
NEW NAVIGATION!**

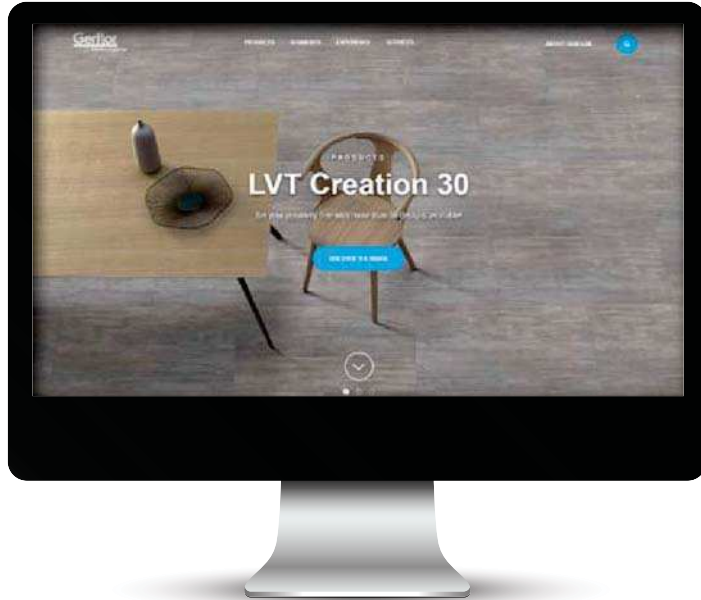

A website you can **access on your tablet or smartphone** everywhere!



Follow us on social media!

Gerflor

Be connected!



www.gerflor.com

#Gerflor

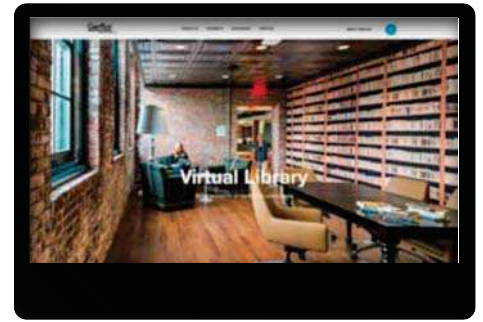

1 ON LINE VIRTUAL LIBRARY

Thanks to the **virtual library** find all types of documentation online, even the cards! You can take a look at the cards, download them or order them.

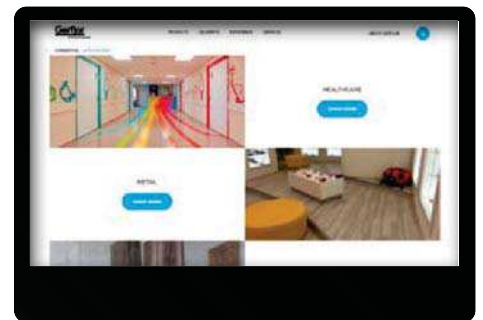

2 SECTION "SEGMENTS"

Navigate by market: find product recommendations, reference pictures and all information relating to **products!**

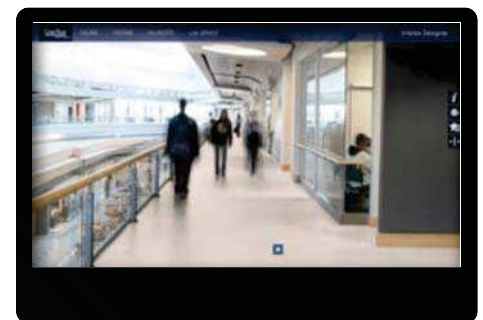

3 ROOM VISUALIZER "INTERIOR DESIGNER"

Choose a picture or upload the picture of your own project, select a Gerflor floor and visualize in few clicks the results!

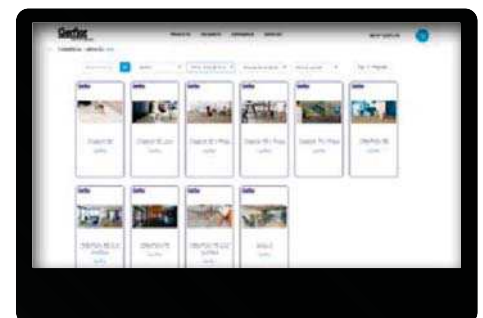

4 BIM SECTION DOWNLOAD GERFLOR BIM OBJECTS!

In this section, we offer all our flooring in IFC, REVIT & Archicad formats.

GERFLOR INTERNATIONAL
 Tel: +33 (0)4 74 05 40 00
 Fax: +33 (0)4 74 05 03 13
 e-mail: gerflorcontract@gerflor.com

gerflor.com

**ARCHITECTURE
 DECORATION
 SPORT
 TECHNOSPECIFIC**

Gerflor Don't forget our complementary ranges!



Handrails



Wall Coverings
& Protections



Entrance mats



Skirtings
& Profiles

Be connected!



www.gerflor.com

#Gerflor

GERFLOR, ECO-RESPONSIBLE SOLUTIONS



COMPOSITION
 100% REACH compliant
 FREE of formaldehyde
 FREE of heavy metals
 FREE of solvent



RECYCLED CONTENT
 25% average recycled content
 100% REACH compliant recycled content



RECYCLABILITY
 100% recyclable product



INDOOR AIR QUALITY
 TVOC emissions between 10 and 100 times better than norms requirements
 Floorscore certified
 No formaldehyde emission



INSTALLATION
 Innovative adhesive free installation systems



LCA
 - Eco-designed according to a product specific Life Cycle Analysis
 - Product specific EPD (Environmental Products Declaration) available
 - Manufactured in an Iso 14001 and Iso 50001 certified site
 - Contribution to many Green Building Schemes (LEED, HQE, BREEAM...)



WELLNESS
 Health: Antibacterial activity (inhibits growth > 99%)
 Safety: Anti slip performance
 Comfort: Walking comfort and impact noise reduction

Gerflor
 theflooringgroup