

**MITSUBISHI  
ELECTRIC**

*Changes for the Better*

**AIR CONDITIONING SYSTEMS**

for a greener tomorrow



# CITY MULTI

**CM11WD-I**

Air conditioning is an ideal way of controlling the temperature, movement and cleanliness of air inside any building, large or small. With today's buildings being so well insulated and increasingly full of electronic equipment, the need for effective climate control is greater than ever. Not only does it cool in the summer months, but air conditioning can also heat, doing away with the need for separate heating systems altogether. More and more people today are enjoying the benefits of comfortable working and living environments made possible with air conditioning.

## Our Latest Technologies

### VRF system

VRF stands for Variable Refrigerant Flow. A VRF air conditioning system modulates the flow of refrigerant depending upon the capacity requirements of the building. In its simplest form, a VRF system comprises an air-cooled outdoor unit and a series of indoor units that regulate the air temperature inside an internal space.

### Inverter driven technology

At Mitsubishi Electric we strive to continually meet the increasing demands of our customers, being the first in the industry to offer highly advanced 'inverter driven' systems. Using inverter technology our systems produce just the right amount of output to match the exact requirement of any building. These systems work so efficiently that they don't waste valuable energy by over-heating or over-cooling, resulting in greatly reduced running costs. Alternative systems that may appear cheaper, can often cost substantially more to run, making us the most cost effective choice all round.

### Intelligent Power Module (IPM) technology

The CITY MULTI range from Mitsubishi Electric provides precise control of energy input, through utilization of its Intelligent Power Module (IPM) technology. By employing this technology, highly efficient operation is possible with compact units closely matching building requirements.

### R410A refrigerant

As scientific evidence points to man-made chemicals for the damage caused to the ozone layer, we only use chlorine-free refrigerants that are safe with zero ODP (Ozone Depletion Potential). Accordingly, our systems require less energy to run, and have a significantly lower indirect global warming potential. In short, we produce the most efficient equipment possible, while helping to protect the environment.

## Unsurpassed air conditioning from Mitsubishi Electric

Known the world over, the name **Mitsubishi** is a trusted household name associated with a variety of products and services. Founded in **1920**, the company known today as **Mitsubishi Electric**, quickly rose to the forefront of the air conditioning industry - a position we still enjoy today. We pride ourselves on offering some of the most energy efficient systems available on the market.

### Contents

Features of Mitsubishi Electric air conditioners	Page 1-16
Remote Controller	Page 17-38
Indoor unit	Page 39-81
Outdoor unit	Page 82-137
Optional parts	Page 139-142



# VRF system

## Our answer to VRF

Mitsubishi Electric sets the boundaries of VRF technology with the CITY MULTI range, which is available using R410A refrigerant with zero ODP (Ozone Depletion Potential). The range has been specifically designed for today's building requirements and addresses key market issues such as energy efficiency, adaptability and reliability. With user friendly control systems utilizing internet technology and integrated cooling and ventilation indoor units, CITY MULTI is the benchmark and market leader in VRF technology.

VRF is a multi and direct expansion type air conditioning system where by one outdoor unit can be connected with multiples indoor units. The amount of refrigerant can be regulated freely according to the load on the indoor unit by the inverter driven compressor in the outdoor unit. Zoning in a small office is possible with a small capacity indoor unit. Energy conservation is easily handled because individual indoor units can stop and start their operation as needed. There are various indoor units available in order to suit various interior design needs.

Sophisticated  
yet simple technology

### Reliable

Designed and manufactured to the highest standards, the CITY MULTI range offers one of the most reliable air conditioning systems available. Simple to install and easy to maintain, this range provides ideal solutions you can trust to protect your investment.



>All the CITY MULTI outdoor units are made in Japan under stringent control.

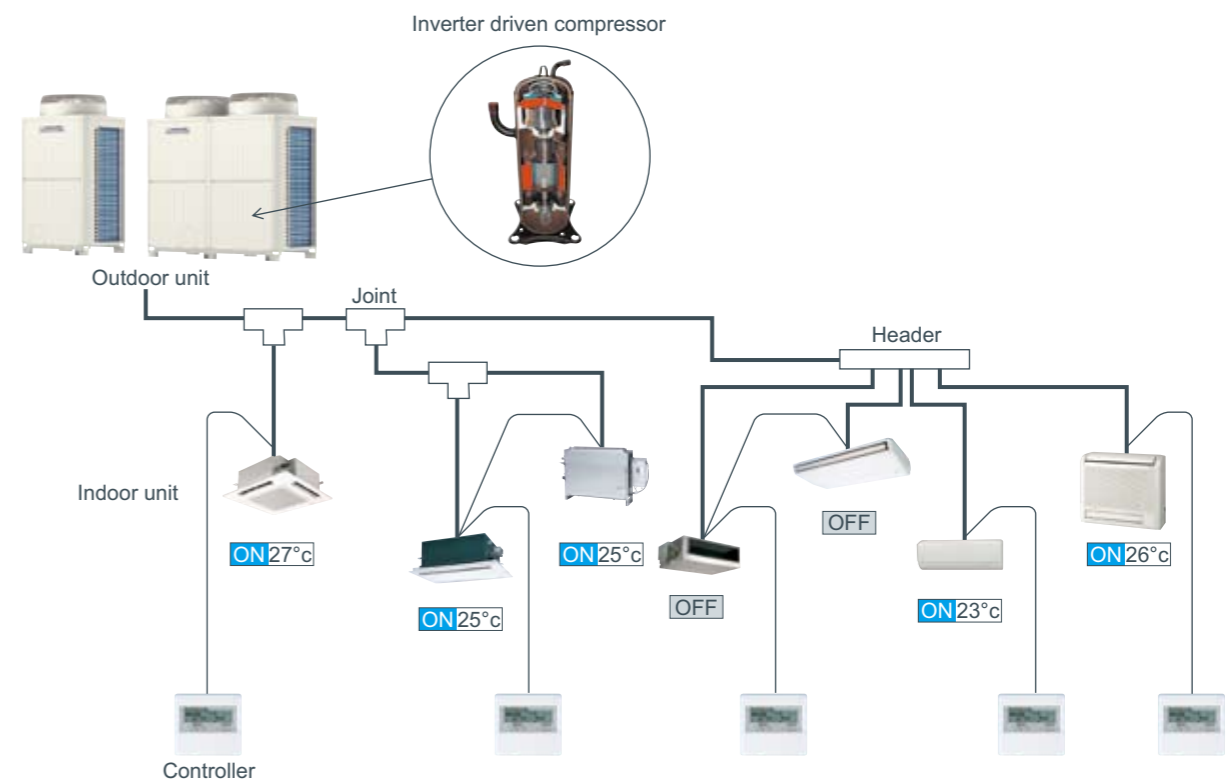



# Unbeatable Efficiency

## Heat Interchange Circuit

The unique Heat Interchange Circuit (HIC) enhances efficiency by providing additional sub-cooling and allows the expansion device to effectively control the refrigerant distribution, thereby increasing the operating efficiency and reducing the volume of refrigerant in each system.

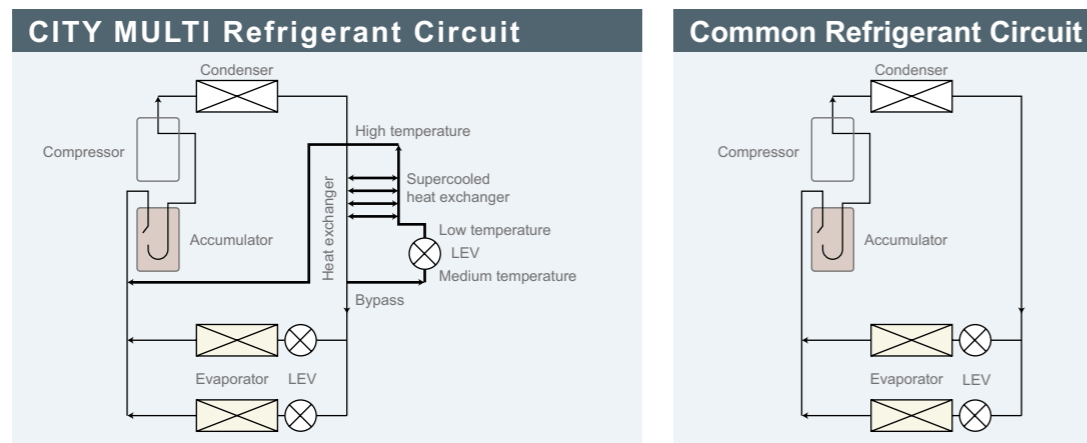

# Inverter Driven Compressor Technology - now up to 50HP



Low Starting Currents

Using inverter driven technology saves energy for several reasons:

The compressor varies its speed to match the indoor cooling or heating demand and therefore only consumes the energy that is required.

When an inverter driven system is operating at partial load, the energy efficiency of the system is significantly higher than that of a standard fixed speed, non inverter system.

The fixed speed system can only operate at 100%, however, partial load conditions prevail for the majority of the time. Therefore fixed speed systems cannot match the annual efficiencies of inverter driven systems.

Using proven single inverter driven compressor technology, the CITY MULTI range is favored by the industry for low starting currents (only 8 amps for a 16HP YJM-A outdoor unit), and smooth transition across the range of compressor frequencies.

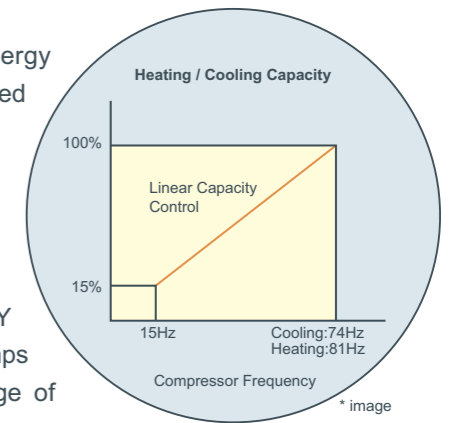

\* The values vary depending on the actual conditions such as ambient temperature.

**All CITY MULTI compressors are inverter-driven type.**  
**-Capable of precisely matching a building's cooling and heating demands.**

The outdoor unit combinations comprise 1 unit for 8-18HP systems (for Y and R2 series), 2 units for 20-36HP systems (for R2, 18-36HP) and 3 units for 38-50HP systems (Y series only). Each unit carries one inverter compressor making simple and highly reliable control possible.

Not only does it allow low starting currents, the inverter-driven compressor also provides precise indoor comfort and adapts to the air conditioning load.

## Stable and smooth operation

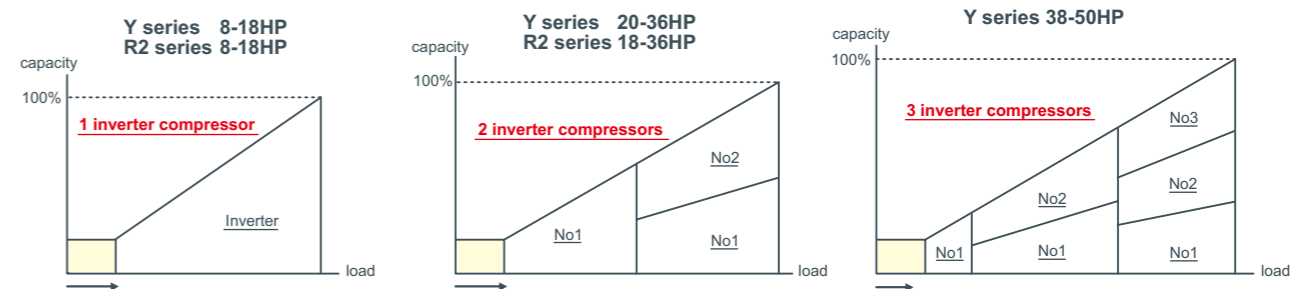



# Total Energy Conservation

## Comparison of COP (energy efficiency) – 8HP system

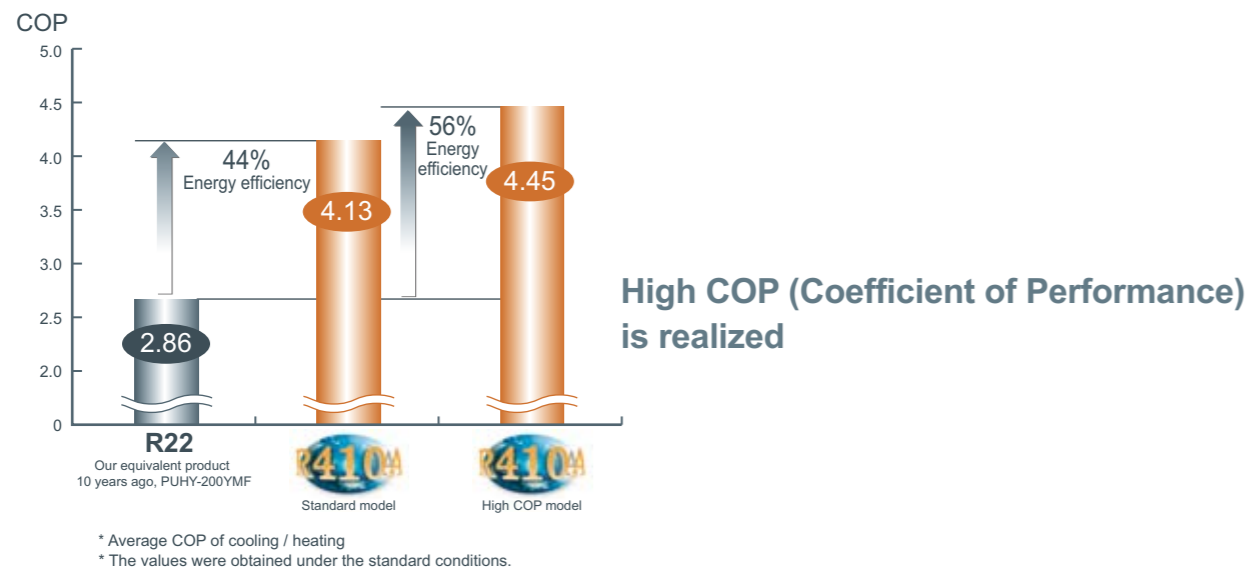

## Intelligent Power Module (IPM) Technology

The YJM-A range from Mitsubishi Electric provides precise control of energy input, through utilization of its Intelligent Power Module (IPM) technology. By employing this technology it is possible to closely match the building requirements, achieving more accurate control of the occupied space. By using incremental 1Hz steps of capacity control, the amount of power input required is significantly reduced, resulting in greatly improved COP's.

In addition, IPM technology ensures effective performance under partial load conditions, a condition that most systems will be in for the majority of the normal working life cycle. By taking account the efficiency at both part load, and peak load conditions, R410A CITY MULTI is designed to provide unbeatable year round/seasonal efficiency.

## The difference between YJM-A and previous Mitsubishi Electric models

Technology is key when increased efficiency is demanded. The CITY MULTI YJM-A range is able to deliver this in simple ways.

A highly efficient R410A scroll compressor design results in less friction losses at the motor. A simplified refrigerant circuit (low pressure loss) including a new accumulator design also adds a few more points to the efficiency scale. Enhancements to the heat interchange circuit, an inverter driven fan motor and a heat exchanger design again add vital increases to overall system efficiencies and COPs.

## The importance of COP

COP stands for "Coefficient of Performance". It is a measure of the useful energy a system can deliver compared to the energy it consumes. It is calculated by dividing the energy output by the energy input of a system. The higher the figure then the more efficient the system is deemed to be. Mitsubishi Electric VRF models, the world's highest energy-efficient air-conditioners, will undoubtedly reduce millions of tons of CO<sub>2</sub> emissions.





# For the Environment

Enhancing environmental care (measures for the RoHS Directive and the refrigerant reduction)  
Every unit is in compliance with the RoHS Directive,\* which stands for the Restriction of Hazardous Substances: Lead-free soldering is used to avoid Lead Groundwater Contamination on the print board. The amount of refrigerant on the unit has also been reduced to enhance environmental care.

\* RoHS Directive: the restriction of the use of certain hazardous substances in electrical and electronic equipment that has been sold in EU since July 2006

## Efficient R410A refrigerant



### History of refrigerant

R22, an HCFC-based refrigerant, has been a popular choice for most chillers. R22 has been targeted by the Montreal Protocol to be phased out in new equipment. Additionally, governments in many countries are enforcing a ban of HCFC-based refrigerants for new installations.

Because of these restrictions, R410A refrigerants are desirable. R410A is a blend of HFCs, which do not deplete the ozone.

### Technical aspects of refrigerant

R410A is a more efficient refrigerant as it has a higher specific heat capacity when compared to R407C or R22. This higher energy carrying capacity allows for smaller pipe sizes, longer pipe runs and reduces the volume of refrigerant within a system. This is a major factor when concerning safety and environmental requirements in the design, manufacture, installation, operation, maintenance and disposal of refrigerating systems.

### New Design

**New fan design**  
Reduction of operation noise

**New heat exchanger design**  
Improvement of COP

**New inverter compressor**  
Improvement of COP

**New Control Box design**  
Improvement of reliability and easy maintenance

Photo : Y series





# Affordable & Effective air conditioning you can rely on

By the heat recovery system, the more frequently cooling and heating simultaneous operation is carried out, the higher energy-saving effect becomes.

Operation pattern of CITY MULTI R2/WR2 System

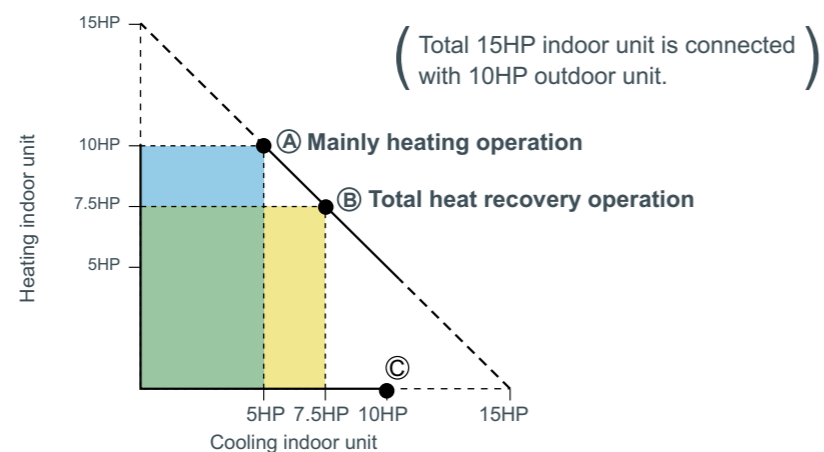

## Unique technology

**Unique to Mitsubishi Electric**, our heat recovery technology uses just two pipes, as opposed to the market conventional three. Designed for effective simultaneous heating and cooling our R2 and WR2 systems offer substantial savings on installation and annual running costs.

### Why Heat Recovery?

Flexibility and efficiency are key factors when selecting a heat recovery system. For example, while a heat pump system is adequate for a large open-plan office, an office that has a more partitioned structure will require the need to simultaneously heat or cool different sections of the office according to each user's individual preferences. The efficiency of this type of system comes from the ability to use the by-products of cooling and heating to transfer energy where it is required, thus acting as a balanced heat exchanger achieving up to 20% cost savings over a conventional heat pump system. The number of connection sites needed for a R2 / WR2 system are also significantly lower than those needed for a three pipe version. This helps to reduce installation costs, further increasing the savings associated with CITY MULTI.

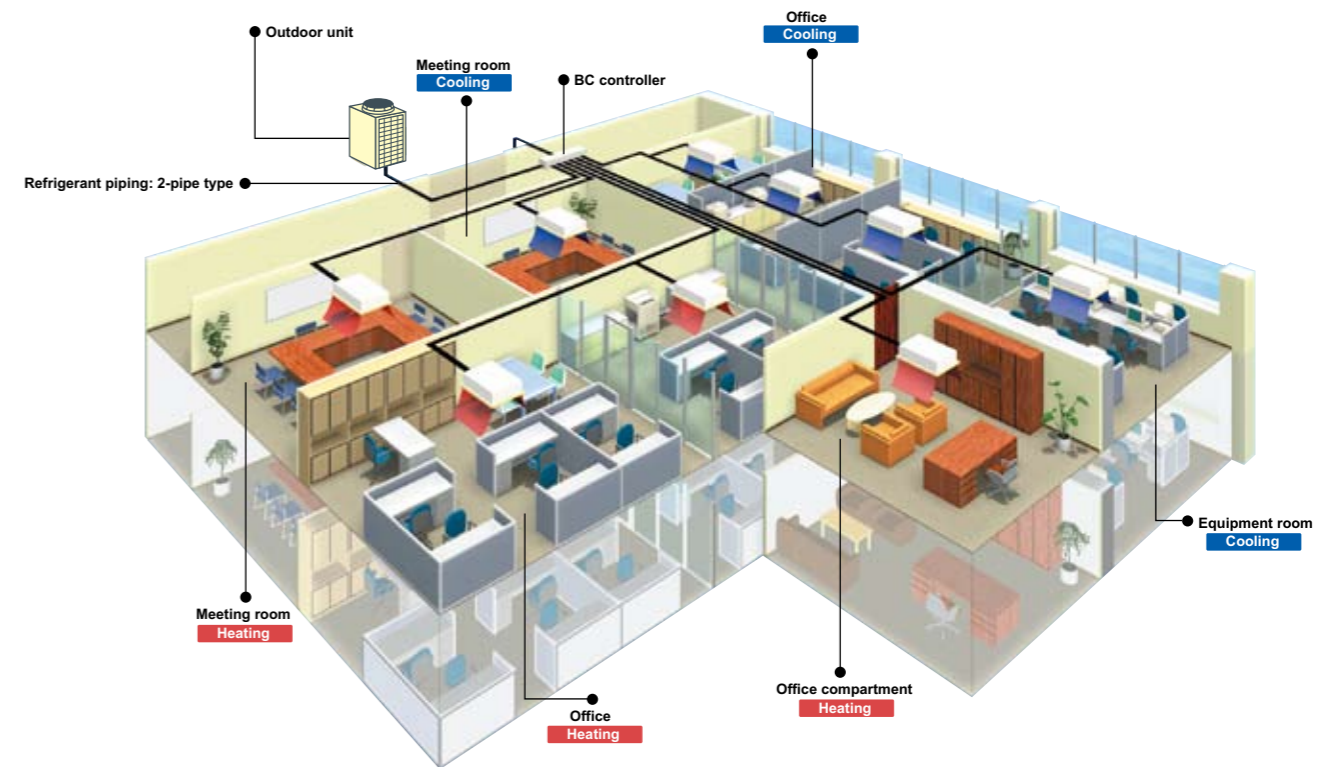



# “2-pipe” system provides Better Efficiency and Performance

## The world’s first and the only “2-pipe” system

### How does the R2/WR2 Heat Recovery System operate on 2 Pipe’s?

The secret of CITY MULTI heat recovery systems lies in the

#### BC Controller

The BC Controller houses a liquid/gas separator, allowing the outdoor unit to deliver a mixture (2 phase) of hot gas for heating and liquid for cooling, all through the same pipe. Three pipe systems allocate a pipe to each of these phases. When this mixture arrives at the BC Controller, it is separated and the correct phase delivered to each indoor unit depending on the individual requirement of either heating or cooling.

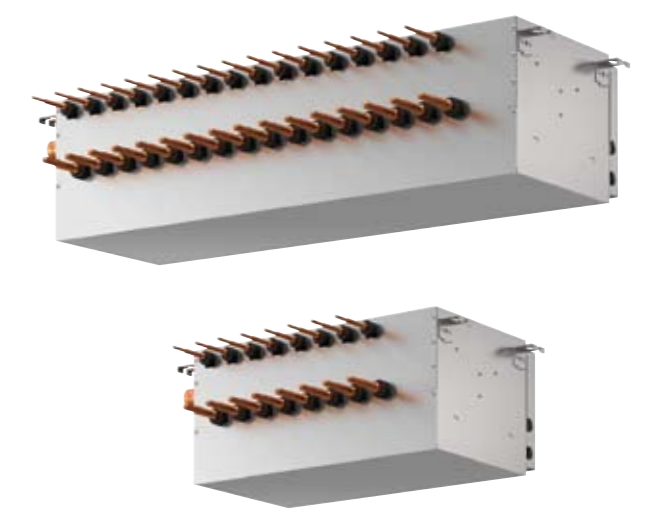

### Comparison example of piping connection sites

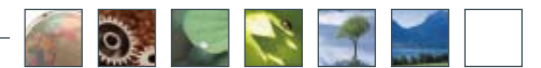
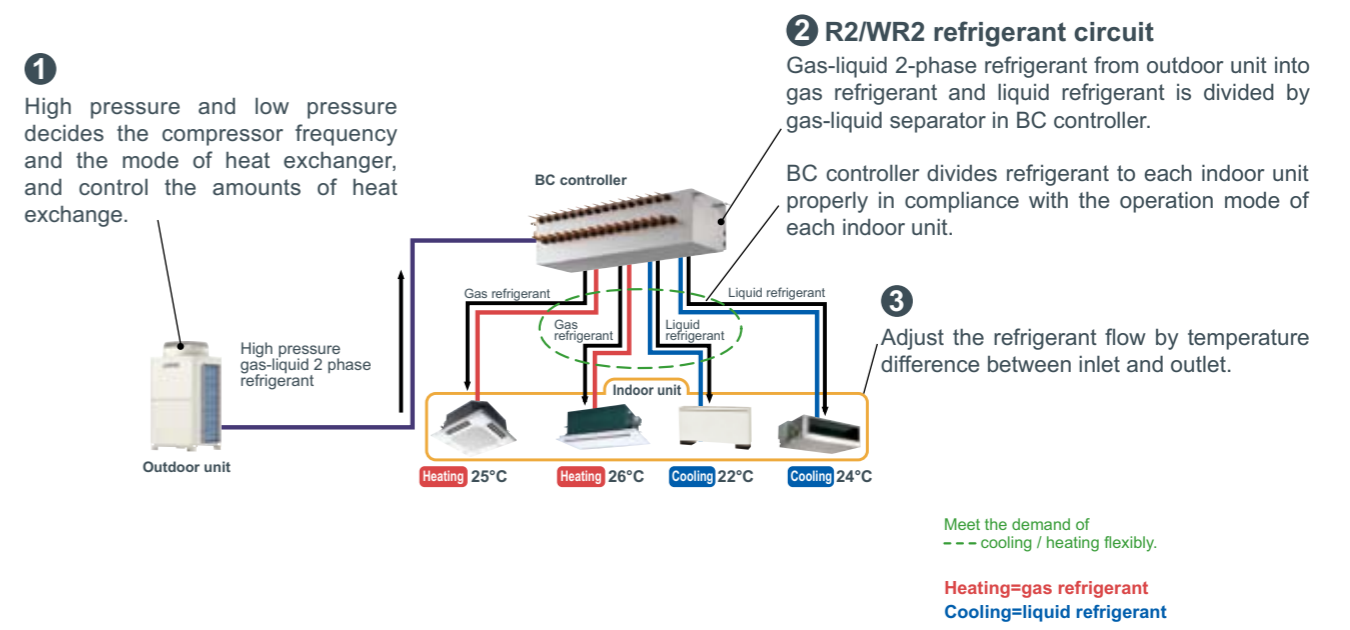
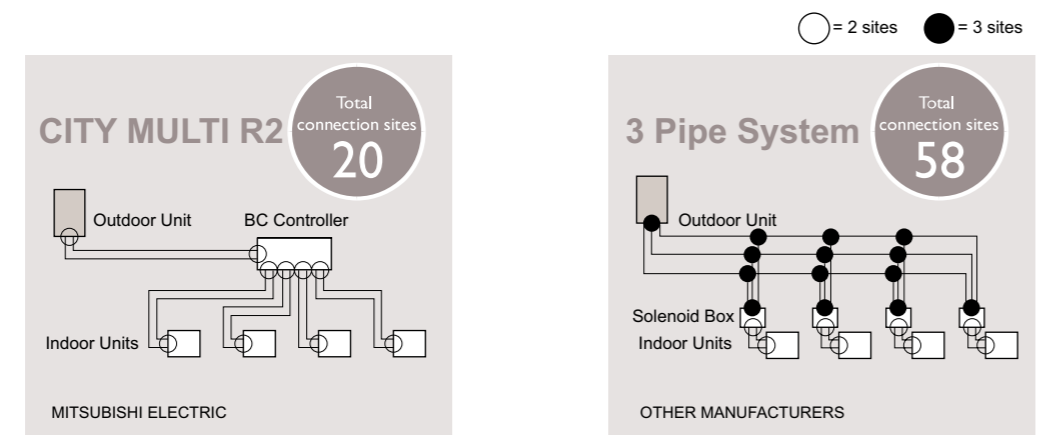



# Water Cooled CITY MULTI Benefits

Water cooled systems are ideally suited for use in temperate and cooler climates since heat exchange with the outside air is not required.



Water cooled systems can be used even in buildings that are taller than 50m by running a main water pipe through each floor.

Any heat source system that can supply heat source water between 10°C~45°C can be used.

Simultaneous heating and cooling operation is available. (WR2 series)

It is suggested that Water-Cooled systems are used in the buildings in which there are heating and cooling needs as follows.

- Buildings that require all year cooling  
Example,
  - Tenant buildings in which kitchens and offices exist together
  - Buildings in which equipment rooms and offices exist together
- Buildings in which there are large room temperature differences between sunny and unsunny rooms
- Hotels in which there are a lot of individual operation needs

# Energy Saving Technology

## What is Water-Cooled?

>A unique offering from Mitsubishi Electric

It is possible now to combine the features of VRF with a water circuit using CITY MULTI WR2/WY. In this case the heat is rejected to a water source rather than to the outside air.

The advantages of water cooled systems are that the water can be delivered at optimised temperatures and volumes, which allows even greater flexibility and increased COP.



## WR2(Heat recovery type)

Mitsubishi Electric now offers double heat recovery operation.

The first heat recovery is within the refrigerant system. Simultaneous cooling and heating operation is available with heat recovery performed between indoor units.

The second heat recovery is within the water loop, where heat recovery is performed between the PQRY units.

This double heat recovery operation substantially improves energy efficiency and makes the system the ideal solution to the requirements of modern office buildings, where some areas require cooling even in winter.

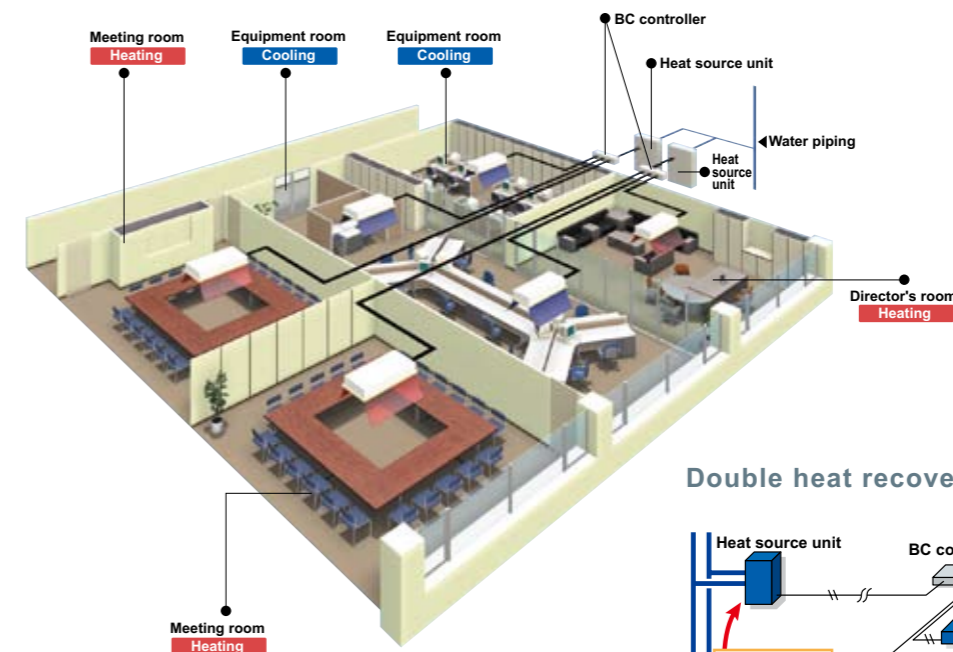

### Double heat recovery (WR2)

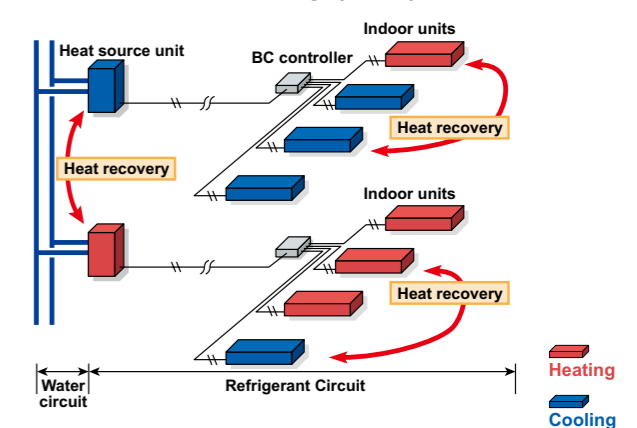



# Remote Controller

Individual Remote Controller

Centralized Remote Controller

## The importance of control

The need for control is paramount in order to optimise the performance of any air conditioning system and minimize its running costs. Mitsubishi Electric offers a wide range of control options designed to meet such needs.

Operating an air conditioning system without the right control can prove costly. It's therefore important to ensure that every system is correctly specified to the degree of control it requires. Mitsubishi Electric have a wide range of controls available 'off-the-shelf' and individual control systems can be specifically designed to match.

Good controls will benefit any application, large or small. Air conditioning products need to react to a variety of factors: different room sizes, usage and staff levels; changes in the climate; electronic equipment and lighting ...the list goes on. So whatever the application, optimum control of air conditioning systems is essential and will result in a constant, comfortable environment, which in turn is both energy and cost efficient.

### A degree of difference

When an air conditioning system is not properly controlled, it will not run as efficiently as it should. For every degree that the system deviates from the required temperature, energy costs can rise by up to 5%. Specify one of the many control options from Mitsubishi Electric to ensure air conditioning works as intended, whilst giving the optimum amount of control.

### The simpler, the better

With the array of comprehensive control systems available from Mitsubishi Electric, it becomes simple to design and install air conditioning systems. From a simple hand-held controller to a AG-150A system - you are in control.





# Individual Remote Controller

**NEW**

## Wired MA remote controller PAR-30MAA



### [Advanced Functions]

- Error information
- Timer
- Operation lock
- Temperature range restriction
- Language selection

- Backlit LCD (Liquid Crystal Display)  
Large, easy-to-see display  
Full-dot LCD display with large characters for easy viewing  
Contrast also adjustable
- Auto Return  
Function to return the set temperature to the originally preset temperature after certain amount of time  
Auto return can be set respectively for cooling operation and for heating operation.  
Time can be set to a value from 30 and 120 in 10-minute increments.
- Night Setback  
To prevent indoor dew or excessive temperature rise, this control starts heating operation when the control object group is stopped and the room temperature drops below the preset lower limit temperature. Also, this control starts cooling operation when the control object group is stopped and the room temperature rises above the preset upper limit temperature.
- Dimensions: 120(W) x 120(H) x 19(D) mm

### Example of system configuration

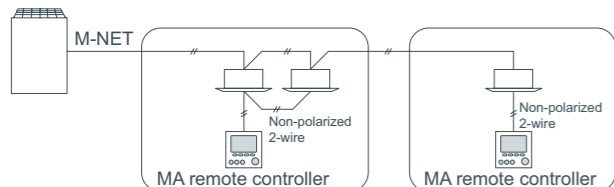

\*It's not possible to connect two 30MAA (Main/Sub) to one indoor unit.

### Heating

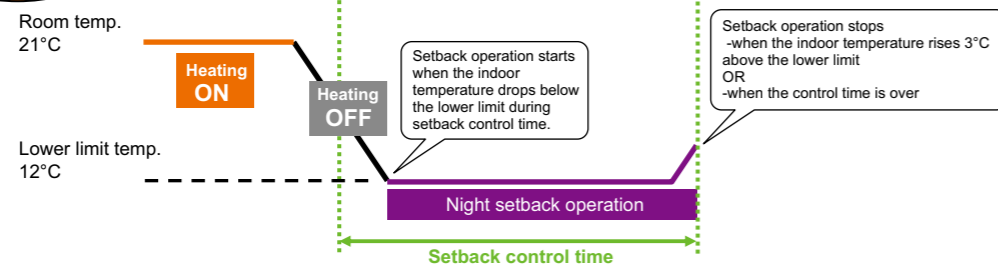

### Cooling

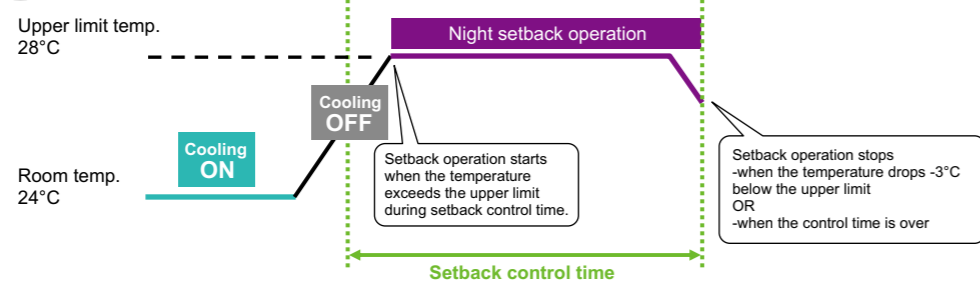

## Wired MA remote controller PAR-21MAA



### Example of system configuration

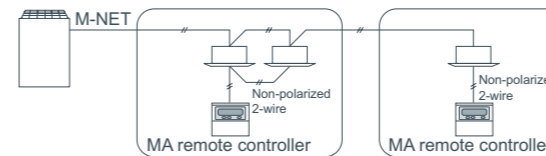

### New display-Larger, easier-to-see characters

Various information is displayed and conveyed clearly, enabling more accurate operation of the air conditioner.

### Dot Liquid Crystal Display (LCD)

The dot liquid crystal display enables quick understanding of the operation state.

### Multi-language Display

In addition to English, contents can be displayed in seven other languages.

- Dot matrix liquid crystal screen
- Set temperature in 1°C/°F increment
- Weekly timer  
Up to 8 ON/OFF/temperature setting per day in 1 minute increment. Setting kept in nonvolatile memory. No need to worry about re-setting at power failure.
- Room temperature control with thermostat sensor inside the unit
- Limit set temperature (upper/lower)
- Restrict setting changes (all changes/all except ON/OFF)
- Self-diagnosis function immediately informs error code in case of malfunction
- Dimensions: 130(W) x 120(H) x 19(D) mm  
: 5-1/8(W) x 4-23/32(H) x 3/4(D) in.

### • Display example [Operation mode]

Dot liquid crystal display

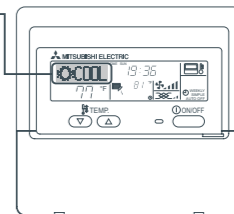

### • Display example [Cool mode]



### Multi-language Display Example [Dot display table]

Language	English	German	Spanish	Russian	Italian	Chinese	French	Japanese	
Waiting for start-up	PLEASE WAIT	←	←	←	←	←	←	←	
Operation mode	Cool	COOL	Kühlen	FRÍO	Холод	COOL	制冷	FRROID	冷房
	Dry	DRY	Trocknen	DESHUMIDIFICACIÓN	Сушка	DRY	除湿	DESHU	ドライ
	Heat	HEAT	Heizen	CALOR	Тепло	HEAT	制热	CHAUD	暖房
	Auto	AUTO	AUTO	AUTOMÁTICO	АВТО	AUTO	自动	AUTO	自動
	Auto(Cool)	COOL	Kühlen	FRÍO	Холод	COOL	制冷	FRROID	冷房
	Auto(Heat)	HEAT	Heizen	CALOR	Тепло	HEAT	制热	CHAUD	暖房
	Fan	FAN	Lüfter	VENTILACIÓN	ВЕНТ	VENTILAZIONE	送风	VENTI	送風
	Ventilation	VENTILATION	Gelüfte	VENTILACIÓN	ВЕНТИЛЯЦИЯ	AIR ESTERNA	换气	VENTI	换气
	Stand by (Hot adjust)	STAND BY	STAND BY	CALENTANDO	ОБОГРЕВАНИЕ	STAND BY	准备中	PRECHAUFFAGE	準備中
	Defrost	DEFROST	Abtauen	DESCONGELACIÓN	ОТТАВАИВАНИЕ	SBRINAMENTO	除霜中	DEGIVRAGE	霜取中
Not use button	NOT AVAILABLE	nicht verfügbar	NO DISPONIBLE	НЕ ДОСТУПНО	NON DISPONIBILE	无效按钮	NON DISPONIBILE	無効ボタン	
Check (Error)	CHECK	Prüfen	COMPROBAR	ПРОВЕРКА	CHECK	检查	CONTROLE	点検	
Test run	TEST RUN	Testbetrieb	TEST FUNCIONAMIENTO	ТЕСТОВЫЙ ЗАПУСК	TEST RUN	试运行	TEST	试运行	
Self check	SELF CHECK	Selfdiagnose	AUTO REVISIÓN	САМОАНАЛИЗ	SELF CHECK	自我诊断	AUTO CONTROLE	自己診断	
Unit function selection	FUNCTION SELECTION	Funktion auswählen	SELECCIÓN DE FUNCIÓN	ВЫБОР ФУНКЦИИ	SELEZIONE FUNZIONI	功能选择	SELECTION FONCTIONS	メニュー選択	
Setting of ventilation	SETTING OF VENTILATION	Lüfterstufen wählen	CONFIG. VENTILACIÓN	НАСТРОЙКА ВЕНТИЛЯЦИИ	IMPOSTAZIONE ARIA ESTERNA	换气设定	SELECTION VENTILATION	换气設定	

# Individual Remote Controller

## Wired ME remote controller PAR-F27MEA



- This remote control requires non-polar wiring to only one indoor unit.
- Group operation over multiple outdoor units is possible. Grouping can be changed without re-wiring, which makes dividing rooms for tenants easier.
- **Timer operation**
  - \*Daily timer operation of one ON/OFF setting everyday
  - \*Auto-off timer : 0:30, 1:00, 1:30, 2:00...4:00
  - \*The setting is kept in nonvolatile memory.
- **Function lock**
  - All functions or all functions except ON / OFF can be selected.
- **Set temperature range limit**
- **Interlock setting and operation of LOSSNAY**
- Dimensions:130(W) x 120(H) x 19(D) mm  
:5-1/8(W) x 4-23/32(H) x 3/4(D) in.
- LCD temperature setting and display in 1°F increments.

Example of system configuration

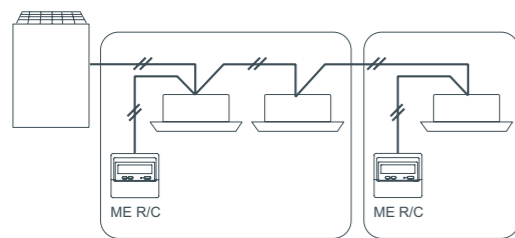

## Simple remote controller PAC-YT51CRB (MA)

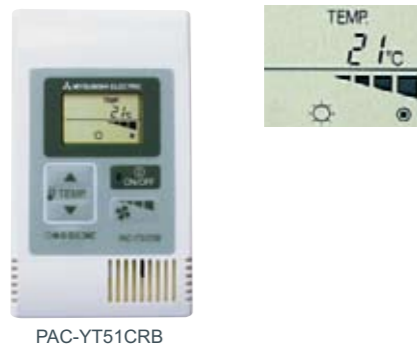

- **Control: START/STOP, room temperature, fan speed, and operation mode**
- The only wiring required is cross-over wiring based on two-wire signal lines.
- Room temperature sensors are built-in.
- LCD temperature setting and display in 1°C /1°F increments.
- **Set temperature range limit**
- **Can operate all types of indoor units**
  - \*Since this controller has limited functions, it should always be used in conjunction with standard controller or centralized controller.
- Dimensions:70(W) x 120(H) x 41(D) mm  
:2-3/4(W) x 4-23/32(H) x 1-5/8(D) in.

Example of system configuration

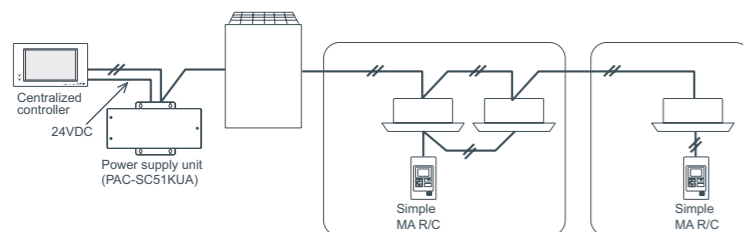

## Wireless remote controller PAR-FL32MA / PAR-FA32MA



Example of system configuration

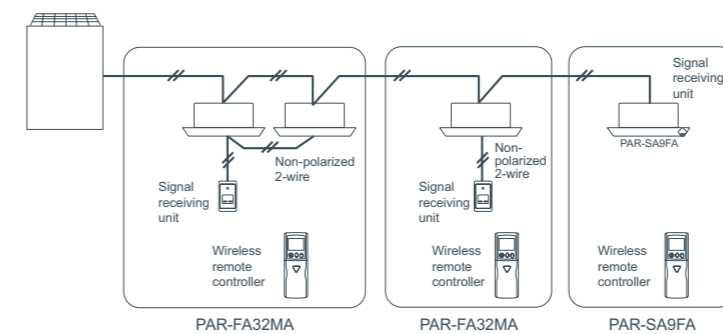

- No need to configure addresses for group operation.
- Lit LED keeps you informed of operation - blinking even gives you the error code via the number of blinks.
- Can be used with the MA remote controller.
  - \*When used in group configurations, wiring between indoor units is required.
  - \*Combining ME remote controller and/or LOSSNAY remote controller in a group is not possible.
- LCD temperature setting and display in 1°C /1°F increments.
- Dimensions:58(W) x 159(H) x 19(D) mm  
:2-5/16(W) x 6-5/16(H) x 3/4(D) in.

Correspondence table

	receiver	transmitter	
PMFY-P VBM	PAR-FA32MA	PAR-FL32MA	
PLFY-P VCM/ VLMD			
PCFY-P VKM			
PFFY-P VKM			
PEFY-P VMR-E-L/R/ VMH			
PFFY-P VLEM/VKM/VLRM/VLRMM			
PEFY-P VMS1(L)			
PEFY-VMA(L)			
PLFY-P VBM-E			PAR-SA9FA-E
PKFY-P VBM-E			Built-in
PKFY-P VHM/VKM			

# Advanced Touch Controller

With our new Advanced Touch Controller AT-50A, easy and simple operation on the touch panel offers an optimal air environment for individual unit.

## Touch controller AT-50A NEW



Dimensions: 180(W) x 120(H) x 30(D) mm  
: 7-2/16(W) x 4-12/16(H) x 1-3/16(D) in.

### System structure

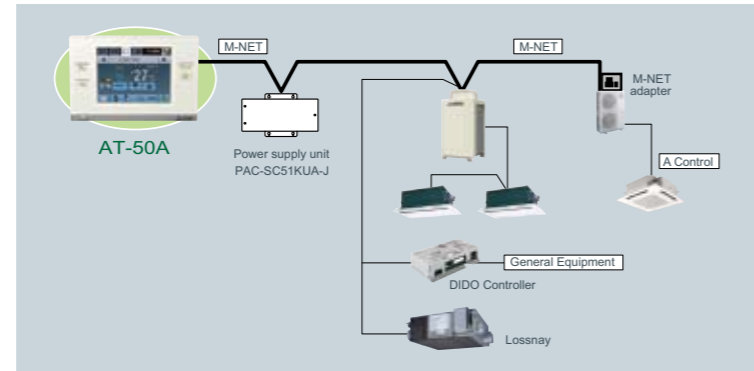

### New Design

#### Backlit LCD (Liquid Crystal Display) Touch Panel

5-inch color LCD touch panel enables easy and simple operation. The backlight lights up when the panel is touched, and lights off after certain period of time. The touch panel displays the operation status of the units in GRID, LIST or in GROUP.



**GRID (zoom-out) screen**  
Displays the operation status of all groups.



**GRID (zoom-in) screen**  
Displays the detailed operation status of each group.

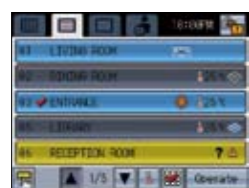

**LIST screen**  
Displays the detailed operation status of each group with group name.



**GROUP screen**  
Displays the detailed operation status of each group. Sets group operations.

### New Functions

#### Three in One

- The following three features are integrated into AT-50A.
- Control up to 50 indoor units from one location
  - A weekly programmable timer, being able to control up to 50 indoor units
  - Control up to 50 units/50 groups of air conditioners

#### Weekly and daily schedule

5 patterns of one day and 12 patterns of weekly schedule (16 settings max. per pattern). Two types of weekly schedule can be set.

#### System changeover

Operation mode can be switched depending on indoor temperature setting and target temperature of each group or a representative indoor unit.

#### Night setback function

This function allows having a two-temperature setting to keep the desired room temperature when the units are not in operation and during the time this function is effective. The unit automatically starts heating (cooling) operation when the temperature drops below (rises above) the preset lower (upper) limit temperature. This is not only for comfort environment, but also for saving energy.

#### Main system controller/Sub system controller

AT-50A can be set to Sub System controller. When connecting multiple system controllers, designate the system controller with many functions as the "Main", and set the system controllers with few functions as the "Sub".

#### Simple button arrangement

The F1 (Function 1) and the F2 (Function 2) button can be set as a run button of the following collective operation. (Setback/Schedule/Operation Mode/Temperature Correction/Remote Controller Prohibition)

### Functions

#### [Basic Functions]

- ON/OFF    Operation mode switching
- Temperature setting    Fan speed setting
- Airflow direction setting    Louver setting

### Advanced Functions

Item	Description	Operations	Display
Permit / Prohibit	The ON/OFF, operation mode, setting temperature and filter sign reset operations using the local remote controllers can be prohibited. Only ON/OFF and filter reset can be prohibited for the LOSSNAY group.	○	○
Operation lock	The operation lock can be set to the input operation of AT-50A. Each button can be set. (Function Button 1, Function Button 2, Collective ON/OFF, Touch Panel) Each function can be set. (Operation mode, Setting temperature, Fan speed, Menu button) The password for the lock release can be set.	○	○
Error display	When an error is currently occurring on an air conditioner unit, the afflicted unit and the error code are displayed. * When an error occurs, the "ON/OFF" LED flashes. The operation monitor screen show abnormal icon over the unit. The error monitor screen shows the abnormal unit address and error code. The error log monitor screen shows the time and date, the abnormal unit address, error code and source of detection.	×	□○
Ventilation (independent)	Switches the mode "Bypass/Heat recovery/Auto" for LOSSNAY groups.	○	○
Ventilation (interlocked)	The LOSSNAY will run in interlock with the operation of indoor unit. The mode cannot be changed. The LED will turn ON during operation after interlocking.	○	○
Temperature-set limitation	Batch-setting to temperature range limit at cooling, heating, and auto mode. This function cannot be used with the MA remote controller. (Depends on the indoor unit model.)	○	○
Specific mode operation prohibit (Cooling prohibit, heating prohibit, cooling/heating prohibit)	When set as the main controller, operation of the following modes with the local remote controllers can be prohibited. When cooling is prohibited: Cooling, dry, automatic can not be chosen. When heating is prohibited: Heating, automatic can not be chosen. When cooling/heating is prohibited: Cooling, dry, heating, automatic can not be chosen.	○	○
External input (Emergency stop input, etc.)	The following input with level signals or pulse signals are available. Level signal: "Emergency stop input" or "Collective ON/OFF" Pulse signal: "Collective ON/OFF" or "Local remote controller prohibit/permit" One input can be selected from those above. * An external input/output adapter (PAC-YT41HAA (sold separately)) is required. Relays and DC power supply or other devices must be prepared at the site.	○	○
External output (Error output, operation output)	"ON/OFF" and "error/normal" are output with the level signal. * An external input/output adapter (PAC-YT41HAA (sold separately)) is required. Relays and DC power supply or other devices must be prepared at the site.	○	○
Checking the Gas Amount	Use this function to check for refrigerant leak from the outdoor unit. * When this function is used, the gas amount checking function of the outdoor unit cannot be used. This function is for CITY MULTI R2 and Y (PUMY) is excluded.) series only.	□	□
Schedule operation	Weekly schedule setting up to 12 pattern is available. In one pattern, up to 16 setting of "ON/OFF", "Operation mode", "Set Temperature", "Fan speed", "Air flow direction" and "Permit / Prohibit local operation" can be scheduled. Two types of weekly schedule(Summer/Winter) can be set. Today's schedule setting up to 5 pattern in available.	○	○

\* Depending on the installation conditions, power supply unit (PAC-SC51KUA) is required. Please contact your local distributor or MITSUBISHI ELECTRIC branch office for further information.

# Centralized Remote Controller

One system controller can control up to fifty indoor units from one location. The PAC-SF44SRA also has hardwired connection available (On/Off input, fire alarm input, run output, fault output).

## System remote controller PAC-SF44SRA



- The group setting is kept in nonvolatile memory. No need to worry about re-setting at power failure.
- No individual AC power supply is needed. The power can be supplied from one outdoor unit (R410A) or Power supply unit.

System Controller			
FUNCTION	DESCRIPTION	PAC-SF44SRA	
UNITS	Max No.Units	50 units/50 group	
		Operation	Displays
ON/OFF	Run and stop operation	✓	✓
MODE SELECTION	Switches between Cool/Dry/Auto/Fan/Heat. Operation Mode will vary depending on the indoor unit. Auto mode is available with only R2 and WR2 systems	✓	✓
TEMPERATURE SETTING	Sets the groups temperature control. Values in parentheses are for the medium-temperature indoor unit. Cool/Dry:19-30°C [14-30°C] / 67-87°F [57-87°F] Heat :17-28°C [17-28°C] / 63-83°F [63-83°F] Auto :19-28°C [17-28°C] / 67-83°F [63-83°F]	✓	✓
FAN SPEED SETTINGS	Models with 4 air flow speed settings: Hi/Mid-2/Mid-1/Low Models with 3 air flow speed settings: Hi/Mid/Low Models with 2 air flow speed settings: Hi/Low Fan speed setting (including Auto) varies depending on the model.	✓	✓
AIR FLOW DIRECTION SETTING	Air flow angles: 4-angle or 5-angle, Swing, Auto, Louver ON/OFF	✓	✓
PERMIT/PROHIBIT FUNCTION	Run/Stop, Temperature Setting, Mode Selection and Filter Reset functions can be prohibited.	✓	✓
ERROR INDICATION	Displays a 4 digit code and the affected unit address	-	✓
VENTILATION INTERLOCK	Allows the group to be interlocked with a heat recovery Lossnay unit	✓	✓
EXTERNAL INPUT	On/Off/Fire Alarm	✓	-
EXTERNAL OUTPUT	On/Off/Faults	-	✓

• Dimensions:130(W) x 120(H) x 19(D) mm  
:5-1/8(W) x 4-23/32(H) x 3/4(D) in.

### System example

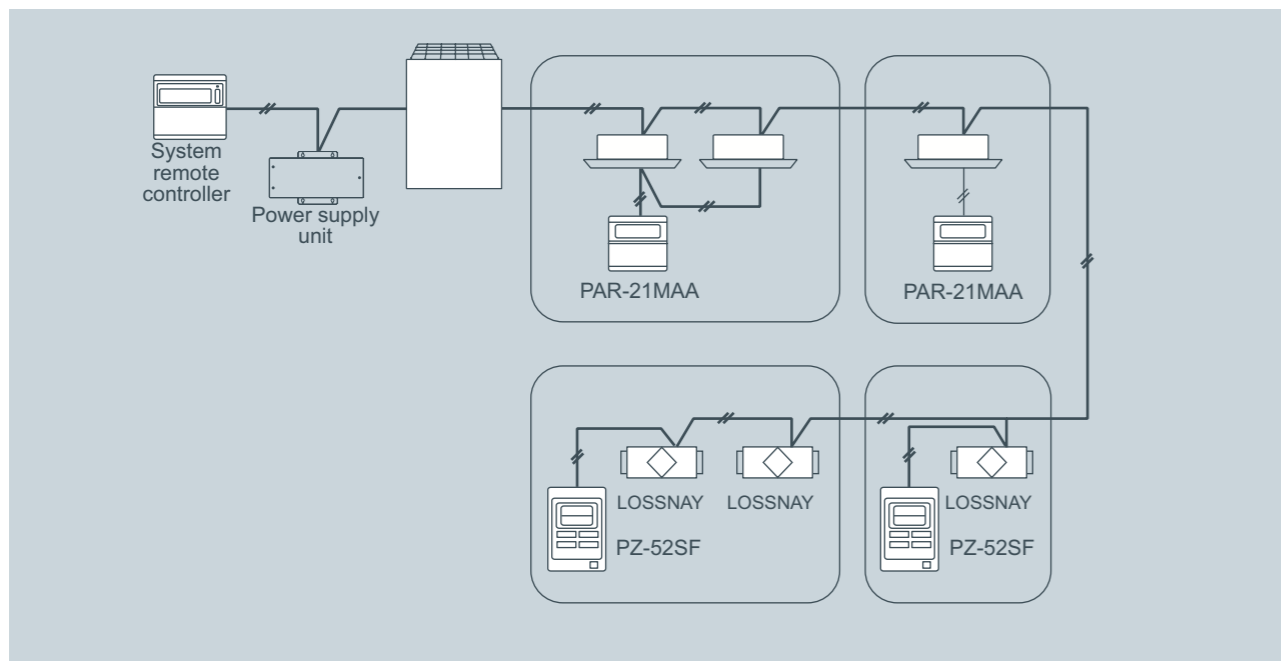

Mitsubishi Electric controllers are complimented by a weekly programmable timer, being able to control up to fifty indoor units. The PAC-YT34STA also has hardwired connection available (On/Off input, fire alarm input, run output, fault output).

## Schedule timer PAC-YT34STA



- The schedule group setting is kept in nonvolatile memory. No need to worry about re-setting at power failure.
- No individual AC power supply is needed. The power can be supplied from one outdoor unit (R410A) or Power supply unit.

Programmable Timer				
FUNCTION	DESCRIPTION	PAC-YT34STA		
UNITS	Max No.Units	50 units/50 group		
		Operation	Displays	
ON/OFF	Run and stop operation	✓	✓	
SCHEDULE FUNCTION	Content	On/Off Mode:Cool/Heat/Auto Set temperature:19°C to 28°C [67°F to 83°F] Operation Prohibit: On/Off, Mode, Set temperature	✓	✓
	Number	Weekly timer for each group 9 setting patterns + no setting 16 operations per day	✓	✓
	Unit	5 minutes	-	-
CURRENT TIME	Set the time	✓	✓	
ERROR INDICATION	Displays a 4 digit code and the affected unit address	-	✓	
EXTERNAL INPUT	On/Off/Fire Alarm	✓	-	
EXTERNAL OUTPUT	On/Off/Faults	-	✓	

• Dimensions:130(W) x 120(H) x 19(D) mm  
:5-1/8(W) x 4-23/32(H) x 3/4(D) in.

### System example

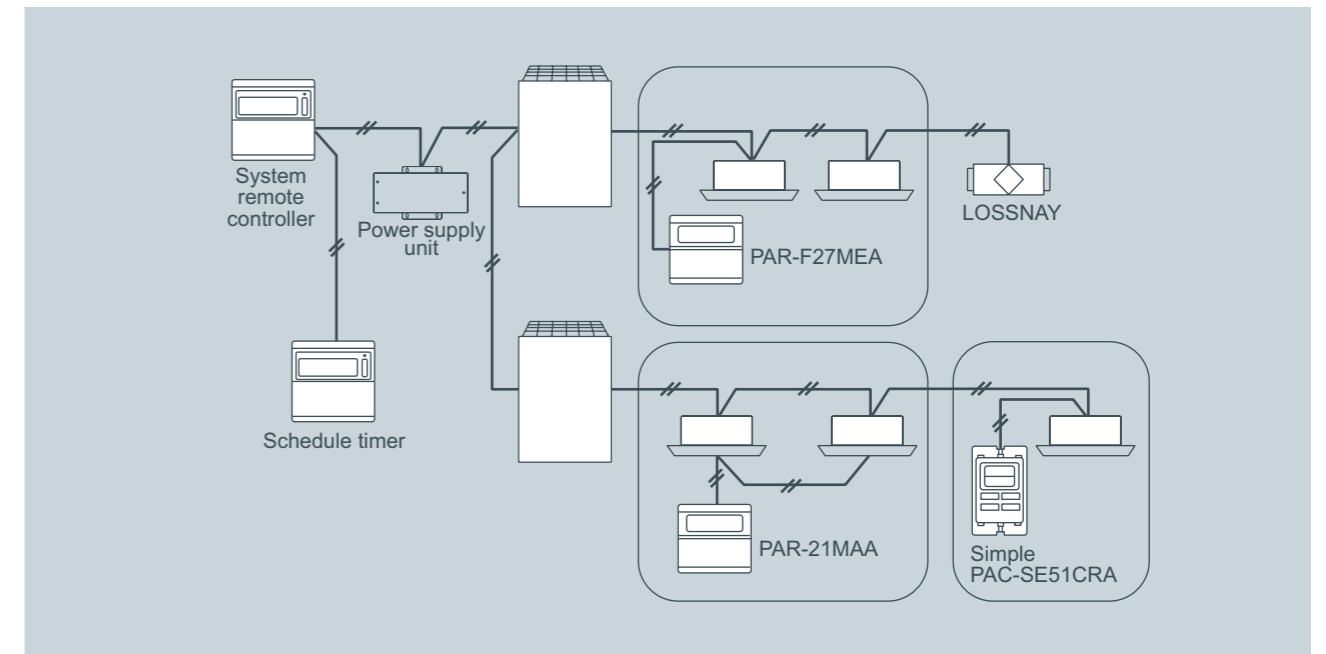

# Centralized Remote Controller

Just press a switch to start. All of the units can be On/Off by pressing the main switch, and each unit in the group can be On/Off with individual switch. The PAC-YT40ANRA also has hardwired connection available (On/Off input, fire alarm input, run output, fault output).

## ON/OFF remote controller PAC-YT40ANRA



FUNCTION	DESCRIPTION	PAC-YT40ANRA	
		OPERATIONS	DISPLAY
UNITS	Max No.Units	50 units/16 groups	
ON/OFF	Run and stop operation	✓	✓
ERROR INDICATION	LED flashes during failure. (The error code can be confirmed by removing the cover.)	-	✓
VENTILATION OPERATION (INDEPENDENT)	Group operation of only LOSSNAY units possible. *Only ON/OFF of group.	✓	✓
VENTILATION OPERATION (INTERLOCKED)	The LOSSNAY will run in interlock with the operation of indoor unit. *The fan rate and mode cannot be changed. The LED will turn ON only during operation after interlocking.	✓	✓
EXTERNAL INPUT	On/Off/Fire Alarm	✓	-
EXTERNAL OUTPUT	On/Off/Faults	-	✓

• Dimensions:130(W) x 120(H) x 19(D) mm  
:5-1/8(W) x 4-23/32(H) x 3/4(D) in.

- The group setting is kept in nonvolatile memory. No need to worry about re-setting at power failure.
- No individual AC power supply is needed. The power can be supplied from one outdoor unit (R410A) or Power supply unit.

### System example

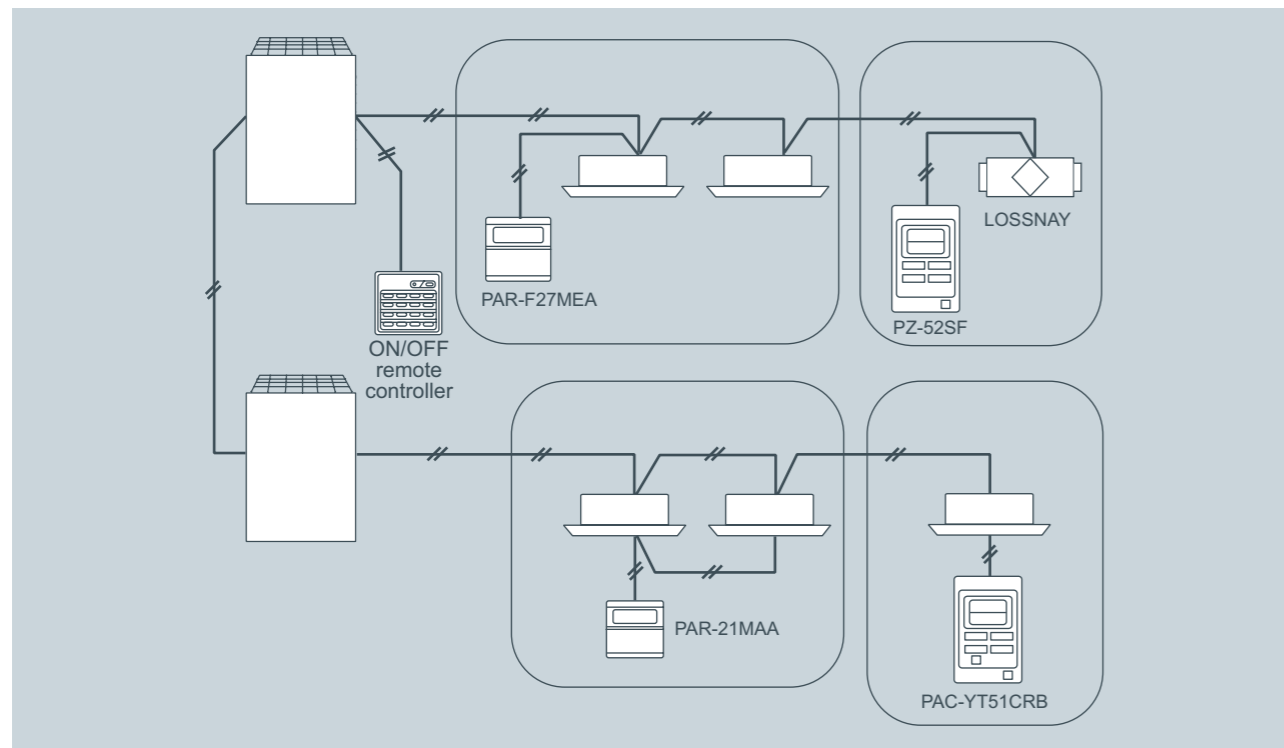

Up to 8 groups can be operated (maximum of 16 units). Just by pressing PAC-SC30GRA switches, groups can be On/Off as a batch. Suitable for small office and residential project.

## Group remote controller PAC-SC30GRA



FUNCTION	DESCRIPTION	PAC-SC30GRA	
		OPERATIONS	DISPLAY
UNITS	Max No.Units	16 units / 8 groups	
ON/OFF	Run and stop operation	✓	✓
MODE SELECTION	Switches between Cool/Dry/Auto/Fan/Heat. Operation Mode will vary depending on the indoor unit. Auto mode is available with only R2 and WR2 systems	✓	✓
TEMPERATURE SETTING	Sets the groups temperature control. Cool/Dry:19-30°C Heat:17-28°C Auto:19-28°C	✓	✓
FAN SPEED SETTINGS	4 speed – Hi-Mid2-Mid1-Low, Auto 3 speed – Hi-Mid-Low, Auto 2 speed – Hi-Low	✓	✓
AIR FLOW DIRECTION SETTING	Air flow angles: 4-angle or 5-angle, Swing, Auto, Louver ON/OFF	✓	✓
PERMIT/PROHIBIT FUNCTION	Run/Stop, Temperature Setting, Mode Selection and Filter Reset functions can be prohibited via main system controller	-	✓
INDOOR RETURN AIR TEMPERATURE	Measures the intake temperature of the master unit within the group	-	✓
ERROR INDICATION	Displays a 4 digit code and the affected unit address	-	✓
VENTILATION INTERLOCK	Allows the group to be interlocked with a heat recovery Lossnay unit	✓	✓

• Dimensions:130(W) x 120(H) x 19(D) mm  
:5-1/8(W) x 4-23/32(H) x 3/4(D) in.

### System example

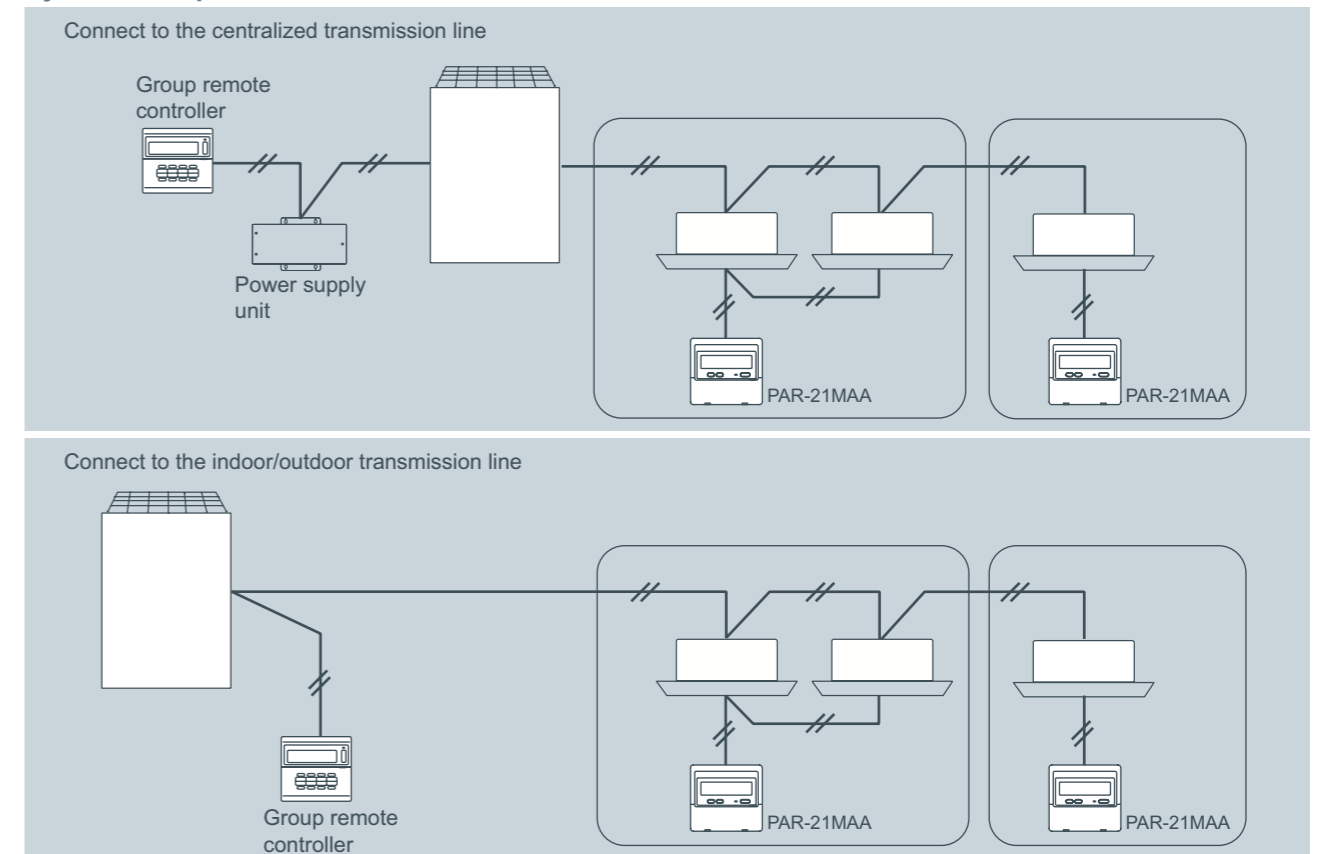

# Centralized Remote Controller

With a new colored touch panel, and continuation of all the G-50A functions, AG-150A visualizes its functions from basic control to advanced operations and bringing an ultimate controller to reality.

## Centralized controller AG-150A



Dimensions: 300(W) x 185(H) x 70.3(D) mm  
: 11-13/16(W) x 7-5/16(H) x 2-13/16(D) in.



Option : Black surface cover PAC-YG71CBL

### System structure

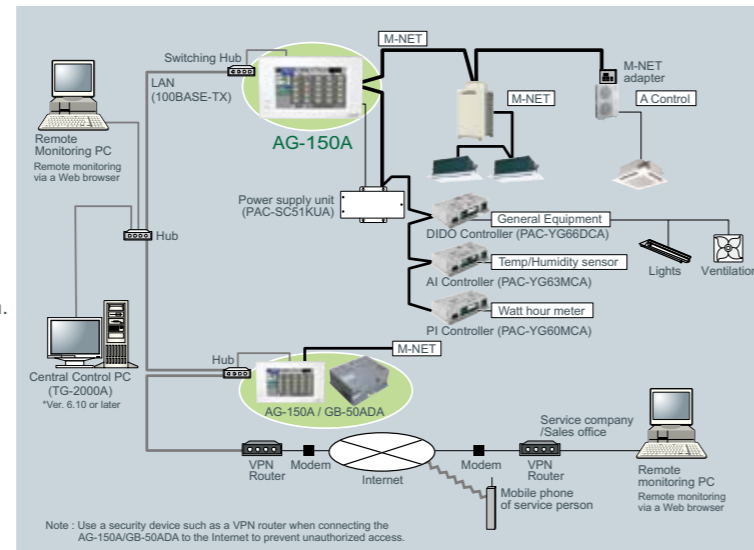

Note : Use a security device such as a VPN router when connecting the AG-150A/GB-50ADA to the Internet to prevent unauthorized access.

## Expansion Controller PAC-YG50ECA



Dimensions: 250(W) x 217(H) x 97.2(D) mm  
: 9-7/8(W) x 8-9/16(H) x 3-7/8(D) in.

With a connection of a Expansion Controller, maximum of 150 units/groups can be connected to AG-150A.

### System structure

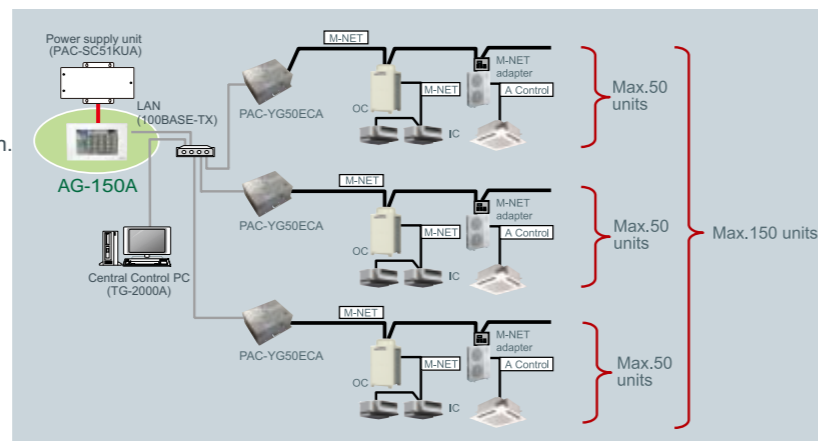

\*Do not connect PAC-YG50ECA to TB3 of the outdoor unit.

\*Use a security device such as a VPN router when connecting the AG-150A etc. to the Internet to prevent unauthorized access.

## New Design

### Backlight color liquid crystal

Backlight makes it easy to see and control units.  
One can identify whether a unit is ON or OFF from a distance.  
Control in the night with no lights is possible.

### Touch panel

9 inch wide, high-resolution  
Touch panel enables operation of units by touching with index finger.  
When object unit is touched, orange box appears around the unit icon indicating the unit selected.

### Flat back

Easy installation  
Allows for an installation of the unit either directly to the wall surface or using the installation hole in the wall.

### USB memory compatible

All measurement/initial setting CSV data extractable with USB memory.  
Can save and overwrite setting data.

## New Functions

### Controllable units/groups

Controls up to 50 units/groups (including indoor units, LOSSNAY, DIDO/AI/PI controller)  
Up to 150 units can be controlled via expansion controller; PAC-YG50ECA (AG-150A software needs to be upgraded)

### Monitoring functions

Temperature/Humidity (using AI controller with WEB browser) \*1  
General equipment such as lights on LCD (using DIDO controller)  
Interlock function from AI controller, DIDO controller to indoor units and between DIDO units are available.  
AG-150A interlock with DIDO controller or free contact on an indoor unit available. \* Ver. 2.30 or later

### Energy saving functions

Seasonal scheduling and automatic switch over \*1  
Yearly scheduling on LCD \*1  
Scheduling fan speed and airflow direction  
Optimized Start up \*1  
External temperature interlock control \*1  
Night setback control \*1  
\*1 License required.

## Functions

Item	Description	Operations	Display
Controllable unit	50 units/groups or 150 units/groups via expansion controller; PAC-YG50ECA.		
ON/OFF	Run and stop operation for the air conditioner units and general equipment. (To operate general equipment, PAC-YG66DCA is required.)	○ ○ △ ●	○ ○
Operation mode switching	Switches between Cool / Dry / Auto / Fan / Heat. (Group of LOSSNAY unit : automatic ventilation/ vent - heat interchange/ normal ventilation) depending on the air conditioner unit. Auto mode is for CITY MULTI R2 and WR2 series only.	○ ○ △ ●	○
Temperature setting	Cool/Dry : 19°C (67°F) - 30°C (87°F) [14°C (57°F) - 30°C (87°F)] Heat : 17°C (63°F) - 28°C (83°F) [17°C (63°F) - 28°C (83°F)] Auto : 19°C (67°F) - 28°C (83°F) [17°C (63°F) - 28°C (83°F)] [ ] in case of using middle-temperature on PDFY, PEFY-VML/VMR/VMS/VMH-by setting DipSW7-1 to ON. Yet, PEFY-P-VMH-E-F is excluded.	○ ○ △ ●	○
Fan speed setting	Models with 4 air flow speed settings: Hi/Mid-2/Mid-1/Low Models with 3 air flow speed settings: Hi/Mid/Low Models with 2 air flow speed settings: Hi/Low Fan speed setting (including Auto) varies depending on the model.	○ ○ △ ●	○
Air flow direction setting	Air flow direction angles, 4-angle or 5-angle Swing, Auto (Louver cannot be set)	○ ○ △ ●	○
Schedule operation	Weekly schedule can be set by groups based on daily operation pattern.	○ ○ △ ●	○
Permit / Prohibit local operation	Individually prohibit operation of each local remote control function (Start/Stop, Change operation mode, Set temperature, Reset filter).	○ ○ △ ●	○
Indoor unit intake temperature	Measures the intake temperature of the indoor unit only when the indoor unit is operating.	×	○
Error	When an error is currently occurring on an air conditioner unit, the afflicted unit and the error code are displayed.	×	□ ○
Test run	This operates air conditioner units in test run mode.	○ ○ △ ●	○
Ventilation interlock	The ventilation unit (LOSSNAY) is able to automatically start its operation when operation of the interlocked indoor unit starts.	○ ○ △ ●	○
External input/output	By using optional external input/output adaptor (PAC-YG10HA) you can set and monitor the following. Input : By level signal : "Batch start/stop", "Batch emergency stop" By pulse signal : "Batch start/stop", "Enable/disable local remote controller" Output : "Start/stop", "Error/Normal"	○	○

\*NOTE: Operation and displayed content vary depending on the indoor unit model.  
◆Future release schedule is subject to change without notice.

## Centralized controller GB-50ADA-J\*

New



GB-50ADA (without display)

• Dimensions: 250 (W) x 217 (H) x 97.2 (D) mm  
: 9-7/8 (W) x 8-9/16 (H) x 3-7/8 (D) in.

\*GB-50ADA-J is indicated as GB-50ADA.

The Web Server Function enables Remote Operation or Scheduling Via a Web Browser on a Personal Computer!  
Up to 50 indoor units can be controlled!

### Web Browser

Enables monitoring and operation of indoor units using a PC with Microsoft® Internet Explorer (Ver.6 or 7 or 8) (Web browser function is an optional and needs license registration.)

\*When connecting to the Internet, please use the VPN (Virtual Private Network).

### Using "Dial-up Connection"

- Enables monitoring and operation from a remote place
- Enables error notification by e-mails to a PC or to a mobile phone

Function	Description
	<b>GB-50ADA (web browser)</b>
Controllable unit	Up to 50 units/groups.
Dimensions W x H x D	250 (9-7/8) x 217 (8-9/16) x 97.2 (3-7/8) mm (in)
ON / OFF	Run and stop operation for the air conditioner units
Mode selection	Switches between Cool / Dry / Auto / Fan / Heat.
Temperature setting	Range of temperature setting Cool/Dry : 19-30°C [14-30°C] / 67-87°F [57-87°F] Heat : 17-28°C [17-28°C] / 63-83°F [63-83°F] Auto : 19-28°C [17-28°C] / 67-83°F [63-83°F] ( ) in case of using middle-temperature on PEFY, PEFY-VML/VMR/VMS/VMH-by setting DipSW7-1 to ON. Yet, PEFY-P-VMH-E-F is excluded. *Range of temperature settings vary depending on model.
Air flow direction setting	Air flow direction angles, 4-angle or 5-angle Swing, Auto (Louver cannot be set)
Timer operation / Schedule	Annual/Weekly (2 types)/today schedule can be set for each group of air conditioning units. Optimized startup setting is also available.
Permit / Prohibit function	Individually prohibit operation of each local remote control function
Indoor unit intake temperature	Measures the intake temperature of the indoor unit only when the indoor unit is operating.
Error	When an error is currently occurring on an air conditioner unit, the afflicted unit and the error code are displayed.
Test run	-
Ventilation interlock	Operation of indoor groups or general equipment can be interlocked by the change of state (ON/OFF, mode, error of indoor groups and general equipment).

\*NOTE: Operation and displayed content vary depending on the indoor unit model. License registration is necessary to perform each function on GB-50ADA.

### System Structure

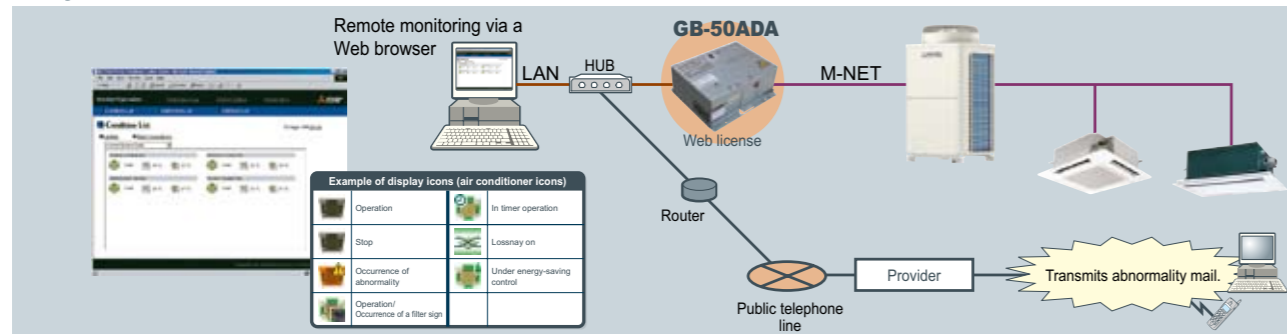

### Annual / Weekly Schedule

Enables Weekly and Annual scheduling with a registering license

- ON/OFF, operation mode, temperature setting, prohibit remote controller operation can be set.
- For annual schedule, it is possible to set 50 day-long settings up to 24 months into the future.



### Scheduling example in the office

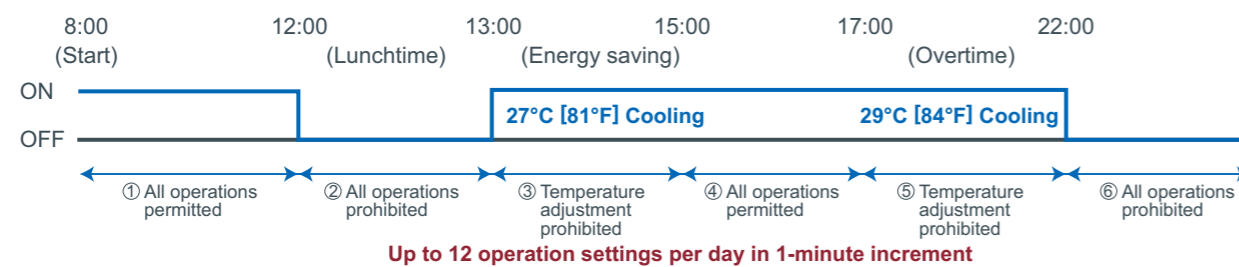

## Centralized Remote Controller

### PI Controller PAC-YG60MCA



Dimension: 200(W) x 120(H) x 45(D) mm  
: 7-7/8(W) x 4-3/4(H) x 1-13/16(D) in.

No more PLCs are needed!

Our new PI controller makes it possible to perform energy saving without PLC, which is cost saving. Maximum of 4 measurement meter (WHM, gas meter, water meter, calorie meter) can be connected to the PI controller and can be used also for charge calculation.

\*24 VDC power needs to be provided on site.

### Energy Saving Control

Enables Energy Saving Control with the use of our new PI controller. (Registration of "Energy Save" licence is required.)

To perform energy saving, the capacity of the outdoor unit is controlled.

\*Please note that when using an energy saving control, there are no warranties to failures such as usage over the contracted electricity.

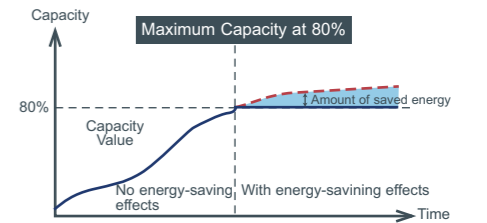

### System Structure

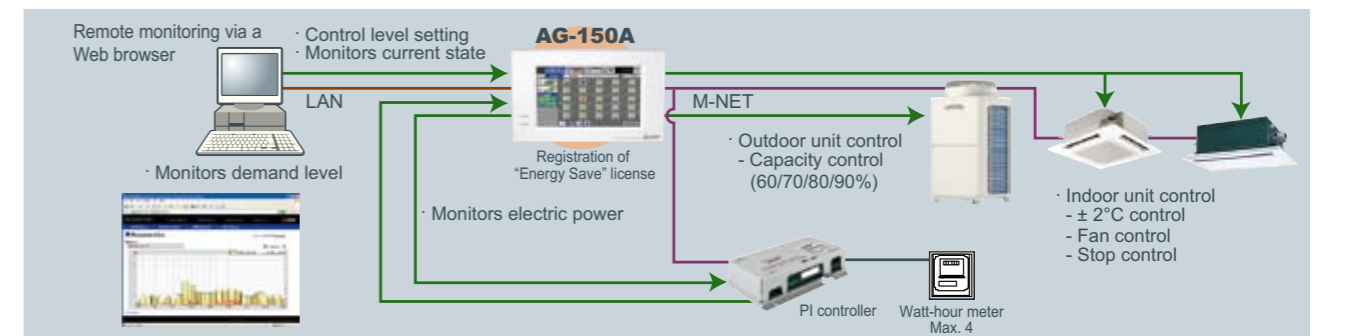

### Charge Calculation

Enables charge calculation for each tenant and output as CSV file

### System Structure

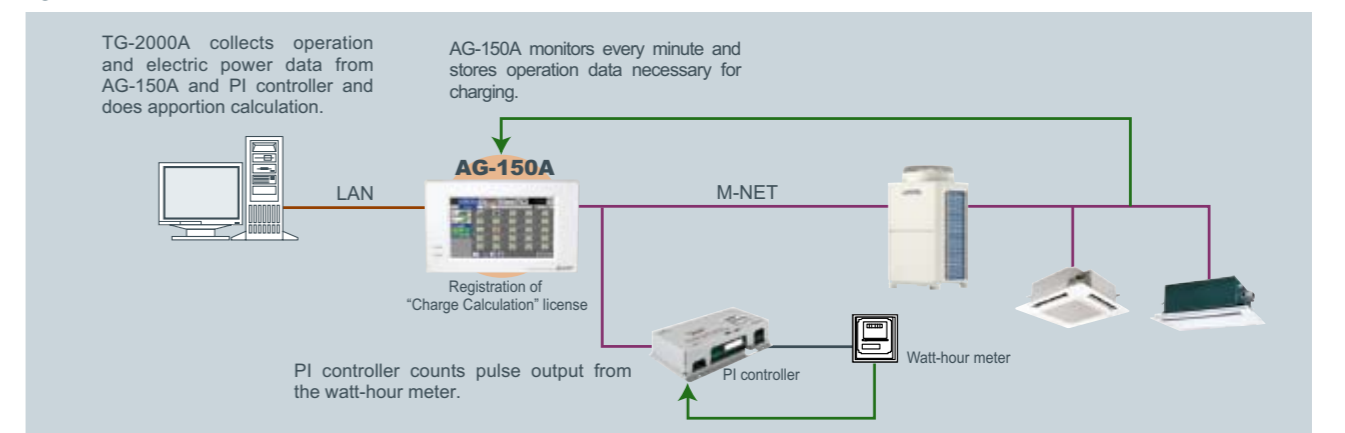

# Centralized Remote Controller

## DIDO Controller PAC-YG66DCA



Dimension: 200(W) x 120(H) x 45(D) mm  
: 7-7/8(W) x 4-3/4(H) x 1-13/16(D) in.

**No more PLCs are needed!**  
Our new DIDO controller makes it possible to control general-purpose equipment without PLC, which is cost saving. Up to 6 general-purpose equipment can be connected to the DIDO controller.

\*24 VDC power needs to be provided on site.

### General-purpose equipment Control

Enables to control and monitor equipment other than air-conditioners (air-conditioners of other companies, lights, ventilators, etc.)

#### System Structure

- In addition to above, the air-conditioners can be interlocked with general-purpose equipment. E.g. Interlock between indoor units and security system.
- The indoor units can be turned ON/OFF when the security system is activated/deactivated.

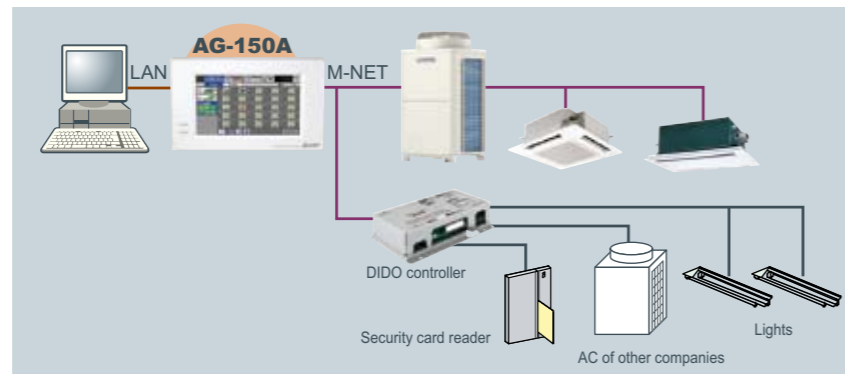
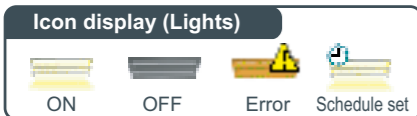

## AI Controller PAC-YG63MCA



Dimension: 200(W) x 120(H) x 45(D) mm  
: 7-7/8(W) x 4-3/4(H) x 1-13/16(D) in.

**Our new AI controller makes it possible to monitor the values measured by the temperature/humidity sensor connected to the AI controller.**

The AI controller has two input and two output channels.

\*24 VDC power needs to be provided on site.

### Temperature/Humidity Monitoring

Monitors the values measured by the temperature/humidity sensor connected to the AI controller

Temperature : Pt100, 4 to 20mA DC, 1 to 5 VDC, 0 to 10 VDC  
Humidity : 4 to 20mA DC, 1 to 5 VDC, 0 to 10 VDC

- Trend displays of measurement data can be shown on a Web browser.
- An alarm can be output by e-mail when measurement data exceeds a preset upper or lower limit.

#### System Structure

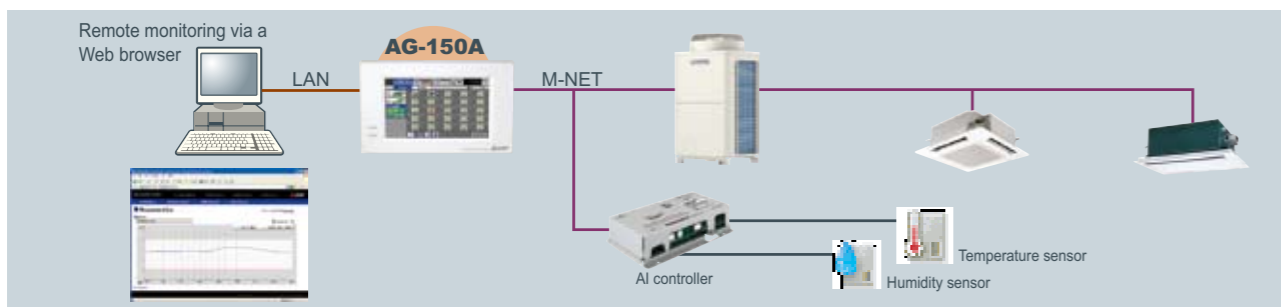

Remote Controller

## Integrated centralized control software TG-2000A

### Example of Basic System Configuration

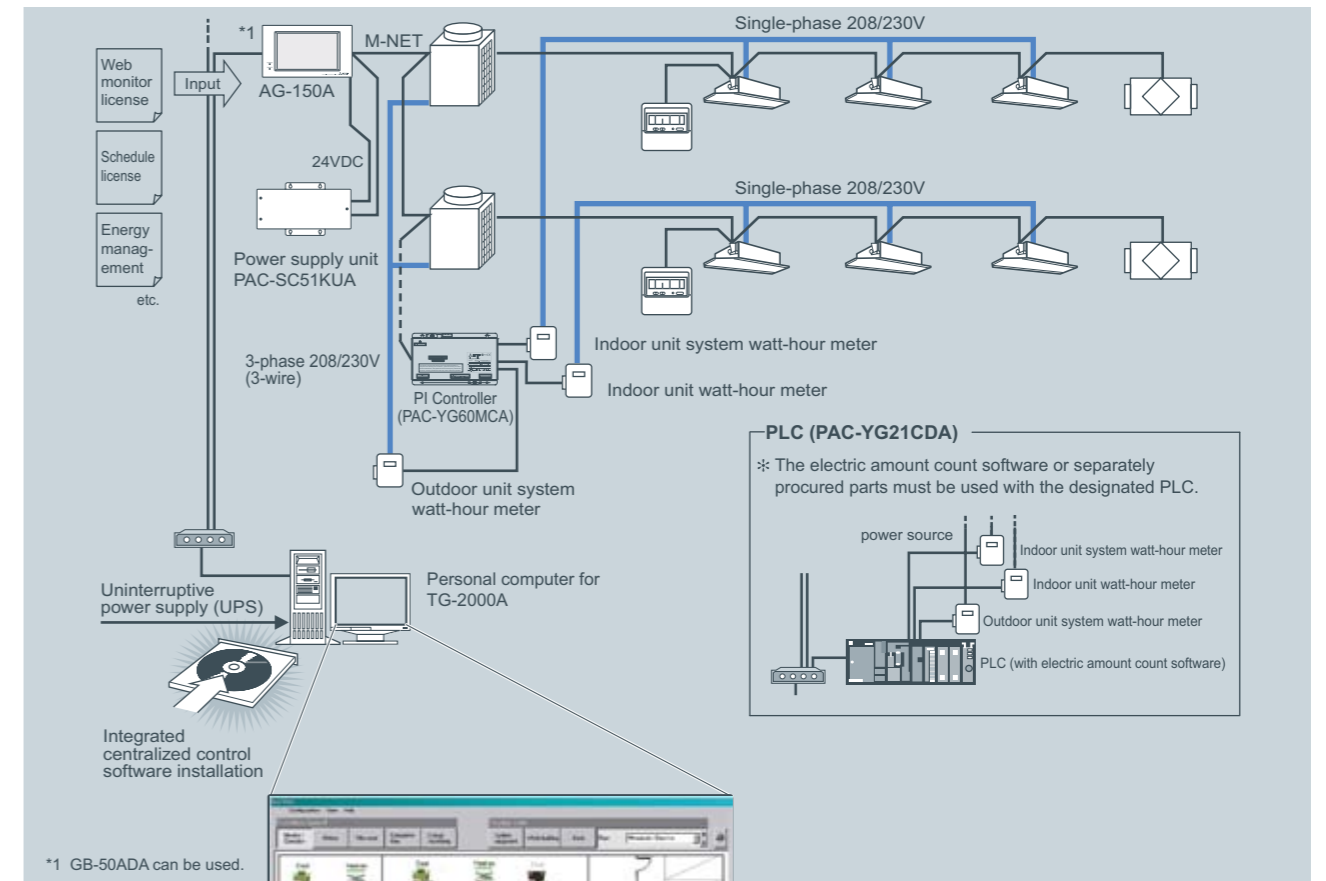

The air-conditioning layout can be displayed on the screen, making control and operation easier.

### Effective use of TG-2000A

Multiple air conditioning in multiple buildings can be calculated. The power apportionment percentage data and apportioned power rate can be calculated for each unit, and can be output as a CSV file.



For example, installing TG-2000A to the system in the headquarters makes it possible to control AG-150A/GB-50ADA units that are used in branch offices.

Remote Controller

## LONWORKS® (LMAP02)

CITY MULTI can easily combine into a Building Management System (BMS) via the LONWORKS® and M-NET adapter LMAP02. LONWORKS® is an opened transmission protocol widely used at BMS, and related equipment control. CITY MULTI is therefore compatible with large-scaled BMS management via LONWORKS®.

One LM ADAPTER unit can connect up to 50 Groups/50 indoor units.

Using a single LONWORKS® adapter (LM ADAPTER), you can connect up to a maximum of 50 indoor units.

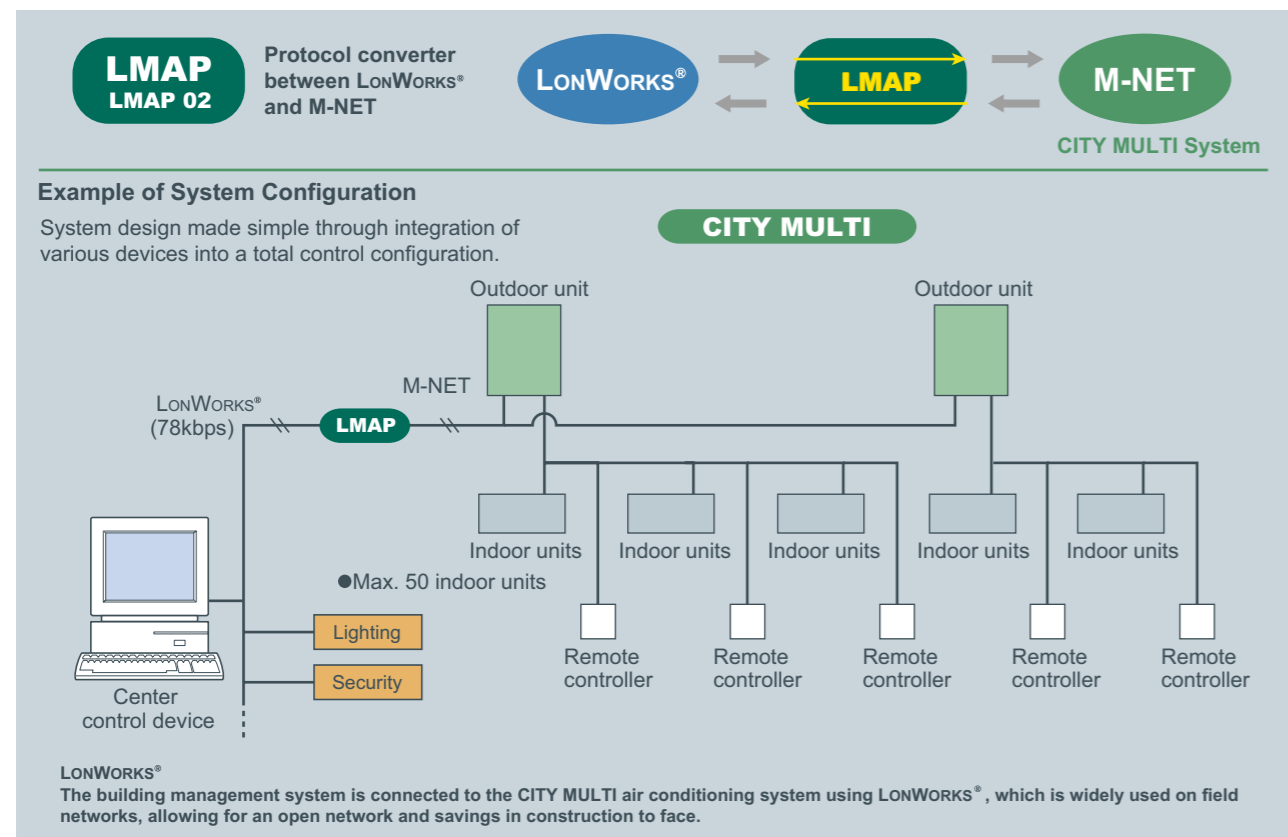

LON, LONWORKS® and the Echelon logo are trademarks of Echelon Corporation registered in the United States and other countries.

LONWORKS® INTERFACE	
FUNCTION	CONTENT
<b>Control</b>	
ON/OFF	Run/Stop
Mode Operation	Cool/Dry/Heat/Auto/Fan
Setpoint Adjustment	Cooling 19-30°C [67-87°F], Heating 17-28°C, [63-83°F], Auto 19-28°C [67-83°F]
Fan Speed Control	Lo-Mi1-Mi2-Hi
Permit/Prohibit	On/Off, Mode, Setpoint
Emergency Stop	-
<b>Monitoring</b>	
ON/OFF	Run/Stop
Mode	Cool/Dry/Heat/Auto/Fan
Setpoint	Cooling 19-30°C [67-87°F], Heating 17-28°C, [63-83°F], Auto 19-28°C [67-83°F]
Fan Speed	Lo-Mi1-Mi2-Hi
Permit/Prohibit	On/Off, Mode, Setpoint
Alarm State	-
Room Temperature	-10-50°C [14-122°F]
Thermo ON/OFF	On/Off

## BACnet® (BAC-HD150)

CITY MULTI can easily combine into a Building Management System (BMS) via the BACnet® and M-NET adapter BAC-HD150. BACnet is an opened transmission protocol widely used at BMS, and related equipment control. CITY MULTI is therefore compatible with large-scaled BMS management via BACnet.

BAC-HD150 can control up to 50 units/groups (including LOSSNAY).

Up to 150 units/groups (including LOSSNAY) can be controlled from one BAC-HD150 with three expansion controllers PAC-YG50ECA. (50 units/PAC-YG50ECA)

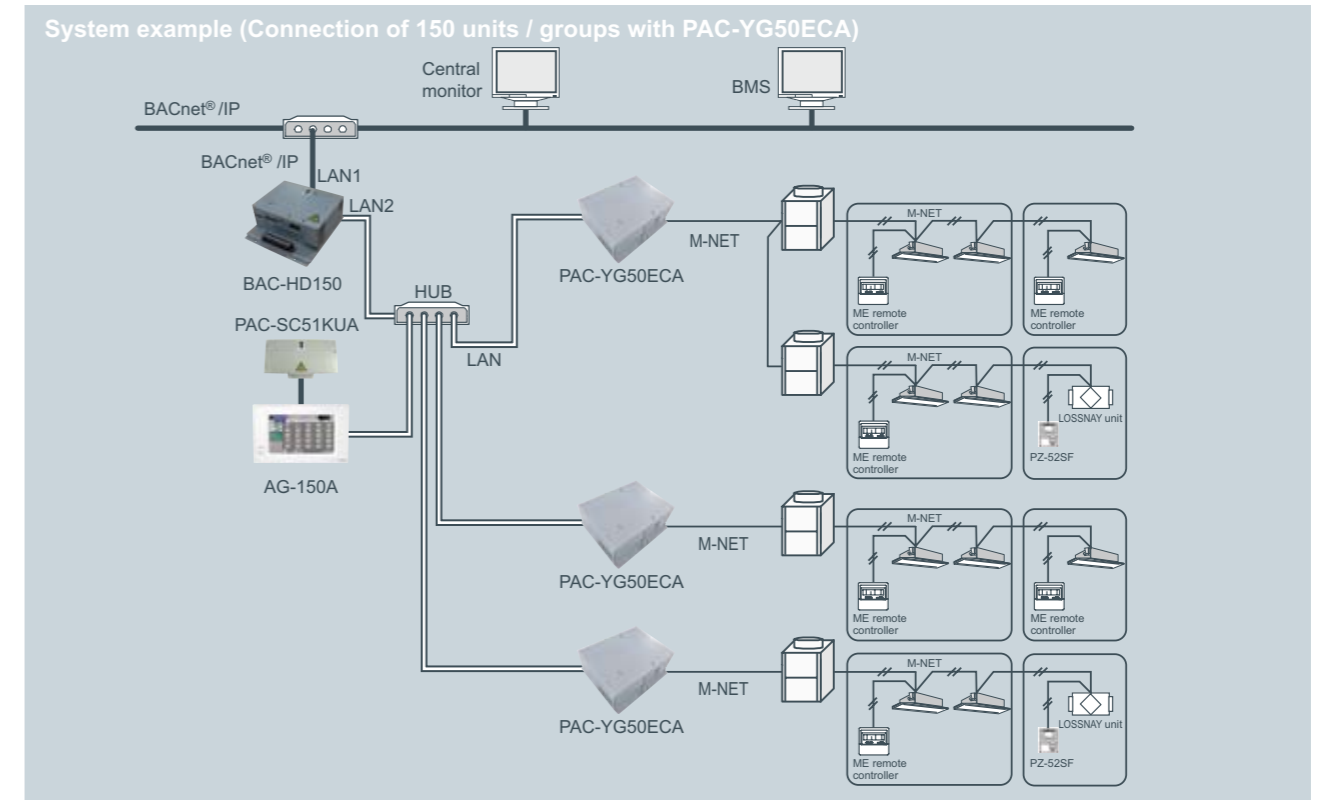

BACnet® and M-NET adapter	
FUNCTION	CONTENT
<b>Operation</b>	
ON/OFF	Run/Stop
Mode	Cool/Dry/Heat/Auto/Fan
Fan Speed	Low-Mid1-Mid2-Hi
Airflow Direction	Horizontal- 60°-80°-100°swing
Set Temperature	Cooling 19-30°C [67-87°F], Heating 17-28°C [63-83°F], Auto 19-28°C [67-83°F]
Filter Sign Reset	Normal/Reset
Permit/Prohibit	ON/OFF, Mode, Filter sign reset, Set temp.
Forced OFF	Release/Effective
<b>Monitoring</b>	
ON/OFF	Run/Stop
Mode	Cool/Dry/Heat/Auto/Fan
Fan Speed	Low-Mid1-Mid2-Hi
Air Direction	Horizontal- 60°-80°-100°swing
Set Temperature	Cooling 19-30°C [67-87°F], Heating 17-28°C [63-83°F], Auto 19-28°C [67-83°F]
Filter Sign	Normal/Reset
Permit/Prohibit	ON/OFF, Mode, Filter sign reset, Set temp.
Indoor Temperature	-
Alarm Signal	Normal/Abnormal
Error Code	2 Character code- Indicates all unit alarms
Communication State	Normal/Abnormal



## Wide selection of indoor units

# I ndoor unit

- Ceiling cassette type 4-way airflow
- Ceiling cassette type 2-way airflow
- Ceiling cassette type 1-way airflow
- Ceiling concealed type
- Fresh Air Intake type
- Ceiling suspended type
- Wall mounted type
- Floor standing exposed
- Floor mounted concealed type
- BC controller
-  Logsnay
- OA Processing Units

**Ceiling cassette (4-way air flow)** Page41 - Page42

*i-see Sensor* **PLFY-P VBM-E**  
**PLFY-P VCM-E**

Model	P20	P25	P32	P40	P50
Capacity	2.2kW	2.8kW	3.6kW	4.5kW	5.6kW
Model	P63	P80	P100	P125	
Capacity	7.1kW	9.0kW	11.2kW	14.0kW	

**Fresh Air Intake** Page55 - Page56

**PEFY-P VMH-E-F**

Model	P80	P140	P200	P250
Capacity	9.0kW	16.0kW	22.4kW	28.0kW

**Ceiling cassette (2-way air flow)** Page43 - Page44

**PLFY-P VLMD-E**

Model	P20	P25	P32	P40	P50
Capacity	2.2kW	2.8kW	3.6kW	4.5kW	5.6kW
Model	P63	P80	P100	P125	
Capacity	7.1kW	9.0kW	11.2kW	14.0kW	

**Ceiling suspended** Page57 - Page58

**PCFY-P VKM-E**

Model	P40	P63	P100	P125
Capacity	4.5kW	7.1kW	11.2kW	14.0kW

**Ceiling cassette (1-way air flow)** Page45 - Page46

**PMFY-P VBM-E**

Model	P20	P25	P32	P40
Capacity	2.2kW	2.8kW	3.6kW	4.5kW

**Wall mounted** Page59 - Page60

**PKFY-P VBM-E**  
**PKFY-P VKM-E**  
**PKFY-P VHM-E**

Model	P15	P20	P25	P32	P40	P50	P63	P100
Capacity	1.7kW	2.2kW	2.8kW	3.6kW	4.5kW	5.6kW	7.1kW	11.2kW

**Ceiling concealed** Page47 - Page54

**PEFY-P VMR-E-L/R** **PEFY-P VMA(L)-E**  
**PEFY-P VMS1(L)-E** **PEFY-P VMH(S)-E**

Model	P15	P20	P25	P32	P40	P50	P63
Capacity	1.7kW	2.2kW	2.8kW	3.6kW	4.5kW	5.6kW	7.1kW
Model	P71	P80	P100	P125	P140	P200	P250
Capacity	8.0kW	9.0kW	11.2kW	14.0kW	16.0kW	22.4kW	28.0kW

**Floor standing / Floor mounted concealed** Page61 - Page66

**PFFY-P VLEM-E** **PFFY-P VKM-E**  
**PFFY-P VLRM-E** **PFFY-P VLRRM-E**

Model	P20	P25	P32	P40	P50	P63
Capacity	2.2kW	2.8kW	3.6kW	4.5kW	5.6kW	7.1kW

# INDOOR UNIT Ceiling cassette type 4-way airflow

## PLFY-P VBM-E i-see Sensor PLFY-P VCM-E

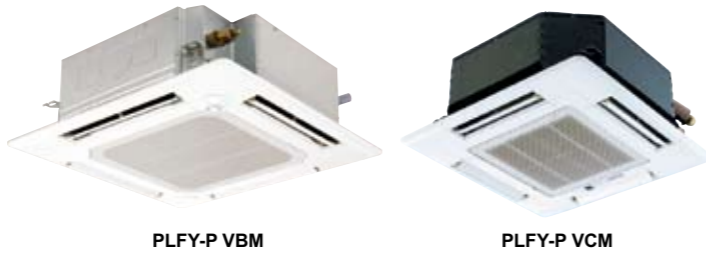

The new 4-way cassette VBM offers 72 different airflow patterns, making it ideal for applications with ceilings up to 4.2 m (13-13/16ft) in height.



Compact body to match with 2 feet (600mm) x 2 feet (600mm) ceiling design (VCM)

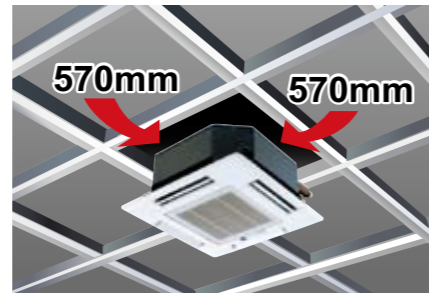

## Specifications

		PLFY-P32VBM-E	PLFY-P40VBM-E	PLFY-P50VBM-E	PLFY-P63VBM-E	PLFY-P80VBM-E	PLFY-P100VBM-E	PLFY-P125VBM-E
Power source		1-phase 220-240V 50Hz / 1-phase 200V 60Hz						
Cooling capacity	*1 kW	3.6	4.5	5.6	7.1	9.0	11.2	14.0
	*1 BTU/h	12,300	15,400	19,100	24,200	30,700	38,200	47,800
Heating capacity	*1 kW	4.0	5.0	6.3	8.0	10.0	12.5	16.0
	*1 BTU/h	13,600	17,100	21,500	27,300	34,100	42,700	54,600
Power consumption	Cooling kW	0.03	0.04	0.05	0.07	0.15	0.16	0.16
	Heating kW	0.02	0.03	0.04	0.06	0.14	0.15	0.15
Current	Cooling A	0.22	0.29	0.36	0.51	1.00	1.07	1.07
	Heating A	0.14	0.22	0.29	0.43	0.94	1.00	1.00
External finish (Munsell No.)		Galvanized steel sheet White (6.4Y 8.9/0.4)						
Dimension H x W x D	Unit mm(in.)	258 x 840 x 840 (10-3/16 x 33-8/1 x 33-8/1)					298 x 840 x 840 (11-3/4 x 33-1/8 x 33-1/8)	
	Panel mm(in.)	35 x 950 x 950 (1-3/8 x 37-7/16 x 37-7/16)						
Net weight	Unit kg(lbs.)	22 (49)		23 (51)		27 (60)		
	Panel kg(lbs.)	6 (13)						
Heat exchanger		Cross fin (Aluminum plate fin and copper tube)						
Fan	Type x Quantity	Turbo fan x 1						
	Airflow rate *2 (Lo-Mid1-Mid2-Hi)	m³/min	11-12-13-14	12-13-14-16	14-15-16-18	16-18-20-22	21-24-27-29	22-25-28-30
		L/s	183-200-217-233	200-217-233-267	233-250-267-300	267-300-333-367	350-400-450-483	367-417-467-500
	cfm	388-424-459-494	424-459-494-565	494-530-565-636	565-636-706-777	742-848-953-1024	777-883-989-1059	
External static pressure	Pa	0						
Motor	Type	DC motor						
	Output kW	0.050					0.120	
Air filter		PP Honeycomb						
Refrigerant pipe diameter	Gas (Flare) mm(in.)	ø12.7 (ø1/2)		ø12.7 (ø1/2) / ø15.88 (ø5/8) (Compatible)		ø15.88 (ø5/8)		ø15.88 (ø5/8) / ø19.05 (ø3/4) (Compatible)
	Liquid (Flare) mm(in.)	ø6.35 (ø1/4)		ø6.35 (ø1/4) / ø9.52 (ø3/8) (Compatible)		ø9.52 (ø3/8)		
Field drain pipe diameter		mm(in.) O.D. 32 (1-1/4)						
Sound pressure level (Lo-Mid1-Mid2-Hi) *2 *3		dB(A)	27-28-29-31	27-28-30-31	28-29-30-32	30-32-35-37	34-37-39-41	35-38-41-43

### Automatic Air Speed Adjustment

Auto-fan-speed mode enables speedy and comfortable heating during heating startup.

The Auto-fan-speed mode is added to the usual four steps "Low, Mid1, Mid2, High." The Auto-fan-speed mode enables speedy and comfortable air conditioning because the air flow speeds up when starting, and air flow slows down when the air conditioning becomes stable. (PLFY-P VBM-E ONLY)



\*When using a wireless remote controller, initial settings are required.

### Draft-less Air Distribution

The horizontal blow mode\* newly employed supplies airflow horizontally not bringing cooled/warmed air directly to occupants thus preventing discomfort sensation due to excessive cooling or direct exposing of occupants to the air blow. (PLFY-P VBM-E ONLY)

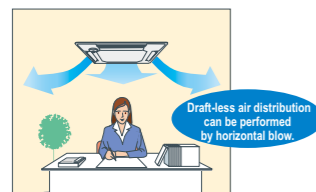

\*Default  
\*The ceiling may be smudged at a spot where the supplied airflow is seriously disturbed.

### Wide Air Flow (PLFY-P VBM-E ONLY)

#### Cooling softly with Wide Air Flow

Discharge air reaches wider area and the fan speed is decreased by 20% thanks to the new wide shape air outlet.



72 patterns of airflow to accommodate any room layout are available. \*First in the industry

The number of outlet can be set to 4, 3, or 2. Flexible airflow is available by fixing the up-down airflow direction of the outlet with a wired remote controller (or manually).

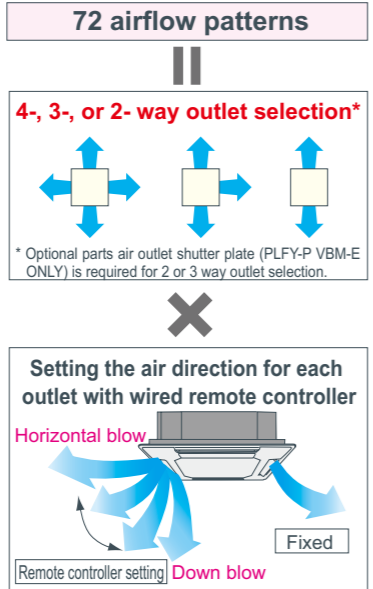

### "i-see sensor" can be used with ceiling cassette type 4-way airflow unit. (Option PAC-SA1ME-E, PLYF-VBM-E ONLY)

New 4-way Cassette PLYF-VBM controls the temperature difference at the top and bottom in a room by checking the floor temperature with "i-see sensor". Comfortable air conditioning can be realized smoothly with "sensible temperature control." (Option PAC-SA1ME-E, PLYF-VBM-E ONLY)

#### Prevents overcooling/overheating, and improves comfort/energy-efficiency

Without i-see sensor: preset temperature at 23°C

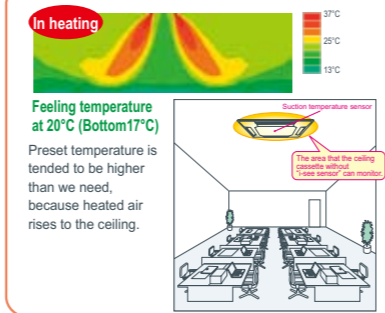

With i-see sensor+Auto fan speed: preset temperature at 20°C

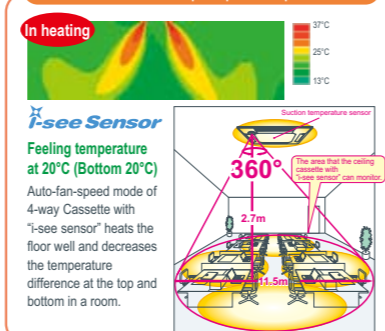

		PLFY-P20VCM-E	PLFY-P25VCM-E	PLFY-P32VCM-E	PLFY-P40VCM-E	
Power source		1-phase 220-240V 50Hz				
Cooling capacity	*1 kW	2.2	2.8	3.6	4.5	
	*1 BTU/h	7,500	9,600	12,300	15,400	
Heating capacity	*1 kW	2.5	3.2	4.0	5.0	
	*1 BTU/h	8,500	10,900	13,600	17,100	
Power consumption	Cooling kW	0.05	0.05	0.06	0.06	
	Heating kW	0.05	0.05	0.06	0.06	
Current	Cooling A	0.23	0.23	0.28	0.28	
	Heating A	0.23	0.23	0.28	0.28	
External finish (Munsell No.)		Galvanized steel sheet with gray heat insulation White (6.4Y 8.9/0.4)				
Dimension H x W x D	Unit mm(in.)	208 x 570 x 570 (8-1/4 x 22-1/2 x 22-1/2)				
	Panel mm(in.)	20 x 650 x 650 (13/16 x 25-5/8 x 25-5/8)				
Net weight	Unit kg(lbs.)	15.5 (35)		17 (38)		
	Panel kg(lbs.)	3 (7)		3 (7)		
Heat exchanger		Cross fin (Aluminum plate fin and copper tube)				
Fan	Type x Quantity	Turbo fan x 1				
	Airflow rate *2 (Lo-Mid-Hi)	m³/min	8-9-10	8-9-10	8-9-11	8-9-11
		L/s	133-150-167	133-150-167	133-150-183	133-150-183
	cfm	283-318-353	283-318-353	283-318-388	283-318-388	
External static pressure	Pa	0 (direct blow)				
Motor	Type	1-phase induction motor				
	Output kW	0.011	0.015	0.02	0.02	
Air filter		PP Honeycomb (long life type)				
Refrigerant pipe diameter	Gas (Flare) mm(in.)	ø12.7 (ø1/2)				
	Liquid (Flare) mm(in.)	ø6.35 (ø1/4)				
Field drain pipe diameter		mm(in.) O.D. 32 (1-1/4)				
Sound pressure level (Lo-Mid-Hi) *2 *3		dB(A)	28-31-35	28-31-37	29-33-38	30-34-39

### Notes:

- \*1 Cooling/Heating capacity indicates the maximum value at operation under the following condition.  
Cooling : Indoor 27°C(81°F)DB/19°C(66°F)WB, Outdoor 35°C(95°F)DB  
Heating : Indoor 20°C(68°F)DB, Outdoor 7°C(45°F)DB/6°C(43°F)WB
- \*2 Airflow rate/Sound pressure level are in (low-middle-high) or (low-middle1-middle2-high).
- \*3 It is measured in anechoic room at power source 230V.

# INDOOR UNIT

## Ceiling cassette type

### 2-way airflow

# PLFY-P VLMD-E



Slim body of 290mm(11-7/16in.) height



Equipped with drain pump mechanism as standard

The drain can be positioned anywhere up to 583mm(22-15/16in.) from the ceiling's surface, providing greater freedom with long cross-piping and allowing more versatility with piping layouts.

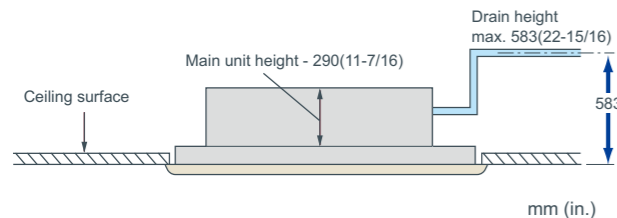

Compact unit and low noise level attained!

Sound pressure level table (Standard static pressure) at 0Pa

Sound pressure Level	Capacity	dB(A)									
		P20	P25	P32	P40	P50	P63	P80	P100	P125	
		Fan Speed	High	33	36	37	39	39	42	46	
	Mid	30	33	34	37	36	39	42/44			
	Low	27	29	31	32	33	36	40			

<220V,240V>

Sound pressure Level	Capacity	dB(A)									
		P20	P25	P32	P40	P50	P63	P80	P100	P125	
		Fan Speed	High	34	37	38	40	40	43	46	
	Mid	31	34	35	38	37	41	42/44			
	Low	28	30	32	33	34	37	40			

<230V>

Slim body - only 290mm(11-7/16in.) height

The slimline body is highly suitable for installation in narrow ceiling spaces and for replacing obsolete air-conditioning equipment in older buildings. The main unit is only 290mm(11-7/16in.) height.

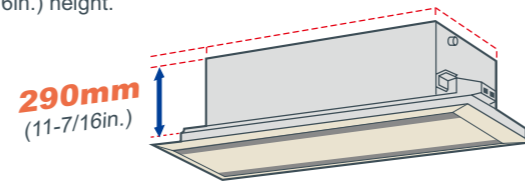

Terminal block on outside of main unit makes wiring easier

Fresh air directly taken in

Fresh air can be taken in to the main unit directly (optional accessories needed.)

Long life filter equipped as standard

The antibacterial long life filter does not require maintenance for approximately a year.

Easy installation

Lighter panel and placing the electric board near the panel make installation and maintenance easier. Also, the heat exchanger is washable by displacing the center panel, filter, and fan.

## Specifications

		PLFY-P20VLMD-E	PLFY-P25VLMD-E	PLFY-P32VLMD-E	PLFY-P40VLMD-E	
Power source		1-phase 220-240V 50Hz / 1-phase 220-230V 60Hz				
Cooling capacity	*1 kW	2.2	2.8	3.6	4.5	
	*1 BTU/h	7,500	9,600	12,300	15,400	
Heating capacity	*1 kW	2.5	3.2	4.0	5.0	
	*1 BTU/h	8,500	10,900	13,600	17,100	
Power consumption	Cooling kW	0.072 / 0.075	0.072 / 0.075	0.072 / 0.075	0.081 / 0.085	
	Heating kW	0.065 / 0.069	0.065 / 0.069	0.065 / 0.069	0.074 / 0.079	
Current	Cooling A	0.36 / 0.37	0.36 / 0.37	0.36 / 0.37	0.40 / 0.42	
	Heating A	0.30 / 0.32	0.30 / 0.32	0.30 / 0.32	0.34 / 0.37	
External finish (Munsell No.)	Unit	Galvanized steel plate				
	Panel	Pure white (6.4Y 8.9/0.4)				
Dimension H x W x D	Unit mm (in.)	290 x 776 x 634 (11-7/16 x 30-9/16 x 25)				
	Panel mm (in.)	20 x 1080 x 710 (13/16 x 42-9/16 x 28)				
Net weight	Unit kg(lbs.)	23 (51)		24 (53)		
	Panel kg(lbs.)	6.5 (15)				
Heat exchanger		Cross fin				
Fan	Type x Quantity	Turbo fan x 1				
	Airflow rate *2 (Lo-Mid-Hi)	m <sup>3</sup> /min	6.5-8.0-9.5		7.0-8.5-10.5	
		L/s	108-133-158		117-142-175	
		cfm	230-283-335		247-300-371	
	External static pressure Pa	0				
Motor	Type	1-phase induction motor				
	Output kW	0.015 (at 240V)				
Air filter		PP honeycomb fabric (long life type)				
Refrigerant	Gas(Flare) mm(in.)	ø12.7 (ø1/2)				
pipe diameter	Liquid(Flare) mm(in.)	ø6.35 (ø1/4)				
Field drain pipe diameter	mm(in.)	O.D.32 (1-1/4)				
Sound pressure level (Lo-Mid-Hi) *2 *3	220V/240V dB(A)	27-30-33		29-33-36		
	230V dB(A)	28-31-34		30-34-37		

		PLFY-P50VLMD-E	PLFY-P63VLMD-E	PLFY-P80VLMD-E	PLFY-P100VLMD-E	PLFY-P125VLMD-E	
Power source		1-phase 220-240V 50Hz / 1-phase 220-230V 60Hz					
Cooling capacity	*1 kW	5.6	7.1	9.0	11.2	14.0	
	*1 BTU/h	19,100	24,200	30,700	38,200	47,800	
Heating capacity	*1 kW	6.3	8.0	10.0	12.5	16.0	
	*1 BTU/h	21,500	27,300	34,100	42,700	54,600	
Power consumption	Cooling kW	0.082 / 0.086	0.101 / 0.105	0.147 / 0.156	0.157 / 0.186	0.28 / 0.28	
	Heating kW	0.075 / 0.080	0.094 / 0.099	0.140 / 0.150	0.150 / 0.180	0.27 / 0.27	
Current	Cooling A	0.41 / 0.43	0.49 / 0.51	0.72 / 0.74	0.75 / 0.88	1.35 / 1.35	
	Heating A	0.35 / 0.38	0.43 / 0.46	0.66 / 0.69	0.69 / 0.83	1.33 / 1.33	
External finish (Munsell No.)	Unit	Galvanized steel plate					
	Panel	Pure white (6.4Y 8.9 / 0.4)					
Dimension H x W x D	Unit mm (in.)	290 x 946 x 634 (11-7/16 x 37-1/4 x 25)		290 x 1446 x 634 (11-7/16 x 56-15/16 x 25)		280 x 1708 x 606 (11-7/16 x 67-1/4 x 23-7/8)	
	Panel mm (in.)	20 x 1250 x 710 (13/16 x 49-1/4 x 28)		20 x 1750 x 710 (13/16 x 68-15/16 x 28)		20 x 2010 x 710 (13/16 x 79-3/16 x 28)	
Net weight	Unit kg(lbs.)	27 (60)	28 (62)	44 (98)	47 (104)	56 (124)	
	Panel kg(lbs.)	7.5 (17)		12.5 (28)		13.0 (29)	
Heat exchanger		Turbo fan x 1		Turbo fan x 2		Sirocco fan x 4	
Fan	Type x Quantity	Turbo fan x 1		Turbo fan x 2		Sirocco fan x 4	
	Airflow rate *2 (P50-P100:Lo-Mid-Hi) (P125:Lo-Mid2-Mid1-Hi)	m <sup>3</sup> /min	9.0-11.0-12.5	11.0-13.0-15.5	15.5-18.5-22.0	17.5-21.0-25.0	24.0-27.0-30.0-33.0
		L/s	150-183-208	167-217-258	258-308-367	292-350-417	400-450-500-550
		cfm	318-388-441	353-459-547	547-653-777	618-742-883	848-953-1,059-1,165
	External static pressure Pa	0					
Motor	Type	1-phase induction motor					
	Output kW	0.020 (at 240V)		0.020 (at 240V)		0.030 (at 240V)	
Air filter		PP honeycomb fabric (long life type)				Synthetic fiber unwoven cloth filter (long life)	
Refrigerant pipe diameter	Gas (Flare) mm(in.)	ø12.7 (ø1/2)		ø15.88 (ø5/8)			
	Liquid (Flare) mm(in.)	ø6.35 (ø1/4)		ø9.52 (ø3/8)			
Field drain pipe diameter	mm(in.)	O.D.32 (1-1/4)					
Sound pressure level (Lo-Mid-Hi) *2 *3	220V/240V dB(A)	31-34-37	32-37-39	33-36-39	36-39-42	40-42-44-46	
	230V dB(A)	32-35-38	33-38-40	34-37-40	37-41-43	(Lo-Mid2-Mid1-Hi)	

### Notes:

\*1 Cooling/Heating capacity indicates the maximum value at operation under the following condition.

Cooling : Indoor 27°C(81°F)DB/19°C(66°F)WB, Outdoor 35°C(95°F)DB  
 Heating : Indoor 20°C(68°F)DB, Outdoor 7°C(45°F)DB/6°C(43°F)WB

\*2 Airflow rate/Sound pressure level are in (low-middle-high) or (low-middle2-middle1-high).

\*3 It is measured in anechoic room.

# INDOOR UNIT

## Ceiling cassette type

### 1-way airflow

## PMFY-P VBM-E



Compact and lightweight body perfect for limited ceiling space applications.



#### Compact size for smooth installation and maintenance

Unit body size has been standardized for all models at 812mm for easier installation. Body weight is only 14kg for the main unit and 3kg for the panel, making this unit one of the lightest in the industry.

#### Quiet operation

Newly developed airflow control technology reduces noise level to only 27dB (P20VBM) for industry-leading quiet performance.

#### Sound pressure level table

Sound pressure level	Capacity				
	P20	P25	P32	P40	
Fan Speed	High	35	37	39	
	Mid 1	33	36	37	
	Mid 2	30	34	35	
	Low	27	32	33	

<220V,240V>

#### Drain pump

The drain can be positioned anywhere up to 600mm(23-5/8in.) from the ceiling's surface.

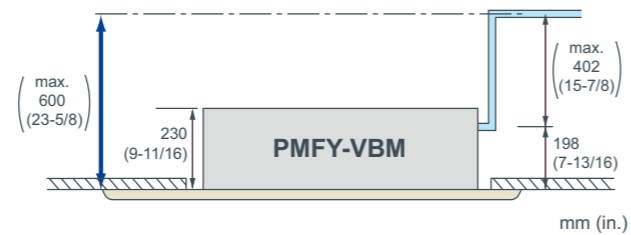

## ► Specifications

		PMFY-P20VBM-E	PMFY-P25VBM-E	PMFY-P32VBM-E	PMFY-P40VBM-E
Power source		1-phase 220-240V 50Hz / 1-phase 220V 60Hz			
Cooling capacity	*1 kW	2.2	2.8	3.6	4.5
	*1 BTU/h	7,500	9,600	12,300	15,400
Heating capacity	*1 kW	2.5	3.2	4.0	5.0
	*1 BTU/h	8,500	10,900	13,600	17,100
Power consumption	Cooling kW	0.042	0.044		0.054
	Heating kW	0.042	0.044		0.054
Current	Cooling A	0.20	0.21		0.26
	Heating A	0.20	0.21		0.26
External finish (Munsell No.)		White (0.98Y 8.99/0.63)			
Dimension	Unit mm(in.)	230 x 812 x 395 (9-1/16 x 32 x 15-9/16)			
	H x W x D Panel mm(in.)	30 x 1000 x 470 (1-3/16 x 39-3/8 x 18-9/16)			
Net weight	Unit kg(lbs.)	14 (31)			
	Panel kg(lbs.)	3 (7)			
Heat exchanger		Cross fin (Aluminum plate fin and copper tube)			
Fan	Type	Line flow fan x 1			
	Airflow rate *2	m <sup>3</sup> /min	6.5-7.2-8.0-8.7	7.3-8.0-8.6-9.3	7.7-8.7-9.7-10.7
		L/s	108-120-133-145	122-133-143-155	128-145-162-178
	(Lo-Mid2-Mid1-Hi) cfm	230-254-283-307	258-283-304-328	272-307-343-378	
External static pressure	Pa	0			
Motor	Type	1-phase induction motor			
	Output kW	0.028			
Air filter		PP Honeycomb fabric			
Refrigerant	Gas(Flare) mm(in.)	ø12.7 (ø1/2)			
	Liquid(Flare) mm(in.)	ø6.35 (ø1/4)			
Field drain pipe diameter		mm(in.) O.D. 26 (1)			
Sound pressure level (Lo-Mid2-Mid1-Hi) *2 *3	dB(A)	27-30-33-35	32-34-36-37	33-35-37-39	

#### Notes:

- \*1 Cooling/Heating capacity indicates the maximum value at operation under the following condition.  
Cooling : Indoor 27°C(81°F)DB/19°C(66°F)WB, Outdoor 35°C(95°F)DB  
Heating : Indoor 20°C(68°F)DB, Outdoor 7°C(45°F)DB/6°C(43°F)WB
- \*2 Airflow rate/Sound pressure level are in (low-middle2-middle1-high).
- \*3 It is measured in anechoic room.

# INDOOR UNIT

## Ceiling concealed type



### PEFY-P VMR-E-L/R

Static Pressure <b>5Pa</b>	Width <b>640mm</b> 25-6/32in.	Ultra Low Noise	Piping connection L model R model
-------------------------------	-------------------------------------	--------------------	---

Problem solver for residential hotels, museums, libraries, or hospitals where low noise is especially a must!

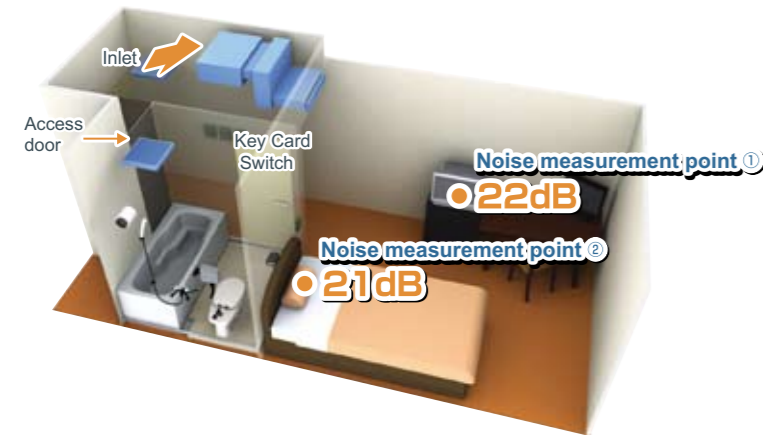

#### Operable by key card switch

It is possible to operate / stop by taking a key card in and out.

#### Enables to install for symmetric design room

Left or right piping and control boxes are available depending on the layout of each room. Plus, as in the above figure, easy maintenance is possible from the access door in the bathroom. \*Seen from the front, the pipe and control box are on the right side for -R models.

#### Easy Maintenance

Drain pan and heat exchangers are washable from the access door in the bathroom, making maintenance easy and cost saving.

#### Ultra low noise

Quiet indoor environment can be achieved with 21dB around the bed and 22dB around the desk. \*The noise level may differ by the room size or the setting of the unit.

#### Energy saving

Energy saving can be realized by preventing us from failing to switch off of the air conditioners with a centralized system when no one is in the room. Note: Compact and simple controllers, designed specifically to control only start/stop, fan speed and temperature can be set in each room for the occupants' enhanced individual comfort.

## Specifications

		PEFY-P20VMR-E-L	PEFY-P25VMR-E-L	PEFY-P32VMR-E-L
Power source		1-phase 220-230-240V 50Hz / 1-phase 220-230V 60Hz		
Cooling capacity	*1 kW	2.2	2.8	3.6
	*1 BTU/h	7,500	9,600	12,300
Heating capacity	*1 kW	2.5	3.2	4.0
	*1 BTU/h	8,500	10,900	13,600
Power consumption	Cooling kW	0.06 / 0.06	0.06 / 0.06	0.07 / 0.08
	Heating kW	0.06 / 0.06	0.06 / 0.06	0.07 / 0.08
Current	Cooling A	0.29 / 0.29	0.29 / 0.29	0.34 / 0.38
	Heating A	0.29 / 0.29	0.29 / 0.29	0.34 / 0.38
External finish		Galvanized		
Dimension H x W x D	Rear inlet mm (in.)	292 x 640 x 580 (11-1/2 x 25-1/4 x 22-7/8)		
	Bottom inlet mm (in.)	300 x 640 x 570 (11-7/8 x 25-1/4 x 22-1/2)		
Net weight		18 (40)		
Heat exchanger		Cross fin (Aluminum fin and copper tube)		
Fan	Type x Quantity	Sirocco fan x 1		
	Airflow rate (Lo-Mid-Hi)	m <sup>3</sup> /min	4.8-5.8-7.9	4.8-5.8-9.3
		L/s	80-97-132	80-97-155
		cfm	170-205-279	170-205-328
External static pressure *2	Pa	5		
Motor		1-phase induction motor		
Output		kW	0.018	0.023
Air filter		PP Honeycomb fabric (washable)		
Refrigerant	Gas	mm(in.)	ø12.7 (ø1/2) Brazed	
pipe diameter	Liquid	mm(in.)	ø6.35 (ø1/4) Brazed	
Field drain pipe diameter		mm(in.)	O.D. 26 (1)	
Sound pressure level (Lo-Mid-Hi) *3	220V	dB(A)	20-25-30	20-25-33
	230V		21-26-32	21-26-35
	240V		22-27-30	22-27-33

		PEFY-P20VMR-E-R	PEFY-P25VMR-E-R	PEFY-P32VMR-E-R
Power source		1-phase 220-230-240V 50Hz / 1-phase 220-230V 60Hz		
Cooling capacity	*1 kW	2.2	2.8	3.6
	*1 BTU/h	7,500	9,600	12,300
Heating capacity	*1 kW	2.5	3.2	4.0
	*1 BTU/h	8,500	10,900	13,600
Power consumption	Cooling kW	0.06 / 0.06	0.06 / 0.06	0.07 / 0.08
	Heating kW	0.06 / 0.06	0.06 / 0.06	0.07 / 0.08
Current	Cooling A	0.29 / 0.29	0.29 / 0.29	0.34 / 0.38
	Heating A	0.29 / 0.29	0.29 / 0.29	0.34 / 0.38
External finish		Galvanized		
Dimension H x W x D	Rear inlet mm (in.)	292 x 640 x 580 (11-1/2 x 25-1/4 x 22-7/8)		
	Bottom inlet mm (in.)	300 x 640 x 570 (11-7/8 x 25-1/4 x 22-1/2)		
Net weight		18 (40)		
Heat exchanger		Cross fin (Aluminum fin and copper tube)		
Fan	Type x Quantity	Sirocco fan x 1		
	Airflow rate (Lo-Mid-Hi)	m <sup>3</sup> /min	4.8-5.8-7.9	4.8-5.8-9.3
		L/s	80-97-132	80-97-155
		cfm	170-205-279	170-205-328
External static pressure *2	Pa	5		
Motor		1-phase induction motor		
Output		kW	0.018	0.023
Air filter		PP Honeycomb fabric (washable)		
Refrigerant	Gas	mm(in.)	ø12.7 (ø1/2) Brazed	
pipe diameter	Liquid	mm(in.)	ø6.35 (ø1/4) Brazed	
Field drain pipe diameter		mm(in.)	O.D. 26(1)	
Sound pressure level (Lo-Mid-Hi) *3	220V	dB(A)	20-25-30	20-25-33
	230V		21-26-32	21-26-35
	240V		22-27-30	22-27-33

#### Notes:

\*1 Cooling/Heating capacity indicates the maximum value at operation under the following condition.  
Cooling : Indoor 27°C (81°F) DB/19°C (66°F) WB, Outdoor 35°C (95°F) DB  
Heating : Indoor 20°C (68°F) DB, Outdoor 7°C (45°F) DB/6°C (43°F) WB

\*2 The external static pressure is set to 5Pa (at 220V, 230V, 240V).

\*3 Measured in anechoic room. Sound pressure levels of the unit with a rear air inlet. (Sound pressure levels are higher than the unit with a bottom air inlet.)

# INDOOR UNIT

## Ceiling concealed type



### PEFY-P VMS1(L)-E

<b>Static Pressure</b> 5~50Pa	<b>Height</b> 200mm 7-28/32in.	<b>Low Noise</b>	<b>Width</b> 790mm 31-1/8in.	<b>Width</b> 990mm 39in.	<b>Width</b> 1,190mm 46-7/8in.
----------------------------------	--------------------------------------	------------------	------------------------------------	--------------------------------	--------------------------------------

The ultra thin unit of 200mm offers increased flexibility, and is particularly suitable for places where low noise operation is desired from a slim line body.



#### Changeable static pressure

The unit is made suitable for a variety of applications with its four static pressure settings of 5, 15, 35, 50Pa.

#### Changeable airflow rate

Low, middle, and high fan speed settings deliver precise comfort.

#### Choice for drain pump

Drain pump is an optional part for the VMS1L, and a standard for VMS1.

\*For places where low noise operation is especially required (i.e. Hotels), VMS1L (without drain pump) is recommended.

#### PP Honeycomb fabric

Washable PP Honeycomb fabric filter as standard

#### Ultra low height unit with 200mm (7-28/32in.) high Ultra-narrow width of 790mm (P15-P32 models) [990mm for P40,50 models / 1190mm for P63 models]

Can be installed easily in tight spaces, such as ceiling cavities or drop-ceilings.

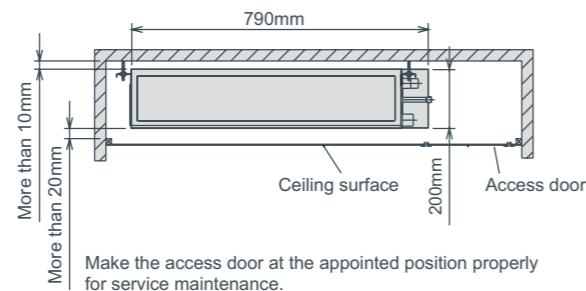

#### Reduced noise thanks to the use of newly designed centrifugal fan and coil

Sound pressure level table (Standard static pressure) at 15Pa

Sound pressure Level	Fan Speed	dB(A)							
		Capacity	P15	P20	P25	P32	P40	P50	P63
		High	28	29	30	32	33	35	36
Mid	24	25	26	27	30	32	33		
Low	22	23	24	24	28	30	30		

## Specifications

		PEFY-P15VMS1(L)-E *	PEFY-P20VMS1(L)-E	PEFY-P25VMS1(L)-E	PEFY-P32VMS1(L)-E	PEFY-P40VMS1(L)-E	PEFY-P50VMS1(L)-E	PEFY-P63VMS1(L)-E	
Power source		1-phase 220-240V 50Hz / 1-phase 220-240V 60Hz							
Cooling capacity	*1 kW	1.7	2.2	2.8	3.6	4.5	5.6	7.1	
	*1 BTU/h	5,800	7,500	9,600	12,300	15,400	19,100	24,200	
Heating capacity	*1 kW	1.9	2.5	3.2	4.0	5.0	6.3	8.0	
	*1 BTU/h	6,500	8,500	10,900	13,600	17,100	21,500	27,300	
Power consumption	*3 Cooling kW	0.05 [0.03]	0.05 [0.03]	0.06 [0.04]	0.07 [0.05]	0.07 [0.05]	0.09 [0.07]	0.09 [0.07]	
	*3 Heating kW	0.03 [0.03]	0.03 [0.03]	0.04 [0.04]	0.05 [0.05]	0.05 [0.05]	0.07 [0.07]	0.07 [0.07]	
Current	*3 Cooling A	0.42 [0.31]	0.47 [0.36]	0.50 [0.39]	0.50 [0.39]	0.56 [0.45]	0.67 [0.56]	0.72 [0.61]	
	*3 Heating A	0.31 [0.31]	0.36 [0.36]	0.39 [0.39]	0.39 [0.39]	0.45 [0.45]	0.56 [0.56]	0.61 [0.61]	
External finish		Galvanized							
Dimension		mm			200 x 790 x 700			200 x 990 x 700	
H x W x D		In.			7-7/8 x 31-1/8 x 27-9/16			7-7/8 x 39 x 27-9/16	
Net weight		*3 kg(lbs.)			19(42) [18(40)]			20(45) [19(42)]	
Heat exchanger		Cross fin (Aluminium fin and copper tube)							
Fan	Type x Quantity	Sirocco fan x 2			Sirocco fan x 3			Sirocco fan x 4	
	Airflow rate (Lo-Mid-Hi)	m <sup>3</sup> /min	5-6-7	5.5-6.5-8	5.5-7-9	6-8-10	8-9.5-11	9.5-11-13	12-14-16.5
		L/s	83-100-117	91-108-133	91-117-150	100-133-167	133-158-183	158-183-217	200-233-275
		cfm	176-212-247	194-229-282	194-247-317	212-282-353	282-335-388	335-388-459	424-494-583
Motor	External static press	Pa							
	type	DC motor							
Air filter	output	kW							
	type	PP Honeycomb fabric (washable)							
Refrigerant pipe diameter	Gas	mm(in.)						ø12.7 (ø1/2) Brazed	
	Liquid	mm(in.)						ø6.35 (ø1/4) Brazed	
Field drain pipe diameter		mm(in.)							
		O.D. 32 (1-1/4)							
Sound pressure level (Lo-Mid-Hi) (measured in anechoic room)		dB<A>		22-24-28	23-25-29	24-26-30	24-27-32	28-30-33	30-32-35

★PEFY-P15VMS1(L)-E can only be connected to YHM and YJM outdoor units.

	PEFY-P15VMS1(L)-E
PURY-P YHM, YJM	○
PUHY-P YHM, YJM	○
PUMY-P VHMA / VHMB	○
PUMY-P YHMA / YHMB	○
PQRY-P YGM	×
PQHY-P YGM	×
PQRY-P YHM	○
PQHY-P YHM	○

#### Notes:

\*1 Cooling/Heating capacity indicates the maximum value at operation under the following condition.  
Cooling : Indoor : 27°CDB./19°CWB. (81°FDB. / 66°FWB.) Outdoor : 35°CDB. (95°FDB. )  
Heating : Indoor : 20°CDB. (68°FDB.) Outdoor : 7°CDB. / 6°CWB. (45°FDB. / 43°FWB.)  
Pipe length : 7.5m (24-9/16ft) Height difference : 0m (0ft)

\*2 The external static pressure is set to 15 Pa at factory shipment.

\*3 [ ] is in case of PEFY-P15-63VMS1L-E

# INDOOR UNIT Ceiling Concealed Type

## PEFY-P VMA(L)-E

Middle Static Pressure  
**35~150Pa**  
Slim Body  
Height 250mm

With precise control of indoor temperature while operating with optimum energy usage, it offers a high-energy saving efficiency.



### Compact Indoor Units

For all models, unit height are unified to 250mm. Compared to the previous model, the height size is reduced, allowing installation in tight spaces, such as ceiling cavities or drop-ceilings.



PEFY-P VMA(L)	20	25	32	40	50	63	71	80	100	125	140
Height mm	250										
Width mm	700		900		1,100		1,400		1,600		
Depth mm	732										

### External static pressure

Five-stage external static pressure settings provide flexibility for duct extension, branching and air outlet configuration and are adjustable to meet different application conditions. Setting ranges to a maximum of 150Pa.

#### External static pressure setting

Series	20	25	32	40	50	63	71	80	100	125	140
PEFY-P VMA(L)	35/50/70/100/150Pa										



### Air Inlet

- (1) Rear inlet (2) Bottom inlet

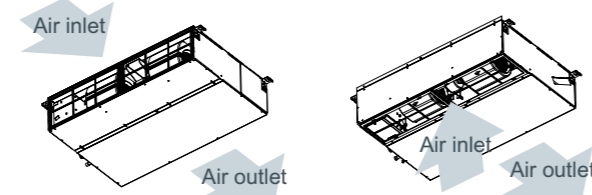

### Drain Pump Option

The line-up consists of two types, models with or without a built-in drain pump allowing more freedom in piping layout design.



PEFY-P VMA-E Drain pump built-in



PEFY-P VMA(L)-E No Drain pump

\* Units with a "L" at the end of the model name are not equipped with a drain pump.

### Analogue input

Analogue input allows unit to control the fan speed setting in conjunction with damper condition.

### IT terminal

IT terminal is available. For details, contact your local distributor.

## Specifications

		PEFY-P20VMA(L)-E	PEFY-P25VMA(L)-E	PEFY-P32VMA(L)-E	PEFY-P40VMA(L)-E	PEFY-P50VMA(L)-E	
Power source		1-phase 220-230-240V 50 / 60Hz					
Cooling capacity (Nominal)	*1 kW	2.2	2.8	3.6	4.5	5.6	
	*1 BTU/h	7,500	9,600	12,300	15,400	19,100	
Heating capacity (Nominal)	*2 kW	2.5	3.2	4.0	5.0	6.3	
	*2 BTU/h	8,500	10,900	13,600	17,100	21,500	
Power consumption	Cooling *3 kW	0.06 [0.04]	0.06 [0.04]	0.07 [0.05]	0.09 [0.07]	0.11 [0.09]	
	Heating *3 kW	0.04	0.04	0.05	0.07	0.09	
Current	Cooling *3 A	0.53 [0.42]	0.53 [0.42]	0.55 [0.44]	0.64 [0.53]	0.74 [0.63]	
	Heating *3 A	0.42	0.42	0.44	0.53	0.63	
External finish		Galvanized steel plate					
Dimension H x W x D	mm	250 x 700 x 732	250 x 700 x 732	250 x 700 x 732	250 x 900 x 732	250 x 900 x 732	
	in.	9-7/8 x 27-9/16 x 28-7/8	9-7/8 x 27-9/16 x 28-7/8	9-7/8 x 27-9/16 x 28-7/8	9-7/8 x 35-7/16 x 28-7/8	9-7/8 x 35-7/16 x 28-7/8	
Net weight	kg(lbs)	23 (51) [22 (49)]	23 (51) [22 (49)]	23 (51) [22 (49)]	26 (58) [25 (56)]	26 (58) [25 (56)]	
Heat exchanger		Cross fin (Aluminum fin and copper tube)					
Fan	Type x Quantity	Sirocco fan x 1					
	Airflow rate (Low-Mid-High)	m³/min	6.0 - 7.5 - 8.5	6.0 - 7.5 - 8.5	7.5 - 9.0 - 10.5	10.0 - 12.0 - 14.0	12.0 - 14.5 - 17.0
		L/s	100 - 125 - 142	100 - 125 - 142	125 - 150 - 175	167 - 200 - 233	200 - 242 - 283
	cfm	212 - 265 - 300	212 - 265 - 300	265 - 318 - 371	353 - 424 - 494	424 - 512 - 600	
External static pressure *4	Pa	<35> - 50 - <70> - <100> - <150>	<35> - 50 - <70> - <100> - <150>	<35> - 50 - <70> - <100> - <150>	<35> - 50 - <70> - <100> - <150>	<35> - 50 - <70> - <100> - <150>	
Motor	Type	DC motor					
	Output kW	0.085	0.085	0.085	0.085	0.085	
Air filter		PP honeycomb fabric.					
Refrigerant pipe diameter	Liquid (R410A) (R22,R407C) mm(in.)	6.35 (1/4) Brazed	6.35 (1/4) Brazed	6.35 (1/4) Brazed	6.35 (1/4) Brazed	6.35 (1/4) Brazed	
	Gas (R410A) (R22,R407C) mm(in.)	12.7 (1/2) Brazed	12.7 (1/2) Brazed	12.7 (1/2) Brazed	12.7 (1/2) Brazed	12.7 (1/2) Brazed	
Field drain pipe diameter	mm(in.)	O.D.32 (1-1/4)	O.D.32(1-1/4)	O.D.32(1-1/4)	O.D.32 (1-1/4)	O.D.32 (1-1/4)	
Sound pressure level (measured in anechoic room)							
(Low-Mid-High) *3	*5 dB(A)	26-28-29	26-28-29	28-30-34	28-30-34	28-32-35	
	*6 dB(A)	23-25-26	23-25-26	23-26-29	23-27-30	25-29-32	

		PEFY-P63VMA(L)-E	PEFY-P71VMA(L)-E	PEFY-P80VMA(L)-E	PEFY-P100VMA(L)-E	PEFY-P125VMA(L)-E	PEFY-P140VMA(L)-E	
Power source		1-phase 220-230-240V 50 / 60Hz						
Cooling capacity (Nominal)	*1 kW	7.1	8.0	9.0	11.2	14.0	16.0	
	*1 BTU/h	24,200	27,300	30,700	38,200	47,800	54,600	
Heating capacity (Nominal)	*2 kW	8.0	9.0	10.0	12.5	16.0	18.0	
	*2 BTU/h	27,300	30,700	34,100	42,700	54,600	61,400	
Power consumption	Cooling *3 kW	0.12 [0.10]	0.14 [0.12]	0.14 [0.12]	0.24 [0.22]	0.34 [0.32]	0.36 [0.34]	
	Heating *3 kW	0.10	0.12	0.12	0.22	0.32	0.34	
Current	Cooling *3 A	1.01 [0.90]	1.15 [1.04]	1.15 [1.04]	1.47 [1.36]	2.05 [1.94]	2.21 [2.10]	
	Heating *3 A	0.90	1.04	1.04	1.36	1.94	2.10	
External finish		Galvanized steel plate						
Dimension H x W x D	mm	250 x 1,100 x 732	250 x 1,100 x 732	250 x 1,100 x 732	250 x 1,400 x 732	250 x 1,400 x 732	250 x 1,600 x 732	
	in.	9-7/8 x 43-5/16 x 28-7/8	9-7/8 x 43-5/16 x 28-7/8	9-7/8 x 43-5/16 x 28-7/8	9-7/8 x 55-1/8 x 28-7/8	9-7/8 x 55-1/8 x 28-7/8	9-7/8 x 63 x 28-7/8	
Net weight	kg(lbs)	32 (71) [31(69)]	32 (71) [31 (69)]	32 (71) [31 (69)]	42 (93) [41 (91)]	42 (93) [41 (91)]	46 (102) [45 (10)]	
Heat exchanger		Cross fin (Aluminum fin and copper tube)						
Fan	Type x Quantity	Sirocco fan x 2						
	Airflow rate (Low-Mid-High)	m³/min	13.5 - 16.0 - 19.0	14.5 - 18.0 - 21.0	14.5 - 18.0 - 21.0	23.0 - 28.0 - 33.0	28.0 - 34.0 - 40.0	29.5 - 35.5 - 42.0
		L/s	225 - 267 - 317	242 - 300 - 350	242 - 300 - 350	383 - 467 - 550	467 - 567 - 667	492 - 592 - 700
	cfm	477 - 565 - 671	512 - 636 - 742	512 - 636 - 742	812 - 989 - 1,165	989 - 1,201 - 1,412	1,042 - 1,254 - 1,483	
External static pressure *4	Pa	<35> - 50 - <70> - <100> - <150>	<35> - 50 - <70> - <100> - <150>	<35> - 50 - <70> - <100> - <150>	<35> - 50 - <70> - <100> - <150>	<35> - 50 - <70> - <100> - <150>	<35> - 50 - <70> - <100> - <150>	
Motor	Type	DC motor						
	Output kW	0.121	0.121	0.121	0.244	0.244	0.244	
Air filter		PP honeycomb fabric.						
Refrigerant pipe diameter	Liquid (R410A) (R22,R407C) mm(in.)	9.52 (3/8) Brazed	9.52 (3/8) Brazed	9.52 (3/8) Brazed	9.52 (3/8) Brazed	9.52 (3/8) Brazed	9.52 (3/8) Brazed	
	Gas (R410A) (R22,R407C) mm(in.)	15.88 (5/8) Brazed	15.88 (5/8) Brazed	15.88 (5/8) Brazed	15.88 (5/8) Brazed	15.88 (5/8) Brazed	15.88 (5/8) Brazed	
Field drain pipe diameter	mm(in.)	O.D.32 (1-1/4)	O.D.32 (1-1/4)	O.D.32 (1-1/4)	O.D.32 (1-1/4)	O.D.32 (1-1/4)	O.D.32 (1-1/4)	
Sound pressure level (measured in anechoic room)								
(Low-Mid-High) *3	*5 dB(A)	29-32-36	30-34-38	30-34-38	32-37-41	35-40-44	36-41-45	
	*6 dB(A)	25-29-33	26-29-34	26-29-34	28-33-37	32-36-40	33-37-42	

### Notes:

- \* [ ] is in case of PEFY-P VMA(L)-E
- \*1 Nominal cooling conditions  
Indoor: 27°CDB/19°CWB(81°FDB/66°FWB), Outdoor: 35°CDB(95°FDB)  
Pipe length: 7.5m(24-9/16ft.), Level difference: 0m(0ft.)
- \*2 Nominal heating conditions  
Indoor: 20°CDB(68°FDB), Outdoor: 7°CDB/6°CWB(45°FDB/43°FWB)  
Pipe length: 7.5m(24-9/16ft.), Level difference: 0m(0ft.)
- \*3 The values are measured at the rated external static pressure.
- \*4 The rated external static pressure is shown without < >. The factory setting is the rated value.

- \*5 Measured in anechoic room with a 1m air inlet duct and 2m air outlet duct attached to the unit and 1.5m below the unit.

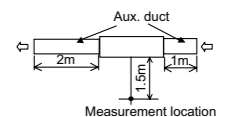

- \*6 Measured in anechoic room with a 2m air inlet duct and 2m air outlet duct attached to the unit and 1.5m below the unit.

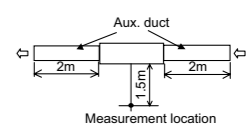

# INDOOR UNIT Ceiling concealed type

## PEFY-P VMH(S)-E

High Static Pressure

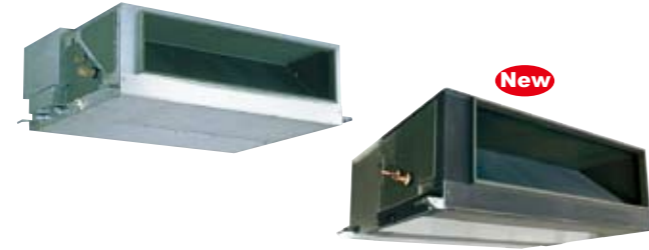

Increased design flexibility from sufficient external static pressure allows authentic duct air-conditioning with an elegant interior layout.



### High static pressure of 200 Pa or higher

The additional external static pressure capacity provides flexibility for duct extension, branching and air outlet configuration.

PEFY-P VMH-E	P40	P50	P63	P71	P80	P100	P125	P140	P200	P250	
External static pressure (Pa)	220V	50/100/200								—	—
	230/240V	100/150/200								—	—
	380V	—								110/220	—
	400/415V	—								—	130/260

PEFY-P VMHS-E	P200	P250	
External static pressure (Pa)	<50> - <100> - 150 - <200> - <250>*	—	—

\*The rated external static pressure is shown without < >.  
The factory setting is the rated value.

### Reduced noise thanks to the use of newly designed centrifugal fan

Sound pressure level table (Standard static pressure 220V)

Sound pressure level	Capacity	Fan Speed	dB(A)							
			P40	P50	P63	P71	P80	P100	P125	P140
High	Low	High	34	34	38	39	41	42	42	42
		Low	27	27	32	32	35	34	34	34

### One-side maintenance

All maintenance to the unit, including fan inspection and fan motor removal, can be conducted from the inspection opening on one side. (VMH model only)

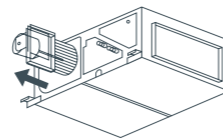

### Drain pump (option) ensures up to 550mm (21-11/16in.) for VMH model / 700mm (27-9/16in.) for VMHS model of lift

The introduction of an upper drain pump allows the drain connection to be raised as high as 550mm(21-11/16in.) for VMH model/700mm (27-9/16in.) for VMHS model, allowing more freedom in piping layout design and reducing horizontal piping requirements.

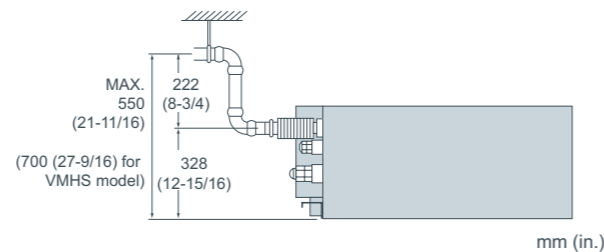

## Specifications

		PEFY-P40VMH-E	PEFY-P50VMH-E	PEFY-P63VMH-E	PEFY-P71VMH-E	PEFY-P80VMH-E	PEFY-P100VMH-E	PEFY-P125VMH-E	PEFY-P140VMH-E	
Power source		1-phase 220-240V 50Hz / 1-phase 220-240V 60Hz								
Cooling capacity	*1 kW	4.5	5.6	7.1	8.0	9.0	11.2	14.0	16.0	
	*1 BTU/h	15,400	19,100	24,200	27,300	30,700	38,200	47,800	54,600	
Heating capacity	*1 kW	5.0	6.3	8.0	9.0	10.0	12.5	16.0	18.0	
	*1 BTU/h	17,100	21,500	27,300	30,700	34,100	42,700	54,600	61,400	
Power consumption	Cooling kW	0.19 / 0.23		0.24 / 0.30	0.26 / 0.33	0.32 / 0.40	0.48 / 0.58		0.48 / 0.59	
	Heating kW	0.19 / 0.23		0.24 / 0.30	0.26 / 0.33	0.32 / 0.40	0.48 / 0.58		0.48 / 0.59	
Current	Cooling A	0.88 / 1.06		1.12 / 1.38	1.20 / 1.51	1.47 / 1.83	2.34 / 2.66		2.35 / 2.70	
	Heating A	0.88 / 1.06		1.12 / 1.38	1.20 / 1.51	1.47 / 1.83	2.34 / 2.66		2.35 / 2.70	
External finish		Galvanized								
Dimension H x W x D	mm	380 x 750 x 900			380 x 1,000 x 900		380 x 1,200 x 900			
	in.	15 x 29-9/16 x 35-7/16			15 x 39-3/8 x 35-7/16		15 x 47-1/4 x 35-7/16			
Net weight	kg(lbs.)	44 (98)	45 (100)		50 (111)		70 (155)			
Heat exchanger		Cross fin (Aluminum plate fin and copper tube)								
Fan	Type x Quantity	Sirocco fan x 1				Sirocco fan x 2				
	Airflow rate (Lo-Hi)	m³/min	10.0-14.0		13.5-19.0		15.5-22.0		18.0-25.0	
		L/s	167-233		225-317		258-367		300-417	
		cfm	353-494		477-671		547-777		636-883	
External static pressure*2	220V Pa	50 · 100 · 200								
	230,240V Pa	100 · 150 · 200								
Motor		1-phase induction motor								
Output	*3 kW	0.08		0.12	0.14	0.18	0.26			
Air filter (option)		Synthetic fiber unwoven cloth filter (long life)								
Refrigerant pipe diameter	Gas (Brazing) mm(in.)	ø12.7 (ø1/2)				ø15.88 (ø5/8)				
	Liquid (Brazing) mm(in.)	ø6.35 (ø1/4)				ø9.52 (ø3/8)				
Field drain pipe diameter		mm(in.) O.D. 32 (1-1/4)								
Sound pressure level (Lo-Hi) *6	220V dB(A)	27-34		32-38	32-39	35-41	34-42			
	230,240V dB(A)	31-37		36-41	35-41	38-43	38-44			

		PEFY-P200VMH-E	PEFY-P250VMH-E	PEFY-P200VMHS-E	PEFY-P250VMHS-E	
Power source		3-phase 380-415V 50Hz / 3N ~ 380-415V 60Hz		1-phase 220-240V 50Hz / 1-phase 220-240V 60Hz		
Cooling capacity	*1 kW	22.4	28.0	22.4	28.0	
	*1 BTU/h	76,400	95,500	76,400	95,500	
Heating capacity	*1 kW	25.0	31.5	25.0	31.5	
	*1 BTU/h	85,300	107,500	85,300	107,500	
Power consumption	Cooling kW	0.99 / 1.14		1.23 / 1.41		
	Heating kW	0.99 / 1.14		1.23 / 1.41		
Current	Cooling 380-415V A	1.62 / 1.86		2.00 / 2.30		
	220-230-240V A	—		3.47-3.32-3.18 *7		
Heating 380-415V A	380-415V A	1.62 / 1.86		2.00 / 2.30		
	220-230-240V A	—		3.47-3.32-3.18 *7		
External finish		Galvanized		Galvanized steel plate		
Dimension H x W x D	mm	470 x 1,250 x 1,120		470 x 1,250 x 1,120		
	in.	18-9/16 x 49-1/4 x 44-1/8		18-9/16 x 49-1/4 x 44-1/8		
Net weight	kg(lbs.)	100 (221)		97 (214)	100 (221)	
Heat exchanger		Cross fin (Aluminum plate fin and copper tube)		Cross fin (Aluminum plate fin and copper tube)		
Fan	Type x Quantity	Sirocco fan x 2		Sirocco fan x 2		
	Airflow rate	m³/min	58.0	72.0	—	—
		L/s	967	1200	—	—
		cfm	2048	2543	—	—
Lo-Mid-Hi	m³/min	—	—	50.0-61.0-72.0	58.0-71.0-84.0	
	L/s	—	—	833-1017-1200	967-1183-1400	
	cfm	—	—	1766-2154-2542	2048-2507-2966	
External static pressure	380V Pa	110 · 220 *4		—		
	400,415V Pa	130 · 260 *4		—		
	Pa	—		<50>-<100>-150-<200>-<250> *8		
	mmH <sub>2</sub> O	—		<5.1>-<10.2>-15.3-<20.4>-<25.5> *8		
Motor		3-phase induction motor		DC motor		
Output	kW	0.76 *5		1.08 *5	0.87	
Air filter(option)		Synthetic fiber unwoven cloth filter (long life)		Synthetic fiber unwoven cloth filter (long life filter) and filter box are recommended.		
Refrigerant pipe diameter	Gas (Brazing) mm(in.)	ø19.05 (ø3/4)		ø19.05 (ø3/4)		
	Liquid (Brazing) mm(in.)	ø22.2 (ø7/8)		ø9.52 (ø3/8)		
Field drain pipe diameter		mm(in.) O.D. 32 (1-1/4)				
Sound pressure level	380V dB(A)	42 (110Pa) / 45 (220Pa) *6		50 (110Pa) / 52 (220Pa) *6		
	400,415V dB(A)	44 (130Pa) / 47 (260Pa) *6		52 (130Pa) / 54 (260Pa) *6		
Lo-Mid-Hi	dB(A)	—		36-39-43 *9		

#### Notes:

- \*1 Cooling/heating capacity indicates the maximum value at operation under the following condition.  
Cooling Indoor : 27°C(81°F)DB/19°C(66°F)WB, Outdoor : 35°C(95°F)DB  
Heating Indoor : 20°C(68°F)DB, Outdoor : 7°C(45°F)DB/6°C(43°F)WB
- \*2 The external static pressure is set to 100Pa (at 220V) /150Pa (at 230, 240V) at factory shipment.
- \*3 The value are that at 240V.
- \*4 The external static pressure is set to 220Pa (at 380V) /260Pa (at 400, 415V) at factory shipment.
- \*5 The value are that at 415V.

- \*6 It is measured in anechoic room.
- \*7 The values are measured at the rated external static pressure.
- \*8 The rated external static pressure is shown without < >.  
The factory setting is the rated value.
- \*9 It is measured at the rated external static pressure in anechoic room.

# INDOOR UNIT Fresh Air Intake Type

## PEFY-P VMH-E-F

Fresh Air Intake

Fresh Air can be taken in with temperature control.  
Ideal for Offices, Stores and Restaurants.



The Fresh Air intake indoor unit can be installed in any place.

The Fresh Air intake indoor unit can take fresh outdoor air into any building in any place at any time.

Office, Lobby, Workshop, Rest room, Nursing home, Smoking corner, Kitchen in restaurant

\* Limits of capacity connectable to outdoor unit  
Max. 110% of outdoor unit capacity, excepting heating at outdoor temperature of less than -5°C(23°F) (100%).

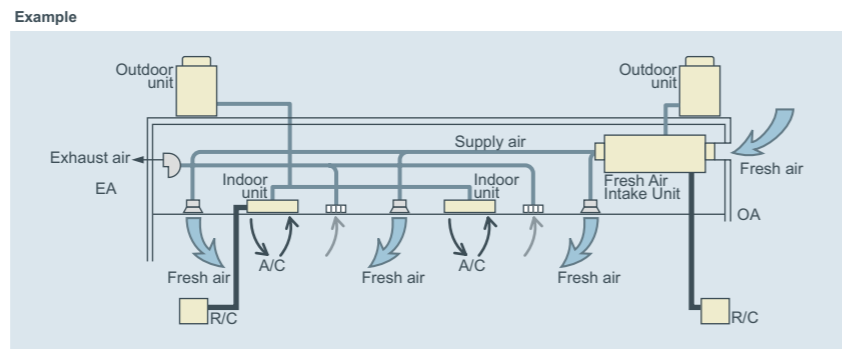

< Note >  
Fan remains in operation during Thermo-OFF. Using this model with other type of indoor unit is recommended to prevent cold draft which is caused due to intaken fresh air.

## Specifications

		PEFY-P80VMH-E-F		PEFY-P140VMH-E-F	
Power source		1-phase 220-240V 50Hz / 1-phase 208-230V 60Hz			
Cooling capacity	*1	kW	9.0		16.0
	*1	BTU/h	30,700		54,600
Heating capacity	*1	kW	8.5		15.1
	*1	BTU/h	29,000		51,500
Power consumption	Cooling	kW	0.16 / 0.21		0.29 / 0.33
	Heating	kW	0.16 / 0.21		0.29 / 0.33
Current	Cooling	A	0.67 / 0.91		1.24 / 1.48
	Heating	A	0.67 / 0.91		1.24 / 1.48
External finish		Galvanized			
Dimension H x W x D		mm(in.)		380 x 1000 x 900 (15 x 39-3/8 x 35-7/16)	
Net weight		kg(lbs.)		50 (111)	
Heat exchanger		Cross fin (Aluminum plate fin and copper tube)			
Fan	Type x Quantity		Sirocco fan x 1		Sirocco fan x 2
	Airflow rate		m <sup>3</sup> /min	9.0	18.0
			L/s	150	300
			cfm	18	636
	External static pressure (Lo-Mid-Hi)	208V	Pa	35 - 85 - 170	35 - 85 - 170
220V		Pa	40 - 115 - 190	50 - 115 - 190	
230V		Pa	50 - 130 - 210	60 - 130 - 220	
240V		Pa	80 - 170 - 220	100 - 170 - 240	
Motor		1-phase induction motor			
Output		kW		0.09 (at 220V)	0.14 (at 220V)
Air filter (option)		Synthetic fiber unwoven cloth filter (long life)			
Refrigerant pipe diameter	Gas (Flare)	mm(in.)	ø15.88 (ø5/8)		
	Liquid (Flare)	mm(in.)	ø9.52 (ø3/8)		
Field drain pipe diameter		mm(in.) O.D.32 (1-1/4)			
Sound pressure level (Lo-Mid-Hi)	208, 220V	dB(A)	27 - 38 - 43		28 - 38 - 43
	230, 240V	dB(A)	33 - 43 - 45		34 - 43 - 45

		PEFY-P200VMH-E-F		PEFY-P250 VMH-E-F	
Power source		3-phase 380-415V 50Hz / 3N- 380-415V 60Hz			
Cooling capacity	kW	22.4		28.0	
	BTU/h	76,400		95,500	
Heating capacity	kW	21.2		26.5	
	BTU/h	72,300		90,400	
Power consumption	Cooling	kW	0.34 / 0.42	0.39 / 0.50	
	Heating	kW	0.34 / 0.42	0.39 / 0.50	
Current	Cooling	A	0.58 / 0.74	0.68 / 0.86	
	Heating	A	0.58 / 0.74	0.68 / 0.86	
External finish		Galvanized			
Dimension H x W x D		mm(in.)		470 x 1250 x 1120 (18-9/16 x 49-1/4 x 44-1/8)	
Net weight		kg(lbs.)		100 (221)	
Heat exchanger		Cross fin (Aluminum plate fin and copper tube)			
Fan	Type x Quantity		Sirocco fan x 2		
	Airflow rate		m <sup>3</sup> /min	28	35
			L/s	467	583
			cfm	989	1236
	External static pressure	380V	Pa	140 / 200	110 / 190
400V		Pa	150 / 210	120 / 200	
415V		Pa	160 / 220	130 / 210	
Motor		3-phase induction motor			
Output		kW		0.20	0.23
Air filter (option)		Synthetic fiber unwoven cloth filter (long life type)			
Refrigerant pipe diameter	Gas (Flare)	mm(in.)	ø19.05 (ø3/4)		ø22.2 (ø7/8)
	Liquid (Flare)	mm(in.)	ø9.52 (ø3/8)		
Field drain pipe diameter		mm(in.) O.D.32 (1-1/4)			
Sound pressure level	380V	dB(A)	39 / 42		40 / 44
	400V	dB(A)	40 / 43		40 / 45
	415V	dB(A)	40 / 44		41 / 46

### Notes:

- The cooling and heating capacities are the maximum capacities that were obtained by operating in the above air conditions and with a refrigerant pipe of about 7.5m.
- The actual capacity characteristics vary with the combination of indoor and outdoor units. See the technical information.
- The operating noise is the data that was obtained by measuring it 1.5m from the bottom of the unit in an anechoic room. (Noise meter A-scale value)
- The figure of Electrical characteristic indicates at 240V 50Hz/230V60Hz (PEFY-P80, 140VMH-E-F type), at 220Pa setting at 415V (PEFY-P200, 250VMH-E-F type).
- When the 100% fresh air indoor units are connected, the maximum connectable outdoor units to 1 outdoor unit are as follows

Heat pump models	Cooling only
110%(100% in case of heating below-5°C(23°F))	110%

- Operational temp range is (Cooling : from 21°C(70°F)DB/15.5°C(60°F)WB to 43°C(109°F)DB/35°C(95°F)WB)  
(Heating : from -10°C(14°F)DB to 20°C(68°F)DB)

- Thermo off(Fan) operation automatically starts either when temperature is lower than 21°C(70°F)DB in cooling mode or when the temperature exceeds 20°C(68°F)DB in heating mode.
- As the room temp in sensed by the thermo in the remote controller or the one in the room, be sure to use either remote controller or room thermo.
- Autochangeover function or Dry mode is NOT available. Fan mode operation during the thermo off in Cooling/Heating mode.
- In any case, the air flow rate should be kept lower than 110% of the above chart. Please see "Fan curves" for the details.
- When this unit is used as sole A/C system, be careful about the dew in air outlet grilles in cooling mode.
- Un-conditioned outdoor air such as humid air or cold air blows to the indoor during thermo off operation. Please be careful when positioning indoor unit air outlet grilles, to take the necessary precautions for cold air, and also insulate rooms for dew condensation prevention as required.
- Air filter must be installed in the air intake side. The filter should be attached where easy maintenance is possible in case of usage of field supply filters.
- Long life cannot be used with Hi-efficiency filter together (PEFY-P80 - 140VMH-E-F type).

# INDOOR UNIT

## Ceiling suspended type

### PCFY-P VKM-E



Designed for ultra-quiet operation and easy maintenance, provides exceptionally comfortable air-conditioning.



Extra slim, extra stylish

Sleek and slim with stylishly curved lines, the PCFY series blends right into any interior. It also features a single air outlet which allows the auto vane to act as a shutter when the unit is turned off.

#### Auto vane distributes air evenly

The auto vane swings up and down automatically to distribute air more evenly to every corner of the room.

#### Long life filter as standard

Long life filter is equipped as standard enabling up to 2,500 hours of operation (office use) without maintenance.

#### Keeps airflow at optimum level according to ceiling height

The most suitable airflow can be selected for ceilings up to 4.2m high, enhancing air-conditioning efficiency and comfort. (P100/P125)

	Standard	High ceiling
Ceiling height	3.0(9-13/16)	4.2(13-3/4)

m (ft)

#### Greatly simplified installation

The direct suspension system eliminates the task of removing the attachment fixture from the main unit, greatly shortening installation time.

#### Drain pump option available with all models

The pumping height of the optional drain pump has been increased from 400 mm to 600 mm, expanding flexibility in choosing unit location during installation work.

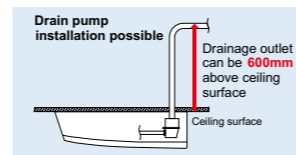

#### Outside-air intake

Units are equipped with a knock-out hole that enables the induction of fresh outside-air.

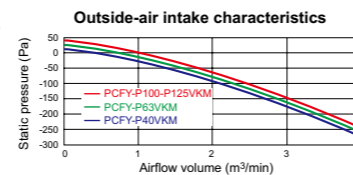

#### Equipped with automatic air-speed adjustment

In addition to the conventional 4-speed setting, units are now equipped with an automatic air-speed adjustment mode. This setting automatically adjusts the air-speed to conditions that match the room environment. At the start of heating/cooling operation, the airflow is set to high-speed to quickly heat/cool the room. When the room temperature reaches the desired setting, the airflow speed is decreased automatically for stable comfortable heating/cooling operation.

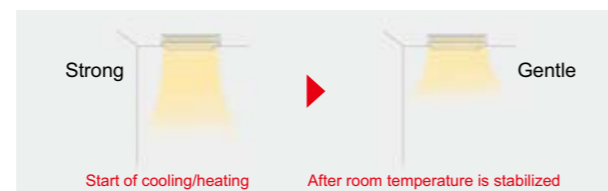

## Specifications

		PCFY-P40VKM-E	PCFY-P63VKM-E	PCFY-P100VKM-E	PCFY-P125VKM-E	
Power source		1-phase 220-240V 50Hz / 1-phase 220V 60Hz				
Cooling capacity	*1 kW	4.5	7.1	11.2	14.0	
	*1 BTU/h	15,400	24,200	38,200	47,800	
Heating capacity	*1 kW	5.0	8.0	12.5	16.0	
	*1 BTU/h	17,100	27,300	42,700	54,600	
Power consumption	Cooling kW	0.04	0.05	0.09	0.11	
	Heating kW	0.04	0.05	0.09	0.11	
Current	Cooling A	0.28	0.33	0.65	0.76	
	Heating A	0.28	0.33	0.65	0.76	
External finish(Munsell No.)		6.4Y 8.9/ 0.4				
Dimension H x W x D	mm	230 x 960 x 680	230 x 1,280 x 680	230 x 1,600 x 680		
	in.	9-1/16 x 37-13/16 x 26-3/4	9-1/16 x 50-3/8 x 26-3/4	9-1/16 x 63 x 26-3/4		
Net weight	kg(lbs.)	24(53)	32 (71)	36 (79)	38 (84)	
Heat exchanger		Cross fin (Aluminum fin and copper tube)				
Fan	Type x Quantity	Sirocco fan x 2	Sirocco fan x 3	Sirocco fan x 4		
	Airflow rate *2 (Lo-Mid2-Mid1-Hi)	m³/min	10-11-12-13	14-15-16-18	21-24-26-28	21-24-27-31
		L/s	167-183-200-217	233-250-267-300	350-400-433-467	350-400-450-517
		cfm	353-388-424-459	494-530-565-636	742-847-918-989	742-847-953-1,095
External static pressure	Pa	0				
Motor	Type	DC motor				
	Output kW	0.090	0.095	0.160		
Air filter		PP Honeycomb (long life)				
Refrigerant pipe diameter	Gas (Flare) mm(in.)	ø12.7 (ø1/2)	ø15.88 (ø5/8)	ø15.88 (ø5/8) / ø19.05 (ø3/4) (Compatible)		
	Liquid (Flare) mm(in.)	ø6.35 (ø1/4)	ø9.52 (ø3/8)			
Field drain pipe diameter		mm(in.) O.D. 26 (1)				
Sound pressure level (Lo-Mid2-Mid1-Hi) *2 *3	dB(A)	29-32-34-36	31-33-35-37	36-38-41-43	36-39-42-44	

#### Notes:

- \*1 Cooling/Heating capacity indicates the maximum value at operation under the following condition.  
Cooling Indoor : 27°C(80.6°F)DB/19°C(66.2°F)WB, Outdoor 35°C(95°F)DB  
Heating Indoor : 20°C(68°F)DB, Outdoor 7°C(44.6°F)DB/6°C(42.8°F)WB
- \*2 Airflow rate/Sound pressure level are shown in (low-middle 2-middle 1-high).
- \*3 It is measured in anechoic room.

# INDOOR UNIT Wall mounted type

## PKFY-P VBM-E PKFY-P VHM-E PKFY-P VKM-E



Elegant Design and Compact Dimensions Ideal for Offices, Stores and Residential Uses.



Capacity range

Capacity	P15	P20	P25	P32	P40	P50	P63	P100
VBM	●	●	●					
VHM				●	●	●		
VKM							●	●

### 4-way piping provides more flexibility in selecting installation sites

All piping including drainage can be connected from the rear, right, base, and left of the unit, providing much greater flexibility in piping and selecting installation site.

### Flat panel & Pure white finish

All models have changed from the grill design, adopting the flat panel layout. Pursuing a design that harmonizes with virtually any interior, the unit color has been changed from white to pure white.

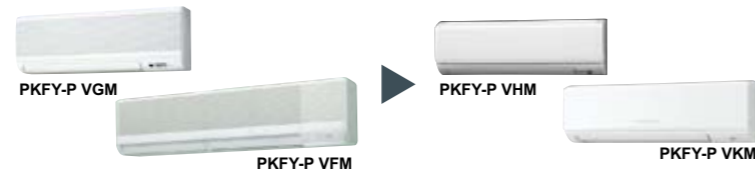

#### Built-in signal receiver

#### PKFY-P VBM features

#### Compact profile

#### Quiet operation

#### PKFY-P VHM features

#### Compact size of 898mm

Width size reduced to match small size buildings and offices.

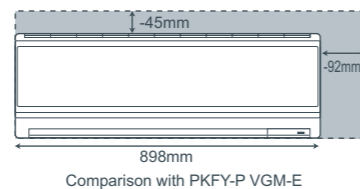

#### Light unit

Approx. 3kg reduced from conventional model (P32-50). Easier installation.

#### Drain pump (option)

The optional drain pump allows the drain connection to be raised as high as 800mm, allowing more freedom in piping layout design.

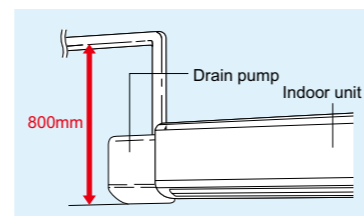

## Specifications

		PKFY-P15VBM-E	PKFY-P20VBM-E	PKFY-P25VBM-E	PKFY-P32VHM-E	PKFY-P40VHM-E	PKFY-P50VHM-E
Power source		1-phase 220-240V 50Hz / 1-phase 220V 60Hz					
Cooling capacity	*1 kW	1.7	2.2	2.8	3.6	4.5	5.6
	*1 BTU/h	5,800	7,500	9,600	12,300	15,400	19,100
Heating capacity	*1 kW	1.9	2.5	3.2	4.0	5.0	6.3
	*1 BTU/h	6,500	8,500	10,900	13,600	17,100	21,500
Power consumption	Cooling *4 kW	0.04				0.04	
	Heating kW	0.04				0.03	
Current	Cooling *4 A	0.20				0.40	
	Heating A	0.20				0.30	
External finish(Munsell No.)		Plastic (1.0Y 9.2/0.2)				Plastic (1.0Y 9.2/0.2)	
Dimension H x W x D		295 x 815 x 225 (11-5/8 x 32-1/8 x 8-7/8)			295 x 898 x 249(11-5/8 x 35-3/8 x 9-13/16)		
Net weight		10 (23)			13(29)		
Heat exchanger		Cross fin (Aluminum fin and copper tube)					
Fan	Type x Quantity	Line flow fan x 1					
	Airflow rate *2	m <sup>3</sup> /min	4.9-5.0-5.2-5.3	4.9-5.2-5.6-5.9	9-10-11	9-10.5-11.5	9-10.5-12
		L/s	82-83-87-88	82-87-93-98	150-167-183	150-175-192	150-175-200
	(Lo-Mid2-Mid1-Hi)	cfm	173-177-184-187	173-184-198-208	318-353-388	318-371-406	318-371-424
External static pressure	Pa	0					
Motor	Type	1-phase induction motor			DC motor		
	Output kW	0.017			0.030		
Air filter		PP Honeycomb					
Refrigerant pipe diameter	Gas (Flare) mm(in.)	ø12.7 (ø1/2)				ø12.7 (ø1/2) / ø15.88 (ø5/8) (Compatible)	
	Liquid (Flare) mm(in.)	ø6.35 (ø1/4)				ø6.35 (ø1/4) / ø9.52 (ø3/8) (Compatible)	
Field drain pipe diameter		mm(in.) I.D.16 (5/8)					
Sound pressure level (Lo-Mid2-Mid1-Hi) *2 *3		29-31-32-33	29-31-34-36	34-37-41	34-38-41	34-39-43	

#### Notes:

- \*1 Cooling/Heating capacity indicates the maximum value at operation under the following condition.  
Cooling Indoor : 27°C(81°F)DB/19°C(66°F)WB, Outdoor 35°C(95°F)DB  
Heating Indoor : 20°C(68°F)DB, Outdoor 7°C(45°F)DB/6°C(43°F)WB
- \*2 Airflow rate/Sound pressure level are in (low-middle2-middle1-high).
- \*3 It is measured in anechoic room.
- \*4 Electrical characteristic of cooling are included optional drain-pump.

		PKFY-P63VKM-E	PKFY-P100VKM-E	
Power source		1-phase 220-230-240V 50Hz / 1-phase 220V 60Hz		
Cooling capacity	*1 kW	7.1	11.2	
	*1 BTU/h	24,200	38,200	
Heating capacity	*1 kW	8.0	12.5	
	*1 BTU/h	27,300	42,600	
Power consumption	Cooling *4 kW	0.05	0.08	
	Heating kW	0.04	0.07	
Current	Cooling *4 A	0.37	0.58	
	Heating A	0.30	0.51	
External finish(Munsell No.)		Plastic (1.0Y 9.2/0.2)		
Dimension H x W x D		365 x 1,170 x 295 (14-3/8 x 46-1/16 x 11-5/8)		
Net weight		21 (46)		
Heat exchanger		Cross fin (Aluminum fin and copper tube)		
Fan	Type x Quantity	Line flow fan x 1		
	Airflow rate *2	m <sup>3</sup> /min	16-20	20-26
		L/s	267-333	333-433
	(Lo-Hi)	cfm	565-706	706-918
External static pressure	Pa	0		
Motor	Type	DC motor		
	Output kW	0.056		
Air filter		PP Honeycomb		
Refrigerant pipe diameter	Gas (Flare) mm(in.)	ø15.88 (ø5/8)	ø15.88 (ø5/8) / ø19.05 (ø3/4) (Compatible)	
	Liquid (Flare) mm(in.)	ø9.52 (ø3/8)		
Field drain pipe diameter		mm(in.) I.D. 16(5/8)		
Sound pressure level (Lo-Hi) *2 *3		39-45	41-49	

#### Notes:

- \*1 Cooling/heating capacity indicates the maximum value at operation under the following condition.  
Cooling Indoor : 27°C(81°F)DB/19°C(66°F)WB, Outdoor : 35°C(95°F)DB  
Heating Indoor : 20°C(68°F)DB, Outdoor : 7°C(45°F)DB/6°C(43°F)WB
- \*2 Airflow rate/Sound pressure level are in (low-high).
- \*3 It is measured in anechoic room.
- \*4 Electrical characteristic of cooling are included optional drain-pump.

# INDOOR UNIT

## Floor standing exposed

### PFFY-P VKM-E



For living rooms, bed rooms, or offices where a sophisticated design is required. The latest Mitsubishi innovation – floor-standing air-conditioner sophisticated in design, rich in function.



#### Quiet operation

Mitsubishi Electric air conditioners have always been some of the quietest models available in the market. Our new floor-standing models are no exception. It can create a silent and comfortable space where the occupants would not even recognize the existence of air conditioner operation.

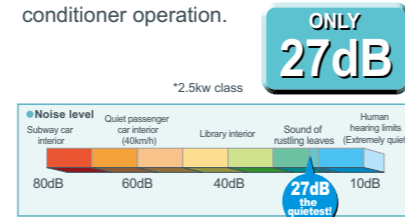

#### Sophisticated Design

From Mitsubishi Electric, an innovative new floor-standing air-conditioner. Our pleasing mix of streamlined form and diversified function.

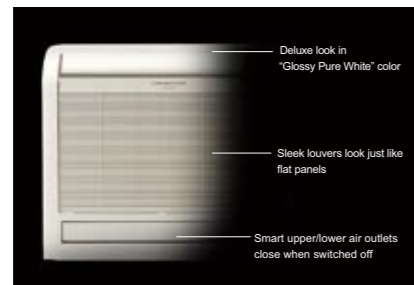

Engineered to keep room walls free, furnish comfy cooling in summer, toasty heating in winter. The "Glossy Pure White" colour ensures a deluxe look, the perfect match for any room. Both upper and lower air outlets remain closed when switched OFF, in a smart and striking image. A superb new air-conditioner from Mitsubishi, providing a handsome fit for your own distinctive interior.

#### Slim but Mighty

The unit body is slim and trim, the essence in compact. An ideal size for living rooms, bedrooms, and more. The removable and washable front panel makes cleaning a snap.

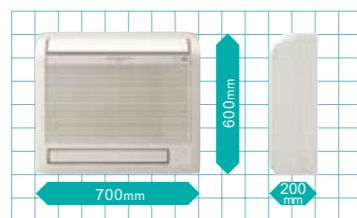

Easy and regular cleaning allows your air-conditioner stay beautiful while keeping its energy-efficient operation always possible.

#### Optimum Air Distribution

Comfy room temperatures are realized by the optimum, powerful and efficient air distribution through upper and lower air outlets. The upper vane angle is remote controllable, with 5 air flow direction levels (+Swing and Auto modes) and 4 wind power levels (+Auto mode). By setting the vane angle almost vertical, annoying direct wind can be avoided for your better comfort.



The air from both upper and lower air outlets is optimally controlled and distributed evenly to every corner of the room. In heating mode, the warm air is smartly controlled to stay at the floor level: Your feet do not feel chilled any more!

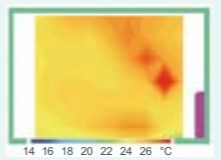

## Specifications

		PFFY-P20VKM-E	PFFY-P25VKM-E	PFFY-P32VKM-E	PFFY-P40VKM-E
Power source		1-phase 220-240V 50Hz			
Cooling capacity	*1 kW	2.2	2.8	3.6	4.5
	*1 BTU/h	7,500	9,600	12,300	15,400
Heating capacity	*1 kW	2.5	3.2	4.0	5.0
	*1 BTU/h	8,500	10,900	13,600	17,100
Power consumption	Cooling kW	0.025	0.025	0.025	0.028
	Heating kW	0.025	0.025	0.025	0.028
Current	Cooling A	0.20	0.20	0.20	0.24
	Heating A	0.20	0.20	0.20	0.24
External finish		Plastic (Pure white)			
Dimension		600 x 700 x 200			
H x W x D		23-5/8 x 27-9/16 x 7-7/8			
Net weight		15 (34)			
Heat exchanger		Cross fin (Aluminium plate fin and copper tube)			
Fan	Type x Quantity	Line flow fan x 2			
	Airflow rate (Lo-Mid-Hi-SHi) m <sup>3</sup> /min	5.9-6.8-7.6-8.7	6.1-7.0-8.0-9.1	6.1-7.0-8.0-9.1	8.0-9.0-9.5-10.7
	External static pressure Pa	0			
Motor	Type	DC motor			
	Output kW	0.03 x 2			
Air filter		PP honeycomb fabric (Catechin Filter)			
Refrigerant pipe diameter	Gas(Flare) mm(in.)	ø12.7 (ø1/2)			
	Liquid(Flare) mm(in.)	ø6.35 (ø1/4)			
Field drain pipe diameter		I.D.16 (5/8)			
Sound pressure level (Lo-Mid-Hi-SHi)	*2 dB(A)	27-31-34-37	28-32-35-38	28-32-35-38	35-38-42-44

#### Notes:

\*1 Cooling/heating capacity indicates the maximum value at operation under the following condition.  
Cooling Indoor : 27°C(81°F)DB/19°C(66°F)WB, Outdoor : 35°C(95°F)DB  
Heating Indoor : 20°C(68°F)DB, Outdoor : 7°C(45°F)DB/6°C(43°F)WB

\*2 Airflow rate/Sound pressure level are in (low-middle-high-shigh).

\*3 It is measured in anechoic room.

# INDOOR UNIT Floor standing exposed

## PFFY-P VLEM-E



Floor mounted lowboy type effective in perimeter zone.



- Standardized design with mild lines.
- Supports various types of spaces from office buildings and shop buildings to hospitals.
- Water vapor permeable film humidifier can be installed.
- Remote controller can be installed onto the main unit.

### Compact unit for easy air conditioning in perimeter zone.

The compact body of 220mm(8-11/16in.) in depth can be easily installed in the perimeter zone for effective air conditioning in the perimeter zone.

### Electronics dry function dehumidify refreshingly.

Optimum dehumidification depending on indoor temperature to prevent over-cooling. Refreshing dehumidification can be attained.

## Specifications

		PFFY-P20VLEM-E	PFFY-P25VLEM-E	PFFY-P32VLEM-E	PFFY-P40VLEM-E	PFFY-P50VLEM-E	PFFY-P63VLEM-E
Power source		1-phase 220-240V 50Hz / 1-phase 208-230V 60Hz					
Cooling capacity	*1 kW	2.2	2.8	3.6	4.5	5.6	7.1
	*1 BTU/h	7,500	9,600	12,300	15,400	19,100	24,200
Heating capacity	*1 kW	2.5	3.2	4.0	5.0	6.3	8.0
	*1 BTU/h	8,500	10,900	13,600	17,100	21,500	27,300
Power consumption	Cooling kW	0.04 / 0.06		0.06 / 0.07	0.065 / 0.075	0.085 / 0.09	0.1 / 0.11
	Heating kW	0.04 / 0.06		0.06 / 0.07	0.065 / 0.075	0.085 / 0.09	0.1 / 0.11
Current	Cooling A	0.19 / 0.25		0.29 / 0.30	0.32 / 0.33	0.40 / 0.41	0.46 / 0.47
	Heating A	0.19 / 0.25		0.29 / 0.30	0.32 / 0.33	0.40 / 0.41	0.46 / 0.47
External finish(Munsell No.)		Acrylic paint (5Y 8/1)					
Dimension H x W x D	mm	630 x 1,050 x 220		630 x 1,170 x 220		630 x 1,410 x 220	
	in.	24-13/16 x 41-3/8 x 8-11/16		24-13/16 x 46-1/8 x 8-11/16		24-13/16 x 55-9/16 x 8-11/16	
Net weight		23 (51)		25 (56)	26 (58)	30 (67)	32 (71)
Heat exchanger		Cross fin (Aluminum plate fin and copper tube)					
Fan	Type x Quantity	Sirocco fan x 1			Sirocco fan x 2		
	Airflow rate (Lo-Hi)	*2 m <sup>3</sup> /min	5.5-6.5	7.0-9.0	9.0-11.0	12.0-14.0	12.0-15.5
		L/s	92-108	117-150	150-183	200-233	200-258
	External static pressure	*2 cfm	194-230	247-318	318-388	424-494	424-547
		Pa	0				
Motor	Type	1-phase induction motor					
	Output	0.015		0.018	0.030	0.035	0.050
Air filter		PP Honeycomb fabric (washable)					
Refrigerant pipe diameter	Gas (Flare)	mm(in.) ø12.7 (ø1/2)					ø15.88 (ø5/8)
	Liquid (Flare)	mm(in.) ø6.35 (ø1/4)					ø9.52 (ø3/8)
Field drain pipe diameter		mm(in.) I.D.26 (1) <Accessory hose O.D.27 (1-3/32) (top end :20 (13/16))>					
Sound pressure level (Lo-Hi)		*2 *3 *4	34-40		35-40	38-43	40-46

### Notes:

- \*1 Cooling/Heating capacity indicates the maximum value at operation under the following condition.  
Cooling Indoor : 27°C(81°F)DB/19°C(66°F)WB, Outdoor 35°C(95°F)DB  
Heating Indoor : 20°C(68°F)DB, Outdoor 7°C(45°F)DB/6°C(43°F)WB
- \*2 Air flow rate/Sound pressure level are in (Low-High)
- \*3 Measured point : 1m x 1m, Power supply : AC240V/50Hz  
· 1dB(A) lower at AC230V/50Hz  
· 2dB(A) lower at AC220V/50Hz  
· 3dB(A) lower at 1.5m x 1.5m point
- \*4 It is measured in anechoic room.

# INDOOR UNIT

## Floor mounted concealed type

### PFFY-P VLRM-E

### PFFY-P VLRMM-E



Neatly installed with pericover concealed.  
Easy installation in perimeter zone.

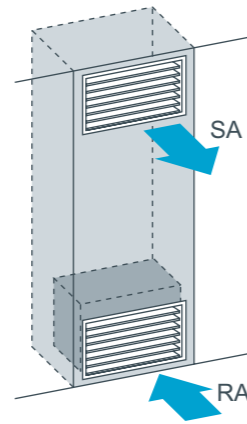

installation image  
(PFFY-P VLRMM-E)

#### Compact unit for easy air conditioning in perimeter zone.

The body is concealed in the pericover to pursue harmony with the interior.  
The compact body of 220mm(8-11/16in.) in depth can be easily installed in the perimeter zone.

#### Electronics dry function dehumidify refreshingly to prevent over-cooling.

Optimum dehumidification depending on indoor temperature to prevent over-cooling.  
Refreshing dehumidification can be attained.

#### Maximum external static pressure 60Pa (VLRMM model)

The additional external static pressure capacity provides flexibility for duct extension, branching, and air outlet configuration.

## Specifications

		PFFY-P20VLRM-E	PFFY-P25VLRM-E	PFFY-P32VLRM-E	PFFY-P40VLRM-E	PFFY-P50VLRM-E	PFFY-P63VLRM-E
Power source		1-phase 220-240V 50Hz / 1-phase 208-230V 60Hz					
Cooling capacity	*1 kW	2.2	2.8	3.6	4.5	5.6	7.1
	*1 BTU/h	7,500	9,600	12,300	15,400	19,100	24,200
Heating capacity	*1 kW	2.5	3.2	4.0	5.0	6.3	8.0
	*1 BTU/h	8,500	10,900	13,600	17,100	21,500	27,300
Power consumption	Cooling kW	0.04 / 0.06		0.06 / 0.07	0.065 / 0.075	0.085 / 0.09	0.1 / 0.11
	Heating kW	0.04 / 0.06		0.06 / 0.07	0.065 / 0.075	0.085 / 0.09	0.1 / 0.11
Current	Cooling A	0.19 / 0.25		0.29 / 0.30	0.32 / 0.33	0.40 / 0.41	0.46 / 0.47
	Heating A	0.19 / 0.25		0.29 / 0.30	0.32 / 0.33	0.40 / 0.41	0.46 / 0.47
External finish(Munsell No.)		Galvanized steel plate					
Dimension H x W x D	mm	639 x 886 x 220		639 x 1,006 x 220		639 x 1,246 x 220	
	in.	25-3/16 x 34-15/16 x 8-11/16		25-3/16 x 39-5/8 x 8-11/16		25-3/16 x 49-1/16 x 8-11/16	
Net weight		kg(lbs.) 18.5 (41)		20 (45)	21 (47)	25 (56)	27 (60)
Heat exchanger		Cross fin (Aluminum plate fin and copper tube)					
Fan	Type x Quauity	Sirocco fan x 1			Sirocco fan x 2		
	Airflow rate (Lo-Hi)	*2 m³/min	5.5-6.5	7.0-9.0	9.0-11.0	12.0-14.0	12.0-15.5
		L/s	92-108	117-150	150-183	200-233	200-258
		cfm	194-230	247-318	318-388	424-494	424-547
External static pressure		Pa 0					
Motor	Type	1-phase induction motor					
	Output	kW 0.015		0.018	0.030	0.035	0.050
Air filter		PP Honeycomb fabric (washable)					
Refrigerant pipe diameter	Gas (Flare) mm(in.)	ø12.7 (ø1/2)					ø15.88 (ø5/8)
	Liquid (Flare) mm(in.)	ø6.35 (ø1/4)					ø9.52 (ø3/8)
Field drain pipe diameter		mm(in.) I.D.26 (1) <Accessory hose O.D.27 (1-3/32) (top end :20 (13/16))>					
Sound pressure level (Lo-Hi) *2 *3 *4		dB(A) 34-40		35-40	38-43	40-46	

#### Notes:

- \*1 Cooling/Heating capacity indicates the maximum value at operation under the following condition.  
Cooling Indoor : 27°C(81°F)DB/19°C(66°F)WB, Outdoor 35°C(95°F)DB  
Heating Indoor : 20°C(68°F)DB, Outdoor 7°C(45°F)DB/6°C(43°F)WB
- \*2 Air flow rate/Sound pressure level are in (Low-High)
- \*3 Measured point : 1m x 1m, Power supply : AC240V/50Hz  
· 1dB(A) lower at AC230V/50Hz  
· 2dB(A) lower at AC220V/50Hz  
· 3dB(A) lower at 1.5m x 1.5m point
- \*4 It is measured in anechoic room.

		PFFY-P20VLRMM-E	PFFY-P25VLRMM-E	PFFY-P32VLRMM-E	PFFY-P40VLRMM-E	PFFY-P50VLRMM-E	PFFY-P63VLRMM-E
Power source		1-phase 220-240V 50Hz / 1-phase 220-240V 60Hz					
Cooling capacity	*1 kW	2.2	2.8	3.6	4.5	5.6	7.1
	*1 BTU/h	7,500	9,600	12,300	15,400	19,100	24,200
Heating capacity	*1 kW	2.5	3.2	4.0	5.0	6.3	8.0
	*1 BTU/h	8,500	10,900	13,600	17,100	21,500	27,300
Power consumption	Cooling kW	0.04		0.04	0.05	0.05	0.07
	Heating kW	0.04		0.04	0.05	0.05	0.07
Current	Cooling A	0.34		0.38	0.43	0.48	0.59
	Heating A	0.34		0.38	0.43	0.48	0.59
External finish(Munsell No.)		Galvanized steel plate					
Dimension H x W x D	mm	639 x 886 x 220		639 x 1,006 x 220		639 x 1,246 x 220	
	in.	25-3/16 x 34-15/16 x 8-11/16		25-3/16 x 39-5/8 x 8-11/16		25-3/16 x 49-1/16 x 8-11/16	
Net weight		kg(lbs.) 18.5 (41)		20 (45)	21 (47)	25 (56)	27 (60)
Heat exchanger		Cross fin (Aluminum plate fin and copper tube)					
Fan	Type x Quauity	Sirocco fan x 1			Sirocco fan x 2		
	Airflow rate (Lo-Mid-Hi)	m³/min	4.5-5.5-6.5	6.5-7.5-9.0	8.0-9.5-11.0	10.0-12.0-14.0	11.0-13.0-15.5
		L/s	75-92-108	108-125-150	133-158-183	167-200-233	183-217-258
		cfm	159-194-230	230-265-318	282-335-388	353-424-494	388-459-547
External static pressure *2		Pa 20/40/60					
Motor	Type	DC motor					
	Output	kW 0.096					
Air filter		PP Honeycomb fabric (washable)					
Refrigerant pipe diameter	Gas mm(in.)	ø12.7 (ø1/2) Brazed					ø15.88 (ø5/8) Brazed
	Liquid mm(in.)	ø6.35 (ø1/4) Brazed					ø9.52 (ø3/8) Brazed
Field drain pipe diameter		mm(in.) I.D.26 (1) <Accessory hose O.D.27 (1-3/32) (top end :20 (13/16))>					
Sound pressure level (Lo-Mid-Hi)	20Pa	dB(A) 31-36-40		27-32-37	30-36-40	32-37-41	35-40-44
	40Pa	dB(A) 34-39-42		30-35-41	32-38-42	35-40-44	36-42-47
	*3 60Pa	dB(A) 35-40-43		32-37-42	35-39-44	36-41-45	38-43-48

#### Notes:

- \*1 Cooling/Heating capacity indicates the maximum value at operation under the following condition.  
Cooling Indoor : 27°C(81°F)DB/19°C(66°F)WB, Outdoor 35°C(95°F)DB  
Heating Indoor : 20°C(68°F)DB, Outdoor 7°C(45°F)DB/6°C(43°F)WB  
pipe length : 7.5m(24-9/16ft) Height difference : 0m(0ft)
- \*2 The external static pressure is set to 20Pa at factory shipment.
- \*3 The sound pressure level in operation is measured at 1m apart from the front side and the bottom side of the unit in anechoic room.  
(Noise meter A-scale value) Connect the duct of 1m in length to the air outlet.

# BC CONTROLLER

## CMB-P-V-G1 CMB-P-V-GA1 CMB-P-V-HA1 CMB-P-V-GB1 CMB-P-V-HB1

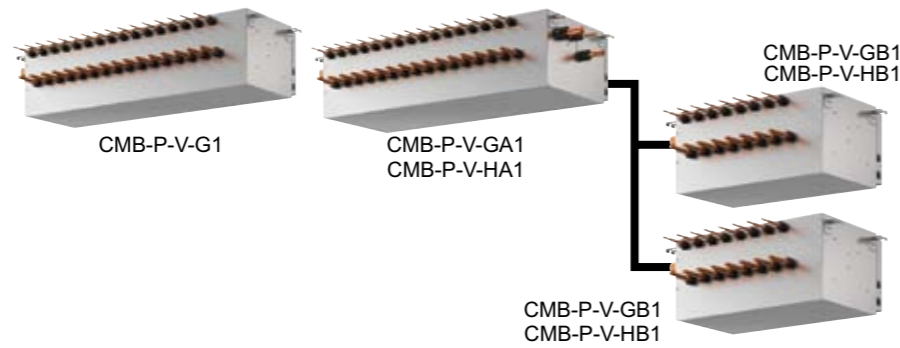

### BC CONTROLLER

In many ways, the BC Controller is the technological heart of the CITY MULTI R2/WR2. It works in unison with the outdoor unit to provide simultaneous cooling and heating, something no other two-pipe system can do. The BC Controller is connected to the outdoor unit by two pipes and to each indoor unit by a series of two refrigerant pipes, depending on the indoor unit count. The BC Controller is required for all CITY MULTI R2-Series installations. It comes in 4, 5, 6, 8, 10, 13, and 16-branch options. The BC Controller you select depends on how many indoor units will be operated from each outdoor unit and your total capacity requirements.

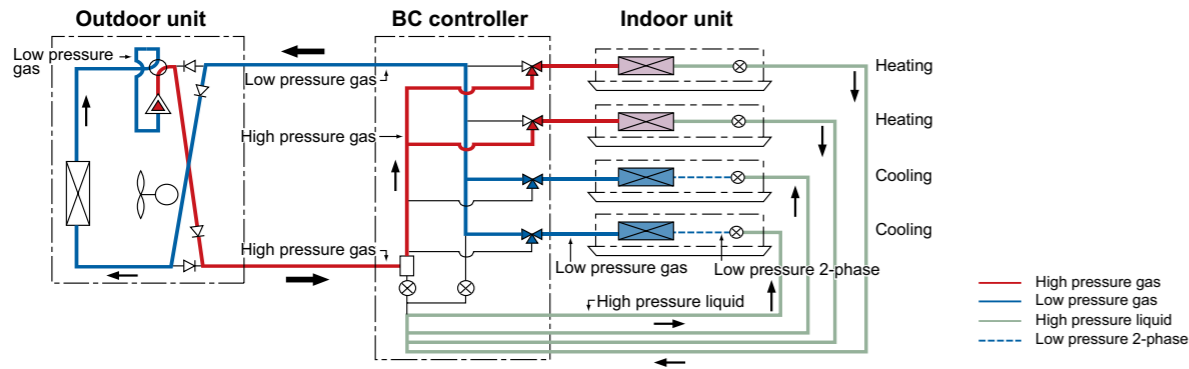

### Specifications

Model name	CMB-P104V-G1	CMB-P105V-G1	CMB-P106V-G1	CMB-P108V-G1	CMB-P1010V-G1	CMB-P1013V-G1	CMB-P1016V-G1			
Number of branch	4	5	6	8	10	13	16			
Power source	1-phase 220/230/240V 50Hz/60Hz									
Power input	kW	50Hz	Cooling	0.067/0.076/0.085	0.082/0.093/0.104	0.097/0.110/0.123	0.127/0.144/0.161	0.156/0.177/0.198	0.201/0.228/0.255	0.246/0.279/0.312
			heating	0.030/0.034/0.038	0.038/0.043/0.048	0.045/0.051/0.057	0.060/0.068/0.076	0.075/0.085/0.095	0.097/0.110/0.123	0.119/0.135/0.151
		60Hz	Cooling	0.054/0.061/0.067	0.066/0.074/0.082	0.078/0.088/0.097	0.102/0.115/0.127	0.126/0.141/0.156	0.162/0.182/0.201	0.198/0.222/0.246
			heating	0.024/0.027/0.030	0.030/0.034/0.038	0.036/0.041/0.045	0.048/0.054/0.060	0.060/0.068/0.075	0.078/0.088/0.097	0.096/0.108/0.119
Current	A	50Hz	Cooling	0.31/0.34/0.36	0.38/0.41/0.44	0.45/0.48/0.52	0.58/0.63/0.68	0.71/0.77/0.83	0.92/1.00/1.07	1.12/1.22/1.30
			heating	0.14/0.15/0.16	0.18/0.19/0.20	0.21/0.23/0.24	0.28/0.30/0.32	0.35/0.37/0.40	0.45/0.48/0.52	0.55/0.59/0.63
		60Hz	Cooling	0.25/0.27/0.28	0.30/0.33/0.35	0.36/0.39/0.41	0.47/0.50/0.53	0.58/0.62/0.65	0.74/0.80/0.84	0.90/0.97/1.03
			heating	0.11/0.12/0.13	0.14/0.15/0.16	0.17/0.18/0.19	0.22/0.24/0.25	0.28/0.30/0.32	0.36/0.39/0.41	0.44/0.47/0.50
External finish	Galvanized steel plate (Lower part drain pan painting N1.5)									
Indoor unit capacity connectable to 1 branch	Model P80 or smaller (*Use optional joint pipe combing 2 branches when the total unit capacity exceeds 81.)									
Connectable Outdoor unit ★	Refer to the combination chart of BC controller R2/WR2 series									
Height	mm	284					284			
Width	mm	648					1098			
Depth	mm	432					432			
Refrigerant piping diameter	To outdoor unit	Connectable outdoor unit capacity								
		P200		P250, P300		P350				
		High pressure pipe	ø15.88 (ø5/8) Brazed		ø19.05 (ø3/4) Brazed		ø19.05 (ø3/4) Brazed			
		Low pressure pipe	ø19.05 (ø3/4) Brazed		ø22.2 (ø7/8) Brazed		ø28.58 (ø1-1/8) Brazed			
To indoor unit	Liquid pipe	Indoor unit Model 50 or smaller: ø6.35 brazed, Over 50: ø9.52 brazed (ø12.7 with optional joint pipe used.)								
	Gas pipe	Indoor unit Model 50 or smaller: ø12.7 brazed, Over 50: ø15.88 brazed (ø19.05 with optional joint pipe used.)								
	To another BC controller	High press gas pipe	ø15.88 (ø5/8) Brazed		ø19.05 (ø3/4) Brazed		ø22.2 (ø7/8) Brazed			
		Low press gas pipe	ø19.05 (ø3/4) Brazed		ø22.2 (ø7/8) Brazed		ø28.58 (ø1-1/8) Brazed			
Drain pipe	O.D. 32mm									
Net weight	kg	24	27	28	33	38	45	52		
Accessories	*Drain connection pipe (with flexible hose and insulation) *Reducer									

### Specifications

Model name	CMB-P108V-GA1	CMB-P1010V-GA1	CMB-P1013V-GA1	CMB-P1016V-GA1	CMB-P1016V-HA1				
Number of branch	8	10	13	16					
Power source	1-phase 220/230/240V 50Hz/60Hz								
Power input	kW	50Hz	Cooling	0.127/0.144/0.161	0.156/0.177/0.198	0.201/0.228/0.255	0.246/0.279/0.312		
			heating	0.060/0.068/0.076	0.075/0.085/0.095	0.097/0.110/0.123	0.119/0.135/0.151		
		60Hz	Cooling	0.102/0.115/0.127	0.126/0.141/0.156	0.162/0.182/0.201	0.198/0.222/0.246		
			heating	0.048/0.054/0.060	0.060/0.068/0.075	0.078/0.088/0.097	0.096/0.108/0.119		
Current	A	50Hz	Cooling	0.58/0.63/0.68	0.71/0.77/0.83	0.92/1.00/1.07	1.12/1.22/1.30		
			heating	0.28/0.30/0.32	0.35/0.37/0.40	0.45/0.48/0.52	0.55/0.59/0.63		
		60Hz	Cooling	0.47/0.50/0.53	0.58/0.62/0.65	0.74/0.80/0.84	0.90/0.97/1.03		
			heating	0.22/0.24/0.25	0.28/0.30/0.32	0.36/0.39/0.41	0.44/0.47/0.50		
External finish	Galvanized steel plate (Lower part drain pan painting N1.5)								
Indoor unit capacity connectable to 1 branch	Model P80 or smaller (*Use optional joint pipe combing 2 branches when the total unit capacity exceeds 81.)								
Connectable Outdoor unit ★	Refer to the combination chart of BC controller R2/WR2 series								
Height	mm	289							
Width	mm	1,110							
Depth	mm	520							
Refrigerant piping diameter	To outdoor unit	Connectable outdoor unit capacity							
		P200		P250,300		P350	P400-P500	P550-P650	P700-P800/P850-P900*
		High pressure pipe	ø15.88 (ø5/8) Brazed		ø19.05 (ø3/4) Brazed		ø22.2 (ø7/8) Brazed		ø28.58 (ø1-1/8) Brazed/ ø28.58 (ø1-1/8) Brazed
		Low pressure pipe	ø19.05 (ø3/4) Brazed		ø22.2 (ø7/8) Brazed		ø28.58 (ø1-1/8) Brazed		
To indoor unit	Liquid pipe	Indoor unit Model 50 or smaller: ø6.35 brazed, Over 50: ø9.52 brazed (ø12.7 with optional joint pipe used.)							
	Gas pipe	Indoor unit Model 50 or smaller: ø12.7 brazed, Over 50: ø15.88 brazed (ø19.05 with optional joint pipe used.)							
To another BC controller	High press gas pipe	ø15.88 (ø5/8) Brazed		ø19.05 (ø3/4) Brazed		ø22.2 (ø7/8) Brazed			
	Low press gas pipe	ø19.05 (ø3/4) Brazed		ø22.2 (ø7/8) Brazed		ø28.58 (ø1-1/8) Brazed			
	Liquid pipe	ø9.52 (ø3/8) Brazed		ø12.7 (ø1/2) Brazed		ø15.88 (ø5/8) Brazed			
	Drain pipe	O.D. 32mm							
Net weight	kg	43	48	55	62	69			
Accessories	*Drain connection pipe (with flexible hose and insulation) *Reducer								

Model name	CMB-P104V-GB1	CMB-P108V-GB1	CMB-P1016V-HB1			
Number of branch	4	8	16			
Power source	1-phase 220/230/240V 50Hz/60Hz					
Power input	kW	50Hz	Cooling	0.060/0.068/0.076	0.119/0.135/0.151	0.237/0.269/0.301
			heating	0.030/0.034/0.038	0.060/0.068/0.076	0.119/0.135/0.151
		60Hz	Cooling	0.048/0.054/0.060	0.096/0.108/0.119	0.192/0.216/0.237
			heating	0.024/0.027/0.030	0.048/0.054/0.060	0.096/0.108/0.120
Current	A	50Hz	Cooling	0.28/0.30/0.32	0.55/0.59/0.63	1.08/1.17/1.26
			heating	0.14/0.15/0.16	0.28/0.30/0.32	0.55/0.59/0.63
		60Hz	Cooling	0.22/0.24/0.25	0.44/0.47/0.50	0.88/0.94/0.99
			heating	0.11/0.12/0.13	0.22/0.24/0.25	0.44/0.47/0.50
External finish	Galvanized steel plate (Lower part drain pan painting N1.5)					
Indoor unit capacity connectable to 1 branch	Model P80 or smaller (*Use optional joint pipe combing 2 branches when the total unit capacity exceeds 81.)					
Connectable Outdoor unit ★	Refer to the combination chart of BC controller R2/WR2 series					
Height	mm	284				
Width	mm	648				
Depth	mm	432				
Refrigerant piping diameter	To Main BC controller	Total indoor unit capacity connected this Sub BC controller				
		~P200		~P200, P201~P350		
		High pressure pipe	ø15.88 (ø5/8) Brazed			
		Low pressure pipe	ø19.05 (ø3/4) Brazed			
To indoor unit	Liquid pipe	Indoor unit Model 50 or smaller: ø6.35 brazed, Over 50: ø9.52 brazed (ø12.7 with optional joint pipe used.)				
	Gas pipe	Indoor unit Model 50 or smaller: ø12.7 brazed, Over 50: ø15.88 brazed (ø19.05 with optional joint pipe used.)				
Drain pipe	O.D. 32mm					
Net weight	kg	22	55			
Accessories	*Drain connection pipe (with flexible hose and insulation) *Reducer					

#### ★ Combination chart of BC Controller for R2 series

	P200,250,300,350	P400-650	P700-900
CMB-P V-G1	○	X	X
CMB-P V-GA1	○	○	X
CMB-P V-HA1	X	X	○
CMB-P V-GB1	○	○	○
CMB-P V-HB1	○	○	○

#### ★ Combination chart of BC Controller for WR2 series

	P200,250,300	P400,450,500,550,600
CMB-P V-G1	○	X
CMB-P V-GA1	○	○
CMB-P V-HA1	X	X
CMB-P V-GB1	○	○
CMB-P V-HB1	○	○

#### Notes:

- The equipment is for R410A refrigerant.
- Install this product in a location where noise (refrigerant noise) emitted by the unit will not disturb the neighbors. (For use in quiet environments with low background noise, position the BC CONTROLLER at least 5 m away from any indoor units.)
- Indoor units P100, P125, P140 can be connected to 1 branch. (In this case, cooling capacity decrease a little.)
- When using an outdoor unit – 28HP (P700) or more, use CMB-P1016V-HA1.
- For sub BC controller CMB-P-B-GB1 the connectable indoor unit capacities may sum to equal that of a P350 unit or less. However, if two sub controllers are used the TOTAL sum of connectable units connected to BOTH sub controllers must also not exceed that a P350 unit. For sub BC controller CMB-P-1016V-HB1 the connectable indoor unit capacities may sum to equal that of a P350 unit or less. However, if two sub controllers are used the TOTAL sum of connectable units connected to BOTH sub controllers must also not exceed that a P450 unit.

# RX5 SERIES



## The Ventilation System for Enhanced Air Quality - Lossnay

Combine with Lossnay Ventilation System Enhanced Air Quality.  
Unified Control System Allows Greater Design Freedom.

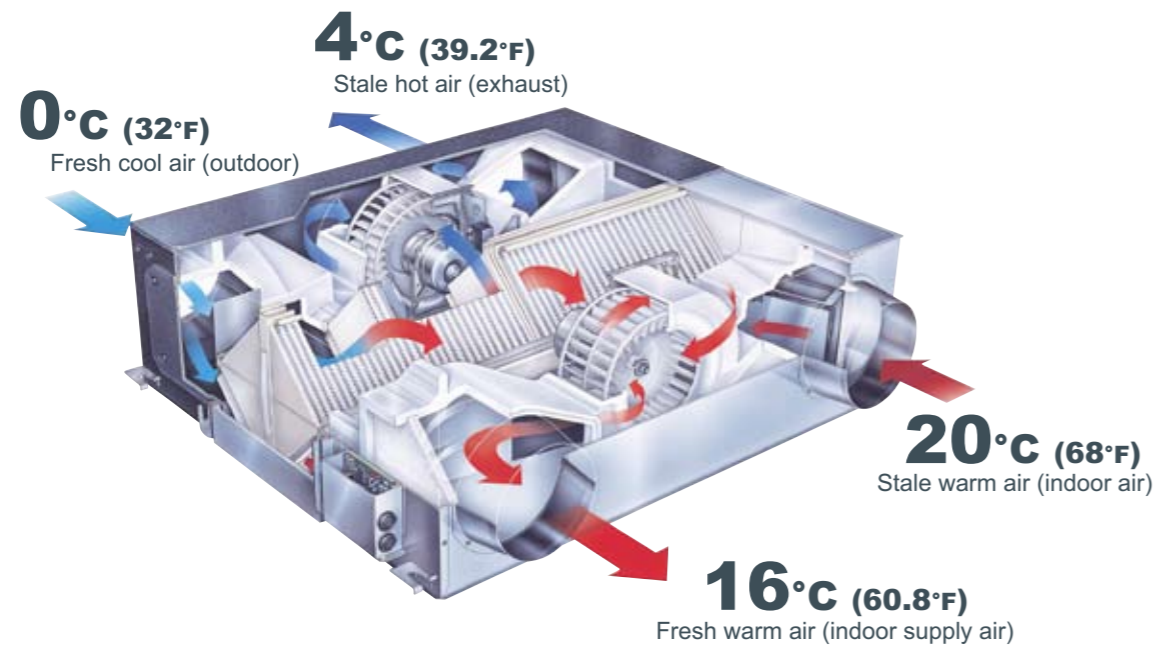

- LGH-15RX5 [150m<sup>3</sup>/h Single phase 220-240V 50Hz]
- LGH-25RX5 [250m<sup>3</sup>/h Single phase 220-240V 50Hz]
- LGH-35RX5 [350m<sup>3</sup>/h Single phase 220-240V 50Hz]
- LGH-50RX5 [500m<sup>3</sup>/h Single phase 220-240V 50Hz]
- LGH-65RX5 [650m<sup>3</sup>/h Single phase 220-240V 50Hz]

- LGH-80RX5 [800m<sup>3</sup>/h Single phase 220-240V 50Hz]
- LGH-100RX5 [1000m<sup>3</sup>/h Single phase 220-240V 50Hz]
- LGH-150RX5 [1500m<sup>3</sup>/h Single phase 220-240V 50Hz]
- LGH-200RX5 [2000m<sup>3</sup>/h Single phase 220-240V 50Hz]

### Heat-Exchange Efficiency Obtainable Only with Lossnay.

The secret to the unmatched comfort provided by Lossnay core is the cross-flow, plate-fin structure off the heat-exchange unit. A diaphragm made of a specially processed paper fully separates inducted and exhausted air supplies, ensuring that only fresh air is introduced to the indoor environment. The superior heat-transfer and moisture permeability of the special paper assure highly effective total heat exchange (temperature and humidity) when inducted and exhausted air supplies cross in the Lossnay core.

## LOSSNAY Technology

- **Two paths ventilation**  
LOSSNAY simultaneously intakes Fresh Air and exhausts Dirty Air.
- **Total energy recover**  
LOSSNAY returns BOTH sensible heat and latent heat.

### A. Two paths ventilation

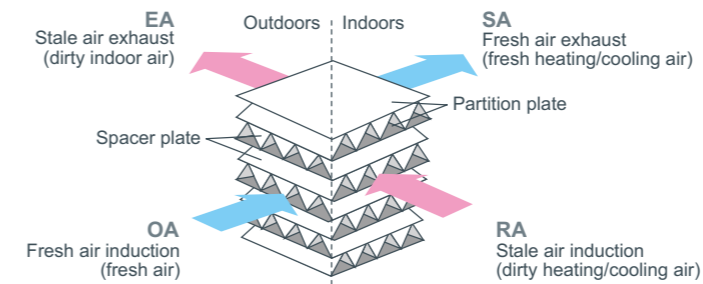

### B. Total Energy transfer

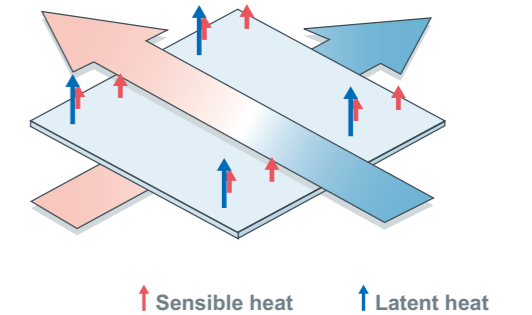

### • Hyper Eco Core

Better energy conservation by improved total heat exchange efficiency.

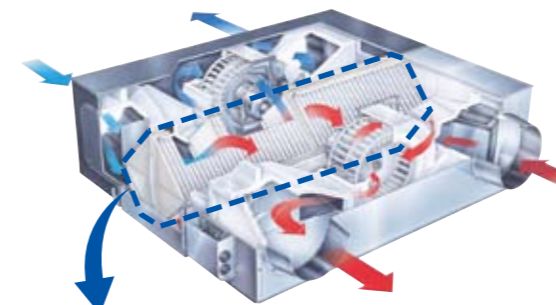

Introducing the new Hyper Eco Element  
Mitsubishi's newly developed Hyper Eco Element is on board, offering the industry's best total heat exchange efficiency. Energy conservation performance has been improved not only by reducing the air conditioning load associated with ventilation, but also by facilitating humidity penetration.

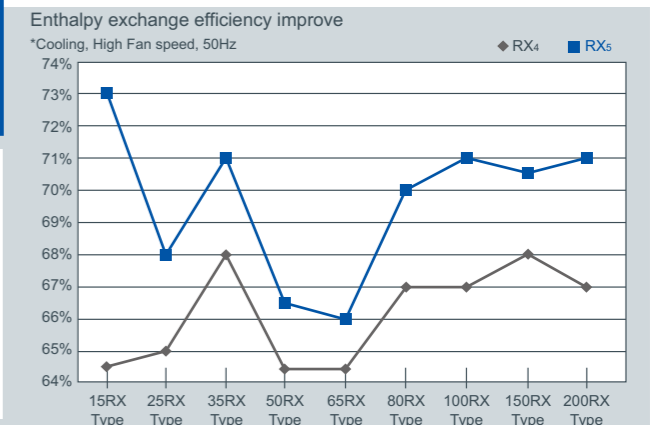
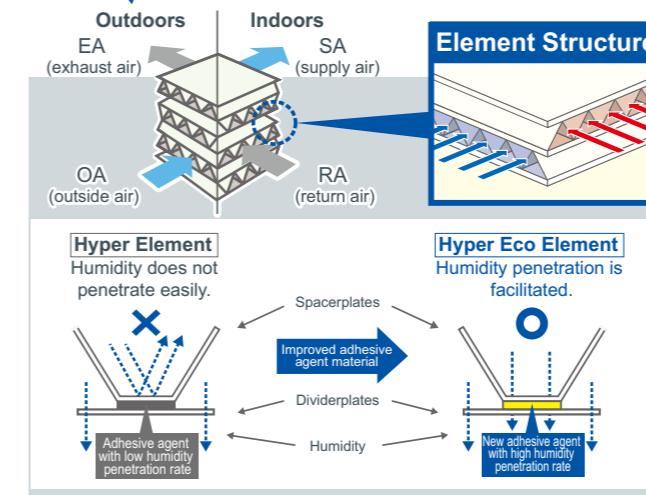

## Why LOSSNAY is necessary.

- **Without ventilation...**  
Lack of Ventilation makes people sick by dirty indoor air including CO<sub>2</sub>, Dust, Bacteria.
- **If just opening windows...**  
Opening windows eliminates dirty air BUT wastes much air-con energy.
- **So we recommend LOSSNAY**  
LOSSNAY is simultaneous pursuit of Ventilation and Energy Saving.

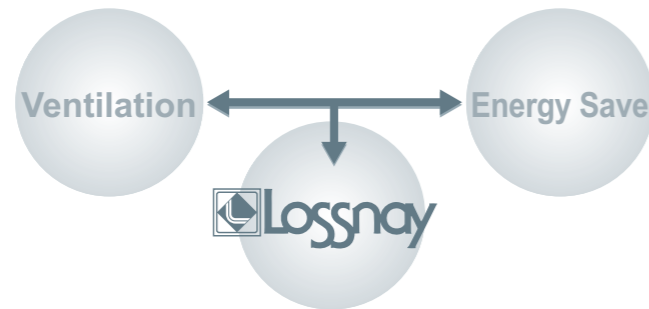

### • This is LOSSNAY !

#### ADVANTAGES

- **Clean air supply, dirty air exhaust** by Two air paths (OA → SA and RA → EA)
- **Energy recovery** by LOSSNAY Core
- **Free cooling** by bypass damper
- **MULTI VENTILATION MODE** for multi ventilation request (Power supply, Power supply/exhaust, Power exhaust)

#### UNIT STRUCTURE

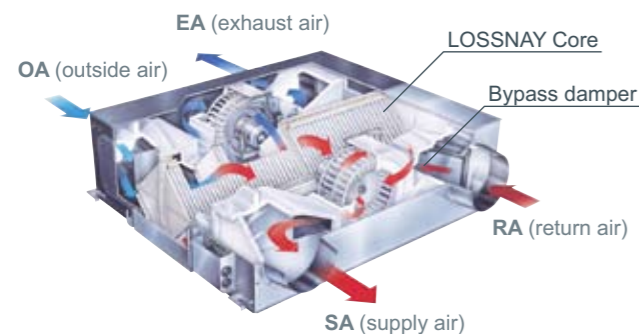

#### Energy Recovery Image

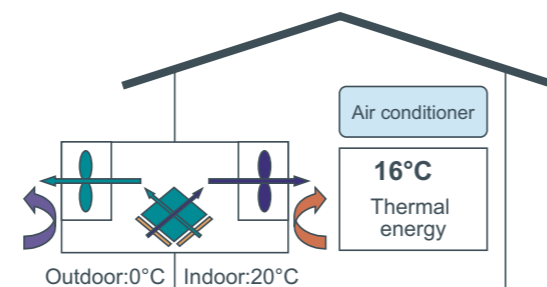

**How much recovery?**  
OA temp. : 0°C → SA temp. : 16°C (Indoor 20°C)

## Extra Low Mode

- **Additional energy conservation** by using a four-level air volume system that allows more precise control.

In addition to the conventional Extra High, High, and Low modes, an Extra Low mode is added to provide a more dynamic range of air volume settings and versatility in a variety of installation environments, yielding much better energy conservation. Using a simplified timer function, it switches to Extra Low operation when the operation stop button is activated and it is accordingly possible to implement 24-hour energy conservation ventilation.

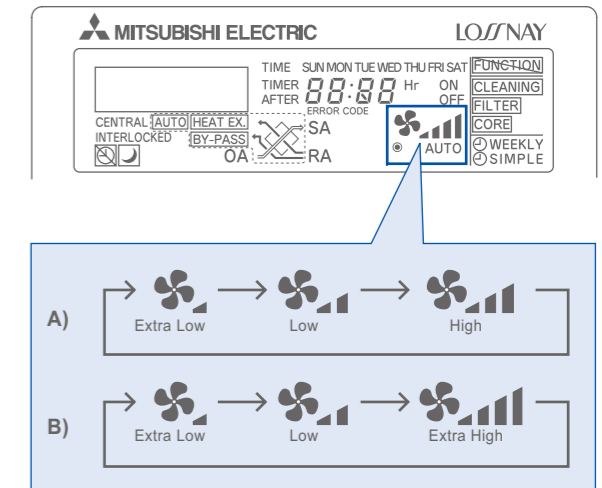

- \* The Extra High and High ventilation modes are selectable by the initial setting.
- \* Extra-Low not equipped LGH-150RXs and 200RXs.
- \* The ventilation mode is actually selected in three levels, and the remote controller also displays these three levels.

## Energy Saving by WEEKLY timer

Air volume level can be set hourly (max 8 times) and weekly. You can pre-set air volume according to the predictable requirement so that LOSSNAY can automatically operate at only necessary air-speed at the specified time period, which saves power consumption while maintaining the indoor air quality. Besides, once the weekly timer has been set, no switching on-off is required.

#### Example A (Hourly)

current RX<sub>4</sub> series with PZ-41SLB controller



new RX<sub>5</sub> series with PZ-60DR-E



Total power consumption in one day : LGH-100RX<sub>4</sub>-E : 6,600W (14 hours)  
LGH-100RX<sub>5</sub>-E : 5,390W (14 hours) → **1,210W (18%) less**

#### Example B (Weekly)



## New function: "By-pass" Ventilation External Control Setting

In addition to the automatic damper open/close function, open/close control via external devices is now possible, delivering a "By-pass" ventilation system that is suitable to the installed environment.

Establish the wire connection by inserting the optional remote display adaptor (PAC-SA88HA-E) in the connector CN16 (Ventilation mode selector).

With SW1 is "ON", the ventilation mode of LOSSNAY is changed to the By-pass ventilation regardless of the setting on the remote controller.

### •Automatic ventilation setting

The automatic damper mode automatically provides the correct ventilation for the conditions in the room. The following shows the effect "By-pass" ventilation will have under various conditions.

#### 1. Reduces cooling load

If the air outside is cooler than the air inside the building during the cooling season (such as early morning or at night), "By-pass" ventilation will draw in the cooler outside air and reduce the cooling load on the system.

#### Control devices (example)

- Temperature sensor
- Humidity sensor
- Timers

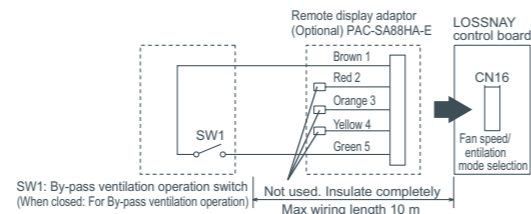
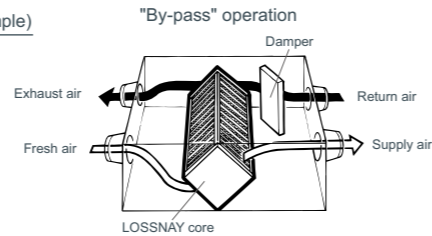

#### 2. Night purge

"By-pass" ventilation can be used to release hot air from inside the building that has accumulated in buildings a business district during the hot summer season.

#### 3. Office equipment room cooling

During cold season, fresh air can be drawn in and used as is to cool rooms where the temperature has risen due to the use of office equipment.

- \* When the outdoor air temperature drops lower than 8°C it changes to the heat exchange ventilation. (Display of the remote controller does not change.)
- \* In the case of "By-pass" ventilation, the supply air temperature slightly rises more than the outside air temperature because of the heat effect around the ducts or the unit motors.

## New Remote Controller PZ-60DR-E

A new remote controller for the RX5 series is now available. In addition to boosting the energy conservation performance of the main unit, the remote controller features a variety of new functions which also pursue additional energy conservation.

The appearance of the remote controller conforms to Mitsubishi air conditioner interface design standards.

Functions that were set using Dip-Switch on the LOSSNAY main unit can now be configured as needed using the new remote controller.

This eliminates the need to crawl under the eaves to change operation settings.

Also, a newly adopted dot matrix display provides much more information, making it easy to check maintenance indications, operation status display, and explanations required when configuring settings.

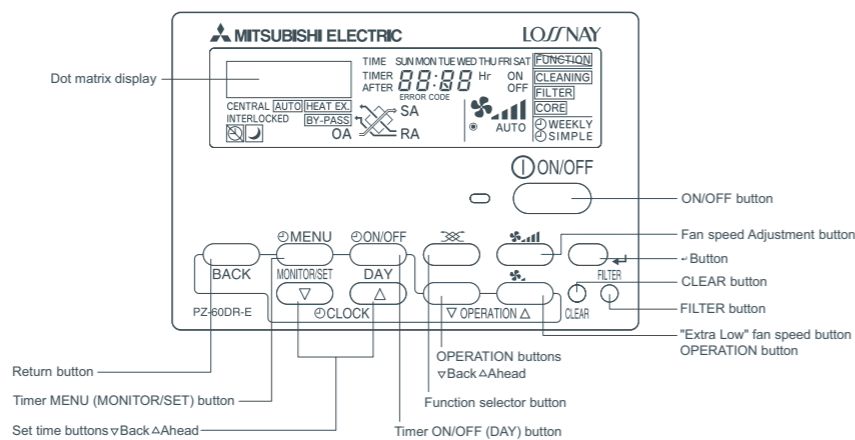

LGH-15~100RX5-E

## Model line up

### ■ Specification

#### LGH-15RX5-E

Model		LGH-15RX5-E								
Frequency / Power source		50Hz / Single phase 220-240V								
Ventilation mode		LOSSNAY ventilation				By-pass ventilation				
Fan speed		Extra High	High	Low	Extra Low	Extra High	High	Low	Extra Low	
Current (A)		0.44-0.46	0.37-0.38	0.25-0.25	0.14-0.15	0.45-0.46	0.37-0.38	0.25-0.26	0.14-0.15	
Power consumption (W)		96-110	80-90	53-59	30-35	97-110	81-91	54-61	30-35	
Air volume		(m <sup>3</sup> /h)	150	150	110	70	150	150	110	70
		(L/s)	42	42	31	19	42	42	31	19
External static pressure		(mmH <sub>2</sub> O)	10.2-10.7	6.6-7.1	3.6-4.1	1.4	10.2-10.7	6.6-7.1	3.6-4.1	1.4
		(Pa)	100-105	65-70	35-40	14	100-105	65-70	35-40	14
Temperature exchange efficiency (%)		82.0				85.5				
Enthalpy exchange efficiency (%)		Heating		75.0		75.0		77.5		
		Cooling		73.0		73.0		76.5		
Noise (dB) (Measured at 1.5m under the center of panel in an anechoic chamber)		27.5-28	26.5-27	22-23.5	18	28.5-29	27-28	23-24	18-19	
Weight (kg)		20								
Starting current		Under 0.8 A Less								

\*The Air outlets noise (45° angle, 1.5 meters in front of the unit) is about 6 dB greater than the indicated value. (at High Fan speed)

#### LGH-25RX5-E

Model		LGH-25RX5-E								
Frequency / Power source		50Hz / Single phase 220-240V								
Ventilation mode		LOSSNAY ventilation				By-pass ventilation				
Fan speed		Extra High	High	Low	Extra Low	Extra High	High	Low	Extra Low	
Current (A)		0.52-0.55	0.47-0.48	0.26-0.27	0.17-0.18	0.53-0.55	0.47-0.48	0.26-0.27	0.17-0.18	
Power consumption (W)		113-129	102-114	56-62	36-42	115-131	103-115	56-63	36-42	
Air volume		(m <sup>3</sup> /h)	250	250	155	105	250	250	155	105
		(L/s)	69	69	43	29	69	69	43	29
External static pressure		(mmH <sub>2</sub> O)	8.2-8.7	5.1-6.1	2-2.5	0.9	8.2-8.7	5.1-6.1	2-2.5	0.9
		(Pa)	80-85	50-60	20-25	9	80-85	50-60	20-25	9
Temperature exchange efficiency (%)		79.0				83.5				
Enthalpy exchange efficiency (%)		Heating		69.5		69.5		74.0		
		Cooling		68.0		68.0		72.5		
Noise (dB) (Measured at 1.5m under the center of panel in an anechoic chamber)		26-27	25-26	20-21.5	18-19	26.5-27.5	25.5-26.5	20.5-22	18-19	
Weight (kg)		20								
Starting current		Under 0.9 A Less								

\*The Air outlets noise (45° angle, 1.5 meters in front of the unit) is about 10 dB greater than the indicated value. (at High Fan speed)

#### LGH-35RX5-E

Model		LGH-35RX5-E								
Frequency / Power source		50Hz / Single phase 220-240V								
Ventilation mode		LOSSNAY ventilation				By-pass ventilation				
Fan speed		Extra High	High	Low	Extra Low	Extra High	High	Low	Extra Low	
Current (A)		0.92-0.92	0.74-0.74	0.5-0.51	0.28-0.3	0.93-0.94	0.77-0.77	0.51-0.52	0.28-0.3	
Power consumption (W)		195-212	160-169	105-116	58-69	197-217	164-173	105-116	58-69	
Air volume		(m <sup>3</sup> /h)	350	350	210	115	350	350	210	115
		(L/s)	97	97	58	32	97	97	58	32
External static pressure		(mmH <sub>2</sub> O)	15.8-16.3	7.6-8.2	2.5-3.1	0.9	15.8-16.3	7.6-8.2	2.5-3.1	0.9
		(Pa)	155-160	75-80	25-30	9	155-160	75-80	25-30	9
Temperature exchange efficiency (%)		80.0				88.0				
Enthalpy exchange efficiency (%)		Heating		71.5		71.5		76.5		
		Cooling		71.0		71.0		75.5		
Noise (dB) (Measured at 1.5m under the center of panel in an anechoic chamber)		32-32	28.5-29.5	21.5-23	18	32.5-32.5	29.5-30.5	21.5-24	18	
Weight (kg)		29								
Starting current		Under 2.4 A Less								

\*The Air outlets noise (45° angle, 1.5 meters in front of the unit) is about 10 dB greater than the indicated value. (at High Fan speed)



LGH-15~100RX5-E



LGH-15~100RX5-E



LGH-150/200RX5-E

LGH-50RX5-E

Model		LGH-50RX5-E							
Frequency / Power source		50Hz / Single phase 220-240V							
Ventilation mode		LOSSNAY ventilation				By-pass ventilation			
Fan speed		Extra High	High	Low	Extra Low	Extra High	High	Low	Extra Low
Current (A)		1.2-1.25	1.0-1.0	0.85-0.85	0.4-0.4	1.25-1.25	1.0-1.0	0.85-0.85	0.4-0.4
Power consumption (W)		255-286	207-228	175-190	80-95	260-290	210-230	180-195	80-95
Air volume	(m <sup>3</sup> /h)	500	500	390	180	500	500	390	180
	(L/s)	139	139	108	50	139	139	108	50
External static pressure	(mmH <sub>2</sub> O)	15.3-15.8	6.6-9.2	4.1-6.1	1.0	15.3-15.8	6.6-9.2	4.1-6.1	1.0
	(Pa)	150-155	65-90	40-60	10	150-155	65-90	40-60	10
Temperature exchange efficiency (%)		78.0	78.0	81.0	86.0	—	—	—	—
Enthalpy exchange efficiency (%)	Heating	69.0	69.0	71.0	78.0	—	—	—	—
	Cooling	66.5	66.5	68.0	77.0	—	—	—	—
Noise (dB) (Measured at 1.5m under the center of panel in an anechoic chamber)		33-34	30.5-32	26.5-28	19	34-35	31-32.5	27-29	19
Weight (kg)		32							
Starting current		Under 3.0 A Less							

\*The Air outlets noise (45° angle, 1.5 meters in front of the unit) is about 16 dB greater than the indicated value. (at High Fan speed)

LGH-65RX5-E

Model		LGH-65RX5-E							
Frequency / Power source		50Hz / Single phase 220-240V							
Ventilation mode		LOSSNAY ventilation				By-pass ventilation			
Fan speed		Extra High	High	Low	Extra Low	Extra High	High	Low	Extra Low
Current (A)		1.7-1.8	1.5-1.5	1.2-1.2	0.6-0.6	1.7-1.8	1.5-1.5	1.2-1.2	0.6-0.6
Power consumption (W)		350-380	308-322	248-265	120-140	350-385	310-335	250-265	120-140
Air volume	(m <sup>3</sup> /h)	650	650	520	265	650	650	520	265
	(L/s)	181	181	144	74	181	181	144	74
External static pressure	(mmH <sub>2</sub> O)	11.2-12.2	6.1-8.2	4.1-5.1	0.8	11.2-12.2	6.1-8.2	4.1-5.1	0.8
	(Pa)	110-120	60-80	40-50	8	110-120	60-80	40-50	8
Temperature exchange efficiency (%)		77.0	77.0	80.0	86.0	—	—	—	—
Enthalpy exchange efficiency (%)	Heating	68.5	68.5	70.5	78.0	—	—	—	—
	Cooling	66.0	66.0	68.5	77.0	—	—	—	—
Noise (dB) (Measured at 1.5m under the center of panel in an anechoic chamber)		34-34.5	32-33	28.5-31.5	22	34.5-35	32.5-33.5	28.5-30.5	22-22.5
Weight (kg)		40							
Starting current		Under 4.4 A Less							

\*The Air outlets noise (45° angle, 1.5 meters in front of the unit) is about 10 dB greater than the indicated value. (at High Fan speed)

LGH-80RX5-E

Model		LGH-80RX5-E							
Frequency / Power source		50Hz / Single phase 220-240V							
Ventilation mode		LOSSNAY ventilation				By-pass ventilation			
Fan speed		Extra High	High	Low	Extra Low	Extra High	High	Low	Extra Low
Current (A)		1.75-1.75	1.6-1.6	1.45-1.45	0.60-0.65	1.75-1.75	1.6-1.6	1.45-1.45	0.60-0.65
Power consumption (W)		380-415	345-370	315-340	125-145	380-415	345-370	315-340	120-145
Air volume	(m <sup>3</sup> /h)	800	800	700	355	800	800	700	355
	(L/s)	222	222	194	99	222	222	194	99
External static pressure	(mmH <sub>2</sub> O)	14.8-15.3	10.7-12.2	8.2-9.7	2	14.8-15.3	10.7-12.2	8.2-9.7	2
	(Pa)	145-150	105-120	80-95	20	145-150	105-120	80-95	20
Temperature exchange efficiency (%)		79.0	79.0	80.5	87.5	—	—	—	—
Enthalpy exchange efficiency (%)	Heating	71.0	71.0	72.5	79.5	—	—	—	—
	Cooling	70.0	70.0	71.5	79.5	—	—	—	—
Noise (dB) (Measured at 1.5m under the center of panel in an anechoic chamber)		33.5-34.5	32-33	30-31	22	34.5-35.5	33-34	31-32	22
Weight (kg)		53							
Starting current		Under 3.8 A Less							

\*The Air outlets noise (45° angle, 1.5 meters in front of the unit) is about 16 dB greater than the indicated value. (at High Fan speed)

LGH-100RX5-E

Model		LGH-100RX5-E							
Frequency / Power source		50Hz / Single phase 220-240V							
Ventilation mode		LOSSNAY ventilation				By-pass ventilation			
Fan speed		Extra High	High	Low	Extra Low	Extra High	High	Low	Extra Low
Current (A)		2.3-2.4	2.1-2.1	1.7-1.7	0.9-0.9	2.3-2.4	2.1-2.1	1.7-1.7	0.9-0.9
Power consumption (W)		500-535	445-475	350-380	175-200	510-550	460-485	365-395	175-200
Air volume	(m <sup>3</sup> /h)	1000	1000	755	415	1000	1000	755	415
	(L/s)	278	278	210	115	278	278	210	115
External static pressure	(mmH <sub>2</sub> O)	16.3-17.3	10.2-11.2	5.6-6.1	1.8	16.3-17.3	10.2-11.2	5.6-6.1	1.8
	(Pa)	160-170	100-110	55-60	18	160-170	100-110	55-60	18
Temperature exchange efficiency (%)		80.0	80.0	83.0	87.0	—	—	—	—
Enthalpy exchange efficiency (%)	Heating	72.5	72.5	74.0	80.0	—	—	—	—
	Cooling	71.0	71.0	73.0	79.0	—	—	—	—
Noise (dB) (Measured at 1.5m under the center of panel in an anechoic chamber)		36-37	34-35	31-32.5	21-22	37-38	35-36	32-33	21-22
Weight (kg)		59							
Starting current		Under 4.6 A Less							

\*The Air outlets noise (45° angle, 1.5 meters in front of the unit) is about 17 dB greater than the indicated value. (at High Fan speed)

LGH-150RX5-E

Model		LGH-150RX5-E					
Frequency / Power source		50Hz / Single phase 220-240V					
Ventilation mode		LOSSNAY ventilation			By-pass ventilation		
Fan speed		Extra High	High	Low	Extra High	High	Low
Current (A)		3.5-3.5	3.2-3.2	2.9-2.9	3.5-3.5	3.2-3.2	2.9-2.9
Power consumption (W)		760-830	690-740	630-680	765-835	695-745	635-685
Air volume	(m <sup>3</sup> /h)	1500	1500	1300	1500	1500	1300
	(L/s)	417	417	361	417	417	361
External static pressure	(mmH <sub>2</sub> O)	16.3-17.8	13.3-13.8	9.7-10.2	16.3-17.8	13.3-13.8	9.7-10.2
	(Pa)	160-175	130-135	95-100	160-175	130-135	95-100
Temperature exchange efficiency (%)		80.0	80.0	81.0	—	—	—
Enthalpy exchange efficiency (%)	Heating	72.0	72.0	72.5	—	—	—
	Cooling	70.5	70.5	71.5	—	—	—
Noise (dB) (Measured at 1.5m under the center of panel in an anechoic chamber)		38-39	36-37.5	33.5-35	39-40.5	37.5-39	35.5-37
Weight (kg)		105					
Starting current		Under 7.3 A Less					

\*The Air outlets noise (45° angle, 1.5 meters in front of the unit) is about 19 dB greater than the indicated value. (at High Fan speed)

LGH-200RX5-E

Model		LGH-200RX5-E					
Frequency / Power source		50Hz / Single phase 220-240V					
Ventilation mode		LOSSNAY ventilation			By-pass ventilation		
Fan speed		Extra High	High	Low	Extra High	High	Low
Current (A)		4.8-4.8	4.2-4.2	3.4-3.4	4.8-4.8	4.2-4.2	3.4-3.4
Power consumption (W)		1035-1100	910-980	715-785	1040-1110	915-980	720-785
Air volume	(m <sup>3</sup> /h)	2000	2000	1580	2000	2000	1580
	(L/s)	556	556	439	556	556	439
External static pressure	(mmH <sub>2</sub> O)	16.3-16.8	10.2-10.7	6.1-6.6	16.3-16.8	10.2-10.7	6.1-6.6
	(Pa)	160-165	100-105	60-65	160-165	100-105	60-65
Temperature exchange efficiency (%)		80.0	80.0	83.0	—	—	—
Enthalpy exchange efficiency (%)	Heating	72.5	72.5	73.5	—	—	—
	Cooling	71.0	71.0	72.0	—	—	—
Noise (dB) (Measured at 1.5m under the center of panel in an anechoic chamber)		39.5-40	37-38	32.5-34	40.5-41	38-39	33.5-35
Weight (kg)		118					
Starting current		Under 11.9A Less					

\*The Air outlets noise (45° angle, 1.5 meters in front of the unit) is about 20 dB greater than the indicated value. (at High Fan speed)



## Control

■ The New Remote Controller PZ-60DR-E enable simple control setting

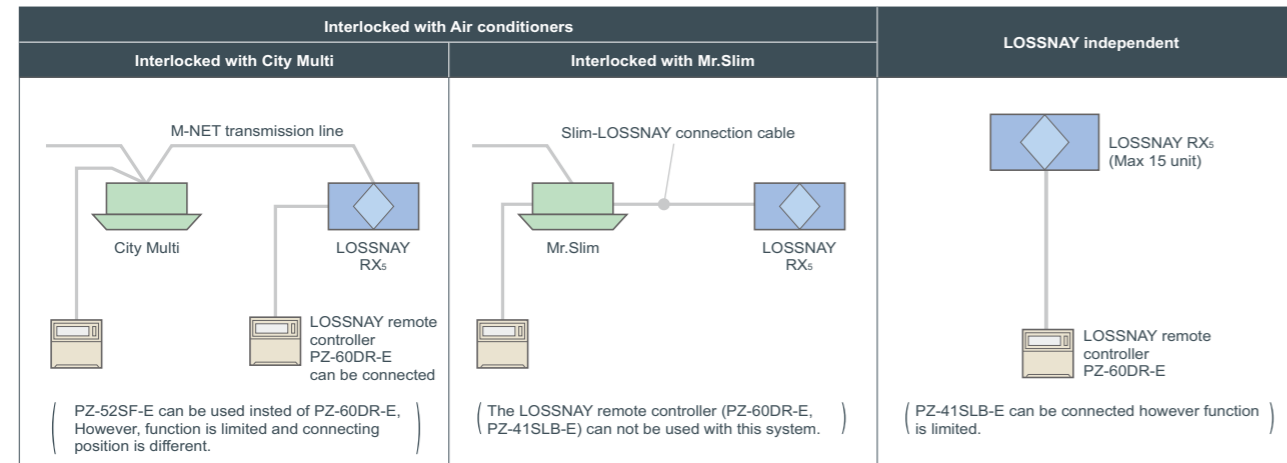

■ Centralized Controller System

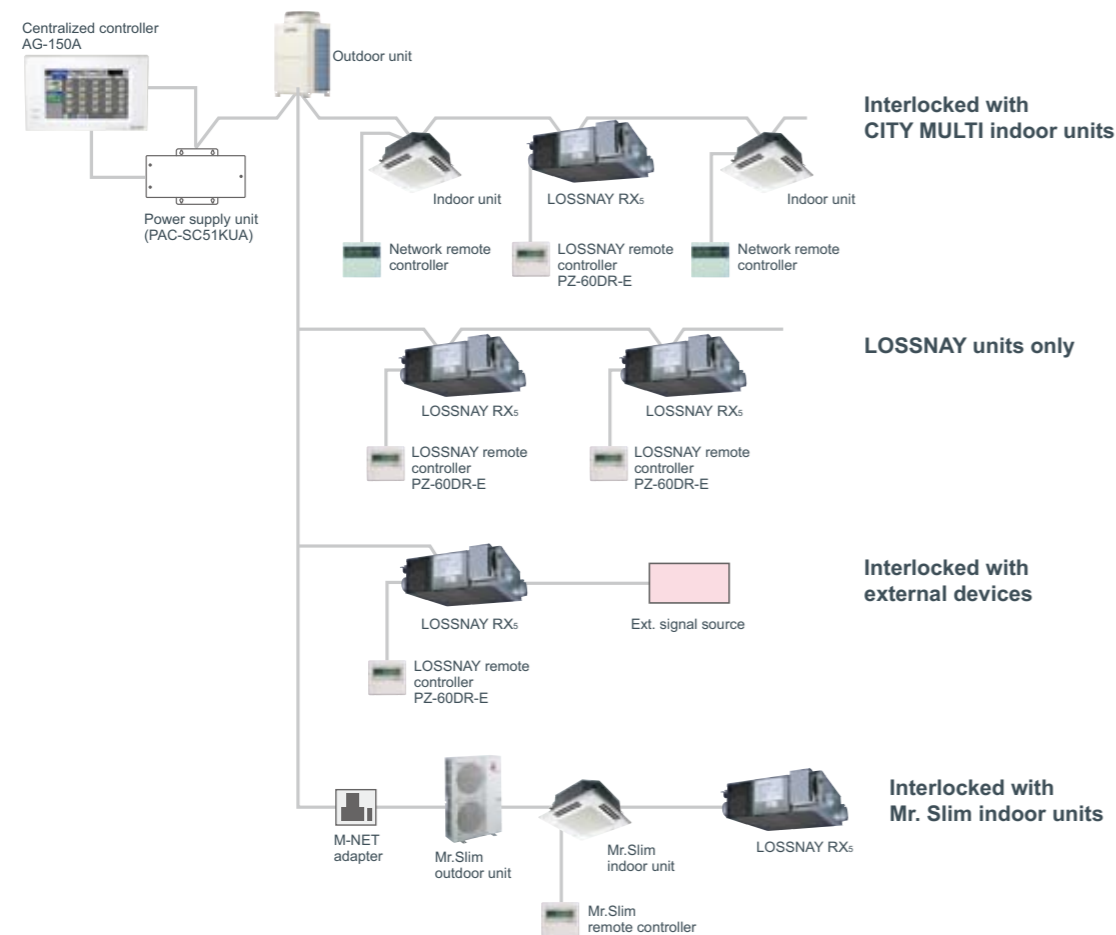

## Heat Recovery Ventilators for Residential Use

Time Spent in Comfort with a Breath of Fresh Air

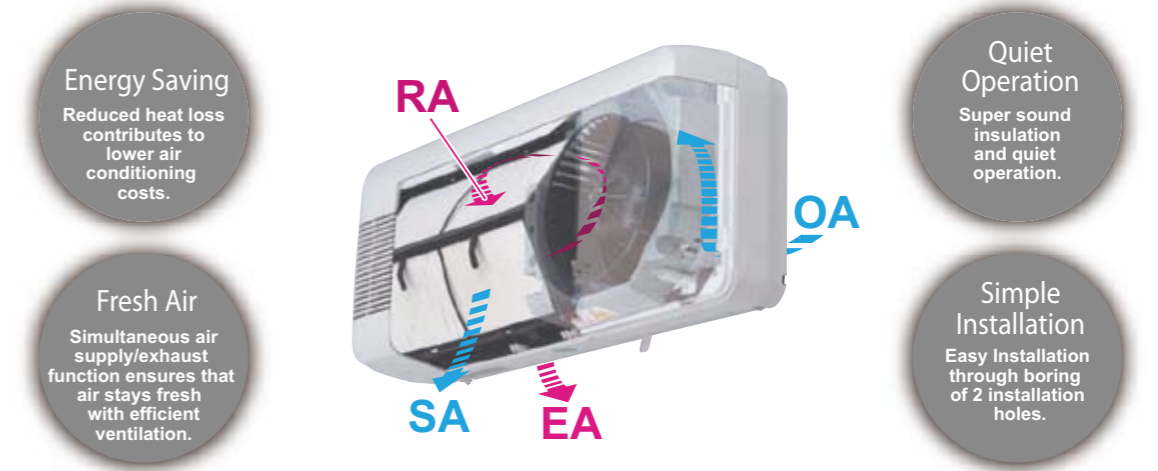

## Total-Heat-Exchange Concept

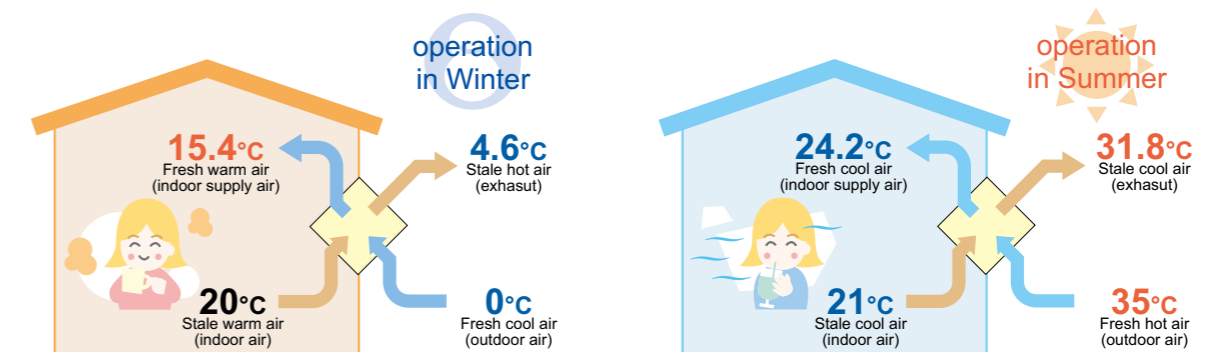

### Heat-exchange calculating equation

$$\text{Indoor supply-air temperature}(\text{°C}) = \left\{ \text{Indoor temperature}(\text{°C}) - \text{Outdoor temperature}(\text{°C}) \right\} \times \text{Temp exchange efficiency}(\%) + \text{Outdoor temperature}(\text{°C})$$

Calculation example : 15.4°C = (20°C - 0°C) x 77% + 0°C (Low notch)

### Heat-exchange calculating equation

$$\text{Indoor supply-air temperature}(\text{°C}) = \left\{ \text{Outdoor temperature}(\text{°C}) + \left\{ \text{Indoor temperature}(\text{°C}) - \text{Outdoor temperature}(\text{°C}) \right\} \times \text{Temp exchange efficiency}(\%) \right\}$$

Calculation example : 35°C = (35°C - 21°C) x 77% (Low notch)

## Specification

- Simple installation through boring of 2 installation holes.
- Low-noise(Less than 30dB at low notch).
- 1-motor 2-fan system. •Air-volume:low/high 2-notch.
- Air-supply/exhaust pipes and plastic weather cover are supplied as accessories.
- Equipped with an outdoor-air shutter. •Pull-string switch

Supply Voltage (V)	Power line frequency (Hz)	Notch	Air volume (m³/h)	Power Consumption (W)	Temp.exchange efficiency (%)	Noise (dB)	Weight (kg)
220-240	50	HI	105	26	70	39	6.5
		LO	65	23	77	29.5	
220	60	HI	90	26	73	37	
		LO	50	21	80	26	

## Optional parts

### Extension Pipe P-100P

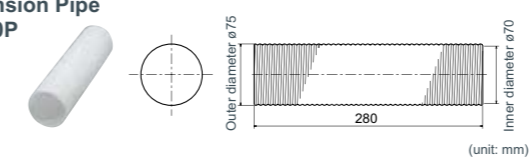

•Total length when connected to the pipe extension coupling is 300mm.

### Extension Pipe Coupling P-100PJ

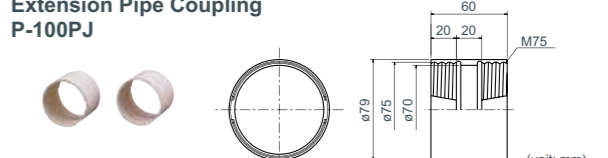

•Screw-in method

# OA Processing Units

## RDH3 Series

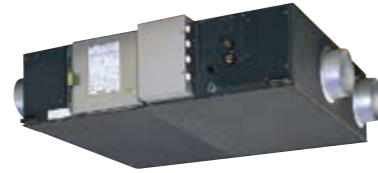

### Ideal Indoor-Air Quality — For Your Comfort and Health

The OA (outdoor-air) Processing Unit creates an optimum indoor-air environment at an unparalleled rate of cost efficiency providing substantial energy savings. Forced air ventilating and humidifying functions unique to this system keep indoor-air fresh and free of contaminants preventing “sick building syndrome” and the spread of airborne viruses such as the flu. Another novel feature of the OA Processing Unit is the “Lossnay core,” a heat-exchange unit that functions to transfer heat efficiently, cutting ventilation load by as much as 70%. This special combination of functionality and performance designed to ensure users ample comfort and year-round health which cannot be found anywhere else on the market.

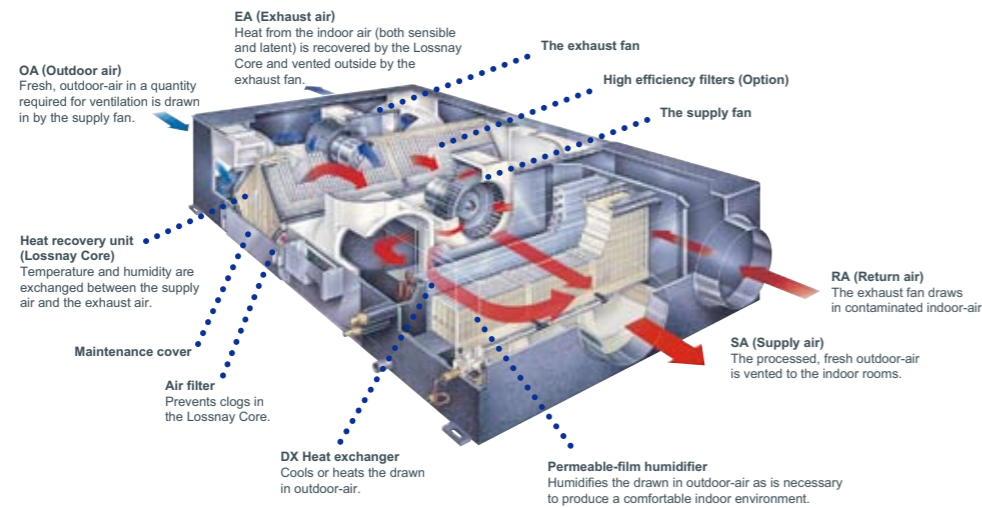

### New Permeable Film Humidifier (RDH3 model)

#### Comfortable Level of Humidity for Exceptionable Air Quality

The OA Processing Unit is equipped with a new permeable film humidifier developed and patented by Mitsubishi Electric. Steam transmission efficiency has been improved remarkably by lowering the resistance of the material. The use of a 3-layer film that allows only the transfer of steam prevents the production of white powder, so there is no need for the use of a water purifier.

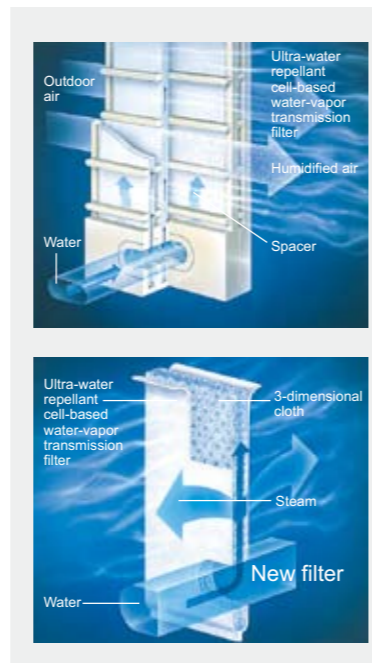

#### Highly Efficient Humidification

Improvements in the system of airflow patterns and water injection techniques have resulted in a substantial increase in humidifying volume.

## RD3 Series

### A Total Air Conditioning Package Manifesting Remarkable Power

#### Lossnay Ventilation and Air Conditioning

1. When the load is light ⇒ Main air conditioning
2. When the load is heavy ⇒ Supplemental air conditioning

The OA (outdoor-air) Processing Unit creates an optimum environment while providing substantial energy savings. The OA Processing Unit comprises forced air ventilation, heat recovery, heating and cooling, and air purification. This total air conditioning system keeps indoor air fresh and comfortable all year round, and keeps it free of contaminants preventing ailments such as sick building syndrome. Inside the OA Processing Unit is the Lossnay Core, a heat-exchange unit that transfers heat efficiently, cutting ventilation load by as much as 70%. A remarkable product found nowhere else, this special combination of functionality and performance contained within a single unit ensures users ample comfort, good health, and energy savings.

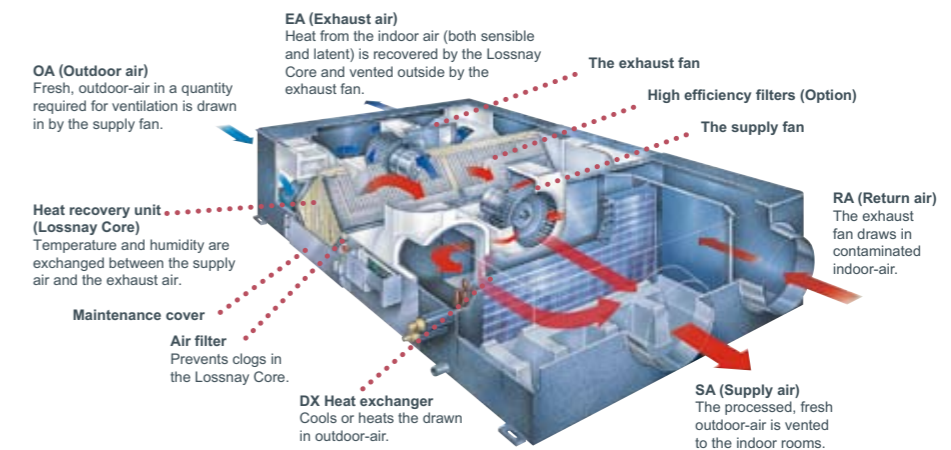

### The Air Conditioning Function

#### Two Units in One

Along with Lossnay ventilation, the OA Processing Unit is really two units in one, functioning as the main air conditioner when the load is light and adding supplemental air conditioning when the load is heavy. Also, with ventilation and air conditioning integrated, space is saved and installation expense kept to a minimum. What's more, the air temperature in any room can be perfectly adjusted to the desired

#### Temperature simulation (Example : GUF-50RD3)

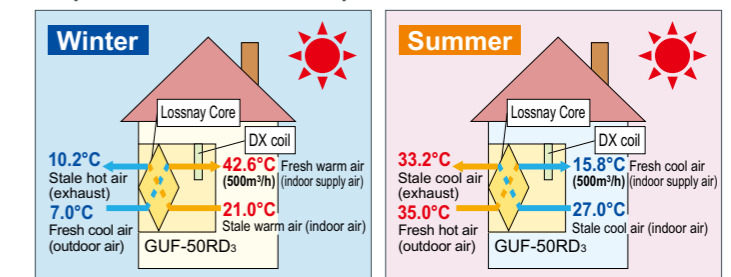

temperature of the occupants via the OA Processing Unit, which can be used as the indoor unit of the CITY MULTI air conditioning system. The heat recovery function maximizes efficiency and saves energy, benefiting the environment and helping companies cut costs. It also reduces the refrigerant load and lowers the amount of horsepower required by the outdoor unit.

## Specification

Model			GUF-50RDH <sub>3</sub> *3	GUF-100RDH <sub>3</sub> *3	GUF-50RD <sub>3</sub>	GUF-100RD <sub>3</sub>	
Power source			1-phase 220-240V 50Hz, 1-phase 220V 60Hz				
Cooling capacity	*1	kW	5.46 <1.83>	11.17 <3.85>	5.46 <1.83>	11.17 <3.85>	
	*1	kcal / h	4,700 <1,600>	9,600 <3,300>	4,700 <1,600>	9,600 <3,300>	
	*1	BTU / h	18,600 <6,200>	38,100 <13,100>	18,600 <6,200>	38,100 <13,100>	
Figure in < > is the recovery capacity by LOSSNAY core.							
Power input		kW	235-265	480-505	235-265	480-505	
Current input		A	1.15	2.20	1.15	2.20	
Heating capacity	*2	kW	6.18 <2.01>	12.50 <4.20>	6.18 <2.01>	12.50 <4.20>	
	*2	kcal / h	5,300 <1,700>	10,800 <3,600>	5,300 <1,700>	10,800 <3,600>	
	*2	BTU / h	21,100 <6,900>	42,700 <14,300>	21,100 <6,900>	42,700 <14,300>	
Figure in < > is the recovery capacity by LOSSNAY core.							
Power input		kW	235-265	480-505	235-265	480-505	
Current input		A	1.15	2.20	1.15	2.20	
Capacity equivalent to indoor unit			P32	P63	P32	P63	
Humidifying capacity		kg / h	2.7	5.4	-	-	
		lbs / h	6.0	12.0	-	-	
Humidifier			Permeable film humidifier			-	
External finish			Galvanized, with grey insulation sheet				
External dimension H x W x D		mm	317 x 1,016 x 1,288	398 x 1,231 x 1,580	317 x 1,016 x 1,288	398 x 1,231 x 1,580	
		in.	12-1/2 x 40 x 50-3/4	15-11/16 x 48-1/2 x 62-1/4	12-1/2 x 40 x 50-3/4	15-11/16 x 48-1/2 x 62-1/4	
Net weight		kg (lbs)	57 (126)	98 (217)	54 (120)	92 (203)	
Heat exchanger	LOSSNAY core		Partition, Cross-flow structure, Special preserved paper-plate.				
	Refrigerant coil		Cross fin (Aluminum fin and copper tube)				
FAN	Type x Quantity		SA: Centrifugal fan (Sirocco fan) x 1 EA: Centrifugal fan (Sirocco fan) x 1				
	External static press.	Pa	125	135	140	140	
		mmH <sub>2</sub> O	12.7	13.8	14.3	14.3	
	Motor type		Totally enclosed capacitor permanent split-phase induction motor, 4 poles, 2units				
	Motor output		kW	-	-	-	-
	Driving mechanism		Direct-driven by motor				
	Airflow rate (High value)	m <sup>3</sup> / h		500	1,000	500	1,000
		L / s		139	139	139	139
cfm		294	589	294	589		
Sound pressure level (Low-High) (measured in anechoic room)		dB <A>	33.5-34.5	38-39	33.5-34.5	38-39	
Insulation material			Polyester sheet				
Air filter	Supplying air		Non-woven fabrics filter (Gravitational method 82%) & Optional part: High efficiency filter (Colorimetric method 65%)				
	Exhausting air		Non-woven fabrics filter (Gravitational method 82%)				
Protection device			Fuse				
Refrigerant control device			LEV				
Diameter of refrigerant pipe	Liquid	mm (in.)	ø6.35 (ø1/4) Flare	ø9.52 (ø3/8) Flare	ø6.35 (ø1/4) Flare	ø9.52 (ø3/8) Flare	
	Gas	mm (in.)	ø12.7 (ø1/2) Flare	ø15.88 (ø5/8) Flare	ø12.7 (ø1/2) Flare	ø15.88 (ø5/8) Flare	
Diameter of drain pipe		mm (in.)	VP25				

### Notes:

- \*1 Cooling : Indoor 27°CDB/19°CWB, Outdoor 35°CDB/24°CWB
- \*2 Heating : Indoor 20°CDB/13.8°CWB, Outdoor 7°CDB/16°CWB
- \*3 Available for limited countries. Please contact your local distributor for further information.



## O outdoor unit

- **Heat Pump Series (S)**
- **Heat Pump Series (Y)**
- **Heat Pump Series - High COP (Y)**
- **Heat Pump Series - ZUBADAN (Y)**
- **Water cooled Heat Pump Series (WY)**
- **Heat Recovery Series (R2)**
- **Heat Recovery Series - High COP (R2)**
- **Water Cooled Heat Recovery Series (WR2)**



# S (Heat Pump) series Y (Heat Pump) series Cooling or Heating

S series — PUMY-P VHMB(-BS)  
PUMY-P YHMB(-BS)    Y series — PUHY-P YJM-A(-BS)  
PUHY-P YSJM-A(-BS)    PUHY-EP YJM-A(-BS)  
PUHY-EP YSJM-A(1)(-BS)

## The two-pipe zoned system designed for Heat Pump Operation

The CITY MULTI S series (for small applications) and Y series (for large applications) make use of a two-pipe refrigerant system, which allows for system changeover from cooling to heating, ensuring that a constant indoor climate is maintained in all zones. The compact outdoor unit utilizes R410A refrigerant and an INVERTER-driven compressor to use energy effectively.

With a wide line-up of indoor units in connection with a flexible piping system, the CITY MULTI series can be configured for all applications. Up to 12 (S series) or 50 (Y series) indoor units can be connected with up to 130% connected capacity to maximize engineer's design options. This feature allows easy air conditioning in each area with convenient individual controllers.

### Small Offices (S series)

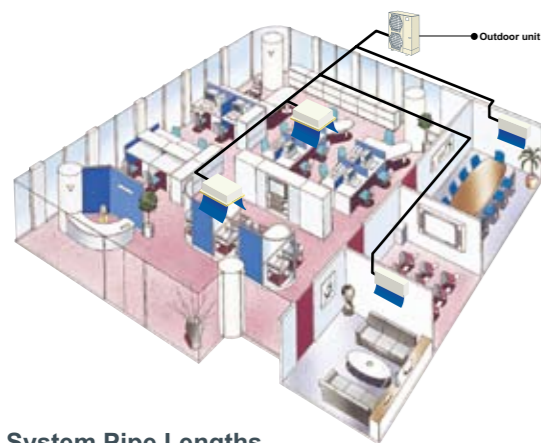

### Large Offices (Y series)

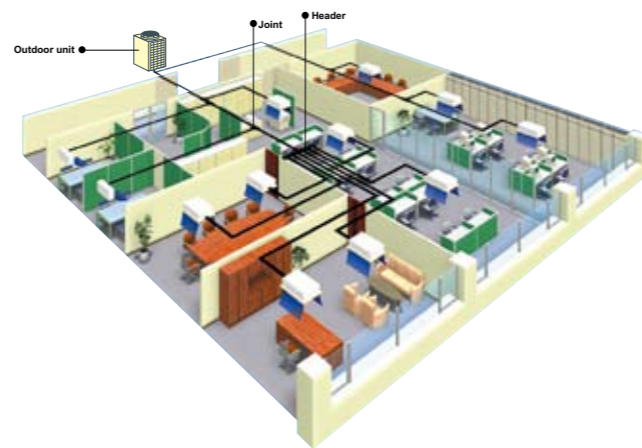

### System Pipe Lengths

[4-6HP (S series)]

Refrigerant Piping Lengths	Maximum meters [Feet]
Total length.....	120 [393]
Maximum allowable length.....	80 [262]
Farthest indoor from first branch.....	30 [98]

Vertical differentials between units	Maximum meters [Feet]
Indoor/outdoor (outdoor higher).....	50 [164]
Indoor/outdoor (outdoor lower).....	20 [65]
Indoor/indoor.....	12 [39]

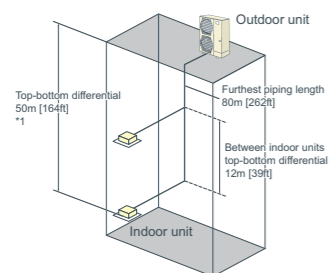

\*1 When the outdoor unit is installed below the indoor unit, top-bottom differential is 20m [65ft].

[8-50HP (Y series)]  
[8-36HP (High COP Y series)]

Refrigerant Piping Lengths	Maximum meters [Feet]
Total length.....	1,000 [3,280]
Maximum allowable length.....	165 (190equivalent) [541(623)]
Farthest indoor from first branch.....	40 [131]

Vertical differentials between units	Maximum meters [Feet]
Indoor/outdoor (outdoor higher).....	50 [164]*1
Indoor/outdoor (outdoor lower).....	40 [131]*1
Indoor/indoor.....	15 [49]

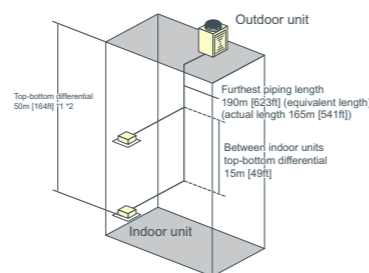

\*1 When the outdoor unit is installed below the indoor unit, top-bottom differential is 40m [131 ft].  
\*2 Depending on the model and installation conditions, top-bottom differential 90m [295ft] (o/u above) and 60m [196ft] (o/u below) is available. For more detailed information, please contact your nearest sales office or distributor.

# R2 (Heat Recovery) series Simultaneous Cooling and Heating

R2 series — PURY-P YJM-A(-BS)  
PURY-P YSJM-A(1)(-BS)    PURY-EP YJM-A(-BS)  
PURY-EP YSJM-A(1)(-BS)

## The world's first two-pipe system that Simultaneously Cools and Heats

CITY MULTI R2 series offers the ultimate in freedom and flexibility. Cool one zone while heating another. Our exclusive BC controller makes two-pipe simultaneous cooling and heating possible. The BC controller is the technological heart of the CITY MULTI R2 series. It houses a liquid and gas separator, allowing the outdoor unit to deliver a mixture of hot gas for heating and liquid for cooling, all through the same pipe.

This innovation results in virtually no energy wasted by being expelled outdoors. Depending on capacity, up to 50 indoor units can be connected with up to 150% connected capacity

### Installation image (R2 series)

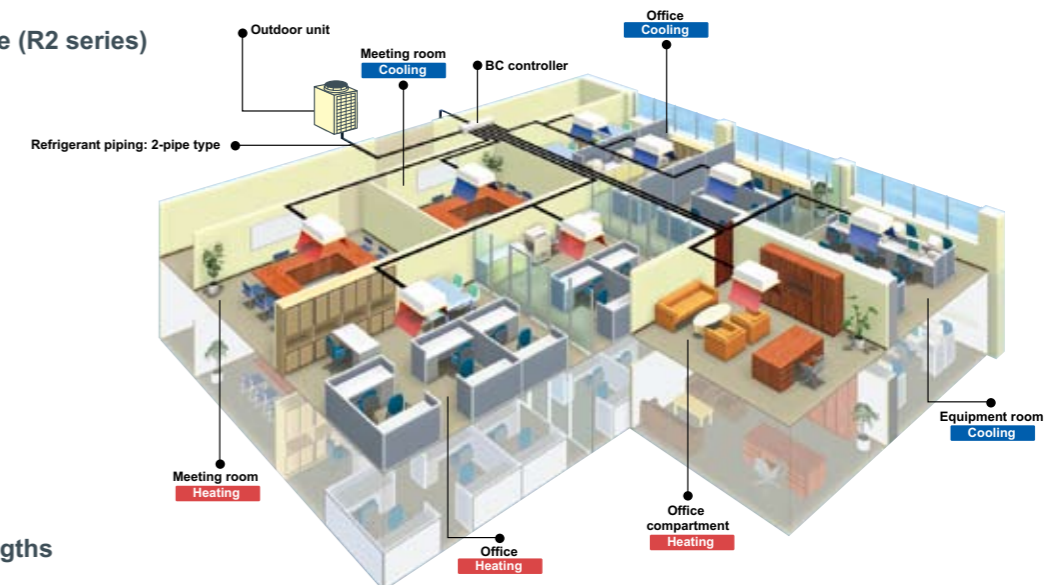

### System Pipe Lengths

[8-36HP (R2 series)]  
[8-26HP (High COP R2 series)]

Refrigerant Piping Lengths	Maximum meters [Feet]
Total length.....	550-800 [1,804-2,624] (P600,P650 models only; Refer to the Data book for other models.)
Maximum allowable length.....	165 (190equivalent) [541(623)]

Maximum length between outdoor and single/main BC controller..... 110 [360]  
\*Maximum total length is dependent upon the distance between the outdoor unit and the single/main BC Controller.  
Maximum length between single/main BC controller and indoor..... 40-60 [131-196]

Vertical differentials between units	Maximum meters [Feet]
Indoor/outdoor (outdoor higher).....	50 [164]*2
Indoor/outdoor (outdoor lower).....	40 [131]*2
Indoor/BC controller (single/main).....	15 [49]

\*Maximum length between single/main BC controller and indoor is dependent upon the vertical differential between the single/main BC controller and the indoor unit.  
Indoor/indoor..... 15 [49]  
Main BC Controller/Sub BC Controller... 15 [49]

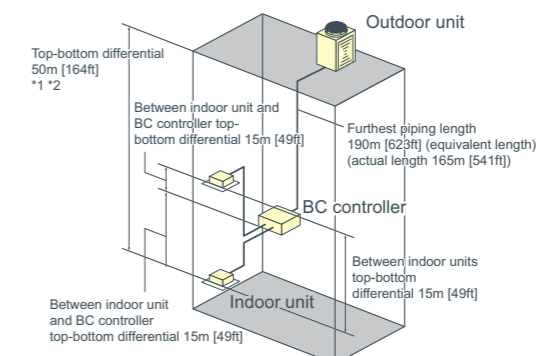

\*1 When the outdoor unit is installed below the indoor unit, top-bottom differential is 40m [131ft].  
\*2 Depending on the model and installation conditions, top-bottom differential 90m [295ft] (o/u above) and 60m [196ft] (o/u below) is available. For more detailed information, please contact your nearest sales office or distributor.

# Common Features in Y (Heat Pump) series & R2 (Heat Recovery) series

## New Lineup Y/R2 series(YJM)



In addition to outdoor unit "S" and "L" module, a new "XL" module is introduced. The three modular form can be combined to create systems up to 50HP in Y series and up to 36HP in R2 series.

### <Y Series-Standard>

HP	8	10	12	14	16	18	20	22	24	26	28	30	32	34	36	38	40	42	44	46	48	50
Capacity	Cooling 22.4	28	33.5	40	45	50	56	63	69	73	80	85	90	96	101	108	113	118	124	130	136	140
	Heating 25	31.5	37.5	45	50	56	63	69	76.5	81.5	88	95	100	108	113	119.5	127	132	140	145	150	156.5
Module (Pattern 1)	S module	●	●	●			●+●	●+●	●	●	●+●	●+●	●	●		●+●	●+●	●	●	●+●	●+●	●
	L module			●	●				●	●	●+●	●+●	●	●		●	●	●+●	●+●	●+●	●+●	●
	XL module					●					●	●	●	●	●+●	●+●	●	●	●+●	●+●	●+●	●+●
Module (Pattern 2)	S module					●+●	●+●	●+●	●													
	L module								●		●+●											
	XL module											●										

### <R2 Series-Standard>

HP	8	10	12	14	16	18	20	22	24	26	28	30	32	34	36
Capacity	Cooling 22.4	28	33.5	40	45	50	56	63	69	73	80	85	90	96	101
	Heating 25	31.5	37.5	45	50	56	63	69	76.5	81.5	88	95	100	108	113
Module (Pattern 1)	S module	●	●	●	●	●	●+●	●+●	●+●	●	●	●+●	●+●	●	●
	L module			●	●				●	●	●+●	●+●	●	●	
	XL module					●					●	●	●	●	●+●
Module (Pattern 2)	S module				●+●	●+●	●+●	●							
	L module							●		●+●			●		
	XL module								●			●			

## Improved performance

Improved heating capacity at low ambient temperature ensures 70% capacity at -15°C [5°F].

Cooling operation range is extended up to 46°C [115°F] from 43°C [109°F] with conventional model.

## Compact Design Industry leading weight saving

The manageability of the outdoor unit has been improved due to a drastic reduction in its weight, leading to easy transportation, installation, and reduction in withstand load.



## Effective Use of Space

The new models have a smaller foot print and service space requirement than previous models.

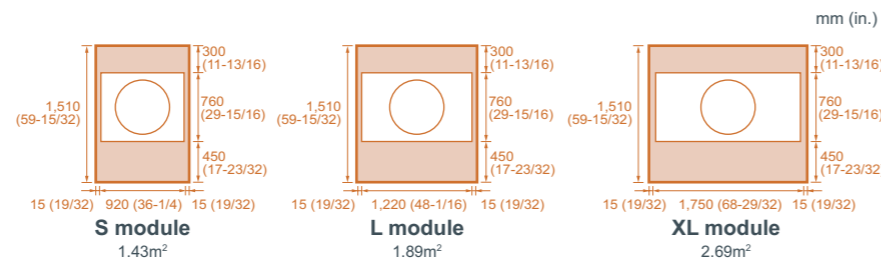

### P450 model (Y,R2 series)

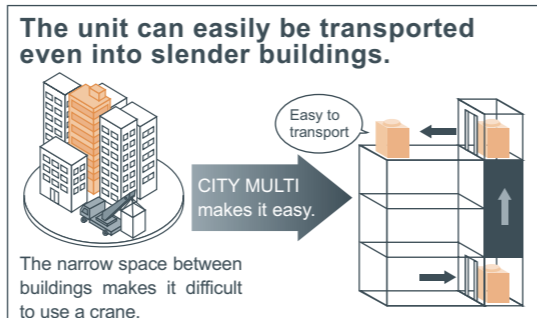
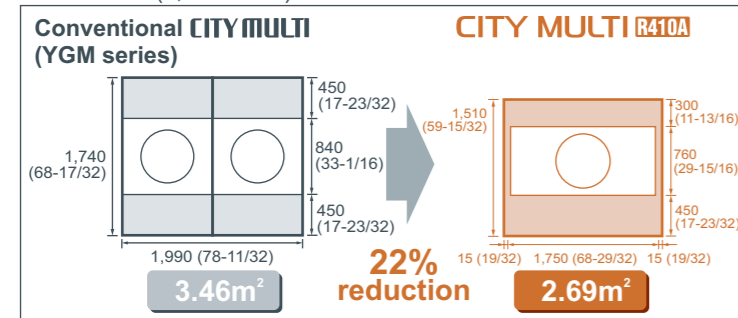

## Low Noise Levels New Fan Design

CITY MULTI VRF systems led the introduction of larger single fan motors some ten years ago, achieving substantially lower noise levels over multiple designs.

Continuing the development in the areas of blade shape and weight, Mitsubishi Electric have managed to achieve even higher performance and lower noise levels. To reduce noise levels further and comply with inner city residential noise regulations, all outdoor units include low noise mode. This function works by lowering the fan speed and compressor frequency proportionally with reduction in demand.

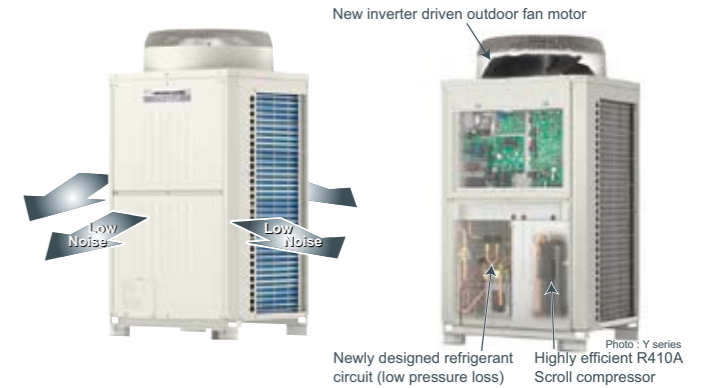

The compressor compartment is sealed by metal panels to attain low noise levels in all directions.

## R410A Pipe Sizing

As R410A has a higher specific heat capacity than R22, the pipework is smaller. This means the pipe itself is cheaper, easier to install and less riser space is required within the building.

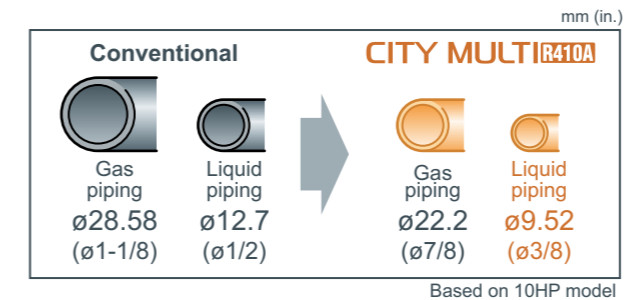

## Blue Fin Treatment

The anti-corrosion Blue Fin treatment of the heat exchanger is especially effective in urban environments where the traffic pollutions can damage the aluminum fins reducing the capacity and life expectancy of the unit. All CITY MULTI R410A outdoor units have been treated with Blue Fin.

\*Standard: Anti-corrosion Blue Fin treatment & copper tube. BS type (optional): salt-resistant cross fin & copper tube.

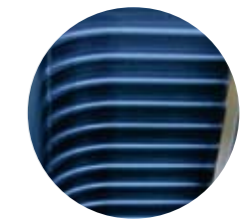

## Easy Maintenance

Even when one of the indoor units in the system is under maintenance, the other indoor unit can still operate.

\* Not applicable to all situations. \* Be sure to turn off the power to the indoor unit when repairing or servicing the unit.

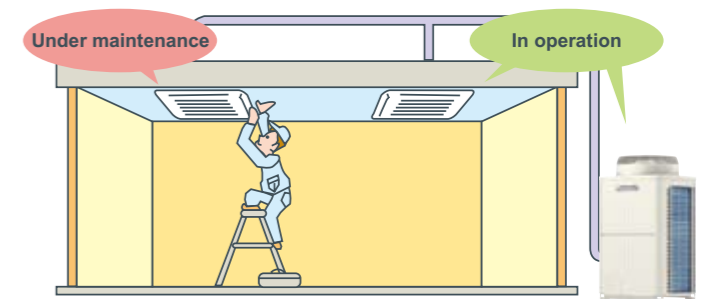

## System Check

Ensuring simple and easy maintenance, system tests are available to check wiring, sensors and the refrigerant amount.

## 60Pa High Static Pressure as standard

Both Y and R2 series correspond to high static pressure of 60Pa, ideal and flexible for any type of application.

# Cooling or Heating

ZUBADAN series — [PUHY-HP YHM-A(-BS)  
PUHY-HP YSHM-A(-BS)]

## Bringing a year round comfort solutions to extreme climates

CITY MULTI ZUBADAN series combines the ultimate in application flexibility and powerful cooling and heating capabilities to deliver precise comfort even in the coldest days of the year down to -25°C. The technology behind this is a Flash Injection circuit which provides optimum amount of refrigerant to the system via a compressor through a specially designed injection port to ensure a particularly stable operation. With this, ZUBADAN can provide a full heating performance even at -15°C and continuous heating for up to 250 minutes in one continuous cycle, ensuring a phenomenal heating performance at low temperatures.

### Installation image

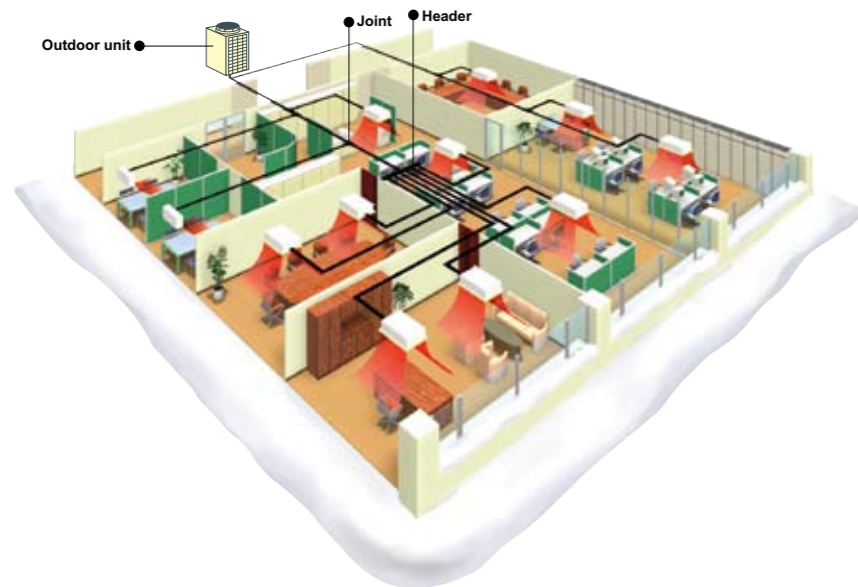

### System Pipe Lengths

[8-10HP]	
Refrigerant Piping Lengths	Maximum meters [Feet]
Total length.....	300 [984]
Maximum allowable length.....	150 (175equivalent) [492 (574)]
Farthest indoor from first branch.....	40 [131]
Vertical differentials between units	
Indoor/outdoor (outdoor higher).....	50 [164]
Indoor/outdoor (outdoor lower).....	40 [131]
Indoor/indoor.....	15 [49]

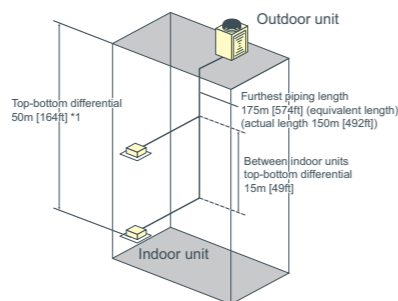

\*1 When the outdoor unit is installed below the indoor unit, top-bottom differential is 40m [131 ft].

## Stable Heating Performance even at -15°C

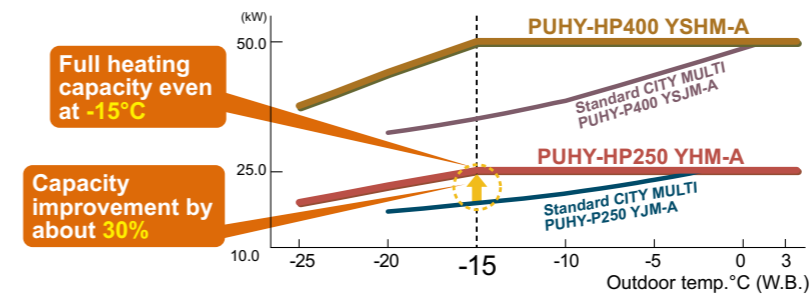

Using an industry first 'Flash-injection Circuit', the ZUBADAN System is able to provide FULL heating performance in ambient temperatures as low as -15°C.

## Expanded Heating Operation down to -25°C

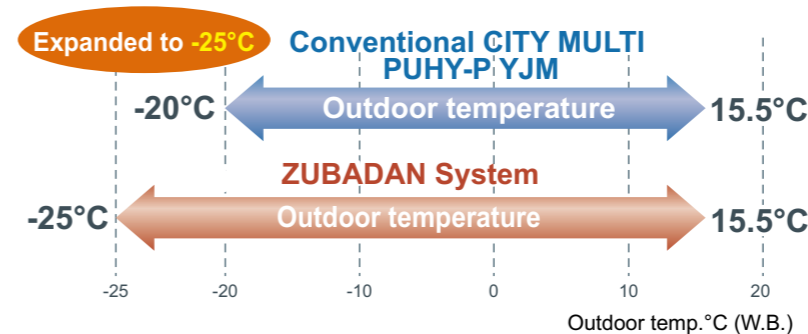

...furthermore, from a previous LOWEST operating ambient temperature of -20°C, the ZUBADAN System pushes the boundaries of technology to give heating in ambient temperatures as low as -25°C.

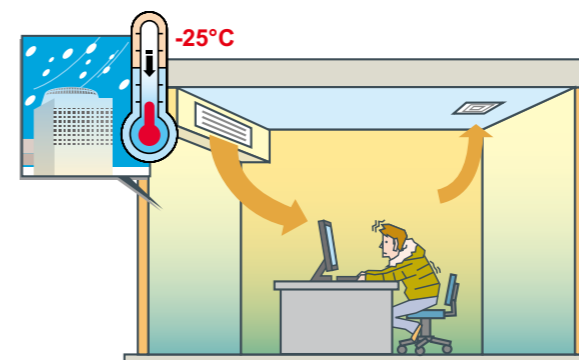

Previously, heating performance drops off when the temperature falls below -20°C!

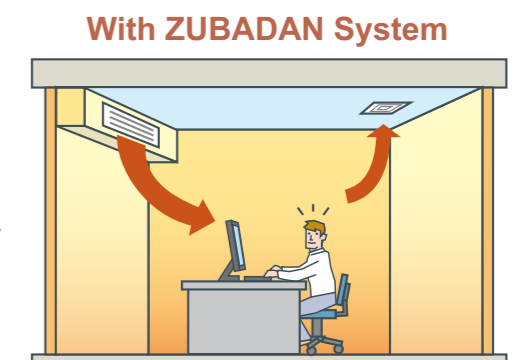

...however, even at such temperatures, the new ZUBADAN System has no trouble keeping the occupants nice and toasty!

## High Static Pressure Setting

High Static Pressure Setting up to 60Pa is available. With our new ZUBADAN model, high static pressure setting up to 60Pa is available by setting the dip switch (0Pa at factory setting) making it ideal and flexible for any type of application.

## Shorter Warm-up in about 20 Min.

With its new improved startup performance, the ZUBADAN system achieves full heating capacity even when outdoor temperature is as low as -15°C. Heating capacity, about 20 minutes after startup is improved by 40% compared to the conventional model; ensuring occupants an immediate comfortable air solution.

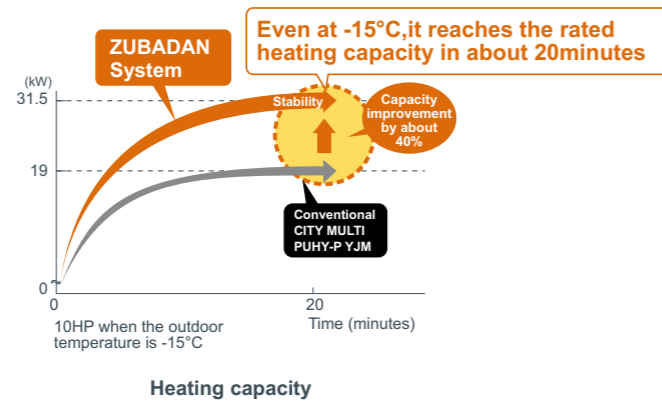

## Reliable and Long Product Life Cycle

### Backup Function (HP400 and HP500 models)

ZUBADAN system ensures an exceptionally high level of reliability by utilizing a new backup function, which can be easily operated in the case of a malfunction from an indoor unit remote controller.



### Rotation Function (HP400 and HP500 models)

Running outdoor units alternatively using its newly developed 'Rotation Function', the system is able to ensure an optimum product life cycle for both of its component units.



## Maximum Stable Operation

By utilizing our advanced Flash Injection Circuit, the system can not only provide continuous heating for up to 250 minutes in one continuous cycle, but also significantly lessens defrost time to give an exceptionally stable heating operation.

**Heating up to 250 min. straight** **Reduced Defrosting time**

## Startup Comfort

One of the key factors of the units newly designed Flash Injection Circuit is that the optimal amount of refrigerant can be provided to the system via the compressor through a specially designed injection port to ensure a particularly stable operation. In simple terms, the system allows a quick startup time and continuous heating; even in low ambient conditions.

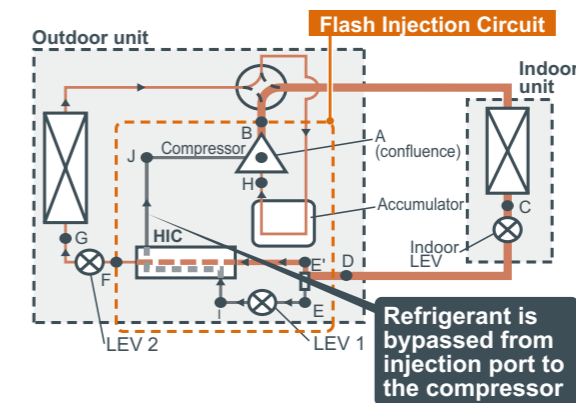

Note: Heat Interchange Circuit (HIC) Heating efficiency is improved by enhancing the recollection of heat at the outdoor unit with the low temperature refrigerant from the HIC.

## Constant Comfort

With its new highly effective defrost feature (which prevents automatic defrosting when it is not required), the ZUBADAN System can deliver conditioned heating operation up to 250 minutes in one continuous cycle!

### Heating capacity is maintained by the Flash-injection circuit.

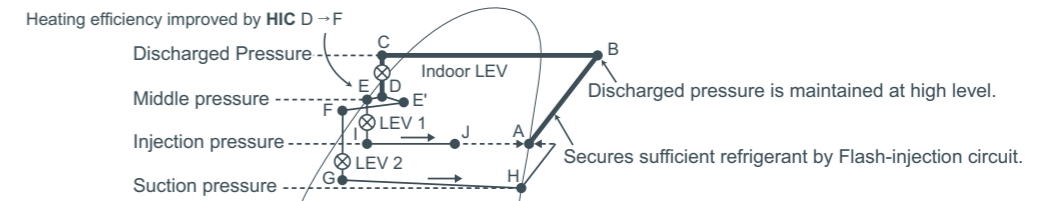

[Pressure Enthalpy diagram showing HIC]

# Water Cooled Series

## Cooling or Heating

WY series — PQHY-P YHM-A  
PQHY-P YSHM-A

WR2 series — PQRY-P YHM-A  
PQRY-P YSHM-A

### [WY(Heat Pump) series]

## Water energy source system allows switching between cooling and heating.

The WY-Series has all the benefits of the Y-Series using water source condensing units. Condensing units can be situated indoors allowing greater design flexibility and no limitation on building size. Depending on capacity, up to 17 to 50 indoor units can be connected to a single condensing unit with individualized and/or centralized control. The two-pipe system allows all CITY MULTI solutions to switch between cooling and heating while maintaining a constant indoor temperature.

#### Installation image (WY series)

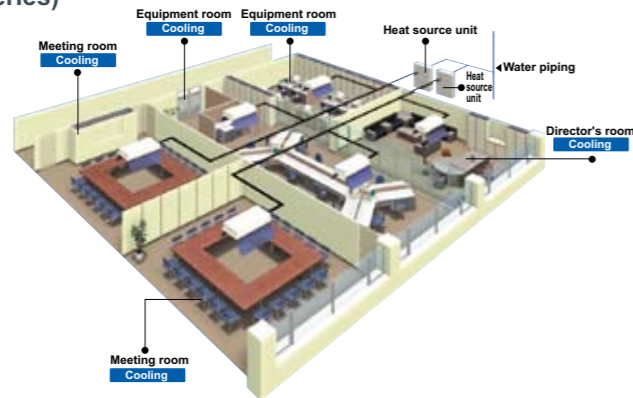

### [WR2(Heat Recovery) series]

## Advanced water heat source unit enjoying the benefits of R2 series

The CITY MULTI WR2 series provides all of the advantages of the R2 series with the added advantages of a water heat source system, making it suitable for wider range of applications in high rises, frigid climates, coastal areas, etc.

Not only does it produce heat recovery from the indoor units on the same 2-pipe refrigerant circuit, it also produces heat recovery via the water circuit between heat source units, making it a very economical system.

#### Installation image (WR2 series)

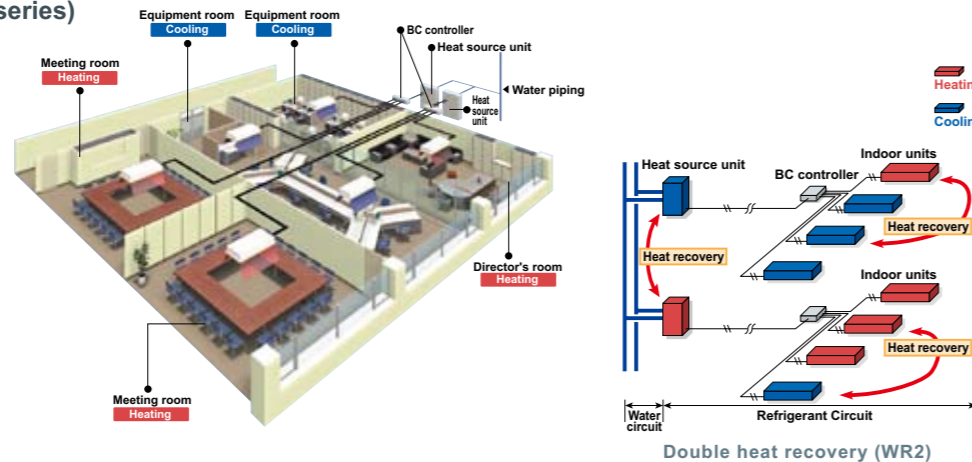

### System Pipe Lengths

#### [8-36HP (WY series)]

Refrigerant Piping Lengths	Maximum meters [Feet]
Total length (8-12HP)	300 [984]
Total length (16-36HP)	500 [1,640]
Maximum allowable length	165 (190equivalent) [541 (623)]
Farthest indoor from first branch	40 [131]
Vertical differentials between units	Maximum meters [Feet]
Indoor/heat source (heat source higher)	50 [164]
Indoor/heat source (heat source lower)	40 [131]
Indoor/indoor	15 [49]

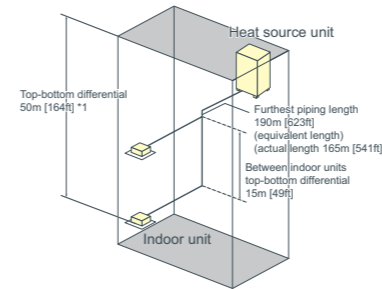

\*1 When the outdoor unit is installed below the indoor unit, top-bottom differential is 40m [131ft].

#### [8-24HP (WR2 series)]

Refrigerant Piping Lengths	Maximum meters [Feet]
Total length (8-12HP)	300-550 [984-1,804]
Total length (16-24HP)	500-750 [1,640-2,460]
Maximum allowable length	165 (190equivalent) [541 (623)]
Maximum length between heat source and single/main BC controller	110 [360]
*Maximum total length is dependent upon the distance between the outdoor unit and the single/main BC Controller.	
Maximum length between single/main BC controller and indoor	40-60 [131-196]
Vertical differentials between units	Maximum meters [Feet]
Indoor/heat source (heat source higher)	50 [164]
Indoor/heat source (heat source lower)	40 [131]
Indoor/BC controller (single/main)	15 [49]
Indoor/indoor	15 (10) [49 (32)]
Main BC Controller/Sub BC Controller	15 (10) [49 (32)]

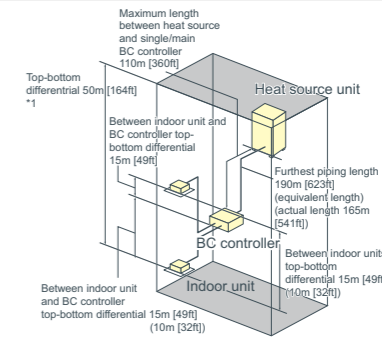

\*1 When the outdoor unit is installed below the indoor unit, top-bottom differential is 40m [131ft].

## COP comparison (energy efficiency)

The new water cooled outdoor unit offers a greater efficiency with a higher COP compared to our YGM conventional model.

#### COP comparison

		HP	HP														
			8	10	12	16	18	20	22	24	26	28	30	32	34	36	
PQHY	YGM	Cooling	4.68	4.71	-	3.96	-	3.72	-	-	-	-	-	-	-	-	-
		Heating	4.68	4.71	-	3.96	-	3.72	-	-	-	-	-	-	-	-	-
NEW	YHM	Cooling	5.71	5.13	4.55	5.45	5.08	4.89	4.68	4.45	5.22	5.13	4.94	4.69	4.52	4.34	
		Heating	6.06	5.43	4.60	5.78	5.37	5.22	4.70	4.46	5.52	5.33	5.19	4.82	4.65	4.40	
PQRY	YGM	Cooling	4.68	4.71	-	3.96	-	3.72	-	-	-	-	-	-	-	-	
		Heating	5.33	5.43	-	4.54	-	4.63	-	-	-	-	-	-	-	-	
NEW	YHM	Cooling	5.65	5.08	4.50	5.40	5.03	4.84	4.63	4.41	-	-	-	-	-	-	
		Heating	6.06	5.43	4.60	5.78	5.37	5.22	4.70	4.46	-	-	-	-	-	-	

## Compact design

Downsized by approximately 57%\*, the new models enable an effective use of space.

\*8/10/12HP

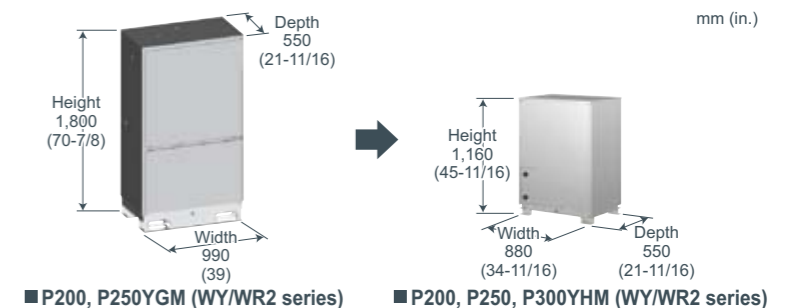

## Weight saving

The reduction in weight leads to easy transportation and installation.

#### Weight comparison

		HP	unit : kg													
			8	10	12	16	18	20	22	24	26	28	30	32	34	36
PQHY	YGM		272	275	-	452	-	456	-	-	-	-	-	-	-	-
	YHM	NEW	195	195	195	390	390	390	390	390	585	585	585	585	585	585
PQRY	YGM		263	266	-	440	-	444	-	-	-	-	-	-	-	-
	YHM	NEW	181	181	181	362	362	362	362	362	-	-	-	-	-	-

# Wide selection of outdoor units

## Heat Pump Series

**S Series (4HP-6HP)** Page98,99

PUMY-P VHMB(-BS)  
PUMY-P YHMB(-BS)



Model	4HP	5HP	6HP
Model Name	PUMY-P100VHMB(-BS) PUMY-P100YHMB(-BS)	PUMY-P125VHMB(-BS) PUMY-P125YHMB(-BS)	PUMY-P140VHMB(-BS) PUMY-P140YHMB(-BS)

**Y Series (8HP-12HP)** Page100

PUHY-P YJM-A(-BS)



Model	8HP	10HP	12HP
Model Name	PUHY-P200YJM-A(-BS)	PUHY-P250YJM-A(-BS)	PUHY-P300YJM-A(-BS)

**Y Series (44HP-48HP)** Page107

PUHY-P YSJM-A(-BS)



Model	44HP	46HP	48HP
Model Name	PUHY-P1100YSJM-A(-BS)	PUHY-P1150YSJM-A(-BS)	PUHY-P1200YSJM-A(-BS)

**Y Series (50HP)** Page108

PUHY-P YSJM-A(-BS)



Model	50HP
Model Name	PUHY-P1250YSJM-A(-BS)

**Y Series (14HP-18HP)** Page101

PUHY-P YJM-A(-BS)



Model	14HP	16HP	18HP
Model Name	PUHY-P350YJM-A(-BS)	PUHY-P400YJM-A(-BS)	PUHY-P450YJM-A(-BS)

**Y Series (20HP-24HP)** Page102

PUHY-P YSJM-A(-BS)  
PUHY-P YSJM-A1(-BS)



Model	20HP	20HP	22HP	24HP
Model Name	PUHY-P500YSJM-A(-BS)	PUHY-P500YSJM-A1(-BS)	PUHY-P650YSJM-A(-BS)	PUHY-P600YSJM-A1(-BS)

**Heat Pump Series - High COP**

**Y Series - High COP (8HP-12HP)** Page109

PUHY-EP YJM-A(-BS)



Model	8HP	10HP	12HP
Model Name	PUHY-EP200YJM-A(-BS)	PUHY-EP250YJM-A(-BS)	PUHY-EP300YJM-A(-BS)

**Y Series - High COP (16HP-20HP)** Page110

PUHY-EP YSJM-A(-BS)



Model	16HP	18HP	20HP
Model Name	PUHY-EP400YSJM-A(-BS)	PUHY-EP450YSJM-A(-BS)	PUHY-EP500YSJM-A(-BS)

**Y Series (24HP-28HP)** Page103

PUHY-P YSJM-A(-BS)  
PUHY-P YSJM-A1(-BS)



Model	24HP	26HP	28HP
Model Name	PUHY-P600YSJM-A(-BS)	PUHY-P650YSJM-A(-BS)	PUHY-P700YSJM-A1(-BS)

**Y Series (28HP-32HP)** Page104

PUHY-P YSJM-A(-BS)  
PUHY-P YSJM-A1(-BS)



Model	28HP	30HP	32HP
Model Name	PUHY-P700YSJM-A(-BS)	PUHY-P750YSJM-A(-BS)	PUHY-P800YSJM-A1(-BS)

**Y Series - High COP (20HP-24HP)** Page111

PUHY-EP YSJM-A(-BS)  
PUHY-EP YSJM-A1(-BS)



Model	20HP	22HP	24HP
Model Name	PUHY-EP500YSJM-A1(-BS)	PUHY-EP550YSJM-A(-BS)	PUHY-EP600YSJM-A(-BS)

**Y Series - High COP (26HP-28HP)** Page112

PUHY-EP YSJM-A(-BS)



Model	26HP	28HP
Model Name	PUHY-EP650YSJM-A(-BS)	PUHY-EP700YSJM-A(-BS)

**Y Series (32HP-36HP)** Page105

PUHY-P YSJM-A(-BS)



Model	32HP	34HP	36HP
Model Name	PUHY-P800YSJM-A(-BS)	PUHY-P850YSJM-A(-BS)	PUHY-P900YSJM-A(-BS)

**Y Series (38HP-42HP)** Page106

PUHY-P YSJM-A(-BS)



Model	38HP	40HP	42HP
Model Name	PUHY-P950YSJM-A(-BS)	PUHY-P1000YSJM-A(-BS)	PUHY-P1050YSJM-A(-BS)

**Y Series - High COP (28HP-30HP)** Page113

PUHY-EP YSJM-A(-BS)  
PUHY-EP YSJM-A1(-BS)



Model	28HP	30HP
Model Name	PUHY-EP700YSJM-A1(-BS)	PUHY-EP750YSJM-A(-BS)

**Y Series - High COP (30HP-32HP)** Page114

PUHY-EP YSJM-A(-BS)  
PUHY-EP YSJM-A1(-BS)



Model	30HP	32HP
Model Name	PUHY-EP750YSJM-A1(-BS)	PUHY-EP800YSJM-A(-BS)

\*The PUHY-P-YSJM-A(1) series requires a Twinning kit (optional). Refer to the data book for details.

\* The PUHY-P-YSJM-A(1) and PUHY-EP-YSJM-A(1) series requires a Twinning kit (optional). Refer to the data book for details.  
\* Unit photos are all standard models.

# Wide selection of outdoor units

**Y Series - High COP (32HP-34HP)** Page115

**PUHY-EP YSJM-A(-BS)**  
**PUHY-EP YSJM-A1(-BS)**



Model	32HP	34HP
Model Name	PUHY-EP800YSJM-A1(-BS)	PUHY-EP850YSJM-A(-BS)

**Y Series - High COP (36HP)** Page116

**PUHY-EP YSJM-A(-BS)**



Model	36HP
Model Name	PUHY-EP900YSJM-A(-BS)

## Heat Pump Series - ZUBADAN (Y)

**ZUBADAN Series (8HP-20HP)** Page117

**PUHY-HP YHM-A(-BS)**  
**PUHY-HP YSHM-A(-BS)**



Model	8HP	10HP	16HP	20HP
Model Name	PUHY-HP200YHM-A(-BS)	PUHY-HP250YHM-A(-BS)	PUHY-HP400YSHM-A(-BS)	PUHY-HP500YSHM-A(-BS)

## Water Cooled Heat Pump Series

**WY (Heat Pump) Series (8HP-24HP)** Page118~120

**PQHY-P YHM-A**  
**PQHY-P YSHM-A**



Model	8HP	10HP	12HP	16HP
Model Name	PQHY-P200YHM-A	PQHY-P250YHM-A	PQHY-P300YHM-A	PQHY-P400YSHM-A
Model	18HP	20HP	22HP	24HP
Model Name	PQHY-P450YSHM-A	PQHY-P500YSHM-A	PQHY-P550YSHM-A	PQHY-P600YSHM-A

**WY (Heat Pump) Series (26HP-36HP)** Page121~123

**PQHY-P YSHM-A**



Model	26HP	28HP	30HP	32HP
Model Name	PQHY-P650YSHM-A	PQHY-P700YSHM-A	PQHY-P750YSHM-A	PQHY-P800YSHM-A
Model	34HP	36HP		
Model Name	PQHY-P850YSHM-A	PQHY-P900YSHM-A		

\* The PUHY-EP-YSJM-A(1), PUHY-HP-YSHM-A and PQHY-P-YSHM-A series requires a Twinning kit (optional). Refer to the data book for details.  
\* Unit photos are all standard models.

# Wide selection of outdoor units

## Heat Recovery Series

**R2 Series (8HP-12HP)** Page124

**PURY-P YJM-A(-BS)**



Model	8HP	10HP	12HP
Model Name	PURY-P200YJM-A(-BS)	PURY-P250YJM-A(-BS)	PURY-P300YJM-A(-BS)

**R2 Series (14HP-18HP)** Page125

**PURY-P YJM-A(-BS)**



Model	14HP	16HP	18HP
Model Name	PURY-P350YJM-A(-BS)	PURY-P400YJM-A(-BS)	PURY-P450YJM-A(-BS)

**R2 Series (16HP-20HP)** Page126

**PURY-P YSJM-A(-BS)**  
**PURY-P YSJM-A1(-BS)**



Model	16HP	18HP	20HP
Model Name	PURY-P400YSJM-A1(-BS)	PURY-P450YSJM-A1(-BS)	PURY-P500YSJM-A(-BS)

**R2 Series (20HP-24HP)** Page127

**PURY-P YSJM-A(-BS)**  
**PURY-P YSJM-A1(-BS)**



Model	20HP	22HP	24HP
Model Name	PURY-P500YSJM-A1(-BS)	PURY-P550YSJM-A(-BS)	PURY-P600YSJM-A(-BS)

**R2 Series (24HP-28HP)** Page128

**PURY-P YSJM-A(-BS)**  
**PURY-P YSJM-A1(-BS)**



Model	24HP	26HP	28HP
Model Name	PURY-P600YSJM-A1(-BS)	PURY-P650YSJM-A(-BS)	PURY-P700YSJM-A(-BS)

**R2 Series (28HP-32HP)** Page129

**PURY-P YSJM-A(-BS)**  
**PURY-P YSJM-A1(-BS)**



Model	28HP	30HP	32HP
Model Name	PURY-P700YSJM-A1(-BS)	PURY-P750YSJM-A(-BS)	PURY-P800YSJM-A(-BS)

**R2 Series (32HP-36HP)** Page130

**PURY-P YSJM-A(-BS)**  
**PURY-P YSJM-A1(-BS)**



Model	32HP	34HP	36HP
Model Name	PURY-P800YSJM-A1(-BS)	PURY-P850YSJM-A(-BS)	PURY-P900YSJM-A(-BS)

\* The PURY-P-YSJM-A(1) series requires a Twinning kit (optional). Refer to the data book for details.

# Wide selection of outdoor units

## Heat Recovery Series - High COP

**R2 Series - High COP (8HP-14HP) Page131**

**PURY-EP YJM-A(-BS)**



Model	8HP	10HP	12HP	14HP
Model Name	PURY-EP200YJM-A(-BS)	PURY-EP250YJM-A(-BS)	PURY-EP300YJM-A(-BS)	PURY-EP350YJM-A(-BS)

**R2 Series - High COP (16HP-20HP) Page132**

**PURY-EP YSJM-A(-BS)**



Model	16HP	18HP	20HP
Model Name	PURY-EP400YSJM-A(-BS)	PURY-EP450YSJM-A(-BS)	PURY-EP500YSJM-A(-BS)

**R2 Series - High COP (20HP-24HP) Page133**

**PURY-EP YSJM-A(-BS)**  
**PURY-EP YSJM-A1(-BS)**



Model	20HP	22HP	24HP
Model Name	PURY-EP500YSJM-A1(-BS)	PURY-EP550YSJM-A(-BS)	PURY-EP600YSJM-A(-BS)

**R2 Series - High COP (24HP-28HP) Page134**

**PURY-EP YSJM-A(-BS)**  
**PURY-EP YSJM-A1(-BS)**



Model	24HP	26HP	28HP
Model Name	PURY-EP600YSJM-A1(-BS)	PURY-EP650YSJM-A(-BS)	PURY-EP700YSJM-A(-BS)

## Water Cooled Heat Recovery Series

**WR2 (Heat Recovery) Series (8HP-24HP) Page135~137**

**PQRY-P YHM-A**  
**PQRY-P YSHM-A**



Model	8HP	10HP	12HP	16HP
Model Name	PQRY-P200YHM-A	PQRY-P250YHM-A	PQRY-P300YHM-A	PQRY-P400YSHM-A
Model	18HP	20HP	22HP	24HP
Model Name	PQRY-P450YSHM-A	PQRY-P500YSHM-A	PQRY-P550YSHM-A	PQRY-P600YSHM-A

\* The PURY-EP-YSJM-A(1) and PQRY-P-YSHM-A series requires a Twinning kit (optional). Refer to the data book for details.  
\* Unit photos are all standard models.

# OUTDOOR UNIT S Series PUMY-P VHMB(-BS)



## ► Specifications

		PUMY-P100VHMB(-BS)	PUMY-P125VHMB(-BS)	PUMY-P140VHMB(-BS)	
Power source		1-phase 220-230-240V 50Hz, 1-phase 220V 60Hz			
Cooling capacity (Nominal)	*1 kW	11.2	14.0	15.5	
	*1 BTU/h	38,200	47,800	52,900	
	Power input kW	3.34	4.32	5.35	
	Current input A	15.4-14.8-14.1, 15.4	20.0-19.1-18.3, 20.0	24.7-23.6-22.7, 24.7	
COP (kW/kW)		3.35	3.24	2.9	
Temp. range of cooling	Indoor W.B.	15 ~ 24°C (59 ~ 75°F)			
	Outdoor D.B.	- 5 ~ 46°C (23 ~ 115°F) 10 to 46°C D.B. (50 to 115°F D.B.) : in case of connecting PKFY-P15 / P20 / P25 type indoor unit.			
Heating capacity (Nominal)	*2 kW	12.5	16.0	18.0	
	*2 BTU/h	42,700	54,600	61,400	
	Power input kW	3.66	4.33	5.58	
	Current input A	16.9-16.2-15.5, 16.9	20.0-19.1-18.3, 20.0	25.8-24.7-23.6, 25.8	
COP (kW/kW)		3.42	3.69	3.23	
Temp. range of heating	Indoor temp. D.B.	15 ~ 27°C (59 ~ 81°F)			
	Outdoor temp. W.B.	-15 ~ 15°C (5 ~ 59°F)			
Indoor unit connectable	Total capacity	50 ~ 130% of outdoor unit capacity			
	Model/Quantity	P15 ~ P125 / 1 ~ 8	P15 ~ P140 / 1 ~ 10	P15 ~ P140 / 1 ~ 12	
Sound pressure level (measured in anechoic room)	dB<A>	49 / 51	50 / 52	51 / 53	
	Diameter of refrigerant pipe	mm(in.)	mm(in.)	mm(in.)	
External finish	Liquid (High press.)	ø9.52 (ø3/8)	ø9.52 (ø3/8)	ø9.52 (ø3/8)	
	Gas (Low press.)	ø15.88 (ø5/8)	ø15.88 (ø5/8)	ø15.88 (ø5/8)	
External dimension H x W x D		Galvanized steel sheet <MUNSELL 3Y 7.8/1.1>			
Net weight	mm (in.)	1,350 x 950 x 330 (53-3/16 x 37-7/16 x 13)	1,350 x 950 x 330 (53-3/16 x 37-7/16 x 13)	1,350 x 950 x 330 (53-3/16 x 37-7/16 x 13)	
	kg (lbs)	129 (284)	129 (284)	129 (284)	
Heat exchanger		Salt-resistant cross fin & copper tube			
Compressor	Type	Inverter scroll hermetic comp.			
	Starting method	Inverter			
FAN	Motor output kW	2.2	2.9	3.3	
	Air flow rate	m³/min	100	100	100
		L/s	1,667	1,667	1,667
	cfm	3,532	3,532	3,532	
Type x Quantity		Propeller fan x 2			
Motor output kW		0.06 x 2			
Protection	High pressure protection	High pressure sensor, High pressure switch 4.15 MPa			
	Inverter circuit (COMP./FAN)	Over-heat protection, Over-current protection			
	Compressor	Discharge thermo protection, Over-current protection			
Refrigerant	Type x Original charge	R410A x 8.5kg (19 lbs)			

### Notes:

\*1,\*2 Nominal conditions

	Indoor	Outdoor	Pipe length	Level difference
Cooling	27°C DB/19°C WB (81°F DB/66°F WB)	35°C DB(95°F DB)	7.5m (24-9/16ft.)	0m (0ft.)
Heating	20°C DB(68°F DB)	7°C DB/6°C WB(45°F DB/43°F WB)	7.5m (24-9/16ft.)	0m (0ft.)

\*Nominal condition \*1,\*2 are subject to JIS B8615-1.

\*Due to continuing improvement, above specification may be subject to change without notice.

# OUTDOOR UNIT S Series PUMY-P YHMB(-BS)



## ► Specifications

		PUMY-P100YHMB(-BS)	PUMY-P125YHMB(-BS)	PUMY-P140YHMB(-BS)
Power source		3-phase, 380-400-415V, 50Hz		
Cooling capacity (Nominal)	*1 kW	11.2	14.0	15.5
	*1 BTU/h	38,200	47,800	52,900
	Power input kW	3.30	4.27	5.32
	Current input A	5.28-5.02-4.84	6.83-6.49-6.26	8.51-8.09-7.80
COP (kW/kW)		3.39	3.28	2.91
Temp. range of cooling	Indoor W.B.	15 ~ 24°C (59~75°F)		
	Outdoor D.B.	- 5 ~ 46°C (23~115°F) 10 to 46°C D.B.(50 to 115°F D.B.) : in case of connecting PKFY-P15/P20/P25 type indoor unit.		
Heating capacity (Nominal)	*2 kW	12.5	16.0	18.0
	*2 BTU/h	42,700	54,600	61,400
	Power input kW	3.63	4.29	5.32
	Current input A	5.81-5.52-5.32	6.87-6.52-6.29	8.51-8.09-7.80
COP (kW/kW)		3.44	3.73	3.38
Temp. range of heating	Indoor temp. D.B.	15~27°C (59~81°F)		
	Outdoor temp. W.B.	-15~15°C (5~59°F)		
Indoor unit connectable	Total capacity	50 ~ 130% of outdoor unit capacity		
	Model/Quantity	P15 ~ P125 / 1 ~ 8	P15 ~ P140 / 1 ~ 10	P15 ~ P140 / 1 ~ 12
Sound pressure level (measured in anechoic room)	dB<A>	49/51	50/52	51/53
	Diameter of refrigerant pipe	Galvanized steel sheet<MUNSELL 3Y 7.8/1.1>		
External finish	External dimension H x W x D mm (in.)	1,350 x 950 x 330 (53-3/16 x 37-7/16 x 13)		
	Net weight kg (lbs)	142 (312)		
Heat exchanger		Salt-resistant cross fin & copper tube Inverter scroll hermetic compressor		
Compressor	Type	Mitsubishi Electric Corporation		
	Maker	Inverter		
	Starting method	Inverter		
	Motor output kW	1.9	2.4	2.9
FAN	Case heater kW	-		
	Lubricant	FV508		
	Air flow rate m <sup>3</sup> /min	100		
	External static press. Pa	0 Pa		
Control, Driving mechanism	Type x Quantity	Propeller fan x 2		
	Motor output kW	0.06 x 2		
Protection	HIC circuit (HIC: Heat Inter-Changer)	-		
	High pressure protection	High pressure sensor, High pressure switch 4.15 MPa		
	Inverter circuit (COMP./FAN)	Over-heat protection, Over-current protection		
	Compressor	Discharge thermo protection, Over-current protection		
Defrosting method	Fan motor	Over-heat protection, Voltage protection		
	Auto-defrost mode (Reversed refrigerant circle)			
Refrigerant	Type x Original charge	R410A x 8.5kg (19 lbs)		
	Control	LEV circuit		

### Notes:

\*1,\*2 Nominal conditions

	Indoor	Outdoor	Pipe length	Level difference
Cooling	27°C DB/19°C WB (81°F DB/66°F WB)	35°C DB(95°F DB)	7.5m (24-9/16ft.)	0m (0ft.)
Heating	20°C DB(68°F DB)	7°C DB/6°C WB(45°F DB/43°F WB)	7.5m (24-9/16ft.)	0m (0ft.)

\*Nominal condition \*1,\*2 are subject to JIS B8615-1.

\*Due to continuing improvement, above specification may be subject to change without notice.

# OUTDOOR UNIT Y Series PUHY-P YJM-A(-BS)



## ► Specifications

Model		PUHY-P200YJM-A(-BS)	PUHY-P250YJM-A(-BS)	PUHY-P300YJM-A(-BS)
Power source		3-phase 4-wire 380-400-415V 50/60Hz		
Cooling capacity (Nominal)	*1 kW	22.4	28.0	33.5
	*1 BTU/h	76,400	95,500	114,300
	Power input kW	5.62	7.40	9.00
	Current input A	9.4-9.0-8.6	12.4-11.8-11.4	15.1-14.4-13.9
COP		3.98	3.78	3.72
Temp. range of cooling	Indoor W.B.	15.0~24.0°C(59~75°F)		
	Outdoor D.B.	-5.0~46.0°C(23~115°F)		
Heating capacity (Nominal)	*2 kW	25.0	31.5	37.5
	*2 BTU/h	85,300	107,500	128,000
	Power input kW	5.84	7.34	9.25
	Current input A	9.8-9.3-9.0	12.3-11.7-11.3	15.6-14.8-14.2
COP		4.28	4.29	4.05
Temp. range of heating	Indoor D.B.	15.0~27.0°C(59~81°F)		
	Outdoor W.B.	-20.0~15.5°C(-4~60°F)		
Indoor unit connectable	Total capacity	50~130 % of outdoor unit capacity		
	Model / Quantity	P15~P250 / 1~17	P15~P250 / 1~21	P15~P250 / 1~26
Sound pressure level (measured in anechoic room)	dB <A>	56	58	59
	Power pressure level (measured in anechoic room)	76	78	79
Refrigerant piping diameter	Liquid pipe mm (in.)	9.52(3/8) Braze	9.52(3/8) Braze (12.7(1/2) Braze, total length >= 90m)	9.52(3/8) Braze (12.7(1/2) Braze, total length >= 40m)
	Gas pipe mm (in.)	19.05(3/4) Braze	22.2(7/8) Braze	22.2(7/8) Braze
FAN	Type x Quantity	Propeller fan x 1		
	Air flow rate m <sup>3</sup> /min	170		
	L/s	2,833		
	cfm	6,003		
Driving mechanism	Type x Quantity	Inverter-control, Direct-driven by motor		
	Motor output kW	0.46 x 1		
	External static press.	0 Pa (0 mmH <sub>2</sub> O)		
	Compressor	Inverter scroll hermetic compressor		
Compressor	Type x Quantity	Inverter scroll hermetic compressor		
	Starting method	Inverter		
	Motor output kW	6.8		
	Case heater kW	0.035		
External finish	External dimension HxWxD mm	1,710(1,650 without legs) x 920 x 760	1,710(1,650 without legs) x 920 x 760	1,710(1,650 without legs) x 920 x 760
	in.	67-3/8(65 without legs) x 36-1/4 x 29-15/16	67-3/8(65 without legs) x 36-1/4 x 29-15/16	67-3/8(65 without legs) x 36-1/4 x 29-15/16
Protection devices	High pressure protection	High pressure sensor, High pressure switch at 4.15MPa (601 psi)	High pressure sensor, High pressure switch at 4.15MPa (601 psi)	High pressure sensor, High pressure switch at 4.15MPa (601 psi)
	Inverter circuit (COMP./FAN)	Over-heat protection, Over-current protection	Over-heat protection, Over-current protection	Over-heat protection, Over-current protection
	Compressor	Over-heat protection	Over-heat protection	Over-heat protection
	Fan motor	Thermal switch	Thermal switch	Thermal switch
Refrigerant	Type x original charge	R410A x 6.5kg (14lbs)	R410A x 8.0kg (18lbs)	R410A x 8.0kg (18lbs)
	Net weight kg (lbs)	190(419)	200(441)	215(474)
Heat exchanger		Salt-resistant cross fin & copper tube		
Optional parts		Joint: CMY-Y102SS-G2 Header: CMY-Y104/108/1010-G		

### Notes:

\*1,\*2 Nominal conditions

	Indoor	Outdoor	Pipe length	Level difference
Cooling	27°C DB/19°C WB (81°F DB/66°F WB)	35°C DB(95°F DB)	7.5m (24-9/16ft.)	0m (0ft.)
Heating	20°C DB(68°F DB)	7°C DB/6°C WB(45°F DB/43°F WB)	7.5m (24-9/16ft.)	0m (0ft.)

\*3 External static pressure option is available (30Pa, 60Pa / 3.1mmH<sub>2</sub>O, 6.1mmH<sub>2</sub>O).

\*Nominal condition \*1,\*2 are subject to JIS B8615-1.

\*Due to continuing improvement, above specification may be subject to change without notice.

# OUTDOOR UNIT Y Series PUHY-P YJM-A(-BS)



## > Specifications

Model	PUHY-P350YJM-A(-BS)		PUHY-P400YJM-A(-BS)		PUHY-P450YJM-A(-BS)		
Power source	3-phase 4-wire 380-400-415V 50/60Hz		3-phase 4-wire 380-400-415V 50/60Hz		3-phase 4-wire 380-400-415V 50/60Hz		
Cooling capacity (Nominal)	*1 kW	40.0	45.0	50.0	50.0	50.0	
	*1 BTU / h	136,500	153,500	170,600	170,600	170,600	
	Power input kW	11.01	13.11	15.47	15.47	15.47	
	Current input A	18.5-17.6-17.0	22.1-21.0-20.2	26.1-24.8-23.9	26.1-24.8-23.9	26.1-24.8-23.9	
	COP kW / kW	3.63	3.43	3.23	3.23	3.23	
Temp. range of cooling	Indoor W.B.	15.0~24.0°C(59~75°F)	15.0~24.0°C(59~75°F)	15.0~24.0°C(59~75°F)	15.0~24.0°C(59~75°F)	15.0~24.0°C(59~75°F)	
	Outdoor D.B.	-5.0~46.0°C(23~115°F)	-5.0~46.0°C(23~115°F)	-5.0~46.0°C(23~115°F)	-5.0~46.0°C(23~115°F)	-5.0~46.0°C(23~115°F)	
Heating capacity (Nominal)	*2 kW	45.0	50.0	56.0	56.0	56.0	
	*2 BTU / h	153,500	170,600	191,100	191,100	191,100	
	Power input kW	11.19	12.82	14.62	14.62	14.62	
	Current input A	18.8-17.9-17.2	21.6-20.5-19.8	24.6-23.4-22.5	24.6-23.4-22.5	24.6-23.4-22.5	
	COP kW / kW	4.02	3.90	3.83	3.83	3.83	
Temp. range of heating	Indoor W.B.	15.0~27.0°C(59~81°F)	15.0~27.0°C(59~81°F)	15.0~27.0°C(59~81°F)	15.0~27.0°C(59~81°F)	15.0~27.0°C(59~81°F)	
	Outdoor W.B.	-20.0~15.5°C(-4~60°F)	-20.0~15.5°C(-4~60°F)	-20.0~15.5°C(-4~60°F)	-20.0~15.5°C(-4~60°F)	-20.0~15.5°C(-4~60°F)	
Indoor unit connectable	50~130 % of outdoor unit capacity		50~130 % of outdoor unit capacity		50~130 % of outdoor unit capacity		
Model / Quantity	P15~P250 / 1~30		P15~P250 / 1~34		P15~P250 / 1~39		
Sound pressure level (measured in anechoic room)	dB <A>	60	61	62	62	62	
Power pressure level (measured in anechoic room)	dB <A>	80	81	82	82	82	
Refrigerant piping diameter	Liquid pipe mm (in.)	12.7(1/2) Braze	12.7(1/2) Braze	15.88(5/8) Braze	15.88(5/8) Braze	15.88(5/8) Braze	
	Gas pipe mm (in.)	28.58(1-1/8) Braze	28.58(1-1/8) Braze	28.58(1-1/8) Braze	28.58(1-1/8) Braze	28.58(1-1/8) Braze	
FAN	Type x Quantity	Propeller fan x 1		Propeller fan x 2		Propeller fan x 2	
	Air flow rate m³/min	210		370		370	
	L/s	3,500		6,167		6,167	
	cfm	7,415		13,065		13,065	
	Driving mechanism	Inverter-control, Direct-driven by motor		Inverter-control, Direct-driven by motor		Inverter-control, Direct-driven by motor	
	Motor output kW	0.46 x 1		0.46 x 1		0.46 x 2	
	*3 External static press.	0 Pa (0 mmH <sub>2</sub> O)		0 Pa (0 mmH <sub>2</sub> O)		0 Pa (0 mmH <sub>2</sub> O)	
	Type x Quantity	Inverter scroll hermetic compressor		Inverter scroll hermetic compressor		Inverter scroll hermetic compressor	
Starting method	Inverter		Inverter		Inverter		
Motor output kW	9.9		10.1		11.6		
Case heater kW	0.045		0.045		0.045		
External finish	Pre-coated galvanized steel sheets (+powder coating for -BS type) <MUNSELL 5Y 8/1 or similar>		Pre-coated galvanized steel sheets (+powder coating for -BS type) <MUNSELL 5Y 8/1 or similar>		Pre-coated galvanized steel sheets (+powder coating for -BS type) <MUNSELL 5Y 8/1 or similar>		
External dimension HxWxD	mm	1,710(1,650 without legs) x 1,220 x 760		1,710(1,650 without legs) x 1,220 x 760		1,710(1,650 without legs) x 1,750 x 760	
	in.	67-3/8(65 without legs) x 48-1/16 x 29-15/16		67-3/8(65 without legs) x 48-1/16 x 29-15/16		67-3/8(65 without legs) x 68-15/16 x 29-15/16	
Protection devices	High pressure protection	High pressure sensor, High pressure switch at 4.15MPa (601 psi)		High pressure sensor, High pressure switch at 4.15MPa (601 psi)		High pressure sensor, High pressure switch at 4.15MPa (601 psi)	
	Inverter circuit (COMP./FAN)	Over-heat protection, Over-current protection		Over-heat protection, Over-current protection		Over-heat protection, Over-current protection	
	Compressor	Over-heat protection		Over-heat protection		Over-heat protection	
Refrigerant	Type x original charge	R410A x 11.5kg (26lbs)		R410A x 11.5kg (26lbs)		R410A x 11.8kg (27lbs)	
	Net weight kg (lbs)	250(552)		250(552)		290(640)	
Heat exchanger	Salt-resistant cross fin & copper tube		Salt-resistant cross fin & copper tube		Salt-resistant cross fin & copper tube		
Optional parts	Joint: CMY-Y102SS/LS-G2, CMY-Y202S-G2 Header: CMY-Y104/108/1010-G		Joint: CMY-Y102SS/LS-G2, CMY-Y202S-G2 Header: CMY-Y104/108/1010-G		Joint: CMY-Y102SS/LS-G2, CMY-Y202S-G2 Header: CMY-Y104/108/1010-G		

### Notes:

\*1,\*2 Nominal conditions

	Indoor	Outdoor	Pipe length	Level difference
Cooling	27°C DB/19°C WB (81°F DB/66°F WB)	35°C DB(95°F DB)	7.5m (24-9/16ft.)	0m (0ft.)
Heating	20°C DB(68°F DB)	7°C DB/6°C WB(45°F DB/43°F WB)	7.5m (24-9/16ft.)	0m (0ft.)

\*3 External static pressure option is available (30Pa, 60Pa / 3.1mmH<sub>2</sub>O, 6.1mmH<sub>2</sub>O).

\*Nominal condition \*1,\*2 are subject to JIS B8615-1.

\*Due to continuing improvement, above specification may be subject to change without notice.

Outdoor unit

# OUTDOOR UNIT Y Series PUHY-P YSJM-A(1)(-BS)



## > Specifications

Model	PUHY-P500YSJM-A(-BS)		PUHY-P500YSJM-A1(-BS)		PUHY-P550YSJM-A(-BS)		PUHY-P600YSJM-A1(-BS)		
Power source	3-phase 4-wire 380-400-415V 50/60Hz		3-phase 4-wire 380-400-415V 50/60Hz		3-phase 4-wire 380-400-415V 50/60Hz		3-phase 4-wire 380-400-415V 50/60Hz		
Cooling capacity (Nominal)	*1 kW	56.0	56.0	56.0	63.0	63.0	69.0	69.0	
	*1 BTU / h	191,100	191,100	191,100	215,000	215,000	235,400	235,400	
	Power input kW	15.38	15.05	15.05	17.16	17.16	19.00	19.00	
	Current input A	25.9-24.6-23.7	25.4-24.1-23.2	25.4-24.1-23.2	28.9-27.5-26.5	28.9-27.5-26.5	32.0-30.4-29.3	32.0-30.4-29.3	
	COP kW / kW	3.64	3.72	3.72	3.67	3.67	3.63	3.63	
Temp. range of cooling	Indoor W.B.	15.0~24.0°C(59~75°F)	15.0~24.0°C(59~75°F)	15.0~24.0°C(59~75°F)	15.0~24.0°C(59~75°F)	15.0~24.0°C(59~75°F)	15.0~24.0°C(59~75°F)	15.0~24.0°C(59~75°F)	
	Outdoor D.B.	-5.0~46.0°C(23~115°F)	-5.0~46.0°C(23~115°F)	-5.0~46.0°C(23~115°F)	-5.0~46.0°C(23~115°F)	-5.0~46.0°C(23~115°F)	-5.0~46.0°C(23~115°F)	-5.0~46.0°C(23~115°F)	
Heating capacity (Nominal)	*2 kW	63.0	63.0	63.0	69.0	69.0	76.5	76.5	
	*2 BTU / h	215,000	215,000	215,000	235,400	235,400	261,000	261,000	
	Power input kW	15.03	15.51	15.51	16.87	16.87	19.26	19.26	
	Current input A	25.3-24.1-23.2	26.1-24.8-23.9	26.1-24.8-23.9	28.4-27.0-26.0	28.4-27.0-26.0	32.5-30.8-29.7	32.5-30.8-29.7	
	COP kW / kW	4.19	4.06	4.06	4.09	4.09	3.97	3.97	
Temp. range of heating	Indoor D.B.	15.0~27.0°C(59~81°F)	15.0~27.0°C(59~81°F)	15.0~27.0°C(59~81°F)	15.0~27.0°C(59~81°F)	15.0~27.0°C(59~81°F)	15.0~27.0°C(59~81°F)	15.0~27.0°C(59~81°F)	
	Outdoor W.B.	-20.0~15.5°C(-4~60°F)	-20.0~15.5°C(-4~60°F)	-20.0~15.5°C(-4~60°F)	-20.0~15.5°C(-4~60°F)	-20.0~15.5°C(-4~60°F)	-20.0~15.5°C(-4~60°F)	-20.0~15.5°C(-4~60°F)	
Indoor unit connectable	50~130 % of outdoor unit capacity		50~130 % of outdoor unit capacity		50~130 % of outdoor unit capacity		50~130 % of outdoor unit capacity		
Model / Quantity	P15~P250 / 1~43		P15~P250 / 1~43		P15~P250 / 1~47		P15~P250 / 1~50		
Sound pressure level (measured in anechoic room)	dB <A>	61	61	61	61.5	61.5	62	62	
Power pressure level (measured in anechoic room)	dB <A>	81	81	81	81.5	81.5	82	82	
Refrigerant piping diameter	Liquid pipe mm (in.)	15.88(5/8) Braze	15.88(5/8) Braze	15.88(5/8) Braze	15.88(5/8) Braze	15.88(5/8) Braze	15.88(5/8) Braze	15.88(5/8) Braze	
	Gas pipe mm (in.)	28.58(1-1/8) Braze	28.58(1-1/8) Braze	28.58(1-1/8) Braze	28.58(1-1/8) Braze	28.58(1-1/8) Braze	28.58(1-1/8) Braze	28.58(1-1/8) Braze	
<b>Set Model</b>									
Model	PUHY-P250YJM-A(-BS)	PUHY-P250YJM-A(-BS)	PUHY-P200YJM-A(-BS)	PUHY-P300YJM-A(-BS)	PUHY-P250YJM-A(-BS)	PUHY-P300YJM-A(-BS)	PUHY-P300YJM-A(-BS)	PUHY-P300YJM-A(-BS)	
FAN	Type x Quantity	Propeller fan x 1		Propeller fan x 1		Propeller fan x 1		Propeller fan x 1	
	Air flow rate m³/min	170		170		170		170	
	L/s	2,833		2,833		2,833		2,833	
	cfm	6,003		6,003		6,003		6,003	
	Driving mechanism	Inverter-control, Direct-driven by motor		Inverter-control, Direct-driven by motor		Inverter-control, Direct-driven by motor		Inverter-control, Direct-driven by motor	
	Motor output kW	0.46 x 1		0.46 x 1		0.46 x 1		0.46 x 1	
	*3 External static press.	0 Pa (0 mmH <sub>2</sub> O)		0 Pa (0 mmH <sub>2</sub> O)		0 Pa (0 mmH <sub>2</sub> O)		0 Pa (0 mmH <sub>2</sub> O)	
	Type x Quantity	Inverter scroll hermetic compressor		Inverter scroll hermetic compressor		Inverter scroll hermetic compressor		Inverter scroll hermetic compressor	
Starting method	Inverter		Inverter		Inverter		Inverter		
Motor output kW	6.8		6.8		7.7		7.7		
Case heater kW	0.035		0.035		0.045		0.045		
External finish	Pre-coated galvanized steel sheets (+powder coating for -BS type) <MUNSELL 5Y 8/1 or similar>		Pre-coated galvanized steel sheets (+powder coating for -BS type) <MUNSELL 5Y 8/1 or similar>		Pre-coated galvanized steel sheets (+powder coating for -BS type) <MUNSELL 5Y 8/1 or similar>		Pre-coated galvanized steel sheets (+powder coating for -BS type) <MUNSELL 5Y 8/1 or similar>		
External dimension HxWxD	mm	1,710(1,650 without legs) x 920 x 760		1,710(1,650 without legs) x 920 x 760		1,710(1,650 without legs) x 920 x 760		1,710(1,650 without legs) x 920 x 760	
	in.	67-3/8(65 without legs) x 36-1/4 x 29-15/16		67-3/8(65 without legs) x 36-1/4 x 29-15/16		67-3/8(65 without legs) x 36-1/4 x 29-15/16		67-3/8(65 without legs) x 36-1/4 x 29-15/16	
Protection devices	High pressure protection	High pressure sensor, High pressure switch at 4.15MPa (601 psi)		High pressure sensor, High pressure switch at 4.15MPa (601 psi)		High pressure sensor, High pressure switch at 4.15MPa (601 psi)		High pressure sensor, High pressure switch at 4.15MPa (601 psi)	
	Inverter circuit (COMP./FAN)	Over-heat protection, Over-current protection		Over-heat protection, Over-current protection		Over-heat protection, Over-current protection		Over-heat protection, Over-current protection	
	Compressor	Over-heat protection		Over-heat protection		Over-heat protection		Over-heat protection	
Refrigerant	Type x original charge	R410A x 8.0kg (18lbs)		R410A x 8.0kg (18lbs)		R410A x 8.0kg (18lbs)		R410A x 8.0kg (18lbs)	
	Net weight kg (lbs)	200(441)		200(441)		200(441)		215(474)	
Heat exchanger	Salt-resistant cross fin & copper tube		Salt-resistant cross fin & copper tube		Salt-resistant cross fin & copper tube		Salt-resistant cross fin & copper tube		
Pipe between unit and distributor	Liquid pipe mm (in.)	9.52(3/8) Braze		9.52(3/8) Braze		9.52(3/8) Braze		9.52(3/8) Braze	
	Gas pipe mm (in.)	22.2(7/8) Braze		22.2(7/8) Braze		22.2(7/8) Braze		22.2(7/8) Braze	
Optional parts	Outdoor Twinning kit: CMY-Y100VBK2 Joint: CMY-Y102SS/LS-G2, CMY-Y202S-G2 Header: CMY-Y104/108/1010-G		Outdoor Twinning kit: CMY-Y100VBK2 Joint: CMY-Y102SS/LS-G2, CMY-Y202S-G2 Header: CMY-Y104/108/1010-G		Outdoor Twinning kit: CMY-Y100VBK2 Joint: CMY-Y102SS/LS-G2, CMY-Y202S/302S-G2 Header: CMY-Y104/108/1010-G		Outdoor Twinning kit: CMY-Y100VBK2 Joint: CMY-Y102SS/LS-G2, CMY-Y202S/302S-G2 Header: CMY-Y104/108/1010-G		

### Notes:

\*1,\*2 Nominal conditions

	Indoor	Outdoor	Pipe length	Level difference
Cooling	27°C DB/19°C WB (81°F DB/66°F WB)	35°C DB(95°F DB)	7.5m (24-9/16ft.)	0m (0ft.)
Heating	20°C DB(68°F DB)	7°C DB/6°C WB(45°F DB/43°F WB)	7.5m (24-9/16ft.)	0m (0ft.)

\*3 External static pressure option is available (30Pa, 60Pa / 3.1mmH<sub>2</sub>O, 6.1mmH<sub>2</sub>O).

\*Nominal condition \*1,\*2 are subject to JIS B8615-1.

\*Due to continuing improvement, above specification may be subject to change without notice.

Outdoor Unit

# OUTDOOR UNIT Y Series PUHY-P YSJM-A(1)(-BS)



## ► Specifications

Model	PUHY-P600YSJM-A(-BS)	PUHY-P650YSJM-A(-BS)	PUHY-P700YSJM-A(-BS)	
Power source	3-phase 4-wire 380-400-415V 50/60Hz			
Cooling capacity (Nominal)	*1 kW	69.0	73.0	80.0
	*1 BTU/h	235,400	249,100	273,000
	Power input kW	18.75	20.39	23.05
	Current input A	31.6-30.0-28.9	34.4-32.7-31.5	38.9-36.9-35.6
	COP	3.68	3.58	3.47
Temp. range of cooling	Indoor W.B.	15.0~24.0°C(59~75°F)	15.0~24.0°C(59~75°F)	15.0~24.0°C(59~75°F)
	Outdoor D.B.	-5.0~46.0°C(23~115°F)	-5.0~46.0°C(23~115°F)	-5.0~46.0°C(23~115°F)
Heating capacity (Nominal)	*2 kW	76.5	81.5	88.0
	*2 BTU/h	261,000	278,100	300,300
	Power input kW	18.88	20.47	23.09
	Current input A	31.8-30.2-29.1	34.5-32.8-31.6	38.9-37.0-35.6
	COP	4.05	3.98	3.81
Temp. range of heating	Indoor W.B.	15.0~27.0°C(59~81°F)	15.0~27.0°C(59~81°F)	15.0~27.0°C(59~81°F)
	Outdoor W.B.	-20.0~15.5°C(-4~60°F)	-20.0~15.5°C(-4~60°F)	-20.0~15.5°C(-4~60°F)
Indoor unit connectable	Total capacity	50~130 % of outdoor unit capacity	50~130 % of outdoor unit capacity	50~130 % of outdoor unit capacity
	Model / Quantity	P15~P250 / 1~50	P15~P250 / 1~50	P15~P250 / 1~50
Sound pressure level (measured in anechoic room)	dB <A>	62	62.5	63
Power pressure level (measured in anechoic room)	dB <A>	82	82.5	83
Refrigerant piping diameter	Liquid pipe mm (in.)	15.88(5/8) Braze	15.88(5/8) Braze	19.05(3/4) Braze
	Gas pipe mm (in.)	28.58(1-1/8) Braze	28.58(1-1/8) Braze	34.93(1-3/8) Braze

Set Model		PUHY-P250YJM-A(-BS)	PUHY-P350YJM-A(-BS)	PUHY-P300YJM-A(-BS)	PUHY-P350YJM-A(-BS)	PUHY-P400YJM-A(-BS)	PUHY-P400YJM-A(-BS)		
FAN	Type x Quantity	Propeller fan x 1		Propeller fan x 1		Propeller fan x 1			
	Air flow rate	m³/min	170	210	170	210	170	210	
		L/s	2,833	3,500	2,833	3,500	2,833	3,500	
		cfm	6,003	7,415	6,003	7,415	6,003	7,415	
	Driving mechanism	Inverter-control, Direct-driven by motor		Inverter-control, Direct-driven by motor		Inverter-control, Direct-driven by motor		Inverter-control, Direct-driven by motor	
	Motor output kW	0.46 x 1		0.46 x 1		0.46 x 1		0.46 x 1	
	*3 External static press.	0 Pa (0 mmH <sub>2</sub> O)		0 Pa (0 mmH <sub>2</sub> O)		0 Pa (0 mmH <sub>2</sub> O)		0 Pa (0 mmH <sub>2</sub> O)	
	Compressor	Type x Quantity	Inverter scroll hermetic compressor		Inverter scroll hermetic compressor		Inverter scroll hermetic compressor		
		Starting method	Inverter		Inverter		Inverter		
		Motor output kW	6.8		9.9		10.1		
Case heater kW		0.035		0.045		0.045			
External finish	Pre-coated galvanized steel sheets (+powder coating for -BS type) <MUNSELL 5Y 8/1 or similar>		Pre-coated galvanized steel sheets (+powder coating for -BS type) <MUNSELL 5Y 8/1 or similar>		Pre-coated galvanized steel sheets (+powder coating for -BS type) <MUNSELL 5Y 8/1 or similar>		Pre-coated galvanized steel sheets (+powder coating for -BS type) <MUNSELL 5Y 8/1 or similar>		
	External dimension HxWxD	mm	1,710(1,650 without legs) x 920 x 760	1,710(1,650 without legs) x 1,220 x 760	1,710(1,650 without legs) x 920 x 760	1,710(1,650 without legs) x 1,220 x 760	1,710(1,650 without legs) x 920 x 760	1,710(1,650 without legs) x 1,220 x 760	
Protection devices	High pressure protection	High pressure sensor, High pressure switch at 4.15MPa (601 psi)		High pressure sensor, High pressure switch at 4.15MPa (601 psi)		High pressure sensor, High pressure switch at 4.15MPa (601 psi)		High pressure sensor, High pressure switch at 4.15MPa (601 psi)	
		Inverter circuit (COMP./FAN)		Over-heat protection, Over-current protection		Over-heat protection, Over-current protection		Over-heat protection, Over-current protection	
	Compressor	Over-heat protection		Over-heat protection		Over-heat protection		Over-heat protection	
		Fan motor		Thermal switch		Thermal switch		Thermal switch	
Refrigerant	Type x original charge	R410A x 8.0kg (18lbs)	R410A x 11.5kg (26lbs)	R410A x 8.0kg (18lbs)	R410A x 11.5kg (26lbs)	R410A x 8.0kg (18lbs)	R410A x 11.5kg (26lbs)	R410A x 8.0kg (18lbs)	R410A x 11.5kg (26lbs)
Net weight	kg (lbs)	200(441)	250(552)	215(474)	250(552)	215(474)	250(552)	215(474)	250(552)
Heat exchanger	Salt-resistant cross fin & copper tube		Salt-resistant cross fin & copper tube		Salt-resistant cross fin & copper tube		Salt-resistant cross fin & copper tube		
	Pipe between unit and distributor	Liquid pipe mm (in.)	9.52(3/8) Braze	12.7(1/2) Braze	12.7(1/2) Braze	12.7(1/2) Braze	15.88(5/8) Braze	15.88(5/8) Braze	
Optional parts	Outdoor Twinning kit: CMY-Y100VBK2		Outdoor Twinning kit: CMY-Y100VBK2		Outdoor Twinning kit: CMY-Y100VBK2		Outdoor Twinning kit: CMY-Y100VBK2		
	Joint: CMY-Y102SS/LS-G2, CMY-Y202S/302S-G2		Header: CMY-Y104/108/1010-G		Joint: CMY-Y102SS/LS-G2, CMY-Y202S/302S-G2		Header: CMY-Y104/108/1010-G		

### Notes:

\*1,\*2 Nominal conditions

	Indoor	Outdoor	Pipe length	Level difference
Cooling	27°C DB/19°C WB (81°F DB/66°F WB)	35°C DB(95°F DB)	7.5m (24-9/16ft.)	0m (0ft.)
Heating	20°C DB(68°F DB)	7°C DB/6°C WB(45°F DB/43°F WB)	7.5m (24-9/16ft.)	0m (0ft.)

\*3 External static pressure option is available (30Pa, 60Pa / 3.1mmH<sub>2</sub>O, 6.1mmH<sub>2</sub>O).  
 \*Nominal condition \*1,\*2 are subject to JIS B8615-1.  
 \*Due to continuing improvement, above specification may be subject to change without notice.

Outdoor unit

# OUTDOOR UNIT Y Series PUHY-P YSJM-A(1)(-BS)



## ► Specifications

Model	PUHY-P700YSJM-A(-BS)	PUHY-P750YSJM-A(-BS)	PUHY-P800YSJM-A(-BS)	
Power source	3-phase 4-wire 380-400-415V 50/60Hz			
Cooling capacity (Nominal)	*1 kW	80.0	85.0	90.0
	*1 BTU/h	273,000	290,000	307,100
	Power input kW	22.47	24.70	26.86
	Current input A	37.9-36.0-34.7	41.6-39.6-38.1	45.3-43.0-41.5
	COP	3.56	3.44	3.35
Temp. range of cooling	Indoor W.B.	15.0~24.0°C(59~75°F)	15.0~24.0°C(59~75°F)	15.0~24.0°C(59~75°F)
	Outdoor D.B.	-5.0~46.0°C(23~115°F)	-5.0~46.0°C(23~115°F)	-5.0~46.0°C(23~115°F)
Heating capacity (Nominal)	*2 kW	88.0	95.0	100.0
	*2 BTU/h	300,300	324,100	341,200
	Power input kW	22.27	24.67	27.02
	Current input A	37.5-35.7-34.4	41.6-39.5-38.1	45.6-43.3-41.7
	COP	3.95	3.85	3.70
Temp. range of heating	Indoor W.B.	15.0~27.0°C(59~81°F)	15.0~27.0°C(59~81°F)	15.0~27.0°C(59~81°F)
	Outdoor W.B.	-20.0~15.5°C(-4~60°F)	-20.0~15.5°C(-4~60°F)	-20.0~15.5°C(-4~60°F)
Indoor unit connectable	Total capacity	50~130 % of outdoor unit capacity	50~130 % of outdoor unit capacity	50~130 % of outdoor unit capacity
	Model / Quantity	P15~P250 / 1~50	P15~P250 / 1~50	P15~P250 / 1~50
Sound pressure level (measured in anechoic room)	dB <A>	63	63.5	64
Power pressure level (measured in anechoic room)	dB <A>	83	83.5	84
Refrigerant piping diameter	Liquid pipe mm (in.)	19.05(3/4) Braze	19.05(3/4) Braze	19.05(3/4) Braze
	Gas pipe mm (in.)	34.93(1-3/8) Braze	34.93(1-3/8) Braze	34.93(1-3/8) Braze

Set Model		PUHY-P350YJM-A(-BS)	PUHY-P350YJM-A(-BS)	PUHY-P350YJM-A(-BS)	PUHY-P400YJM-A(-BS)	PUHY-P400YJM-A(-BS)	PUHY-P400YJM-A(-BS)		
FAN	Type x Quantity	Propeller fan x 1		Propeller fan x 1		Propeller fan x 1			
	Air flow rate	m³/min	210	210	210	210	210	210	
		L/s	3,500	3,500	3,500	3,500	3,500	3,500	
		cfm	7,415	7,415	7,415	7,415	7,415	7,415	
	Driving mechanism	Inverter-control, Direct-driven by motor		Inverter-control, Direct-driven by motor		Inverter-control, Direct-driven by motor		Inverter-control, Direct-driven by motor	
	Motor output kW	0.46 x 1		0.46 x 1		0.46 x 1		0.46 x 1	
	*3 External static press.	0 Pa (0 mmH <sub>2</sub> O)		0 Pa (0 mmH <sub>2</sub> O)		0 Pa (0 mmH <sub>2</sub> O)		0 Pa (0 mmH <sub>2</sub> O)	
	Compressor	Type x Quantity	Inverter scroll hermetic compressor		Inverter scroll hermetic compressor		Inverter scroll hermetic compressor		
		Starting method	Inverter		Inverter		Inverter		
		Motor output kW	9.9		9.9		10.1		
Case heater kW		0.045		0.045		0.045			
External finish	Pre-coated galvanized steel sheets (+powder coating for -BS type) <MUNSELL 5Y 8/1 or similar>		Pre-coated galvanized steel sheets (+powder coating for -BS type) <MUNSELL 5Y 8/1 or similar>		Pre-coated galvanized steel sheets (+powder coating for -BS type) <MUNSELL 5Y 8/1 or similar>		Pre-coated galvanized steel sheets (+powder coating for -BS type) <MUNSELL 5Y 8/1 or similar>		
	External dimension HxWxD	mm	1,710(1,650 without legs) x 1,220 x 760	1,710(1,650 without legs) x 1,220 x 760	1,710(1,650 without legs) x 1,220 x 760	1,710(1,650 without legs) x 1,220 x 760	1,710(1,650 without legs) x 1,220 x 760	1,710(1,650 without legs) x 1,220 x 760	
Protection devices	High pressure protection	High pressure sensor, High pressure switch at 4.15MPa (601 psi)		High pressure sensor, High pressure switch at 4.15MPa (601 psi)		High pressure sensor, High pressure switch at 4.15MPa (601 psi)		High pressure sensor, High pressure switch at 4.15MPa (601 psi)	
		Inverter circuit (COMP./FAN)		Over-heat protection, Over-current protection		Over-heat protection, Over-current protection		Over-heat protection, Over-current protection	
	Compressor	Over-heat protection		Over-heat protection		Over-heat protection		Over-heat protection	
		Fan motor		Thermal switch		Thermal switch		Thermal switch	
Refrigerant	Type x original charge	R410A x 11.5kg (26lbs)	R410A x 11.5kg (26lbs)	R410A x 11.5kg (26lbs)	R410A x 11.5kg (26lbs)	R410A x 11.5kg (26lbs)	R410A x 11.5kg (26lbs)	R410A x 11.5kg (26lbs)	
Net weight	kg (lbs)	250(552)	250(552)	250(552)	250(552)	250(552)	250(552)		
Heat exchanger	Salt-resistant cross fin & copper tube		Salt-resistant cross fin & copper tube		Salt-resistant cross fin & copper tube		Salt-resistant cross fin & copper tube		
	Pipe between unit and distributor	Liquid pipe mm (in.)	12.7(1/2) Braze	12.7(1/2) Braze	12.7(1/2) Braze	15.88(5/8) Braze	15.88(5/8) Braze		
Optional parts	Outdoor Twinning kit: CMY-Y200VBK2		Outdoor Twinning kit: CMY-Y200VBK2		Outdoor Twinning kit: CMY-Y200VBK2		Outdoor Twinning kit: CMY-Y200VBK2		
	Joint: CMY-Y102SS/LS-G2, CMY-Y202S/302S-G2		Header: CMY-Y104/108/1010-G		Joint: CMY-Y102SS/LS-G2, CMY-Y202S/302S-G2		Header: CMY-Y104/108/1010-G		

### Notes:

\*1,\*2 Nominal conditions

	Indoor	Outdoor	Pipe length	Level difference
Cooling	27°C DB/19°C WB (81°F DB/66°F WB)	35°C DB(95°F DB)	7.5m (24-9/16ft.)	0m (0ft.)
Heating	20°C DB(68°F DB)	7°C DB/6°C WB(45°F DB/43°F WB)	7.5m (24-9/16ft.)	0m (0ft.)

\*3 External static pressure option is available (30Pa, 60Pa / 3.1mmH<sub>2</sub>O, 6.1mmH<sub>2</sub>O).  
 \*Nominal condition \*1,\*2 are subject to JIS B8615-1.  
 \*Due to continuing improvement, above specification may be subject to change without notice.

Outdoor Unit

# OUTDOOR UNIT Y Series PUHY-P YSJM-A (-BS)

## ► Specifications



Model	PUHY-P800YSJM-A(-BS)		PUHY-P850YSJM-A(-BS)		PUHY-P900YSJM-A(-BS)		
Power source	3-phase 4-wire 380-400-415V 50/60Hz						
Cooling capacity (Nominal)	*1 kW	90.0		96.0		101.0	
	*1 BTU / h	307,100		327,600		344,600	
	Power input kW	27.10		29.62		32.06	
	Current input A	45.7-43.4-41.8		50.0-47.5-45.7		54.1-51.4-49.5	
	COP	3.32		3.24		3.15	
Temp. range of cooling	Indoor W.B.	15.0~24.0°C(59~75°F)		15.0~24.0°C(59~75°F)		15.0~24.0°C(59~75°F)	
	Outdoor D.B.	-5.0~46.0°C(23~115°F)		-5.0~46.0°C(23~115°F)		-5.0~46.0°C(23~115°F)	
Heating capacity (Nominal)	*2 kW	100.0		108.0		113.0	
	*2 BTU / h	341,200		368,500		385,600	
	Power input kW	25.70		28.42		30.05	
	Current input A	43.3-41.2-39.7		47.9-45.5-43.9		50.7-48.1-46.4	
	COP	3.89		3.80		3.76	
Temp. range of heating	Indoor W.B.	15.0~27.0°C(59~81°F)		15.0~27.0°C(59~81°F)		15.0~27.0°C(59~81°F)	
	Outdoor W.B.	-20.0~15.5°C(-4~60°F)		-20.0~15.5°C(-4~60°F)		-20.0~15.5°C(-4~60°F)	
Indoor unit connectable	Total capacity	50~130 % of outdoor unit capacity		50~130 % of outdoor unit capacity		50~130 % of outdoor unit capacity	
	Model / Quantity	P15~P250 / 1~50		P15~P250 / 1~50		P15~P250 / 1~50	
Sound pressure level (measured in anechoic room)	dB <A>	64		64.5		65	
Power pressure level (measured in anechoic room)	dB <A>	84		84.5		85	
Refrigerant piping diameter	Liquid pipe mm (in.)	19.05(3/4) Braze		19.05(3/4) Braze		19.05(3/4) Braze	
	Gas pipe mm (in.)	34.93(1-3/8) Braze		41.28(1-5/8) Braze		41.28(1-5/8) Braze	

### Set Model

Model	PUHY-P350YJM-A(-BS)		PUHY-P400YJM-A(-BS)		PUHY-P450YJM-A(-BS)		PUHY-P500YJM-A(-BS)		PUHY-P600YJM-A(-BS)		PUHY-P700YJM-A(-BS)			
FAN	Type x Quantity	Propeller fan x 1		Propeller fan x 2		Propeller fan x 1		Propeller fan x 2		Propeller fan x 2		Propeller fan x 2		
	Air flow rate	m³/min	210		370		210		370		370		370	
		L/s	3,500		6,167		3,500		6,167		6,167		6,167	
		cfm	7,415		13,065		7,415		13,065		13,065		13,065	
	Driving mechanism	Inverter-control, Direct-driven by motor												
Motor output	kW	0.46 x 1		0.46 x 2		0.46 x 1		0.46 x 2		0.46 x 2		0.46 x 2		
	External static press.	0 Pa (0 mmH₂O)		0 Pa (0 mmH₂O)		0 Pa (0 mmH₂O)		0 Pa (0 mmH₂O)		0 Pa (0 mmH₂O)		0 Pa (0 mmH₂O)		
Compressor	Type x Quantity	Inverter scroll hermetic compressor												
	Starting method	Inverter												
	Motor output kW	9.9		11.6		10.1		11.6		11.6		11.6		
Case heater kW	0.045		0.045		0.045		0.045		0.045		0.045			
External finish	Pre-coated galvanized steel sheets (+powder coating for -BS type) <MUNSELL 5Y 8/1 or similar>													
External dimension HxWxD	mm	1,710(1,650 without legs) x 1,220 x 760		1,710(1,650 without legs) x 1,750 x 760		1,710(1,650 without legs) x 1,220 x 760		1,710(1,650 without legs) x 1,750 x 760		1,710(1,650 without legs) x 1,220 x 760		1,710(1,650 without legs) x 1,750 x 760		
	in.	67-3/8(65 without legs) x 48-1/16 x 29-15/16		67-3/8(65 without legs) x 68-15/16 x 29-15/16		67-3/8(65 without legs) x 48-1/16 x 29-15/16		67-3/8(65 without legs) x 68-15/16 x 29-15/16		67-3/8(65 without legs) x 48-1/16 x 29-15/16		67-3/8(65 without legs) x 68-15/16 x 29-15/16		
Protection devices	High pressure protection	High pressure sensor, High pressure switch at 4.15MPa (601 psi)												
	Inverter circuit (COMP./FAN)	Over-heat protection, Over-current protection												
	Compressor	Over-heat protection												
	Fan motor	Thermal switch												
Refrigerant	Type x original charge	R410A x 11.5kg (26lbs)		R410A x 11.8kg (27lbs)		R410A x 11.5kg (26lbs)		R410A x 11.8kg (27lbs)		R410A x 11.8kg (27lbs)		R410A x 11.8kg (27lbs)		
Net weight	kg (lbs)	250(552)		290(640)		250(552)		290(640)		290(640)		290(640)		
Heat exchanger	Salt-resistant cross fin & copper tube													
Pipe between unit and distributor	Liquid pipe mm (in.)	12.7(1/2) Braze		15.88(5/8) Braze		15.88(5/8) Braze		15.88(5/8) Braze		15.88(5/8) Braze		15.88(5/8) Braze		
	Gas pipe mm (in.)	28.58(1-1/8) Braze		28.58(1-1/8) Braze		28.58(1-1/8) Braze		28.58(1-1/8) Braze		28.58(1-1/8) Braze		28.58(1-1/8) Braze		
Optional parts	Outdoor Twinning kit: CMY-Y200VBK2 Joint: CMY-Y102SS/LS-G2, CMY-Y202S/302S-G2 Header: CMY-Y104/108/1010-G													

### Notes:

\*1, \*2 Nominal conditions

	Indoor	Outdoor	Pipe length	Level difference
Cooling	27°C DB/19°C WB (81°F DB/66°F WB)	35°C DB(95°F DB)	7.5m (24-9/16ft.)	0m (0ft.)
Heating	20°C DB(68°F DB)	7°C DB/6°C WB(45°F DB/43°F WB)	7.5m (24-9/16ft.)	0m (0ft.)

\*3 External static pressure option is available (30Pa, 60Pa / 3.1mmH<sub>2</sub>O, 6.1mmH<sub>2</sub>O).

\*Nominal condition \*1, \*2 are subject to JIS B8615-1.

\*Due to continuing improvement, above specification may be subject to change without notice.

Outdoor unit

# OUTDOOR UNIT Y Series PUHY-P YSJM-A(-BS)

## ► Specifications



Model	PUHY-P950YSJM-A(-BS)		PUHY-P1000YSJM-A(-BS)		PUHY-P1050YSJM-A(-BS)		
Power source	3-phase 4-wire 380-400-415V 50/60Hz						
Cooling capacity (Nominal)	*1 kW	108.0		113.0		118.0	
	*1 BTU / h	368,500		385,600		402,600	
	Power input kW	30.50		32.10		33.81	
	Current input A	51.4-48.9-47.1		54.1-51.4-49.6		57.0-54.2-52.2	
	COP	3.54		3.52		3.49	
Temp. range of cooling	Indoor W.B.	15.0~24.0°C(59~75°F)		15.0~24.0°C(59~75°F)		15.0~24.0°C(59~75°F)	
	Outdoor D.B.	-5.0~46.0°C(23~115°F)		-5.0~46.0°C(23~115°F)		-5.0~46.0°C(23~115°F)	
Heating capacity (Nominal)	*2 kW	119.5		127.0		132.0	
	*2 BTU / h	407,700		433,300		450,400	
	Power input kW	30.02		33.15		34.10	
	Current input A	50.6-48.1-46.4		55.9-53.1-51.2		57.5-54.6-52.7	
	COP	3.98		3.83		3.87	
Temp. range of heating	Indoor W.B.	15.0~27.0°C(59~81°F)		15.0~27.0°C(59~81°F)		15.0~27.0°C(59~81°F)	
	Outdoor W.B.	-20.0~15.5°C(-4~60°F)		-20.0~15.5°C(-4~60°F)		-20.0~15.5°C(-4~60°F)	
Indoor unit connectable	Total capacity	50~130 % of outdoor unit capacity		50~130 % of outdoor unit capacity		50~130 % of outdoor unit capacity	
	Model / Quantity	P15~P250 / 1~50		P15~P250 / 2~50		P15~P250 / 2~50	
Sound pressure level (measured in anechoic room)	dB <A>	64.5		64.5		65	
Power pressure level (measured in anechoic room)	dB <A>	84.5		84.5		85	
Refrigerant piping diameter	Liquid pipe mm (in.)	19.05(3/4) Braze		19.05(3/4) Braze		19.05(3/4) Braze	
	Gas pipe mm (in.)	41.28(1-5/8) Braze		41.28(1-5/8) Braze		41.28(1-5/8) Braze	

### Set Model

Model	PUHY-P250YJM-A(-BS)		PUHY-P300YJM-A(-BS)		PUHY-P400YJM-A(-BS)		PUHY-P500YJM-A(-BS)		PUHY-P600YJM-A(-BS)		PUHY-P700YJM-A(-BS)		PUHY-P800YJM-A(-BS)		PUHY-P900YJM-A(-BS)		
FAN	Type x Quantity	Propeller fan x 1		Propeller fan x 1		Propeller fan x 1		Propeller fan x 1		Propeller fan x 1		Propeller fan x 1		Propeller fan x 1			
	Air flow rate	m³/min	170		170		210		170		170		210		210		
		L/s	2,833		2,833		3,500		2,833		2,833		3,500		3,500		
		cfm	6,003		6,003		7,415		6,003		6,003		7,415		7,415		
	Driving mechanism	Inverter-control, Direct-driven by motor															
Motor output	kW	0.46 x 1		0.46 x 1		0.46 x 1		0.46 x 1		0.46 x 1		0.46 x 1		0.46 x 1			
	External static press.	0 Pa (0 mmH <sub>2</sub> O)		0 Pa (0 mmH <sub>2</sub> O)		0 Pa (0 mmH <sub>2</sub> O)		0 Pa (0 mmH <sub>2</sub> O)		0 Pa (0 mmH <sub>2</sub> O)		0 Pa (0 mmH <sub>2</sub> O)		0 Pa (0 mmH <sub>2</sub> O)			
Compressor	Type x Quantity	Inverter scroll hermetic compressor															
	Starting method	Inverter															
	Motor output kW	6.8		7.7		10.1		7.7		7.7		10.1		7.7		10.1	
Case heater kW	0.035		0.045		0.045		0.045		0.045		0.045		0.045		0.045		
External finish	Pre-coated galvanized steel sheets (+powder coating for -BS type) <MUNSELL 5Y 8/1 or similar>																
External dimension HxWxD	mm	1,710(1,650 without legs) x 920 x 760		1,710(1,650 without legs) x 920 x 760		1,710(1,650 without legs) x 1,220 x 760		1,710(1,650 without legs) x 920 x 760		1,710(1,650 without legs) x 920 x 760		1,710(1,650 without legs) x 1,220 x 760		1,710(1,650 without legs) x 920 x 760		1,710(1,650 without legs) x 1,220 x 760	
	in.	67-3/8(65 without legs) x 36-1/4 x 29-15/16		67-3/8(65 without legs) x 36-1/4 x 29-15/16		67-3/8(65 without legs) x 48-1/16 x 29-15/16		67-3/8(65 without legs) x 36-1/4 x 29-15/16		67-3/8(65 without legs) x 36-1/4 x 29-15/16		67-3/8(65 without legs) x 48-1/16 x 29-15/16		67-3/8(65 without legs) x 36-1/4 x 29-15/16		67-3/8(65 without legs) x 48-1/16 x 29-15/16	
Protection devices	High pressure protection	High pressure sensor, High pressure switch at 4.15MPa (601 psi)															
	Inverter circuit (COMP./FAN)	Over-heat protection, Over-current protection															
	Compressor	Over-heat protection															
	Fan motor	Thermal switch															
Refrigerant	Type x original charge	R410A x 8.0kg (18lbs)		R410A x 8.0kg (18lbs)		R410A x 11.5kg (26lbs)		R410A x 8.0kg (18lbs)		R410A x 8.0kg (18lbs)		R410A x 11.5kg (26lbs)		R410A x 8.0kg (18lbs)		R410A x 11.5kg (26lbs)	
Net weight	kg (lbs)	200(441)		215(474)		250(552)		215(474)		215(474)		250(552)		215(474)		250(552)	
Heat exchanger	Salt-resistant cross fin & copper tube																
Pipe between unit and distributor	Liquid pipe mm (in.)	9.52(3/8) Braze		12.7(1/2) Braze		15.88(5/8) Braze		12.7(1/2) Braze		12.7(1/2) Braze		15.88(5/8) Braze		12.7(1/2) Braze		15.88(5/8) Braze	
	Gas pipe mm (in.)	22.2(7/8) Braze		22.2(7/8) Braze		28.58(1-1/8) Braze		22.2(7/8) Braze		22.2(7/8) Braze		28.58(1-1/8) Braze		22.2(7/8) Braze		28.58(1-1/8) Braze	
Optional parts	Outdoor Twinning kit: CMY-Y300VBK2 Joint: CMY-Y102SS/LS-G2, CMY-Y202S/302S-G2 Header: CMY-Y104/108/1010-G																

### Notes:

\*1, \*2 Nominal conditions

	Indoor	Outdoor	Pipe length	Level difference
Cooling	27°C DB/19°C WB (81°F DB/66°F WB)	35°C DB(95°F DB)	7.5m (24-9/16ft.)	0m (0ft.)
Heating	20°C DB(68°F DB)	7°C DB/6°C WB(45°F DB/43°F WB)	7.5m (24-9/16ft.)	0m (0ft.)

\*3 External static pressure option is available (30Pa, 60Pa / 3.1mmH<sub>2</sub>O, 6.1mmH<sub>2</sub>O).

\*Nominal condition \*1, \*2 are subject to JIS B8615-1.

\*Due to continuing improvement, above specification may be subject to change without notice.

Outdoor Unit

# OUTDOOR UNIT Y Series PUHY-P YSJM-A (-BS)

## ► Specifications



Model	PUHY-P1100YSJM-A(-BS)			PUHY-P1150YSJM-A(-BS)			PUHY-P1200YSJM-A(-BS)				
Power source	3-phase 4-wire 380-400-415V 50/60Hz										
Cooling capacity (Nominal)	*1 kW	124.0			130.0			136.0			
	*1 BTU / h	423,100			443,600			464,000			
	Power input kW	35.73			38.34			40.84			
	Current input A	60.3-57.3-55.2			64.7-61.4-59.2			68.9-65.4-63.1			
	COP	3.47			3.39			3.33			
Temp. range of cooling	Indoor W.B.	15.0~24.0°C(59~75°F)			15.0~24.0°C(59~75°F)			15.0~24.0°C(59~75°F)			
	Outdoor D.B.	-5.0~46.0°C(23~115°F)			-5.0~46.0°C(23~115°F)			-5.0~46.0°C(23~115°F)			
Heating capacity (Nominal)	*2 kW	140.0			145.0			150.0			
	*2 BTU / h	477,700			494,700			511,800			
	Power input kW	36.08			37.27			39.26			
	Current input A	60.9-57.8-55.7			62.9-59.7-57.6			66.2-62.9-60.6			
	COP	3.88			3.89			3.82			
Temp. range of heating	Indoor D.B.	15.0~27.0°C(59~81°F)			15.0~27.0°C(59~81°F)			15.0~27.0°C(59~81°F)			
	Outdoor W.B.	-20.0~15.5°C(-4~60°F)			-20.0~15.5°C(-4~60°F)			-20.0~15.5°C(-4~60°F)			
Indoor unit connectable	Total capacity	50~130 % of outdoor unit capacity			50~130 % of outdoor unit capacity			50~130 % of outdoor unit capacity			
Sound pressure level (measured in anechoic room)	Model / Quantity	P15~P250 / 2~50			P15~P250 / 2~50			P15~P250 / 2~50			
Power pressure level (measured in anechoic room)	dB <A>	65			65.5			66			
Refrigerant piping diameter	Liquid pipe mm (in.)	19.05(3/4) Brazed			19.05(3/4) Brazed			19.05(3/4) Brazed			
	Gas pipe mm (in.)	41.28(1-5/8) Brazed			41.28(1-5/8) Brazed			41.28(1-5/8) Brazed			
<b>Set Model</b>											
Model	PUHY-P350YJM-A(-BS)	PUHY-P350YJM-A(-BS)	PUHY-P400YJM-A(-BS)	PUHY-P350YJM-A(-BS)	PUHY-P350YJM-A(-BS)	PUHY-P450YJM-A(-BS)	PUHY-P350YJM-A(-BS)	PUHY-P400YJM-A(-BS)	PUHY-P450YJM-A(-BS)		
FAN	Type x Quantity	Propeller fan x 1	Propeller fan x 1	Propeller fan x 1	Propeller fan x 1	Propeller fan x 1	Propeller fan x 2	Propeller fan x 1	Propeller fan x 1	Propeller fan x 2	
	Air flow rate	m³/min	210	210	210	210	210	370	210	370	
		L/s	3,500	3,500	3,500	3,500	3,500	6,167	3,500	6,167	
		cfm	7,415	7,415	7,415	7,415	7,415	13,065	7,415	13,065	
	Driving mechanism	Inverter-control, Direct-driven by motor									
	Motor output	kW	0.46 x 1	0.46 x 1	0.46 x 1	0.46 x 1	0.46 x 1	0.46 x 2	0.46 x 1	0.46 x 1	0.46 x 2
	*3 External static press.	Pa (0 mmH <sub>2</sub> O)	0 Pa	0 Pa	0 Pa	0 Pa	0 Pa	0 Pa	0 Pa	0 Pa	0 Pa
	Compressor	Type x Quantity	Inverter scroll hermetic compressor								
	Starting method		Inverter								
	Motor output	kW	9.9	9.9	10.1	9.9	9.9	11.6	9.9	10.1	11.6
Case heater	kW	0.045	0.045	0.045	0.045	0.045	0.045	0.045	0.045	0.045	
External finish	Pre-coated galvanized steel sheets (+powder coating for -BS type) <MUNSELL 5Y 8/1 or similar>										
External dimension HxWxD	mm	1,710(1,650 without legs) x 1,220 x 760	1,710(1,650 without legs) x 1,220 x 760	1,710(1,650 without legs) x 1,220 x 760	1,710(1,650 without legs) x 1,220 x 760	1,710(1,650 without legs) x 1,220 x 760	1,710(1,650 without legs) x 1,220 x 760	1,710(1,650 without legs) x 1,220 x 760	1,710(1,650 without legs) x 1,220 x 760	1,710(1,650 without legs) x 1,220 x 760	
	in.	67-3/8(65 without legs) x 48-1/16 x 29-15/16	67-3/8(65 without legs) x 48-1/16 x 29-15/16	67-3/8(65 without legs) x 48-1/16 x 29-15/16	67-3/8(65 without legs) x 48-1/16 x 29-15/16	67-3/8(65 without legs) x 48-1/16 x 29-15/16	67-3/8(65 without legs) x 48-1/16 x 29-15/16	67-3/8(65 without legs) x 48-1/16 x 29-15/16	67-3/8(65 without legs) x 48-1/16 x 29-15/16	67-3/8(65 without legs) x 48-1/16 x 29-15/16	
Protection devices	High pressure protection	High pressure sensor, High pressure switch at 4.15MPa (601 psi)									
	Inverter circuit (COMP./FAN)	Over-heat protection, Over-current protection									
	Compressor	Over-heat protection, Over-current protection									
	Fan motor	Over-heat protection, Over-current protection									
Refrigerant	Type x original charge	R410A x 11.5kg (26lbs)	R410A x 11.5kg (26lbs)	R410A x 11.5kg (26lbs)	R410A x 11.5kg (26lbs)	R410A x 11.5kg (26lbs)	R410A x 11.5kg (26lbs)	R410A x 11.5kg (26lbs)	R410A x 11.5kg (26lbs)	R410A x 11.8kg (27lbs)	
Net weight	kg (lbs)	250(552)	250(552)	250(552)	250(552)	250(552)	290(640)	250(552)	250(552)	290(640)	
Heat exchanger	Salt-resistant cross fin & copper tube										
Pipe between unit and distributor	Liquid pipe mm (in.)	12.7(1/2) Brazed	12.7(1/2) Brazed	15.88(5/8) Brazed	12.7(1/2) Brazed	12.7(1/2) Brazed	15.88(5/8) Brazed	12.7(1/2) Brazed	15.88(5/8) Brazed	15.88(5/8) Brazed	
	Gas pipe mm (in.)	28.58(1-1/8) Brazed	28.58(1-1/8) Brazed	28.58(1-1/8) Brazed	28.58(1-1/8) Brazed	28.58(1-1/8) Brazed	28.58(1-1/8) Brazed	28.58(1-1/8) Brazed	28.58(1-1/8) Brazed	28.58(1-1/8) Brazed	
Optional parts	Outdoor Twinning kit: CMY-Y300VBK2 Joint: CMY-Y102SS/LS-G2, CMY-Y202S/302S-G2 Header: CMY-Y104/108/1010-G										

### Notes:

\*1,\*2 Nominal conditions

	Indoor	Outdoor	Pipe length	Level difference
Cooling	27°C DB/19°C WB (81°F DB/66°F WB)	35°C DB(95°F DB)	7.5m (24-9/16ft.)	0m (0ft.)
Heating	20°C DB(68°F DB)	7°C DB/6°C WB(45°F DB/43°F WB)	7.5m (24-9/16ft.)	0m (0ft.)

\*3 External static pressure option is available (30Pa, 60Pa / 3.1mmH<sub>2</sub>O, 6.1mmH<sub>2</sub>O).

\*Nominal condition \*1,\*2 are subject to JIS B8615-1.

\*Due to continuing improvement, above specification may be subject to change without notice.

# OUTDOOR UNIT Y Series PUHY-P YSJM-A(-BS)

## ► Specifications



Model	PUHY-P1250YSJM-A(-BS)		
Power source	3-phase 4-wire 380-400-415V 50/60Hz		
Cooling capacity (Nominal)	*1 kW	140.0	
	*1 BTU / h	477,700	
	Power input kW	42.94	
	Current input A	72.4-68.8-66.3	
	COP	3.26	
Temp. range of cooling	Indoor W.B.	15.0~24.0°C(59~75°F)	
	Outdoor D.B.	-5.0~46.0°C(23~115°F)	
Heating capacity (Nominal)	*2 kW	156.5	
	*2 BTU / h	534,000	
	Power input kW	40.86	
	Current input A	68.9-65.5-63.1	
	COP	3.83	
Temp. range of heating	Indoor D.B.	15.0~27.0°C(59~81°F)	
	Outdoor W.B.	-20.0~15.5°C(-4~60°F)	
Indoor unit connectable	Total capacity	50~130 % of outdoor unit capacity	
Sound pressure level (measured in anechoic room)	Model / Quantity	P15~P250 / 2~50	
Power pressure level (measured in anechoic room)	dB <A>	66	
Refrigerant piping diameter	Liquid pipe mm (in.)	19.05(3/4) Brazed	
	Gas pipe mm (in.)	41.28(1-5/8) Brazed	
<b>Set Model</b>			
Model	PUHY-P350YJM-A(-BS)		PUHY-P450YJM-A(-BS)
FAN	Type x Quantity	Propeller fan x 1	Propeller fan x 2
	Air flow rate	m³/min	370
		L/s	6,167
		cfm	13,065
	Driving mechanism	Inverter-control, Direct-driven by motor	
	Motor output	kW	0.46 x 2
	*3 External static press.	Pa (0 mmH <sub>2</sub> O)	0 Pa (0 mmH <sub>2</sub> O)
	Compressor	Type x Quantity	Inverter scroll hermetic compressor
	Starting method		Inverter
	Motor output	kW	11.6
Case heater	kW	0.045	
External finish	Pre-coated galvanized steel sheets (+powder coating for -BS type) <MUNSELL 5Y 8/1 or similar>		
External dimension HxWxD	mm	1,710(1,650 without legs) x 1,220 x 760	1,710(1,650 without legs) x 1,750 x 760
	in.	67-3/8(65 without legs) x 48-1/16 x 29-15/16	67-3/8(65 without legs) x 68-15/16 x 29-15/16
Protection devices	High pressure protection	High pressure sensor, High pressure switch at 4.15MPa (601 psi)	
	Inverter circuit (COMP./FAN)	Over-heat protection, Over-current protection	
	Compressor	Over-heat protection, Over-current protection	
	Fan motor	Over-heat protection, Over-current protection	
Refrigerant	Type x original charge	R410A x 11.5kg (26lbs)	R410A x 11.8kg (27lbs)
Net weight	kg (lbs)	250(552)	290(640)
Heat exchanger	Salt-resistant cross fin & copper tube		
Pipe between unit and distributor	Liquid pipe mm (in.)	12.7(1/2) Brazed	15.88(5/8) Brazed
	Gas pipe mm (in.)	28.58(1-1/8) Brazed	28.58(1-1/8) Brazed
Optional parts	Outdoor Twinning kit: CMY-Y300VBK2 Joint: CMY-Y102SS/LS-G2, CMY-Y202S/302S-G2 Header: CMY-Y104/108/1010-G		

### Notes:

\*1,\*2 Nominal conditions

	Indoor	Outdoor	Pipe length	Level difference
Cooling	27°C DB/19°C WB (81°F DB/66°F WB)	35°C DB(95°F DB)	7.5m (24-9/16ft.)	0m (0ft.)
Heating	20°C DB(68°F DB)	7°C DB/6°C WB(45°F DB/43°F WB)	7.5m (24-9/16ft.)	0m (0ft.)

\*3 External static pressure option is available (30Pa, 60Pa / 3.1mmH<sub>2</sub>O, 6.1mmH<sub>2</sub>O).

\*Nominal condition \*1,\*2 are subject to JIS B8615-1.

\*Due to continuing improvement, above specification may be subject to change without notice.

# OUTDOOR UNIT Y Series - High COP PUHY-EP YJM-A(-BS)



## > Specifications

Model	PUHY-EP200YJM-A(-BS)	PUHY-EP250YJM-A(-BS)	PUHY-EP300YJM-A(-BS)
Power source	3-phase 4-wire 380-400-415V 50/60Hz		
Cooling capacity (Nominal)	*1 kW	22.4	33.5
	*1 BTU/h	76,400	114,300
	Power input kW	5.09	8.03
	Current input A	8.5-8.1-7.8	11.3-10.7-10.4
	COP	4.40	4.16
Temp. range of cooling	Indoor W.B.	15.0~24.0°C(59~75°F)	15.0~24.0°C(59~75°F)
	Outdoor D.B.	-5.0~46.0°C(23~115°F)	-5.0~46.0°C(23~115°F)
Heating capacity (Nominal)	*2 kW	25.0	31.5
	*2 BTU/h	85,300	107,500
	Power input kW	5.54	7.15
	Current input A	9.3-8.8-8.5	12.0-11.4-11.0
	COP	4.51	4.40
Temp. range of heating	Indoor W.B.	15.0~27.0°C(59~81°F)	15.0~27.0°C(59~81°F)
	Outdoor W.B.	-20.0~15.5°C(-4~60°F)	-20.0~15.5°C(-4~60°F)
Indoor unit connectable	50~130 % of outdoor unit capacity		
Sound pressure level (measured in anechoic room)	dB <A>		
Power pressure level (measured in anechoic room)	dB <A>		
Refrigerant piping diameter	Liquid pipe mm (in.)	9.52(3/8) Braze	9.52(3/8) Braze (12.7(1/2) Braze, total length >= 90m)
	Gas pipe mm (in.)	19.05(3/4) Braze	22.2(7/8) Braze
FAN	Type x Quantity	Propeller fan x 1	
	Air flow rate	m³/min	
	L/s	2,833	
	cfm	6,003	
	Driving mechanism	Inverter-control, Direct-driven by motor	
	Motor output kW	0.46 x 1	
	*3 External static press.	0 Pa (0 mmH <sub>2</sub> O)	
	Type x Quantity	Inverter scroll hermetic compressor	
	Starting method	Inverter	
	Motor output kW	6.8	
Case heater kW	0.035		
External finish	Pre-coated galvanized steel sheets (+powder coating for -BS type) <MUNSELL 5Y 8/1 or similar>		
	mm	1,710(1,650 without legs) x 920 x 760	1,710(1,650 without legs) x 1,220 x 760
External dimension HxWxD	in.	67-3/8(65 without legs) x 36-1/4 x 29-15/16	67-3/8(65 without legs) x 48-1/16 x 29-15/16
	mm	1,710(1,650 without legs) x 920 x 760	1,710(1,650 without legs) x 1,220 x 760
Protection devices	High pressure protection	High pressure sensor, High pressure switch at 4.15MPa (601 psi)	
	Inverter circuit (COMP./FAN)	Over-heat protection, Over-current protection	
	Compressor	Over-heat protection	
	Fan motor	Thermal switch	
	Refrigerant	R410A x 8.0kg (18lbs)	
Net weight	200(441)		
Heat exchanger	Salt-resistant cross fin & copper tube		
Optional parts	Joint: CMY-Y102SS-G2 Header: CMY-Y104/108/1010-G		

### Notes:

\*1,\*2 Nominal conditions

	Indoor	Outdoor	Pipe length	Level difference
Cooling	27°C DB/19°C WB (81°F DB/66°F WB)	35°C DB(95°F DB)	7.5m (24-9/16ft.)	0m (0ft.)
Heating	20°C DB(68°F DB)	7°C DB/6°C WB(45°F DB/43°F WB)	7.5m (24-9/16ft.)	0m (0ft.)

\*3 External static pressure option is available (30Pa, 60Pa / 3.1mmH<sub>2</sub>O, 6.1mmH<sub>2</sub>O).

\*Nominal condition \*1,\*2 are subject to JIS B8615-1.

\*Due to continuing improvement, above specification may be subject to change without notice.

Outdoor unit

# OUTDOOR UNIT Y Series - High COP PUHY-EP YSJM-A (-BS)



## > Specifications

Model	PUHY-EP400YSJM-A(-BS)	PUHY-EP450YSJM-A(-BS)	PUHY-EP500YSJM-A(-BS)				
Power source	3-phase 4-wire 380-400-415V 50/60Hz						
Cooling capacity (Nominal)	*1 kW	45.0	56.0				
	*1 BTU/h	153,500	191,100				
	Power input kW	10.34	11.87				
	Current input A	17.4-16.5-15.9	20.0-19.0-18.3				
	COP	4.35	4.21				
Temp. range of cooling	Indoor W.B.	15.0~24.0°C(59~75°F)	15.0~24.0°C(59~75°F)				
	Outdoor D.B.	-5.0~46.0°C(23~115°F)	-5.0~46.0°C(23~115°F)				
Heating capacity (Nominal)	*2 kW	50.0	63.0				
	*2 BTU/h	170,600	215,000				
	Power input kW	11.41	12.90				
	Current input A	19.2-18.2-17.6	21.7-20.6-19.9				
	COP	4.38	4.41				
Temp. range of heating	Indoor W.B.	15.0~27.0°C(59~81°F)	15.0~27.0°C(59~81°F)				
	Outdoor W.B.	-20.0~15.5°C(-4~60°F)	-20.0~15.5°C(-4~60°F)				
Indoor unit connectable	50~130 % of outdoor unit capacity						
Sound pressure level (measured in anechoic room)	dB <A>						
Power pressure level (measured in anechoic room)	dB <A>						
Refrigerant piping diameter	Liquid pipe mm (in.)	12.7(1/2) Braze	15.88(5/8) Braze				
	Gas pipe mm (in.)	28.58(1-1/8) Braze	28.58(1-1/8) Braze				
<b>Set Model</b>							
FAN	Type x Quantity	Propeller fan x 1	Propeller fan x 1	Propeller fan x 1	Propeller fan x 1	Propeller fan x 1	Propeller fan x 2
	Air flow rate	m³/min		m³/min		m³/min	
	L/s	170		170		170	
	cfm	2,833		2,833		2,833	
	Driving mechanism	Inverter-control, Direct-driven by motor		Inverter-control, Direct-driven by motor		Inverter-control, Direct-driven by motor	
	Motor output kW	0.46 x 1		0.46 x 1		0.46 x 1	
	*3 External static press.	0 Pa (0 mmH <sub>2</sub> O)		0 Pa (0 mmH <sub>2</sub> O)		0 Pa (0 mmH <sub>2</sub> O)	
	Type x Quantity	Inverter scroll hermetic compressor		Inverter scroll hermetic compressor		Inverter scroll hermetic compressor	
	Starting method	Inverter		Inverter		Inverter	
	Motor output kW	5.4		5.4		5.4	
Case heater kW	0.035		0.035		0.045		
External finish	Pre-coated galvanized steel sheets (+powder coating for -BS type) <MUNSELL 5Y 8/1 or similar>			Pre-coated galvanized steel sheets (+powder coating for -BS type) <MUNSELL 5Y 8/1 or similar>			
	mm	1,710(1,650 without legs) x 920 x 760	1,710(1,650 without legs) x 920 x 760	1,710(1,650 without legs) x 1,220 x 760	1,710(1,650 without legs) x 920 x 760	1,710(1,650 without legs) x 1,750 x 760	
External dimension HxWxD	in.	67-3/8(65 without legs) x 36-1/4 x 29-15/16	67-3/8(65 without legs) x 36-1/4 x 29-15/16	67-3/8(65 without legs) x 48-1/16 x 29-15/16	67-3/8(65 without legs) x 36-1/4 x 29-15/16	67-3/8(65 without legs) x 68-15/16 x 29-15/16	
	mm	1,710(1,650 without legs) x 920 x 760	1,710(1,650 without legs) x 920 x 760	1,710(1,650 without legs) x 1,220 x 760	1,710(1,650 without legs) x 920 x 760	1,710(1,650 without legs) x 1,750 x 760	
Protection devices	High pressure protection	High pressure sensor, High pressure switch at 4.15MPa (601 psi)		High pressure sensor, High pressure switch at 4.15MPa (601 psi)		High pressure sensor, High pressure switch at 4.15MPa (601 psi)	
	Inverter circuit (COMP./FAN)	Over-heat protection, Over-current protection		Over-heat protection, Over-current protection		Over-heat protection, Over-current protection	
	Compressor	Over-heat protection		Over-heat protection		Over-heat protection	
	Fan motor	Thermal switch		Thermal switch		Thermal switch	
	Refrigerant	R410A x 8.0kg (18lbs)		R410A x 8.0kg (18lbs)		R410A x 11.8kg (27lbs)	
Net weight	200(441)		200(441)		290(640)		
Heat exchanger	Salt-resistant cross fin & copper tube		Salt-resistant cross fin & copper tube		Salt-resistant cross fin & copper tube		
Optional parts	Joint: CMY-Y102SS-G2 Header: CMY-Y104/108/1010-G		Joint: CMY-Y102SS-G2 Header: CMY-Y104/108/1010-G		Joint: CMY-Y102SS-G2 Header: CMY-Y104/108/1010-G		

### Notes:

\*1,\*2 Nominal conditions

	Indoor	Outdoor	Pipe length	Level difference
Cooling	27°C DB/19°C WB (81°F DB/66°F WB)	35°C DB(95°F DB)	7.5m (24-9/16ft.)	0m (0ft.)
Heating	20°C DB(68°F DB)	7°C DB/6°C WB(45°F DB/43°F WB)	7.5m (24-9/16ft.)	0m (0ft.)

\*3 External static pressure option is available (30Pa, 60Pa / 3.1mmH<sub>2</sub>O, 6.1mmH<sub>2</sub>O).

\*Nominal condition \*1,\*2 are subject to JIS B8615-1.

\*Due to continuing improvement, above specification may be subject to change without notice.

Outdoor Unit

# OUTDOOR UNIT Y Series - High COP PUHY-EP YSJM-A(1) (-BS)



## > Specifications

Model	PUHY-EP500YSJM-A(-BS)	PUHY-EP550YSJM-A(-BS)	PUHY-EP600YSJM-A(-BS)
Power source	3-phase 4-wire 380-400-415V 50/60Hz		
Cooling capacity (Nominal)	*1 kW	56.0	63.0
	*1 BTU / h	191,100	215,000
	Power input kW	13.65	15.36
	Current input A	23.0-21.8-21.0	25.9-24.6-23.7
COP	kW / kW	4.10	4.10
	Indoor W.B.	15.0~24.0°C(59~75°F)	15.0~24.0°C(59~75°F)
	Outdoor D.B.	-5.0~46.0°C(23~115°F)	-5.0~46.0°C(23~115°F)
Heating capacity (Nominal)	*2 kW	63.0	69.0
	*2 BTU / h	215,000	235,400
	Power input kW	14.54	15.78
	Current input A	24.5-23.3-22.4	26.6-25.3-24.3
COP	kW / kW	4.33	4.37
	Indoor W.B.	15.0~27.0°C(59~81°F)	15.0~27.0°C(59~81°F)
	Outdoor W.B.	-20.0~15.5°C(-4~60°F)	-20.0~15.5°C(-4~60°F)
Temp. range of heating	Indoor W.B.	15.0~27.0°C(59~81°F)	15.0~27.0°C(59~81°F)
	Outdoor W.B.	-20.0~15.5°C(-4~60°F)	-20.0~15.5°C(-4~60°F)
Indoor unit connectable	Total capacity	50~130 % of outdoor unit capacity	50~130 % of outdoor unit capacity
	Model / Quantity	P15~P250 / 1~43	P15~P250 / 1~47
Sound pressure level (measured in anechoic room)	dB <A>	63	63.5
	Power pressure level (measured in anechoic room)	dB <A>	83
Refrigerant piping diameter	Liquid pipe mm (in.)	15.88(5/8) Braze	15.88(5/8) Braze
	Gas pipe mm (in.)	28.58(1-1/8) Braze	28.58(1-1/8) Braze

Set Model	PUHY-EP250YJM-A(-BS)	PUHY-EP250YJM-A(-BS)	PUHY-EP250YJM-A(-BS)	PUHY-EP300YJM-A(-BS)	PUHY-EP300YJM-A(-BS)	PUHY-EP300YJM-A(-BS)		
FAN	Type x Quantity	Propeller fan x 1		Propeller fan x 1		Propeller fan x 2		
	Air flow rate	m <sup>3</sup> /min	210	210	210	370	370	
		L/s	3,500	3,500	3,500	6,167	6,167	
		cfm	7,415	7,415	7,415	13,065	13,065	
	Driving mechanism	Inverter-control, Direct-driven by motor		Inverter-control, Direct-driven by motor		Inverter-control, Direct-driven by motor		
	Motor output kW	0.46 x 1		0.46 x 1		0.46 x 2		
	*3 External static press.	0 Pa (0 mmH <sub>2</sub> O)		0 Pa (0 mmH <sub>2</sub> O)		0 Pa (0 mmH <sub>2</sub> O)		
	Compressor	Type x Quantity	Inverter scroll hermetic compressor		Inverter scroll hermetic compressor		Inverter scroll hermetic compressor	
		Starting method	Inverter		Inverter		Inverter	
		Motor output kW	6.8		6.8		7.7	
Case heater kW		0.045		0.045		0.045		
External finish	Pre-coated galvanized steel sheets (+powder coating for -BS type) <MUNSELL 5Y 8/1 or similar>		Pre-coated galvanized steel sheets (+powder coating for -BS type) <MUNSELL 5Y 8/1 or similar>		Pre-coated galvanized steel sheets (+powder coating for -BS type) <MUNSELL 5Y 8/1 or similar>			
	External dimension HxWxD	1,710(1,650 without legs) x 1,220 x 760		1,710(1,650 without legs) x 1,220 x 760		1,710(1,650 without legs) x 1,750 x 760		
Protection devices	High pressure protection	High pressure sensor, High pressure switch at 4.15MPa (601 psi)		High pressure sensor, High pressure switch at 4.15MPa (601 psi)		High pressure sensor, High pressure switch at 4.15MPa (601 psi)		
	Inverter circuit (COMP/FAN)	Over-heat protection, Over-current protection		Over-heat protection, Over-current protection		Over-heat protection, Over-current protection		
	Compressor	Over-heat protection		Over-heat protection		Over-heat protection		
	Fan motor	Thermal switch		Thermal switch		Thermal switch		
Refrigerant	Type x original charge	R410A x 11.5kg (26lbs)	R410A x 11.5kg (26lbs)	R410A x 11.5kg (26lbs)	R410A x 11.8kg (27lbs)	R410A x 11.8kg (27lbs)		
Net weight	kg (lbs)	250(552)		250(552)		290(640)		
Heat exchanger	Salt-resistant cross fin & copper tube		Salt-resistant cross fin & copper tube		Salt-resistant cross fin & copper tube			
	Pipe between unit and distributor	Liquid pipe mm (in.)	9.52(3/8) Braze		12.7(1/2) Braze			
Optional parts	Outdoor Twinning kit: CMY-Y100VBK2		Outdoor Twinning kit: CMY-Y100VBK2		Outdoor Twinning kit: CMY-Y100VBK2			
	Joint: CMY-Y102SS/LS-G2, CMY-Y202S-G2		Joint: CMY-Y102SS/LS-G2, CMY-Y202S-G2		Joint: CMY-Y102SS/LS-G2, CMY-Y202S-G2			
Header: CMY-Y104/108/1010-G		Header: CMY-Y104/108/1010-G		Header: CMY-Y104/108/1010-G				

### Notes:

\*1,\*2 Nominal conditions

	Indoor	Outdoor	Pipe length	Level difference
Cooling	27°C DB/19°C WB (81°F DB/66°F WB)	35°C DB(95°F DB)	7.5m (24-9/16ft.)	0m (0ft.)
Heating	20°C DB(68°F DB)	7°C DB/6°C WB(45°F DB/43°F WB)	7.5m (24-9/16ft.)	0m (0ft.)

\*3 External static pressure option is available (30Pa, 60Pa / 3.1mmH<sub>2</sub>O, 6.1mmH<sub>2</sub>O).

\*Nominal condition \*1,\*2 are subject to JIS B8615-1.

\*Due to continuing improvement, above specification may be subject to change without notice.

# OUTDOOR UNIT Y Series - High COP PUHY-EP YSJM-A (-BS)



## > Specifications

Model	PUHY-EP650YSJM-A(-BS)	PUHY-EP700YSJM-A(-BS)
Power source	3-phase 4-wire 380-400-415V 50/60Hz	
Cooling capacity (Nominal)	*1 kW	73.0
	*1 BTU / h	249,100
	Power input kW	17.46
	Current input A	29.4-28.0-26.9
COP	kW / kW	4.18
	Indoor W.B.	15.0~24.0°C(59~75°F)
	Outdoor D.B.	-5.0~46.0°C(23~115°F)
Heating capacity (Nominal)	*2 kW	81.5
	*2 BTU / h	278,100
	Power input kW	18.56
	Current input A	31.3-29.7-28.6
COP	kW / kW	4.39
	Indoor W.B.	15.0~27.0°C(59~81°F)
	Outdoor W.B.	-20.0~15.5°C(-4~60°F)
Temp. range of heating	Indoor W.B.	15.0~27.0°C(59~81°F)
	Outdoor W.B.	-20.0~15.5°C(-4~60°F)
Indoor unit connectable	Total capacity	50~130 % of outdoor unit capacity
	Model / Quantity	P15~P250 / 1~50
Sound pressure level (measured in anechoic room)	dB <A>	63
	Power pressure level (measured in anechoic room)	dB <A>
Refrigerant piping diameter	Liquid pipe mm (in.)	15.88 (5/8) Braze
	Gas pipe mm (in.)	28.58 (1-1/8) Braze

Set Model	PUHY-EP200YJM-A(-BS)	PUHY-EP200YJM-A(-BS)	PUHY-EP250YJM-A(-BS)	PUHY-EP200YJM-A(-BS)	PUHY-EP200YJM-A(-BS)	PUHY-EP300YJM-A(-BS)		
FAN	Type x Quantity	Propeller fan x 1		Propeller fan x 1		Propeller fan x 2		
	Air flow rate	m <sup>3</sup> /min	170	170	210	170	370	
		L/s	2,833	2,833	3,500	2,833	6,167	
		cfm	6,003	6,003	7,415	6,003	13,065	
	Driving mechanism	Inverter-control, Direct-driven by motor		Inverter-control, Direct-driven by motor		Inverter-control, Direct-driven by motor		
	Motor output kW	0.46 x 1		0.46 x 1		0.46 x 2		
	*3 External static press.	0 Pa (0 mmH <sub>2</sub> O)		0 Pa (0 mmH <sub>2</sub> O)		0 Pa (0 mmH <sub>2</sub> O)		
	Compressor	Type x Quantity	Inverter scroll hermetic compressor		Inverter scroll hermetic compressor		Inverter scroll hermetic compressor	
		Starting method	Inverter		Inverter		Inverter	
		Motor output kW	5.4		6.8		7.7	
Case heater kW		0.035		0.045		0.045		
External finish	Pre-coated galvanized steel sheets (+powder coating for -BS type) <MUNSELL 5Y 8/1 or similar>		Pre-coated galvanized steel sheets (+powder coating for -BS type) <MUNSELL 5Y 8/1 or similar>		Pre-coated galvanized steel sheets (+powder coating for -BS type) <MUNSELL 5Y 8/1 or similar>			
	External dimension HxWxD	1,710(1,650 without legs) x 920 x 760		1,710(1,650 without legs) x 920 x 760		1,710(1,650 without legs) x 1,750 x 760		
Protection devices	High pressure protection	High pressure sensor, High pressure switch at 4.15MPa (601 psi)		High pressure sensor, High pressure switch at 4.15MPa (601 psi)		High pressure sensor, High pressure switch at 4.15MPa (601 psi)		
	Inverter circuit (COMP/FAN)	Over-heat protection, Over-current protection		Over-heat protection, Over-current protection		Over-heat protection, Over-current protection		
	Compressor	Over-heat protection		Over-heat protection		Over-heat protection		
	Fan motor	Thermal switch		Thermal switch		Thermal switch		
Refrigerant	Type x original charge	R410A x 8.0kg (18lbs)	R410A x 8.0kg (18lbs)	R410A x 11.5kg (26lbs)	R410A x 8.0kg (18lbs)	R410A x 11.8kg (27lbs)		
Net weight	kg (lbs)	200(441)		250(552)		290(640)		
Heat exchanger	Salt-resistant cross fin & copper tube		Salt-resistant cross fin & copper tube		Salt-resistant cross fin & copper tube			
	Pipe between unit and distributor	Liquid pipe mm (in.)	9.52(3/8) Braze		12.7(1/2) Braze			
Optional parts	Outdoor Twinning kit: CMY-Y300VBK2		Outdoor Twinning kit: CMY-Y300VBK2		Outdoor Twinning kit: CMY-Y300VBK2			
	Joint: CMY-Y102SS/LS-G2, CMY-Y202S/302S-G2		Joint: CMY-Y102SS/LS-G2, CMY-Y202S/302S-G2		Joint: CMY-Y102SS/LS-G2, CMY-Y202S/302S-G2			
Header: CMY-Y104/108/1010-G		Header: CMY-Y104/108/1010-G		Header: CMY-Y104/108/1010-G				

### Notes:

\*1,\*2 Nominal conditions

	Indoor	Outdoor	Pipe length	Level difference
Cooling	27°C DB/19°C WB (81°F DB/66°F WB)	35°C DB(95°F DB)	7.5m (24-9/16ft.)	0m (0ft.)
Heating	20°C DB(68°F DB)	7°C DB/6°C WB(45°F DB/43°F WB)	7.5m (24-9/16ft.)	0m (0ft.)

\*3 External static pressure option is available (30Pa, 60Pa / 3.1mmH<sub>2</sub>O, 6.1mmH<sub>2</sub>O).

\*Nominal condition \*1,\*2 are subject to JIS B8615-1.

\*Due to continuing improvement, above specification may be subject to change without notice.

# OUTDOOR UNIT Y Series - High COP PUHY-EP YSJM-A(1) (-BS)



## > Specifications

Model		PUHY-EP700YSJM-A1(-BS)			PUHY-EP750YSJM-A(-BS)				
Power source		3-phase 4-wire 380-400-415V 50/60Hz			3-phase 4-wire 380-400-415V 50/60Hz				
Cooling capacity (Nominal)		80.0			85.0				
Power input		273.000			290.000				
Current input		19.41			20.43				
COP		32.7-31.1-30.0			34.4-32.7-31.5				
Temp. range of cooling		Indoor W.B. 15.0~24.0°C(59~75°F) Outdoor D.B. -5.0~46.0°C(23~115°F)			Indoor W.B. 15.0~24.0°C(59~75°F) Outdoor D.B. -5.0~46.0°C(23~115°F)				
Heating capacity (Nominal)		88.0			95.0				
Power input		300.300			324.100				
Current input		20.32			21.93				
COP		34.3-32.5-31.4			37.0-35.1-33.8				
Temp. range of heating		Indoor W.B. 15.0~27.0°C(59~81°F) Outdoor W.B. -20.0~15.5°C(-4~60°F)			Indoor W.B. 15.0~27.0°C(59~81°F) Outdoor W.B. -20.0~15.5°C(-4~60°F)				
Indoor unit connectable		Total capacity 50~130 % of outdoor unit capacity Model / Quantity P15~P250 / 1~50			Total capacity 50~130 % of outdoor unit capacity Model / Quantity P15~P250 / 1~50				
Sound pressure level (measured in anechoic room)		64			64.5				
Power pressure level (measured in anechoic room)		84			84.5				
Refrigerant piping diameter		Liquid pipe 19.05(3/4) Brazed Gas pipe 34.93(1-3/8) Brazed			Liquid pipe 19.05(3/4) Brazed Gas pipe 34.93(1-3/8) Brazed				
<b>Set Model</b>									
Model		PUHY-EP200YJM-A(-BS)	PUHY-EP250YJM-A(-BS)	PUHY-EP250YJM-A(-BS)	PUHY-EP200YJM-A(-BS)	PUHY-EP250YJM-A(-BS)	PUHY-EP300YJM-A(-BS)		
FAN		Propeller fan x 1			Propeller fan x 1			Propeller fan x 2	
Air flow rate		170			210			370	
L/s		2,833			3,500			6,167	
cfm		6,003			7,415			13,065	
Driving mechanism		Inverter-control, Direct-driven by motor			Inverter-control, Direct-driven by motor			Inverter-control, Direct-driven by motor	
Motor output		0.46 x 1			0.46 x 1			0.46 x 2	
External static press.		0 Pa (0 mmH <sub>2</sub> O)			0 Pa (0 mmH <sub>2</sub> O)			0 Pa (0 mmH <sub>2</sub> O)	
Compressor		Inverter scroll hermetic compressor			Inverter scroll hermetic compressor			Inverter scroll hermetic compressor	
Starting method		Inverter			Inverter			Inverter	
Motor output		6.8			6.8			7.7	
Case heater		0.035			0.045			0.045	
External finish		Pre-coated galvanized steel sheets (+powder coating for -BS type) <MUNSELL 5Y 8/1 or similar>			Pre-coated galvanized steel sheets (+powder coating for -BS type) <MUNSELL 5Y 8/1 or similar>			Pre-coated galvanized steel sheets (+powder coating for -BS type) <MUNSELL 5Y 8/1 or similar>	
External dimension HxWxD		1,710(1,650 without legs) x 920 x 760			1,710(1,650 without legs) x 1,220 x 760			1,710(1,650 without legs) x 1,750 x 760	
in.		67-3/8(65 without legs) x 36-1/4 x 29-15/16			67-3/8(65 without legs) x 48-1/16 x 29-15/16			67-3/8(65 without legs) x 68-15/16 x 29-15/16	
Protection devices		High pressure protection, High pressure sensor, High pressure switch at 4.15MPa (601 psi)			High pressure protection, High pressure sensor, High pressure switch at 4.15MPa (601 psi)			High pressure protection, High pressure sensor, High pressure switch at 4.15MPa (601 psi)	
Compressor		Over-heat protection, Over-current protection			Over-heat protection, Over-current protection			Over-heat protection, Over-current protection	
Fan motor		Thermal switch			Thermal switch			Thermal switch	
Refrigerant		R410A x 8.0kg (18lbs)			R410A x 11.5kg (26lbs)			R410A x 11.8kg (27lbs)	
Net weight		200(441)			250(552)			290(640)	
Heat exchanger		Salt-resistant cross fin & copper tube			Salt-resistant cross fin & copper tube			Salt-resistant cross fin & copper tube	
Pipe between unit		9.52(3/8) Brazed			9.52(3/8) Brazed			12.7(1/2) Brazed	
and distributor		19.05(3/4) Brazed			22.2(7/8) Brazed			22.2(7/8) Brazed	
Optional parts		Outdoor Twinning kit: CMY-Y300VBK2 Joint: CMY-Y102SS/LS-G2, CMY-Y202S/302S-G2 Header: CMY-Y104/108/1010-G			Outdoor Twinning kit: CMY-Y300VBK2 Joint: CMY-Y102SS/LS-G2, CMY-Y202S/302S-G2 Header: CMY-Y104/108/1010-G			Outdoor Twinning kit: CMY-Y300VBK2 Joint: CMY-Y102SS/LS-G2, CMY-Y202S/302S-G2 Header: CMY-Y104/108/1010-G	

### Notes:

\*1,\*2 Nominal conditions

	Indoor	Outdoor	Pipe length	Level difference
Cooling	27°C DB/19°C WB (81°F DB/66°F WB)	35°C DB(95°F DB)	7.5m (24-9/16ft.)	0m (0ft.)
Heating	20°C DB(68°F DB)	7°C DB/6°C WB(45°F DB/43°F WB)	7.5m (24-9/16ft.)	0m (0ft.)

\*3 External static pressure option is available (30Pa, 60Pa / 3.1mmH<sub>2</sub>O, 6.1mmH<sub>2</sub>O).

\*Nominal condition \*1,\*2 are subject to JIS B8615-1.

\*Due to continuing improvement, above specification may be subject to change without notice.

# OUTDOOR UNIT Y Series - High COP PUHY-EP YSJM-A(1) (-BS)



## > Specifications

Model		PUHY-EP750YSJM-A1(-BS)			PUHY-EP800YSJM-A(-BS)				
Power source		3-phase 4-wire 380-400-415V 50/60Hz			3-phase 4-wire 380-400-415V 50/60Hz				
Cooling capacity (Nominal)		85.0			90.0				
Power input		290.000			307.100				
Current input		20.93			21.63				
COP		35.3-33.5-32.3			36.5-34.6-33.4				
Temp. range of cooling		Indoor W.B. 15.0~24.0°C(59~75°F) Outdoor D.B. -5.0~46.0°C(23~115°F)			Indoor W.B. 15.0~24.0°C(59~75°F) Outdoor D.B. -5.0~46.0°C(23~115°F)				
Heating capacity (Nominal)		95.0			100.0				
Power input		324.100			341.200				
Current input		21.78			22.77				
COP		36.7-34.9-33.6			38.4-36.5-35.1				
Temp. range of heating		Indoor W.B. 15.0~27.0°C(59~81°F) Outdoor W.B. -20.0~15.5°C(-4~60°F)			Indoor W.B. 15.0~27.0°C(59~81°F) Outdoor W.B. -20.0~15.5°C(-4~60°F)				
Indoor unit connectable		Total capacity 50~130 % of outdoor unit capacity Model / Quantity P15~P250 / 1~50			Total capacity 50~130 % of outdoor unit capacity Model / Quantity P15~P250 / 1~50				
Sound pressure level (measured in anechoic room)		65			65				
Power pressure level (measured in anechoic room)		85			85				
Refrigerant piping diameter		Liquid pipe 19.05(3/4) Brazed Gas pipe 34.93(1-3/8) Brazed			Liquid pipe 19.05(3/4) Brazed Gas pipe 34.93(1-3/8) Brazed				
<b>Set Model</b>									
Model		PUHY-EP250YJM-A(-BS)	PUHY-EP250YJM-A(-BS)	PUHY-EP250YJM-A(-BS)	PUHY-EP200YJM-A(-BS)	PUHY-EP300YJM-A(-BS)	PUHY-EP300YJM-A(-BS)		
FAN		Propeller fan x 1			Propeller fan x 1			Propeller fan x 2	
Air flow rate		210			210			370	
L/s		3,500			3,500			6,167	
cfm		7,415			7,415			13,065	
Driving mechanism		Inverter-control, Direct-driven by motor			Inverter-control, Direct-driven by motor			Inverter-control, Direct-driven by motor	
Motor output		0.46 x 1			0.46 x 1			0.46 x 2	
External static press.		0 Pa (0 mmH <sub>2</sub> O)			0 Pa (0 mmH <sub>2</sub> O)			0 Pa (0 mmH <sub>2</sub> O)	
Compressor		Inverter scroll hermetic compressor			Inverter scroll hermetic compressor			Inverter scroll hermetic compressor	
Starting method		Inverter			Inverter			Inverter	
Motor output		6.8			6.8			7.7	
Case heater		0.045			0.045			0.045	
External finish		Pre-coated galvanized steel sheets (+powder coating for -BS type) <MUNSELL 5Y 8/1 or similar>			Pre-coated galvanized steel sheets (+powder coating for -BS type) <MUNSELL 5Y 8/1 or similar>			Pre-coated galvanized steel sheets (+powder coating for -BS type) <MUNSELL 5Y 8/1 or similar>	
External dimension HxWxD		1,710(1,650 without legs) x 1,220 x 760			1,710(1,650 without legs) x 1,220 x 760			1,710(1,650 without legs) x 1,750 x 760	
in.		67-3/8(65 without legs) x 48-1/16 x 29-15/16			67-3/8(65 without legs) x 48-1/16 x 29-15/16			67-3/8(65 without legs) x 68-15/16 x 29-15/16	
Protection devices		High pressure protection, High pressure sensor, High pressure switch at 4.15MPa (601 psi)			High pressure protection, High pressure sensor, High pressure switch at 4.15MPa (601 psi)			High pressure protection, High pressure sensor, High pressure switch at 4.15MPa (601 psi)	
Compressor		Over-heat protection, Over-current protection			Over-heat protection, Over-current protection			Over-heat protection, Over-current protection	
Fan motor		Thermal switch			Thermal switch			Thermal switch	
Refrigerant		R410A x 11.5kg (26lbs)			R410A x 11.5kg (26lbs)			R410A x 11.8kg (27lbs)	
Net weight		250(552)			250(552)			290(640)	
Heat exchanger		Salt-resistant cross fin & copper tube			Salt-resistant cross fin & copper tube			Salt-resistant cross fin & copper tube	
Pipe between unit		9.52(3/8) Brazed			9.52(3/8) Brazed			12.7(1/2) Brazed	
and distributor		22.2(7/8) Brazed			22.2(7/8) Brazed			22.2(7/8) Brazed	
Optional parts		Outdoor Twinning kit: CMY-Y300VBK2 Joint: CMY-Y102SS/LS-G2, CMY-Y202S/302S-G2 Header: CMY-Y104/108/1010-G			Outdoor Twinning kit: CMY-Y300VBK2 Joint: CMY-Y102SS/LS-G2, CMY-Y202S/302S-G2 Header: CMY-Y104/108/1010-G			Outdoor Twinning kit: CMY-Y300VBK2 Joint: CMY-Y102SS/LS-G2, CMY-Y202S/302S-G2 Header: CMY-Y104/108/1010-G	

### Notes:

\*1,\*2 Nominal conditions

	Indoor	Outdoor	Pipe length	Level difference
Cooling	27°C DB/19°C WB (81°F DB/66°F WB)	35°C DB(95°F DB)	7.5m (24-9/16ft.)	0m (0ft.)
Heating	20°C DB(68°F DB)	7°C DB/6°C WB(45°F DB/43°F WB)	7.5m (24-9/16ft.)	0m (0ft.)

\*3 External static pressure option is available (30Pa, 60Pa / 3.1mmH<sub>2</sub>O, 6.1mmH<sub>2</sub>O).

\*Nominal condition \*1,\*2 are subject to JIS B8615-1.

\*Due to continuing improvement, above specification may be subject to change without notice.

# OUTDOOR UNIT Y Series - High COP PUHY-EP YSJM-A(1) (-BS)



## ► Specifications

Model		PUHY-EP800YSJM-A(-BS)			PUHY-EP850YSJM-A(-BS)			
Power source		3-phase 4-wire 380-400-415V 50/60Hz			3-phase 4-wire 380-400-415V 50/60Hz			
Cooling capacity (Nominal)	*1 kW	90.0			96.0			
	*1 BTU / h	307,100			327,600			
	Power input kW	22.16			23.58			
	Current input A	37.4-35.5-34.2			39.8-37.8-36.4			
COP	kW / kW	4.06			4.07			
	W.B.	15.0~24.0°C(59~75°F)			15.0~24.0°C(59~75°F)			
Temp. range of cooling	Indoor W.B.	15.0~24.0°C(59~75°F)			15.0~24.0°C(59~75°F)			
	Outdoor D.B.	-5.0~46.0°C(23~115°F)			-5.0~46.0°C(23~115°F)			
Heating capacity (Nominal)	*2 kW	100.0			108.0			
	*2 BTU / h	341,200			368,500			
	Power input kW	22.98			24.65			
	Current input A	38.7-36.8-35.5			41.6-39.5-38.1			
COP	kW / kW	4.35			4.38			
	W.B.	15.0~27.0°C(59~81°F)			15.0~27.0°C(59~81°F)			
Temp. range of heating	Indoor W.B.	15.0~27.0°C(59~81°F)			15.0~27.0°C(59~81°F)			
	Outdoor W.B.	-20.0~15.5°C(-4~60°F)			-20.0~15.5°C(-4~60°F)			
Indoor unit connectable	Total capacity	50~130 % of outdoor unit capacity			50~130 % of outdoor unit capacity			
	Model / Quantity	P15~P250 / 1~50			P15~P250 / 1~50			
Sound pressure level (measured in anechoic room)	dB <A>	65			65.5			
Power pressure level (measured in anechoic room)	dB <A>	85			85.5			
Refrigerant piping diameter	Liquid pipe mm (in.)	19.05(3/4) Brazed			19.05(3/4) Brazed			
	Gas pipe mm (in.)	34.93(1-3/8) Brazed			41.28(1-5/8) Brazed			
<b>Set Model</b>								
Model		PUHY-EP250YJM-A(-BS)	PUHY-EP250YJM-A(-BS)	PUHY-EP300YJM-A(-BS)	PUHY-EP250YJM-A(-BS)	PUHY-EP300YJM-A(-BS)	PUHY-EP300YJM-A(-BS)	
FAN	Type x Quantity	Propeller fan x 1		Propeller fan x 2	Propeller fan x 1		Propeller fan x 2	
	Air flow rate	m³/min	210		370	210		370
		L/s	3,500		6,167	3,500		6,167
		cfm	7,415		13,065	7,415		13,065
	Driving mechanism	Inverter-control, Direct-driven by motor		Inverter-control, Direct-driven by motor	Inverter-control, Direct-driven by motor		Inverter-control, Direct-driven by motor	
	Motor output	kW	0.46 x 1		0.46 x 2	0.46 x 1		0.46 x 2
*3 External static press.		0 Pa (0 mmH₂O)		0 Pa (0 mmH₂O)	0 Pa (0 mmH₂O)		0 Pa (0 mmH₂O)	
Compressor	Type x Quantity	Inverter scroll hermetic compressor		Inverter scroll hermetic compressor	Inverter scroll hermetic compressor		Inverter scroll hermetic compressor	
	Starting method	Inverter		Inverter	Inverter		Inverter	
	Motor output kW	6.8		7.7	6.8		7.7	
	Case heater kW	0.045		0.045	0.045		0.045	
External finish		Pre-coated galvanized steel sheets (+powder coating for -BS type) <MUNSELL 5Y 8/1 or similar>			Pre-coated galvanized steel sheets (+powder coating for -BS type) <MUNSELL 5Y 8/1 or similar>			
External dimension HxWxD	mm	1,710(1,650 without legs) x 1,220 x 760	1,710(1,650 without legs) x 1,220 x 760	1,710(1,650 without legs) x 1,750 x 760	1,710(1,650 without legs) x 1,220 x 760	1,710(1,650 without legs) x 1,750 x 760	1,710(1,650 without legs) x 1,750 x 760	
	in.	67-3/8(65 without legs) x 48-1/16 x 29-15/16	67-3/8(65 without legs) x 48-1/16 x 29-15/16	67-3/8(65 without legs) x 68-15/16 x 29-15/16	67-3/8(65 without legs) x 48-1/16 x 29-15/16	67-3/8(65 without legs) x 68-15/16 x 29-15/16	67-3/8(65 without legs) x 68-15/16 x 29-15/16	
Protection devices	High pressure protection	High pressure sensor, High pressure switch at 4.15MPa (601 psi)			High pressure sensor, High pressure switch at 4.15MPa (601 psi)			
	Inverter circuit (COMP/FAN)	Over-heat protection, Over-current protection			Over-heat protection, Over-current protection			
	Compressor	Over-heat protection			Over-heat protection			
	Fan motor	Thermal switch			Thermal switch			
Refrigerant	Type x original charge	R410A x 11.5kg (26lbs)	R410A x 11.5kg (26lbs)	R410A x 11.8kg (27lbs)	R410A x 11.5kg (26lbs)	R410A x 11.8kg (27lbs)	R410A x 11.8kg (27lbs)	
	Net weight kg (lbs)	250(552)	250(552)	290(640)	250(552)	290(640)	290(640)	
Heat exchanger		Salt-resistant cross fin & copper tube			Salt-resistant cross fin & copper tube			
Pipe between unit and distributor	Liquid pipe mm (in.)	9.52(3/8) Brazed	9.52(3/8) Brazed	12.7(1/2) Brazed	9.52(3/8) Brazed	12.7(1/2) Brazed	12.7(1/2) Brazed	
	Gas pipe mm (in.)	22.2(7/8) Brazed	22.2(7/8) Brazed	22.2(7/8) Brazed	22.2(7/8) Brazed	22.2(7/8) Brazed	22.2(7/8) Brazed	
Optional parts		Outdoor Twinning kit: CMY-Y300VBK2 Joint: CMY-Y102SS/LS-G2, CMY-Y202S/302S-G2 Header: CMY-Y104/108/1010-G			Outdoor Twinning kit: CMY-Y300VBK2 Joint: CMY-Y102SS/LS-G2, CMY-Y202S/302S-G2 Header: CMY-Y104/108/1010-G			

### Notes:

\*1,\*2 Nominal conditions

	Indoor	Outdoor	Pipe length	Level difference
Cooling	27°C DB/19°C WB (81°F DB/66°F WB)	35°C DB(95°F DB)	7.5m (24-9/16ft.)	0m (0ft.)
Heating	20°C DB(68°F DB)	7°C DB/6°C WB(45°F DB/43°F WB)	7.5m (24-9/16ft.)	0m (0ft.)

\*3 External static pressure option is available (30Pa, 60Pa / 3.1mmH<sub>2</sub>O, 6.1mmH<sub>2</sub>O).

\*Nominal condition \*1,\*2 are subject to JIS B8615-1.

\*Due to continuing improvement, above specification may be subject to change without notice.

# OUTDOOR UNIT Y Series - High COP PUHY-EP YSJM-A(-BS)



## ► Specifications

Model		PUHY-EP900YSJM-A(-BS)			
Power source		3-phase 4-wire 380-400-415V 50/60Hz			
Cooling capacity (Nominal)	*1 kW	101.0			
	*1 BTU / h	344,600			
	Power input kW	24.81			
	Current input A	41.8-39.7-38.3			
COP	kW / kW	4.07			
	W.B.	15.0~24.0°C(59~75°F)			
Temp. range of cooling	Indoor W.B.	15.0~24.0°C(59~75°F)			
	Outdoor D.B.	-5.0~46.0°C(23~115°F)			
Heating capacity (Nominal)	*2 kW	113.0			
	*2 BTU / h	385,600			
	Power input kW	25.50			
	Current input A	43.0-40.8-39.4			
COP	kW / kW	4.43			
	W.B.	15.0~27.0°C(59~81°F)			
Temp. range of heating	Indoor W.B.	15.0~27.0°C(59~81°F)			
	Outdoor W.B.	-20.0~15.5°C(-4~60°F)			
Indoor unit connectable	Total capacity	50~130 % of outdoor unit capacity			
	Model / Quantity	P15~P250 / 1~50			
Sound pressure level (measured in anechoic room)	dB <A>	66			
Power pressure level (measured in anechoic room)	dB <A>	86			
Refrigerant piping diameter	Liquid pipe mm (in.)	19.05(3/4) Brazed			
	Gas pipe mm (in.)	41.28(1-5/8) Brazed			
<b>Set Model</b>					
Model		PUHY-EP300YJM-A(-BS)	PUHY-EP300YJM-A(-BS)	PUHY-EP300YJM-A(-BS)	
FAN	Type x Quantity	Propeller fan x 2		Propeller fan x 2	
	Air flow rate	m³/min	370		370
		L/s	6,167		6,167
		cfm	13,065		13,065
	Driving mechanism	Inverter-control, Direct-driven by motor		Inverter-control, Direct-driven by motor	
	Motor output	kW	0.46 x 2		0.46 x 2
*3 External static press.		0 Pa (0 mmH₂O)		0 Pa (0 mmH₂O)	
Compressor	Type x Quantity	Inverter scroll hermetic compressor		Inverter scroll hermetic compressor	
	Starting method	Inverter		Inverter	
	Motor output kW	7.7		7.7	
	Case heater kW	0.045		0.045	
External finish		Pre-coated galvanized steel sheets (+powder coating for -BS type) <MUNSELL 5Y 8/1 or similar>			
External dimension HxWxD	mm	1,710(1,650 without legs) x 1,750 x 760	1,710(1,650 without legs) x 1,750 x 760	1,710(1,650 without legs) x 1,750 x 760	
	in.	67-3/8(65 without legs) x 68-15/16 x 29-15/16	67-3/8(65 without legs) x 68-15/16 x 29-15/16	67-3/8(65 without legs) x 68-15/16 x 29-15/16	
Protection devices	High pressure protection	High pressure sensor, High pressure switch at 4.15MPa (601 psi)			
	Inverter circuit (COMP/FAN)	Over-heat protection, Over-current protection			
	Compressor	Over-heat protection			
	Fan motor	Thermal switch			
Refrigerant	Type x original charge	R410A x 11.8kg (27lbs)	R410A x 11.8kg (27lbs)	R410A x 11.8kg (27lbs)	
	Net weight kg (lbs)	290(640)	290(640)	290(640)	
Heat exchanger		Salt-resistant cross fin & copper tube			
Pipe between unit and distributor	Liquid pipe mm (in.)	12.7(1/2) Brazed	12.7(1/2) Brazed	12.7(1/2) Brazed	
	Gas pipe mm (in.)	22.2(7/8) Brazed	22.2(7/8) Brazed	22.2(7/8) Brazed	
Optional parts		Outdoor Twinning kit: CMY-Y300VBK2 Joint: CMY-Y102SS/LS-G2, CMY-Y202S/302S-G2 Header: CMY-Y104/108/1010-G			

### Notes:

\*1,\*2 Nominal conditions

	Indoor	Outdoor	Pipe length	Level difference
Cooling	27°C DB/19°C WB (81°F DB/66°F WB)	35°C DB(95°F DB)	7.5m (24-9/16ft.)	0m (0ft.)
Heating	20°C DB(68°F DB)	7°C DB/6°C WB(45°F DB/43°F WB)	7.5m (24-9/16ft.)	0m (0ft.)

\*3 External static pressure option is available (30Pa, 60Pa / 3.1mmH<sub>2</sub>O, 6.1mmH<sub>2</sub>O).

\*Nominal condition \*1,\*2 are subject to JIS B8615-1.

\*Due to continuing improvement, above specification may be subject to change without notice.

# OUTDOOR UNIT ZUBADAN (Heat Pump) Series(Y) PUHY-HP Y(S)HM-A(-BS)



## ► Specifications

Set name	PUHY-HP200YHM-A(-BS)	PUHY-HP250YHM-A(-BS)	PUHY-HP400YSHM-A(-BS)	PUHY-HP500YSHM-A(-BS)	
Power source	3-phase 4-wire 380-400-415V 50/60Hz				
Cooling capacity (Nominal)	*1 kW	22.4	28.0	45.0	56.0
	*1 BTU/h	76,400	95,500	153,500	191,100
	Power input kW	6.40	9.06	12.86	18.16
	Current input A	10.8-10.2-9.8	15.2-14.5-14.0	21.7-20.6-19.8	30.6-29.1-28.0
COP	kW/kW	3.50	3.09	3.49	3.08
	W.B.	15 ~ 24°C (59 ~ 75°F)			
Temp. range of cooling	Indoor	15 ~ 24°C (59 ~ 75°F)			
	Outdoor	- 5 ~ 43°C (23 ~ 109°F)			
Heating capacity (Nominal)	*2 kW	25.0	31.5	50.0	63.0
	*2 BTU/h	85,300	107,500	170,600	215,000
	Power input kW	6.52	8.94	13.35	18.04
	Current input A	11.0-10.4-10.0	15.0-14.3-13.8	22.5-21.4-20.6	30.4-28.9-27.8
COP	kW/kW	3.83	3.52	3.74	3.49
	D.B.	15 ~ 27°C (59 ~ 81°F)			
Temp. range of heating	Indoor	15 ~ 27°C (59 ~ 81°F)			
	Outdoor	-25 ~ 15.5°C (-13 ~ 60°F)			
Indoor unit connectable	Total capacity	50 ~ 130% of outdoor unit capacity			
	Model/Quantity	P15~P250 / 1~17	P15 ~ P250 / 1 ~ 21	P15 ~ P250 / 1 ~ 34	P15 ~ P250 / 1 ~ 43
Sound pressure level (measured in anechoic room)	dB<A>	56	57	59	60
	Diameter of liquid pipe mm(in.)	ø12.7 (ø1/2) Brazed	ø12.7 (ø1/2) Brazed	ø15.88 (ø5/8) Brazed	ø15.88 (ø5/8) Brazed
Refrigerant pipe	Gas pipe mm(in.)	ø19.05 (ø3/4) Brazed	ø22.2 (ø7/8) Brazed	ø28.58 (ø1-1/8) Brazed	ø28.58 (ø1-1/8) Brazed
	Model	-			
External finish	Pre-coated galvanized steel sheets <MUNSELL 5Y 8/1 or similar>	Pre-coated galvanized steel sheets <MUNSELL 5Y 8/1 or similar>			
	mm	1,710 (without legs 1,650) x 920 x 760	1,710 (without legs 1,650) x 920 x 760	1,710 (without legs 1,650) x 920 x 760	1,710 (without legs 1,650) x 920 x 760
External dimension H x W x D	in.	67-3/8 (without legs 65) x 36-1/4 x 29-15/16	67-3/8 (without legs 65) x 36-1/4 x 29-15/16	67-3/8 (without legs 65) x 36-1/4 x 29-15/16	67-3/8 (without legs 65) x 36-1/4 x 29-15/16
	kg(lbs)	220 (486)	220 (486)	220 (486)	220 (486)
Heat exchanger	Type	Salt-resistant cross fin & copper tube			
	Starting method	Inverter scroll hermetic compressor			
Compressor	Type x Quantity	Inverter scroll hermetic compressor			
	Starting method	Inverter			
FAN	Motor output kW	5.3	6.7	5.3	6.7
	Air flow rate m³/min	225	225	225	225
FAN	L/s	3,750	3,750	3,750	3,750
	cfm	7,945	7,945	7,945	7,945
FAN	Type x Quantity	Propeller fan x 1			
	Motor output kW	0.92 x 1	0.92 x 1	0.92 x 1	0.92 x 1
Protection devices	High pressure protection	High pressure sensor, High pressure switch at 4.15 MPa (601 psi)			
	Inverter circuit (COMP./FAN)	Over-heat protection, Over-current protection			
Compressor	High pressure protection	High pressure sensor, High pressure switch at 4.15 MPa (601 psi)			
	Over-heat protection	Over-heat protection, Over-current protection			
Refrigerant	Type x Original charge	R410A x 9.0kg (20 lbs)			
	Pipe between unit distributor	Liquid pipe mm(in.)	-	-	ø9.52 (ø3/8) Flare
Optional parts	Gas pipe mm(in.)	-	-	ø19.05 (ø3/4) Brazed	ø19.05 (ø3/4) Brazed
	Joint : CMY-Y102SS-G2 Header : CMY-Y104/108/1010-G	Outdoor Twinning kit : CMY-Y100VBK2 Joint : CMY-Y102SS/LS-G2, CMY-Y202S-G2 Header : CMY-Y104/108/1010-G			

### Notes:

\*1,\*2 Nominal conditions

	Indoor	Outdoor	Pipe length	Level difference
Cooling	27°C DB/19°C WB (81°F DB/66°F WB)	35°C DB(95°F DB)	7.5m (24-9/16ft.)	0m (0ft.)
Heating	20°C DB(68°F DB)	7°C DB/6°C WB(45°F DB/43°F WB)	7.5m (24-9/16ft.)	0m (0ft.)

\*3 External static pressure option is available (30Pa, 60Pa / 3.1mmH<sub>2</sub>O, 6.1mmH<sub>2</sub>O).

\*Nominal condition \*1,\*2 are subject to JIS B8615-1.

\*Due to continuing improvement, above specification may be subject to change without notice.

# HEAT SOURCE UNIT WY (Heat Pump) Series PQHY-P YHM-A



## ► Specifications

Model	PQHY-P200YHM-A	PQHY-P250YHM-A	PQHY-P300YHM-A	
Power source	3-phase 4-wire 380-400-415V 50/60Hz			
Cooling capacity (Nominal)	*1 kW	22.4	28.0	33.5
	*1 BTU / h	76,400	95,500	114,300
	Power input kW	3.92	5.45	7.36
	Current input A	6.6-6.2-6.0	9.2-8.7-8.4	12.4-11.8-11.3
COP	kW / kW	5.71	5.13	4.55
	W.B.	15.0~24.0°C(59~75°F)		
Temp. range of cooling	Indoor	15.0~24.0°C(59~75°F)		
	Circulating water	10.0~45.0°C(50~113°F)		
Heating capacity (Nominal)	*2 kW	25.0	31.5	37.5
	*2 BTU / h	85,300	107,500	128,000
	Power input kW	4.12	5.80	8.15
	Current input A	6.9-6.6-6.3	9.7-9.3-8.9	13.7-13.0-12.5
COP	kW / kW	6.06	5.43	4.60
	D.B.	15.0~27.0°C(59~81°F)		
Temp. range of heating	Indoor	15.0~27.0°C(59~81°F)		
	Circulating water	10.0~45.0°C(50~113°F)		
Indoor unit connectable	Total capacity	50~130 % of heat source unit capacity		
	Model / Quantity	P15~P250 / 1~17		
Sound pressure level (measured in anechoic room)	dB <A>	47	49	50
	Refrigerant piping diameter [O.D.]	Liquid pipe mm (in.)	9.52(3/8) Brazed	9.52(3/8) Brazed (12.7(1/2) Brazed, total length >= 90m)
Circulating water	Gas pipe mm (in.)	19.05(3/4) Brazed		
	Water flow rate m³ / h	5.76	5.76	5.76
	L/min	96	96	96
	cfm	3.4	3.4	3.4
Pressure drop	kPa	17	17	17
	Operating volume range m³ / h	4.5 ~ 7.2	4.5 ~ 7.2	4.5 ~ 7.2
Compressor	Type x Quantity	Inverter scroll hermetic compressor		
	Starting method	Inverter		
	Motor output kW	4.6	6.3	7.4
	Case heater kW	0.035(240 V)	0.035(240 V)	0.035(240 V)
External finish	Acrylic painted steel plate	Acrylic painted steel plate		
	External dimension HxWxD	mm	1,160(1,100 without legs) x 880 x 550	1,160(1,100 without legs) x 880 x 550
Protection devices	High pressure protection	High pressure sensor, High pressure switch at 4.15MPa (601 psi)		
	Inverter circuit (COMP.)	Over-heat protection, Over-current protection		
Refrigerant	Type x original charge	R410A x 5.0kg (12lbs)		
	Net weight	195(430)		
Heat exchanger	Water volume in plate	5.0		
	Water pressure Max.	2.0		
Optional parts	Joint: CMY-Y102SS-G2 Header: CMY-Y104/108/1010-G	Joint: CMY-Y102SS-G2, CMY-Y102LS-G2 Header: CMY-Y104/108/1010-G		

### Notes:

\*1,\*2 Nominal conditions

	Indoor	Water temperature	Pipe length	Level difference
Cooling	27°C DB/19°CWB (81°FDB/66°FWB)	30°C (86°F)	7.5m (24-9/16ft.)	0m (0ft.)
Heating	20°CDB. (68°FDB.)	20°C (68°F)		

\*3 The ambient temperature of the heat source unit needs to be kept below 40°CDB.

\*4 The ambient relative humidity of the heat source unit needs to be kept below 80%.

\*5 The heat source Unit should not be installed at outdoor.

\*6 Be sure to mount a strainer (more than 50 meshes) at the water inlet piping of the unit.

\*7 Be sure to provide interlocking for the unit operation and water circuit.

\*Nominal condition \*1,\*2 are subject to JIS B8615-1.

\*Due to continuing improvement, above specification may be subject to change without notice.

# HEAT SOURCE UNIT WY (Heat Pump) Series PQHY-P YSHM-A



## > Specifications

Model	PQHY-P400YSHM-A		PQHY-P450YSHM-A		PQHY-P500YSHM-A	
Power source	3-phase 4-wire 380-400-415V 50/60Hz		3-phase 4-wire 380-400-415V 50/60Hz		3-phase 4-wire 380-400-415V 50/60Hz	
Cooling capacity (Nominal)	*1	kW	45.0		50.0	
	*1	BTU / h	153,500		170,600	
		Power input	8.25		9.84	
		Current input	13.9-13.2-12.7		16.6-15.7-15.2	
Temp. range of cooling		COP	5.45		5.08	
	Indoor	W.B.	15.0~24.0°C(59~75°F)		15.0~24.0°C(59~75°F)	
	Circulating water	°C	10.0~45.0°C(50~113°F)		10.0~45.0°C(50~113°F)	
		°C	10.0~45.0°C(50~113°F)		10.0~45.0°C(50~113°F)	
Heating capacity (Nominal)	*2	kW	50.0		63.0	
	*2	BTU / h	170,600		215,000	
		Power input	8.65		10.42	
		Current input	14.6-13.8-13.3		17.5-16.7-16.1	
Temp. range of heating		COP	5.78		5.22	
	Indoor	D.B.	15.0~27.0°C(59~81°F)		15.0~27.0°C(59~81°F)	
	Circulating water	°C	10.0~45.0°C(50~113°F)		10.0~45.0°C(50~113°F)	
		°C	10.0~45.0°C(50~113°F)		10.0~45.0°C(50~113°F)	
Indoor unit connectable	Total capacity	50~130 % of heat source unit capacity		50~130 % of heat source unit capacity		
	Model / Quantity	P15~P250 / 1~34		P15~P250 / 1~39		
Sound pressure level (measured in anechoic room)	dB <A>	50		51		
Refrigerant piping diameter [O.D.]	Liquid pipe	12.7(1/2) Braze		15.88(5/8) Braze		
	Gas pipe	28.58(1-1/8) Braze		28.58(1-1/8) Braze		

Model	PQHY-P200YHM-A		PQHY-P200YHM-A		PQHY-P250YHM-A		PQHY-P250YHM-A	
Circulating water	Water flow rate	m <sup>3</sup> / h	5.76 + 5.76		5.76 + 5.76		5.76 + 5.76	
		L/min	96 + 96		96 + 96		96 + 96	
		cfm	3.4 + 3.4		3.4 + 3.4		3.4 + 3.4	
	Pressure drop	kPa	17		17		17	
Operating volume range	m <sup>3</sup> / h	4.5 + 4.5 ~ 7.2 + 7.2		4.5 + 4.5 ~ 7.2 + 7.2		4.5 + 4.5 ~ 7.2 + 7.2		
Compressor	Type x Quantity	Inverter scroll hermetic compressor		Inverter scroll hermetic compressor		Inverter scroll hermetic compressor		
	Starting method	Inverter		Inverter		Inverter		
	Motor output	4.6		6.3		6.3		
	Case heater	0.035(240 V)		0.035(240 V)		0.035(240 V)		
External finish	Acrylic painted steel plate		Acrylic painted steel plate		Acrylic painted steel plate		Acrylic painted steel plate	
External dimension HxWxD	mm	1,160(1,100 without legs) x 880 x 550		1,160(1,100 without legs) x 880 x 550		1,160(1,100 without legs) x 880 x 550		
		45-11/16(43-5/16 without legs) x 34-11/16 x 21-11/16		45-11/16(43-5/16 without legs) x 34-11/16 x 21-11/16		45-11/16(43-5/16 without legs) x 34-11/16 x 21-11/16		
Protection devices	High pressure protection	High pressure sensor, High pressure switch at 4.15MPa (601 psi)		High pressure sensor, High pressure switch at 4.15MPa (601 psi)		High pressure sensor, High pressure switch at 4.15MPa (601 psi)		
	Inverter circuit (COMP.)	Over-heat protection, Over-current protection		Over-heat protection, Over-current protection		Over-heat protection, Over-current protection		
	Compressor	Over-heat protection		Over-heat protection		Over-heat protection		
Refrigerant	Type x original charge	R410A x 5.0kg (12lbs)		R410A x 5.0kg (12lbs)		R410A x 5.0kg (12lbs)		
Net weight	kg (lbs)	195(430)		195(430)		195(430)		
Heat exchanger	Water volume in plate	L		5.0		5.0		
	Water pressure Max.	MPa		2.0		2.0		
Optional parts	Heat Source Twinning kit: CMY-Y100VBK2 Joint: CMY-Y102SS-G2, CMY-Y102LS-G2, CMY-Y202S-G2 Header: CMY-Y104/108/1010-G		Heat Source Twinning kit: CMY-Y100VBK2 Joint: CMY-Y102SS-G2, CMY-Y102LS-G2, CMY-Y202S-G2 Header: CMY-Y104/108/1010-G		Heat Source Twinning kit: CMY-Y100VBK2 Joint: CMY-Y102SS-G2, CMY-Y102LS-G2, CMY-Y202S-G2 Header: CMY-Y104/108/1010-G		Heat Source Twinning kit: CMY-Y100VBK2 Joint: CMY-Y102SS-G2, CMY-Y102LS-G2, CMY-Y202S-G2 Header: CMY-Y104/108/1010-G	

### Notes:

\*1, \*2 Nominal conditions

	Indoor	Water temperature	Pipe length	Level difference
Cooling	27°C D.B./19°C W.B. (81°F D.B./66°F W.B.)	30°C (86°F)	7.5m (24-9/16ft.)	0m (0ft.)
Heating	20°C D.B. (68°F D.B.)	20°C (68°F)		

- \*3 The ambient temperature of the heat source unit needs to be kept below 40°C D.B.
- \*4 The ambient relative humidity of the heat source unit needs to be kept below 80%.
- \*5 The heat source Unit should not be installed at outdoor.
- \*6 Be sure to mount a strainer (more than 50 meshes) at the water inlet piping of the unit.
- \*7 Be sure to provide interlocking for the unit operation and water circuit.
- \*Nominal condition \*1, \*2 are subject to JIS B8615-1.
- \*Due to continuing improvement, above specification may be subject to change without notice.

Outdoor unit

# HEAT SOURCE UNIT WY (Heat Pump) Series PQHY-P YSHM-A



## > Specifications

Model	PQHY-P550YSHM-A		PQHY-P600YSHM-A	
Power source	3-phase 4-wire 380-400-415V 50/60Hz		3-phase 4-wire 380-400-415V 50/60Hz	
Cooling capacity (Nominal)	*1	kW	63.0	
	*1	BTU / h	215,000	
		Power input	13.46	
		Current input	22.7-21.5-20.8	
Temp. range of cooling		COP	4.68	
	Indoor	W.B.	15.0~24.0°C(59~75°F)	
	Circulating water	°C	10.0~45.0°C(50~113°F)	
		°C	10.0~45.0°C(50~113°F)	
Heating capacity (Nominal)	*2	kW	69.0	
	*2	BTU / h	235,400	
		Power input	14.65	
		Current input	24.7-23.4-22.6	
Temp. range of heating		COP	4.70	
	Indoor	D.B.	15.0~27.0°C(59~81°F)	
	Circulating water	°C	10.0~45.0°C(50~113°F)	
		°C	10.0~45.0°C(50~113°F)	
Indoor unit connectable	Total capacity	50~130 % of heat source unit capacity		
	Model / Quantity	P15~P250 / 2~47		
Sound pressure level (measured in anechoic room)	dB <A>	52.5		
Refrigerant piping diameter [O.D.]	Liquid pipe	15.88(5/8) Braze		
	Gas pipe	28.58(1-1/8) Braze		

Model	PQHY-P300YHM-A		PQHY-P250YHM-A		PQHY-P300YHM-A		PQHY-P300YHM-A	
Circulating water	Water flow rate	m <sup>3</sup> / h	5.76 + 5.76		5.76 + 5.76		5.76 + 5.76	
		L/min	96 + 96		96 + 96		96 + 96	
		cfm	3.4 + 3.4		3.4 + 3.4		3.4 + 3.4	
	Pressure drop	kPa	17		17		17	
Operating volume range	m <sup>3</sup> / h	4.5 + 4.5 ~ 7.2 + 7.2		4.5 + 4.5 ~ 7.2 + 7.2		4.5 + 4.5 ~ 7.2 + 7.2		
Compressor	Type x Quantity	Inverter scroll hermetic compressor		Inverter scroll hermetic compressor		Inverter scroll hermetic compressor		
	Starting method	Inverter		Inverter		Inverter		
	Motor output	7.4		6.3		7.4		
	Case heater	0.035(240 V)		0.035(240 V)		0.035(240 V)		
External finish	Acrylic painted steel plate		Acrylic painted steel plate		Acrylic painted steel plate		Acrylic painted steel plate	
External dimension HxWxD	mm	1,160(1,100 without legs) x 880 x 550		1,160(1,100 without legs) x 880 x 550		1,160(1,100 without legs) x 880 x 550		
		45-11/16(43-5/16 without legs) x 34-11/16 x 21-11/16		45-11/16(43-5/16 without legs) x 34-11/16 x 21-11/16		45-11/16(43-5/16 without legs) x 34-11/16 x 21-11/16		
Protection devices	High pressure protection	High pressure sensor, High pressure switch at 4.15MPa (601 psi)		High pressure sensor, High pressure switch at 4.15MPa (601 psi)		High pressure sensor, High pressure switch at 4.15MPa (601 psi)		
	Inverter circuit (COMP.)	Over-heat protection, Over-current protection		Over-heat protection, Over-current protection		Over-heat protection, Over-current protection		
	Compressor	Over-heat protection		Over-heat protection		Over-heat protection		
Refrigerant	Type x original charge	R410A x 5.0kg (12lbs)		R410A x 5.0kg (12lbs)		R410A x 5.0kg (12lbs)		
Net weight	kg (lbs)	195(430)		195(430)		195(430)		
Heat exchanger	Water volume in plate	L		5.0		5.0		
	Water pressure Max.	MPa		2.0		2.0		
Optional parts	Heat Source Twinning kit: CMY-Y100VBK2 Joint: CMY-Y102SS-G2, CMY-Y102LS-G2, CMY-Y202S-G2 Header: CMY-Y104/108/1010-G		Heat Source Twinning kit: CMY-Y100VBK2 Joint: CMY-Y102SS-G2, CMY-Y102LS-G2, CMY-Y202S-G2 Header: CMY-Y104/108/1010-G		Heat Source Twinning kit: CMY-Y100VBK2 Joint: CMY-Y102SS-G2, CMY-Y102LS-G2, CMY-Y202S-G2 Header: CMY-Y104/108/1010-G		Heat Source Twinning kit: CMY-Y100VBK2 Joint: CMY-Y102SS-G2, CMY-Y102LS-G2, CMY-Y202S-G2 Header: CMY-Y104/108/1010-G	

### Notes:

\*1, \*2 Nominal conditions

	Indoor	Water temperature	Pipe length	Level difference
Cooling	27°C D.B./19°C W.B. (81°F D.B./66°F W.B.)	30°C (86°F)	7.5m (24-9/16ft.)	0m (0ft.)
Heating	20°C D.B. (68°F D.B.)	20°C (68°F)		

- \*3 The ambient temperature of the heat source unit needs to be kept below 40°C D.B.
- \*4 The ambient relative humidity of the heat source unit needs to be kept below 80%.
- \*5 The heat source Unit should not be installed at outdoor.
- \*6 Be sure to mount a strainer (more than 50 meshes) at the water inlet piping of the unit.
- \*7 Be sure to provide interlocking for the unit operation and water circuit.
- \*Nominal condition \*1, \*2 are subject to JIS B8615-1.
- \*Due to continuing improvement, above specification may be subject to change without notice.

Outdoor Unit

# HEAT SOURCE UNIT WY (Heat Pump) Series PQHY-P YSHM-A



## > Specifications

Model		PQHY-P650YSHM-A		PQHY-P700YSHM-A	
Power source		3-phase 4-wire 380-400-415V 50/60Hz		3-phase 4-wire 380-400-415V 50/60Hz	
Cooling capacity (Nominal)	*1 kW	73.0		80.0	
	*1 BTU / h	249,100		273,000	
	Power input kW	13.96		15.58	
	Current input A	23.5-22.3-21.5		26.3-24.9-24.0	
	COP	5.22		5.13	
Temp. range of cooling	Indoor W.B.	15.0~24.0°C(59~75°F)		15.0~24.0°C(59~75°F)	
	Circulating water °C	10.0~45.0°C(50~113°F)		10.0~45.0°C(50~113°F)	
Heating capacity (Nominal)	*2 kW	81.5		88.0	
	*2 BTU / h	278,100		300,300	
	Power input kW	14.74		16.51	
	Current input A	24.8-23.6-22.7		27.8-26.4-25.5	
	COP	5.52		5.33	
Temp. range of heating	Indoor D.B.	15.0~27.0°C(59~81°F)		15.0~27.0°C(59~81°F)	
	Circulating water °C	10.0~45.0°C(50~113°F)		10.0~45.0°C(50~113°F)	
Indoor unit connectable	Total capacity	50~130 % of heat source unit capacity		50~130 % of heat source unit capacity	
	Model / Quantity	P15~P250 / 2~50		P15~P250 / 2~50	
Sound pressure level (measured in anechoic room)	dB <A>	53		53.5	
Refrigerant piping diameter [O.D.]	Liquid pipe mm (in.)	19.05(3/4) Brazed		19.05(3/4) Brazed	
	Gas pipe mm (in.)	34.93(1-3/8) Brazed		34.93(1-3/8) Brazed	

Model		PQHY-P250YHM-A	PQHY-P200YHM-A	PQHY-P200YHM-A	PQHY-P250YHM-A	PQHY-P250YHM-A	PQHY-P200YHM-A
Circulating water	Water flow rate m <sup>3</sup> / h	5.76 + 5.76 + 5.76			5.76 + 5.76 + 5.76		
	L/min	96 + 96 + 96			96 + 96 + 96		
	cfm	3.4 + 3.4 + 3.4			3.4 + 3.4 + 3.4		
	Pressure drop kPa	17	17	17	17	17	17
Operating volume range	m <sup>3</sup> / h	4.5 + 4.5 + 4.5 ~ 7.2 + 7.2 + 7.2			4.5 + 4.5 + 4.5 ~ 7.2 + 7.2 + 7.2		
Compressor	Type x Quantity	Inverter scroll hermetic compressor			Inverter scroll hermetic compressor		
	Starting method	Inverter			Inverter		
	Motor output kW	6.3	4.6	4.6	6.3	6.3	4.6
	Case heater kW	0.035(240 V)	0.035(240 V)	0.035(240 V)	0.035(240 V)	0.035(240 V)	0.035(240 V)
External finish		Acrylic painted steel plate			Acrylic painted steel plate		
External dimension HxWxD	mm	1,160(1,100 without legs) x 880 x 550	1,160(1,100 without legs) x 880 x 550	1,160(1,100 without legs) x 880 x 550	1,160(1,100 without legs) x 880 x 550	1,160(1,100 without legs) x 880 x 550	1,160(1,100 without legs) x 880 x 550
	in.	45-11/16(43-5/16 without legs) x 34-11/16 x 21-11/16	45-11/16(43-5/16 without legs) x 34-11/16 x 21-11/16	45-11/16(43-5/16 without legs) x 34-11/16 x 21-11/16	45-11/16(43-5/16 without legs) x 34-11/16 x 21-11/16	45-11/16(43-5/16 without legs) x 34-11/16 x 21-11/16	45-11/16(43-5/16 without legs) x 34-11/16 x 21-11/16
Protection devices	High pressure protection	High pressure sensor, High pressure switch at 4.15MPa (601 psi)			High pressure sensor, High pressure switch at 4.15MPa (601 psi)		
	Inverter circuit (COMP.)	Over-heat protection, Over-current protection			Over-heat protection, Over-current protection		
	Compressor	Over-heat protection			Over-heat protection		
Refrigerant	Type x original charge	R410A x 5.0kg (12lbs)	R410A x 5.0kg (12lbs)	R410A x 5.0kg (12lbs)	R410A x 5.0kg (12lbs)	R410A x 5.0kg (12lbs)	R410A x 5.0kg (12lbs)
Net weight	kg (lbs)	195(430)	195(430)	195(430)	195(430)	195(430)	195(430)
Heat exchanger	Water volume in plate	L	5.0	5.0	5.0	5.0	5.0
	Water pressure Max.	MPa	2.0	2.0	2.0	2.0	2.0
Optional parts		Heat Source Twinning kit: CMY-Y300VBK2 Joint: CMY-Y102SS-G2, CMY-Y102LS-G2, CMY-Y202S-G2, CMY-Y302S-G2 Header: CMY-Y104/108/1010-G			Heat Source Twinning kit: CMY-Y300VBK2 Joint: CMY-Y102SS-G2, CMY-Y102LS-G2, CMY-Y202S-G2, CMY-Y302S-G2 Header: CMY-Y104/108/1010-G		

### Notes:

\*1, \*2 Nominal conditions

	Indoor	Water temperature	Pipe length	Level difference
Cooling	27°C D.B./19°C W.B. (81°F D.B./66°F W.B.)	30°C (86°F)	7.5m (24-9/16ft.)	0m (0ft.)
Heating	20°C D.B. (68°F D.B.)	20°C (68°F)		

- \*3 The ambient temperature of the heat source unit needs to be kept below 40°C D.B.
- \*4 The ambient relative humidity of the heat source unit needs to be kept below 80%.
- \*5 The heat source Unit should not be installed at outdoor.
- \*6 Be sure to mount a strainer (more than 50 meshes) at the water inlet piping of the unit.
- \*7 Be sure to provide interlocking for the unit operation and water circuit.
- \*Nominal condition \*1, \*2 are subject to JIS B8615-1.
- \*Due to continuing improvement, above specification may be subject to change without notice.

Outdoor unit

# HEAT SOURCE UNIT WY (Heat Pump) Series PQHY-P YSHM-A



## > Specifications

Model		PQHY-P750YSHM-A		PQHY-P800YSHM-A	
Power source		3-phase 4-wire 380-400-415V 50/60Hz		3-phase 4-wire 380-400-415V 50/60Hz	
Cooling capacity (Nominal)	*1 kW	85.0		90.0	
	*1 BTU / h	290,000		307,100	
	Power input kW	17.19		19.18	
	Current input A	29.0-27.5-26.5		32.3-30.7-29.6	
	COP	4.94		4.69	
Temp. range of cooling	Indoor W.B.	15.0~24.0°C(59~75°F)		15.0~24.0°C(59~75°F)	
	Circulating water °C	10.0~45.0°C(50~113°F)		10.0~45.0°C(50~113°F)	
Heating capacity (Nominal)	*2 kW	95.0		100.0	
	*2 BTU / h	324,100		341,200	
	Power input kW	18.27		20.74	
	Current input A	30.8-29.3-28.2		35.0-33.2-32.0	
	COP	5.19		4.82	
Temp. range of heating	Indoor D.B.	15.0~27.0°C(59~81°F)		15.0~27.0°C(59~81°F)	
	Circulating water °C	10.0~45.0°C(50~113°F)		10.0~45.0°C(50~113°F)	
Indoor unit connectable	Total capacity	50~130 % of heat source unit capacity		50~130 % of heat source unit capacity	
	Model / Quantity	P15~P250 / 2~50		P15~P250 / 2~50	
Sound pressure level (measured in anechoic room)	dB <A>	54		54	
Refrigerant piping diameter [O.D.]	Liquid pipe mm (in.)	19.05(3/4) Brazed		19.05(3/4) Brazed	
	Gas pipe mm (in.)	34.93(1-3/8) Brazed		34.93(1-3/8) Brazed	

Model		PQHY-P250YHM-A	PQHY-P250YHM-A	PQHY-P250YHM-A	PQHY-P300YHM-A	PQHY-P250YHM-A	PQHY-P250YHM-A
Circulating water	Water flow rate m <sup>3</sup> / h	5.76 + 5.76 + 5.76			5.76 + 5.76 + 5.76		
	L/min	96 + 96 + 96			96 + 96 + 96		
	cfm	3.4 + 3.4 + 3.4			3.4 + 3.4 + 3.4		
	Pressure drop kPa	17	17	17	17	17	17
Operating volume range	m <sup>3</sup> / h	4.5 + 4.5 + 4.5 ~ 7.2 + 7.2 + 7.2			4.5 + 4.5 + 4.5 ~ 7.2 + 7.2 + 7.2		
Compressor	Type x Quantity	Inverter scroll hermetic compressor			Inverter scroll hermetic compressor		
	Starting method	Inverter			Inverter		
	Motor output kW	6.3	6.3	6.3	7.4	6.3	6.3
	Case heater kW	0.035(240 V)	0.035(240 V)	0.035(240 V)	0.035(240 V)	0.035(240 V)	0.035(240 V)
External finish		Acrylic painted steel plate			Acrylic painted steel plate		
External dimension HxWxD	mm	1,160(1,100 without legs) x 880 x 550	1,160(1,100 without legs) x 880 x 550	1,160(1,100 without legs) x 880 x 550	1,160(1,100 without legs) x 880 x 550	1,160(1,100 without legs) x 880 x 550	1,160(1,100 without legs) x 880 x 550
	in.	45-11/16(43-5/16 without legs) x 34-11/16 x 21-11/16	45-11/16(43-5/16 without legs) x 34-11/16 x 21-11/16	45-11/16(43-5/16 without legs) x 34-11/16 x 21-11/16	45-11/16(43-5/16 without legs) x 34-11/16 x 21-11/16	45-11/16(43-5/16 without legs) x 34-11/16 x 21-11/16	45-11/16(43-5/16 without legs) x 34-11/16 x 21-11/16
Protection devices	High pressure protection	High pressure sensor, High pressure switch at 4.15MPa (601 psi)			High pressure sensor, High pressure switch at 4.15MPa (601 psi)		
	Inverter circuit (COMP.)	Over-heat protection, Over-current protection			Over-heat protection, Over-current protection		
	Compressor	Over-heat protection			Over-heat protection		
Refrigerant	Type x original charge	R410A x 5.0kg (12lbs)	R410A x 5.0kg (12lbs)	R410A x 5.0kg (12lbs)	R410A x 5.0kg (12lbs)	R410A x 5.0kg (12lbs)	R410A x 5.0kg (12lbs)
Net weight	kg (lbs)	195(430)	195(430)	195(430)	195(430)	195(430)	195(430)
Heat exchanger	Water volume in plate	L	5.0	5.0	5.0	5.0	5.0
	Water pressure Max.	MPa	2.0	2.0	2.0	2.0	2.0
Optional parts		Heat Source Twinning kit: CMY-Y300VBK2 Joint: CMY-Y102SS-G2, CMY-Y102LS-G2, CMY-Y202S-G2, CMY-Y302S-G2 Header: CMY-Y104/108/1010-G			Heat Source Twinning kit: CMY-Y300VBK2 Joint: CMY-Y102SS-G2, CMY-Y102LS-G2, CMY-Y202S-G2, CMY-Y302S-G2 Header: CMY-Y104/108/1010-G		

### Notes:

\*1, \*2 Nominal conditions

	Indoor	Water temperature	Pipe length	Level difference
Cooling	27°C D.B./19°C W.B. (81°F D.B./66°F W.B.)	30°C (86°F)	7.5m (24-9/16ft.)	0m (0ft.)
Heating	20°C D.B. (68°F D.B.)	20°C (68°F)		

- \*3 The ambient temperature of the heat source unit needs to be kept below 40°C D.B.
- \*4 The ambient relative humidity of the heat source unit needs to be kept below 80%.
- \*5 The heat source Unit should not be installed at outdoor.
- \*6 Be sure to mount a strainer (more than 50 meshes) at the water inlet piping of the unit.
- \*7 Be sure to provide interlocking for the unit operation and water circuit.
- \*Nominal condition \*1, \*2 are subject to JIS B8615-1.
- \*Due to continuing improvement, above specification may be subject to change without notice.

Outdoor unit

# HEAT SOURCE UNIT WY (Heat Pump) Series PQHY-P YSHM-A



## > Specifications

Model	PQHY-P850YSHM-A		PQHY-P900YSHM-A	
Power source	3-phase 4-wire 380-400-415V 50/60Hz		3-phase 4-wire 380-400-415V 50/60Hz	
Cooling capacity (Nominal)	*1 kW	96.0	101.0	
	*1 BTU / h	327,600	344,600	
	Power input kW	21.20	23.22	
	Current input A	35.7-33.9-32.7	39.1-37.2-35.8	
COP	kW / kW	4.52	4.34	
	W.B.	15.0~24.0°C(59~75°F)	15.0~24.0°C(59~75°F)	
Temp. range of cooling	Circulating water °C	10.0~45.0°C(50~113°F)	10.0~45.0°C(50~113°F)	
	Indoor W.B.	15.0~24.0°C(59~75°F)	15.0~24.0°C(59~75°F)	
Heating capacity (Nominal)	*2 kW	108.0	113.0	
	*2 BTU / h	368,500	385,600	
	Power input kW	23.21	25.67	
	Current input A	39.1-37.2-35.8	43.3-41.1-39.6	
COP	kW / kW	4.65	4.40	
	D.B.	15.0~27.0°C(59~81°F)	15.0~27.0°C(59~81°F)	
Temp. range of heating	Circulating water °C	10.0~45.0°C(50~113°F)	10.0~45.0°C(50~113°F)	
	Indoor W.B.	15.0~27.0°C(59~81°F)	15.0~27.0°C(59~81°F)	
Indoor unit connectable	Total capacity	50~130 % of heat source unit capacity		50~130 % of heat source unit capacity
	Model / Quantity	P15~P250 / 2~50		P15~P250 / 2~50
Sound pressure level (measured in anechoic room)	dB <A>	54.5		55
Refrigerant piping diameter [O.D.]	Liquid pipe mm (in.)	19.05(3/4) Brazed		19.05(3/4) Brazed
	Gas pipe mm (in.)	41.28(1-5/8) Brazed		41.28(1-5/8) Brazed

Model	PQHY-P300YHM-A			PQHY-P300YHM-A		
Circulating water	Water flow rate	m <sup>3</sup> / h	5.76 + 5.76 + 5.76			5.76 + 5.76 + 5.76
		L/min	96 + 96 + 96			96 + 96 + 96
	Pressure drop	kPa	17	17	17	17
		cfm	3.4 + 3.4 + 3.4			3.4 + 3.4 + 3.4
Operating volume range	m <sup>3</sup> / h	4.5 + 4.5 + 4.5 ~ 7.2 + 7.2 + 7.2			4.5 + 4.5 + 4.5 ~ 7.2 + 7.2 + 7.2	
	Type x Quantity	Inverter scroll hermetic compressor			Inverter scroll hermetic compressor	
Compressor	Starting method	Inverter			Inverter	
	Motor output kW	7.4	7.4	6.3	7.4	
	Case heater kW	0.035(240 V)	0.035(240 V)	0.035(240 V)	0.035(240 V)	
External finish	Acrylic painted steel plate			Acrylic painted steel plate		
	External dimension HxWxD	mm	1,160(1,100 without legs) x 880 x 550			1,160(1,100 without legs) x 880 x 550
in.		45-11/16(43-5/16 without legs) x 34-11/16 x 21-11/16			45-11/16(43-5/16 without legs) x 34-11/16 x 21-11/16	
Protection devices	High pressure protection	High pressure sensor, High pressure switch at 4.15MPa (601 psi)			High pressure sensor, High pressure switch at 4.15MPa (601 psi)	
	Inverter circuit (COMP.)	Over-heat protection, Over-current protection			Over-heat protection, Over-current protection	
Refrigerant	Type x original charge	R410A x 5.0kg (12lbs)	R410A x 5.0kg (12lbs)	R410A x 5.0kg (12lbs)	R410A x 5.0kg (12lbs)	
	Net weight	195(430)	195(430)	195(430)	195(430)	
Heat exchanger	Water volume in plate	L	5.0	5.0	5.0	
	Water pressure Max.	MPa	2.0	2.0	2.0	
Optional parts	Heat Source Twinning kit: CMY-Y300VBK2			Heat Source Twinning kit: CMY-Y300VBK2		
	Joint: CMY-Y102SS-G2, CMY-Y102LS-G2, CMY-Y202S-G2, CMY-Y302S-G2			Joint: CMY-Y102SS-G2, CMY-Y102LS-G2, CMY-Y202S-G2, CMY-Y302S-G2		
	Header: CMY-Y104/108/1010-G			Header: CMY-Y104/108/1010-G		

### Notes:

\*1, \*2 Nominal conditions

	Indoor	Water temperature	Pipe length	Level difference
Cooling	27°C DB/19°C WB (81°F DB/66°F WB)	30°C (86°F)	7.5m (24-9/16ft.)	0m (0ft.)
Heating	20°C DB (68°F DB)	20°C (68°F)		

- \*3 The ambient temperature of the heat source unit needs to be kept below 40°C DB.
- \*4 The ambient relative humidity of the heat source unit needs to be kept below 80%.
- \*5 The heat source Unit should not be installed at outdoor.
- \*6 Be sure to mount a strainer (more than 50 meshes) at the water inlet piping of the unit.
- \*7 Be sure to provide interlocking for the unit operation and water circuit.
- \*Nominal condition \*1, \*2 are subject to JIS B8615-1.
- \*Due to continuing improvement, above specification may be subject to change without notice.

Outdoor unit

# OUTDOOR UNIT R2 Series PURY-P YJM-A(-BS)



## > Specifications

Model	PURY-P200YJM-A(-BS)		PURY-P250YJM-A(-BS)		PURY-P300YJM-A(-BS)	
Power source	3-phase 4-wire 380-400-415V 50/60Hz		3-phase 4-wire 380-400-415V 50/60Hz		3-phase 4-wire 380-400-415V 50/60Hz	
Cooling capacity (Nominal)	*1 kW	22.4	28.0		33.5	
	*1 BTU / h	76,400	95,500		114,300	
	Power input kW	5.18	7.05		8.67	
	Current input A	8.7-8.3-8.0	11.9-11.3-10.8		14.6-13.9-13.4	
COP	kW / kW	4.32	3.97		3.86	
	W.B.	15.0~24.0°C(59~75°F)	15.0~24.0°C(59~75°F)		15.0~24.0°C(59~75°F)	
Temp. range of cooling	Indoor D.B.	15.0~24.0°C(59~75°F)	15.0~24.0°C(59~75°F)		15.0~24.0°C(59~75°F)	
	Outdoor W.B.	-5.0~46.0°C(23~115°F)	-5.0~46.0°C(23~115°F)		-5.0~46.0°C(23~115°F)	
Heating capacity (Nominal)	*2 kW	25.0	31.5		37.5	
	*2 BTU / h	85,300	107,500		128,000	
	Power input kW	5.69	7.32		8.78	
	Current input A	9.6-9.1-8.7	12.3-11.7-11.3		14.8-14.0-13.5	
COP	kW / kW	4.39	4.30		4.27	
	D.B.	15.0~27.0°C(59~81°F)	15.0~27.0°C(59~81°F)		15.0~27.0°C(59~81°F)	
Temp. range of heating	Indoor D.B.	15.0~27.0°C(59~81°F)	15.0~27.0°C(59~81°F)		15.0~27.0°C(59~81°F)	
	Outdoor W.B.	-20.0~15.5°C(-4~60°F)	-20.0~15.5°C(-4~60°F)		-20.0~15.5°C(-4~60°F)	
Indoor unit connectable	Total capacity	50~150 % of outdoor unit capacity		50~150 % of outdoor unit capacity		
	Model / Quantity	P15~P250 / 1~20		P15~P250 / 1~25		
Sound pressure level (measured in anechoic room)	dB <A>	56		57		
Power pressure level (measured in anechoic room)	dB <A>	76		77		
Refrigerant piping diameter	High pressure mm (in.)	15.88(5/8) Brazed		19.05(3/4) Brazed		
	Low pressure mm (in.)	19.05(3/4) Brazed		22.2(7/8) Brazed		
FAN	Type x Quantity	Propeller fan x 1		Propeller fan x 1		
	Air flow rate	m <sup>3</sup> /min	185		185	
		L/s	3,083		3,083	
	cfm	6,532		6,532		
Driving mechanism	Inverter-control, Direct-driven by motor		Inverter-control, Direct-driven by motor		Inverter-control, Direct-driven by motor	
	Motor output kW	0.92 x 1		0.92 x 1		
Compressor	External static press.	0 Pa (0 mmH <sub>2</sub> O)		0 Pa (0 mmH <sub>2</sub> O)		
	Type x Quantity	Inverter scroll hermetic compressor		Inverter scroll hermetic compressor		
	Starting method	Inverter		Inverter		
	Motor output kW	5.4		6.8		
Case heater kW	0.035(240 V)		0.035(240 V)			
External finish	Pre-coated galvanized steel sheets (+powder coating for -BS type) <MUNSELL 5Y 8/1 or similar>		Pre-coated galvanized steel sheets (+powder coating for -BS type) <MUNSELL 5Y 8/1 or similar>		Pre-coated galvanized steel sheets (+powder coating for -BS type) <MUNSELL 5Y 8/1 or similar>	
	External dimension HxWxD	mm	1,710(1,650 without legs) x 920 x 760		1,710(1,650 without legs) x 920 x 760	
in.		67-3/8(65 without legs) x 36-1/4 x 29-15/16		67-3/8(65 without legs) x 36-1/4 x 29-15/16		
Protection devices	High pressure protection	High pressure sensor, High pressure switch at 4.15MPa (601 psi)		High pressure sensor, High pressure switch at 4.15MPa (601 psi)		
	Inverter circuit (COMP./FAN)	Over-heat protection, Over-current protection		Over-heat protection, Over-current protection		
	Compressor	Over-heat protection		Over-heat protection		
	Fan motor	Thermal switch		Thermal switch		
Refrigerant	Type x original charge	R410A x 9.5kg (21lbs)		R410A x 9.5kg (21lbs)		
Net weight	kg (lbs)	240(530)		245(541)		
Heat exchanger		Salt-resistant cross fin & copper tube		Salt-resistant cross fin & copper tube		
Optional parts	Joint: CMY-Y102SS-G2, CMY-Y102LS-G2, CMY-R160-J1		Joint: CMY-Y102SS-G2, CMY-Y102LS-G2, CMY-R160-J1		Joint: CMY-Y102SS-G2, CMY-Y102LS-G2, CMY-R160-J1	
	BC controller: CMB-P104,105,106,108,1010,1013,1016V-G1		BC controller: CMB-P104,105,106,108,1010,1013,1016V-G1		BC controller: CMB-P104,105,106,108,1010,1013,1016V-G1	
	Main BC controller: CMB-P108,1010,1013,1016V-GA1		Main BC controller: CMB-P108,1010,1013,1016V-GA1		Main BC controller: CMB-P108,1010,1013,1016V-GA1	
	Sub BC controller: CMB-P104,108V-GB1,CMB-P1016V-HB1		Sub BC controller: CMB-P104,108V-GB1,CMB-P1016V-HB1		Sub BC controller: CMB-P104,108V-GB1,CMB-P1016V-HB1	

### Notes:

\*1, \*2 Nominal conditions

	Indoor	Outdoor	Pipe length	Level difference
Cooling	27°C DB/19°C WB (81°F DB/66°F WB)	35°C DB(95°F DB)	7.5m (24-9/16ft.)	0m (0ft.)
Heating	20°C DB(68°F DB)	7°C DB/6°C WB(45°F DB/43°F WB)		

- \*3 -5°C DB (23°F DB) / -6°C WB (21°F WB) to 21°C DB (70°F DB) / 15.5°C WB (60°F WB) with cooling/heating mixed operation.
- \*4 External static pressure option is available (30Pa, 60Pa / 3.1mmH<sub>2</sub>O, 6.1mmH<sub>2</sub>O).
- \*Nominal condition \*1, \*2 are subject to JIS B8615-1.
- \*Due to continuing improvement, above specification may be subject to change without notice.

Outdoor Unit

# OUTDOOR UNIT R2 Series PURY-P YJM-A(-BS)



## ► Specifications

Model	PURY-P350YJM-A(-BS)		PURY-P400YJM-A(-BS)		PURY-P450YJM-A(-BS)	
Power source	3-phase 4-wire 380-400-415V 50/60Hz					
Cooling capacity (Nominal)	*1 kW	40.0	45.0	50.0		
	*1 BTU/h	136,500	153,500	170,600		
	Power input kW	11.33	13.55	14.49		
	Current input A	19.1-18.1-17.5	22.8-21.7-20.9	24.4-23.2-22.3		
	COP kW/kW	3.53	3.32	3.45		
Temp. range of cooling *3	Indoor W.B.	15.0~24.0°C(59~75°F)	15.0~24.0°C(59~75°F)	15.0~24.0°C(59~75°F)		
	Outdoor D.B.	-5.0~46.0°C(23~115°F)	-5.0~46.0°C(23~115°F)	-5.0~46.0°C(23~115°F)		
Heating capacity (Nominal)	*2 kW	45.0	50.0	56.0		
	*2 BTU/h	153,500	170,600	191,100		
	Power input kW	10.89	12.75	14.58		
	Current input A	18.3-17.4-16.8	21.5-20.4-19.7	24.6-23.3-22.5		
	COP kW/kW	4.13	3.92	3.84		
Temp. range of heating *3	Indoor W.B.	15.0~27.0°C(59~81°F)	15.0~27.0°C(59~81°F)	15.0~27.0°C(59~81°F)		
	Outdoor W.B.	-20.0~15.5°C(-4~60°F)	-20.0~15.5°C(-4~60°F)	-20.0~15.5°C(-4~60°F)		
Indoor unit connectable	Total capacity	50~150 % of outdoor unit capacity	50~150 % of outdoor unit capacity	50~150 % of outdoor unit capacity		
Sound pressure level (measured in anechoic room)	dB <A>	60	61	62		
Power pressure level (measured in anechoic room)	dB <A>	80	81	82		
Refrigerant piping diameter	High pressure mm (in.)	19.05(3/4) Braze	22.2(7/8) Braze	22.2(7/8) Braze		
	Low pressure mm (in.)	28.58(1-1/8) Braze	28.58(1-1/8) Braze	28.58(1-1/8) Braze		
FAN	Type x Quantity	Propeller fan x 1	Propeller fan x 1	Propeller fan x 2		
	Air flow rate m³/min	225	225	360		
	L/s	3,750	6,000	6,000		
	cfm	7,945	7,945	12,712		
	Driving mechanism	Inverter-control, Direct-driven by motor	Inverter-control, Direct-driven by motor	Inverter-control, Direct-driven by motor		
	Motor output kW	0.92 x 1	0.92 x 1	0.92 x 2		
	*4 External static press.	0 Pa (0 mmH <sub>2</sub> O)	0 Pa (0 mmH <sub>2</sub> O)	0 Pa (0 mmH <sub>2</sub> O)		
	Type x Quantity	Inverter scroll hermetic compressor	Inverter scroll hermetic compressor	Inverter scroll hermetic compressor		
	Starting method	Inverter	Inverter	Inverter		
	Motor output kW	9.9	10.2	11.6		
Case heater kW	0.045(240 V)	0.045(240 V)	0.045(240 V)			
External finish	Pre-coated galvanized steel sheets (+powder coating for -BS type) <MUNSELL 5Y 8/1 or similar>					
External dimension HxWxD	mm	1,710(1,650 without legs) x 1,220 x 760	1,710(1,650 without legs) x 1,220 x 760	1,710(1,650 without legs) x 1,750 x 760		
	in.	67-3/8(65 without legs) x 48-1/16 x 29-15/16	67-3/8(65 without legs) x 48-1/16 x 29-15/16	67-3/8(65 without legs) x 68-15/16 x 29-15/16		
Protection devices	High pressure protection	High pressure sensor, High pressure switch at 4.15MPa (601 psi)	High pressure sensor, High pressure switch at 4.15MPa (601 psi)	High pressure sensor, High pressure switch at 4.15MPa (601 psi)		
	Inverter circuit (COMP./FAN)	Over-heat protection, Over-current protection	Over-heat protection, Over-current protection	Over-heat protection, Over-current protection		
	Compressor	Over-heat protection	Over-heat protection	Over-heat protection		
	Fan motor	Thermal switch	Thermal switch	Thermal switch		
Refrigerant	Type x original charge	R410A x 11.8kg (27lbs)	R410A x 11.8kg (27lbs)	R410A x 11.8kg (27lbs)		
Net weight	kg (lbs)	270(596)	270(596)	320(706)		
Heat exchanger	Salt-resistant cross fin & copper tube					
Optional parts	Joint: CMY-Y102SS-G2, CMY-Y102LS-G2, CMY-R160-J1 BC controller: CMB-P104, 105, 106, 108, 1010, 1013, 1016V-GA1 Main BC controller: CMB-P108, 1010, 1013, 1016V-GA1 Sub BC controller: CMB-P104, 108V-GB1, CMB-P1016V-HB1 Joint: CMY-Y102SS-G2, CMY-Y102LS-G2, CMY-R160-J1 Main BC controller: CMB-P108, 1010, 1013, 1016V-GA1 Sub BC controller: CMB-P104, 108V-GB1, CMB-P1016V-HB1 Joint: CMY-Y102SS-G2, CMY-Y102LS-G2, CMY-R160-J1 Main BC controller: CMB-P108, 1010, 1013, 1016V-GA1 Sub BC controller: CMB-P104, 108V-GB1, CMB-P1016V-HB1					

### Notes:

\*1, \*2 Nominal conditions

	Indoor	Outdoor	Pipe length	Level difference
Cooling	27°C DB/19°C WB (81°F DB/66°F WB)	35°C DB(95°F DB)	7.5m (24-9/16ft.)	0m (0ft.)
Heating	20°C DB(68°F DB)	7°C DB/6°C WB(45°F DB/43°F WB)	7.5m (24-9/16ft.)	0m (0ft.)

\*3 -5°C DB (23°F DB) / -6°C WB (21°F WB) to 21°C DB (70°F DB) / 15.5°C WB (60°F WB) with cooling/heating mixed operation.

\*4 External static pressure option is available (30Pa, 60Pa / 3.1mmH<sub>2</sub>O, 6.1mmH<sub>2</sub>O).

\*Nominal condition \*1, \*2 are subject to JIS B8615-1.

\*Due to continuing improvement, above specification may be subject to change without notice.

# OUTDOOR UNIT R2 Series PURY-P YSJM-A(1)(-BS)



## ► Specifications

Model	PURY-P400YSJM-A1(-BS)		PURY-P450YSJM-A1(-BS)		PURY-P500YSJM-A(-BS)		
Power source	3-phase 4-wire 380-400-415V 50/60Hz						
Cooling capacity (Nominal)	*1 kW	45.0	50.0	56.0			
	*1 BTU/h	153,500	170,600	191,100			
	Power input kW	10.73	12.50	14.85			
	Current input A	18.1-17.2-16.5	21.1-20.0-19.3	25.0-23.8-22.9			
	COP kW/kW	4.19	4.00	3.77			
Temp. range of cooling *3	Indoor W.B.	15.0~24.0°C(59~75°F)	15.0~24.0°C(59~75°F)	15.0~24.0°C(59~75°F)			
	Outdoor D.B.	-5.0~46.0°C(23~115°F)	-5.0~46.0°C(23~115°F)	-5.0~46.0°C(23~115°F)			
Heating capacity (Nominal)	*2 kW	50.0	56.0	63.0			
	*2 BTU/h	170,600	191,100	215,000			
	Power input kW	11.62	13.30	15.10			
	Current input A	19.6-18.6-17.9	22.4-21.3-20.5	25.4-24.2-23.3			
	COP kW/kW	4.30	4.21	4.17			
Temp. range of heating *3	Indoor W.B.	15.0~27.0°C(59~81°F)	15.0~27.0°C(59~81°F)	15.0~27.0°C(59~81°F)			
	Outdoor W.B.	-20.0~15.5°C(-4~60°F)	-20.0~15.5°C(-4~60°F)	-20.0~15.5°C(-4~60°F)			
Indoor unit connectable	Total capacity	50~150 % of outdoor unit capacity	50~150 % of outdoor unit capacity	50~150 % of outdoor unit capacity			
Sound pressure level (measured in anechoic room)	dB <A>	59	59.5	60			
Power pressure level (measured in anechoic room)	dB <A>	79	79.5	80			
Refrigerant piping diameter	High pressure mm (in.)	22.2(7/8) Braze	22.2(7/8) Braze	22.2(7/8) Braze			
	Low pressure mm (in.)	28.58(1-1/8) Braze	28.58(1-1/8) Braze	28.58(1-1/8) Braze			
<b>Set Model</b>							
Model	PURY-P200YJM-A(-BS)	PURY-P200YJM-A(-BS)	PURY-P200YJM-A(-BS)	PURY-P250YJM-A(-BS)	PURY-P250YJM-A(-BS)	PURY-P250YJM-A(-BS)	
FAN	Type x Quantity	Propeller fan x 1	Propeller fan x 1	Propeller fan x 1	Propeller fan x 1	Propeller fan x 1	
	Air flow rate	m³/min	185	185	185	185	185
		L/s	3,083	3,083	3,083	3,083	3,083
		cfm	6,532	6,532	6,532	6,532	6,532
	Driving mechanism	Inverter-control, Direct-driven by motor					
	Motor output kW	0.92 x 1		0.92 x 1		0.92 x 1	
	*4 External static press.	0 Pa (0 mmH <sub>2</sub> O)		0 Pa (0 mmH <sub>2</sub> O)		0 Pa (0 mmH <sub>2</sub> O)	
	Type x Quantity	Inverter scroll hermetic compressor					
	Starting method	Inverter					
	Motor output kW	5.4		5.4		6.8	
Case heater kW	0.035(240 V)		0.035(240 V)		0.035(240 V)		
External finish	Pre-coated galvanized steel sheets (+powder coating for -BS type) <MUNSELL 5Y 8/1 or similar>						
External dimension HxWxD	mm	1,710(1,650 without legs) x 920 x 760	1,710(1,650 without legs) x 920 x 760	1,710(1,650 without legs) x 920 x 760	1,710(1,650 without legs) x 920 x 760	1,710(1,650 without legs) x 920 x 760	
	in.	67-3/8(65 without legs) x 36-1/4 x 29-15/16	67-3/8(65 without legs) x 36-1/4 x 29-15/16	67-3/8(65 without legs) x 36-1/4 x 29-15/16	67-3/8(65 without legs) x 36-1/4 x 29-15/16	67-3/8(65 without legs) x 36-1/4 x 29-15/16	
Protection devices	High pressure protection	High pressure sensor, High pressure switch at 4.15MPa (601 psi)		High pressure sensor, High pressure switch at 4.15MPa (601 psi)		High pressure sensor, High pressure switch at 4.15MPa (601 psi)	
	Inverter circuit (COMP./FAN)	Over-heat protection, Over-current protection		Over-heat protection, Over-current protection		Over-heat protection, Over-current protection	
	Compressor	Over-heat protection		Over-heat protection		Over-heat protection	
	Fan motor	Thermal switch		Thermal switch		Thermal switch	
Refrigerant	Type x original charge	R410A x 9.5kg (21lbs)	R410A x 9.5kg (21lbs)	R410A x 9.5kg (21lbs)	R410A x 9.5kg (21lbs)	R410A x 9.5kg (21lbs)	
Net weight	kg (lbs)	240(530)	240(530)	240(530)	240(530)	240(530)	
Heat exchanger	Salt-resistant cross fin & copper tube						
Pipe between unit and distributor	High pressure mm (in.)	15.88(5/8) Braze	15.88(5/8) Braze	15.88(5/8) Braze	19.05(3/4) Braze	19.05(3/4) Braze	
	Low pressure mm (in.)	19.05(3/4) Braze	-	19.05(3/4) Braze	-	22.2(7/8) Braze	
Optional parts	Outdoor Twinning kit: CMY-R100VBK Joint: CMY-Y102SS-G2, CMY-Y102LS-G2, CMY-R160-J1 Main BC controller: CMB-P108, 1010, 1013, 1016V-GA1 Sub BC controller: CMB-P104, 108V-GB1, CMB-P1016V-HB1 Outdoor Twinning kit: CMY-R100VBK Joint: CMY-Y102SS-G2, CMY-Y102LS-G2, CMY-R160-J1 Main BC controller: CMB-P108, 1010, 1013, 1016V-GA1 Sub BC controller: CMB-P104, 108V-GB1, CMB-P1016V-HB1 Outdoor Twinning kit: CMY-R100VBK Joint: CMY-Y102SS-G2, CMY-Y102LS-G2, CMY-R160-J1 Main BC controller: CMB-P108, 1010, 1013, 1016V-GA1 Sub BC controller: CMB-P104, 108V-GB1, CMB-P1016V-HB1						

### Notes:

\*1, \*2 Nominal conditions

	Indoor	Outdoor	Pipe length	Level difference
Cooling	27°C DB/19°C WB (81°F DB/66°F WB)	35°C DB(95°F DB)	7.5m (24-9/16ft.)	0m (0ft.)
Heating	20°C DB(68°F DB)	7°C DB/6°C WB(45°F DB/43°F WB)	7.5m (24-9/16ft.)	0m (0ft.)

\*3 -5°C DB (23°F DB) / -6°C WB (21°F WB) to 21°C DB (70°F DB) / 15.5°C WB (60°F WB) with cooling/heating mixed operation.

\*4 External static pressure option is available (30Pa, 60Pa / 3.1mmH<sub>2</sub>O, 6.1mmH<sub>2</sub>O).

\*Nominal condition \*1, \*2 are subject to JIS B8615-1.

\*Due to continuing improvement, above specification may be subject to change without notice.

# OUTDOOR UNIT R2 Series PURY-P YSJM-A(1)(-BS)



## ► Specifications

Model	PURY-P500YSJM-A1(-BS)		PURY-P550YSJM-A(-BS)		PURY-P600YSJM-A(-BS)					
Power source	3-phase 4-wire 380-400-415V 50/60Hz									
Cooling capacity (Nominal)	*1 kW	56.0		63.0		69.0				
	*1 BTU / h	191,100		215,000		235,400				
	Power input kW	14.73		17.30		19.65				
	Current input A	24.8-23.6-22.7		29.2-27.7-26.7		33.1-31.5-30.3				
	COP	3.80		3.64		3.51				
Temp. range of cooling	*3 Indoor	W.B. 15.0~24.0°C(59~75°F)		15.0~24.0°C(59~75°F)		15.0~24.0°C(59~75°F)				
	*3 Outdoor	D.B. -5.0~46.0°C(23~115°F)		-5.0~46.0°C(23~115°F)		-5.0~46.0°C(23~115°F)				
Heating capacity (Nominal)	*2 kW	63.0		69.0		76.5				
	*2 BTU / h	215,000		235,400		261,000				
	Power input kW	15.07		16.95		19.07				
	Current input A	25.4-24.1-23.2		28.6-27.1-26.2		32.1-30.5-29.4				
	COP	4.18		4.07		4.01				
Temp. range of heating	*3 Indoor	W.B. 15.0~27.0°C(59~81°F)		15.0~27.0°C(59~81°F)		15.0~27.0°C(59~81°F)				
	*3 Outdoor	W.B. -20.0~15.5°C(-4~60°F)		-20.0~15.5°C(-4~60°F)		-20.0~15.5°C(-4~60°F)				
Indoor unit connectable	Total capacity 50~150 % of outdoor unit capacity		50~150 % of outdoor unit capacity		50~150 % of outdoor unit capacity					
Sound pressure level (measured in anechoic room)	dB <A>	61		61		62				
Power pressure level (measured in anechoic room)	dB <A>	81		81		82				
Refrigerant piping diameter	High pressure	mm (in.) 22.2(7/8) Braze		28.58(1-1/8) Braze		28.58(1-1/8) Braze				
	Low pressure	mm (in.) 28.58(1-1/8) Braze		28.58(1-1/8) Braze		28.58(1-1/8) Braze				
<b>Set Model</b>										
Model	PURY-P200YJM-A(-BS)		PURY-P300YJM-A(-BS)		PURY-P300YJM-A(-BS)		PURY-P300YJM-A(-BS)			
FAN	Type x Quantity	Propeller fan x 1		Propeller fan x 1		Propeller fan x 1		Propeller fan x 1		
	Air flow rate	m³/min	185		185		185		185	
		L/s	3,083		3,083		3,083		3,083	
		cfm	6,532		6,532		6,532		6,532	
	Driving mechanism	Inverter-control, Direct-driven by motor		Inverter-control, Direct-driven by motor		Inverter-control, Direct-driven by motor		Inverter-control, Direct-driven by motor		
*4 External static press.	0 Pa (0 mmH <sub>2</sub> O)		0 Pa (0 mmH <sub>2</sub> O)		0 Pa (0 mmH <sub>2</sub> O)		0 Pa (0 mmH <sub>2</sub> O)			
Compressor	Type x Quantity	Inverter scroll hermetic compressor		Inverter scroll hermetic compressor		Inverter scroll hermetic compressor		Inverter scroll hermetic compressor		
	Starting method	Inverter		Inverter		Inverter		Inverter		
	Motor output kW	5.4		7.8		7.8		7.8		
Case heater	kW 0.035(240 V)		0.045(240 V)		0.035(240 V)		0.045(240 V)			
External finish	Pre-coated galvanized steel sheets (+powder coating for -BS type) <MUNSELL 5Y 8/1 or similar>									
External dimension HxWxD	mm	1,710(1,650 without legs) x 920 x 760		1,710(1,650 without legs) x 920 x 760		1,710(1,650 without legs) x 920 x 760		1,710(1,650 without legs) x 920 x 760		
	in.	67-3/8(65 without legs) x 36-1/4 x 29-15/16		67-3/8(65 without legs) x 36-1/4 x 29-15/16		67-3/8(65 without legs) x 36-1/4 x 29-15/16		67-3/8(65 without legs) x 36-1/4 x 29-15/16		
Protection devices	High pressure protection	High pressure sensor, High pressure switch at 4.15MPa (601 psi)		High pressure sensor, High pressure switch at 4.15MPa (601 psi)		High pressure sensor, High pressure switch at 4.15MPa (601 psi)		High pressure sensor, High pressure switch at 4.15MPa (601 psi)		
	Inverter circuit (COMP./FAN)	Over-heat protection, Over-current protection		Over-heat protection, Over-current protection		Over-heat protection, Over-current protection		Over-heat protection, Over-current protection		
	Compressor	Over-heat protection		Over-heat protection		Over-heat protection		Over-heat protection		
	Fan motor	Thermal switch		Thermal switch		Thermal switch		Thermal switch		
Refrigerant	Type x original charge	R410A x 9.5kg (21lbs)		R410A x 9.5kg (21lbs)		R410A x 9.5kg (21lbs)		R410A x 9.5kg (21lbs)		
Net weight	kg (lbs)	240(530)		245(541)		245(541)		245(541)		
Heat exchanger	Salt-resistant cross fin & copper tube									
Pipe between unit and distributor	High pressure	mm (in.) 15.88(5/8) Braze		19.05(3/4) Braze		19.05(3/4) Braze		19.05(3/4) Braze		
	Low pressure	mm (in.) 19.05(3/4) Braze		22.2(7/8) Braze		22.2(7/8) Braze		22.2(7/8) Braze		
Optional parts	Outdoor Twinning kit: CMY-R100VBK Joint: CMY-Y102SS-G2, CMY-Y102LS-G2, CMY-R160-J1 Main BC controller: CMB-P108, 1010, 1013, 1016V-GA1 Sub BC controller: CMB-P104, 108V-GB1, CMB-P1016V-HB1									

### Notes:

\*1, \*2 Nominal conditions

	Indoor	Outdoor	Pipe length	Level difference
Cooling	27°C DB/19°C WB (81°F DB/66°F WB)	35°C DB(95°F DB)	7.5m (24-9/16ft.)	0m (0ft.)
Heating	20°C DB(68°F DB)	7°C DB/6°C WB(45°F DB/43°F WB)	7.5m (24-9/16ft.)	0m (0ft.)

\*3 -5°C DB (23°F DB) / -6°C WB (21°F WB) to 21°C DB (70°F DB) / 15.5°C WB (60°F WB) with cooling/heating mixed operation.

\*4 External static pressure option is available (30Pa, 60Pa / 3.1mmH<sub>2</sub>O, 6.1mmH<sub>2</sub>O).

\*Nominal condition \*1, \*2 are subject to JIS B8615-1.

\*Due to continuing improvement, above specification may be subject to change without notice.

Outdoor unit

# OUTDOOR UNIT R2 Series PURY-P YSJM-A(1)(-BS)



## ► Specifications

Model	PURY-P600YSJM-A1(-BS)		PURY-P650YSJM-A(-BS)		PURY-P700YSJM-A(-BS)					
Power source	3-phase 4-wire 380-400-415V 50/60Hz									
Cooling capacity (Nominal)	*1 kW	69.0		73.0		80.0				
	*1 BTU / h	235,400		249,100		273,000				
	Power input kW	19.16		21.53		23.95				
	Current input A	32.3-30.7-29.6		36.3-34.5-33.2		40.4-38.4-37.0				
	COP	3.60		3.39		3.34				
Temp. range of cooling	*3 Indoor	W.B. 15.0~24.0°C(59~75°F)		15.0~24.0°C(59~75°F)		15.0~24.0°C(59~75°F)				
	*3 Outdoor	D.B. -5.0~46.0°C(23~115°F)		-5.0~46.0°C(23~115°F)		-5.0~46.0°C(23~115°F)				
Heating capacity (Nominal)	*2 kW	76.5		81.5		88.0				
	*2 BTU / h	261,000		278,100		300,300				
	Power input kW	18.61		20.47		22.33				
	Current input A	31.4-29.8-28.7		34.5-32.8-31.6		37.6-35.8-34.5				
	COP	4.11		3.98		3.94				
Temp. range of heating	*3 Indoor	W.B. 15.0~27.0°C(59~81°F)		15.0~27.0°C(59~81°F)		15.0~27.0°C(59~81°F)				
	*3 Outdoor	W.B. -20.0~15.5°C(-4~60°F)		-20.0~15.5°C(-4~60°F)		-20.0~15.5°C(-4~60°F)				
Indoor unit connectable	Total capacity 50~150 % of outdoor unit capacity		50~150 % of outdoor unit capacity		50~150 % of outdoor unit capacity					
Sound pressure level (measured in anechoic room)	dB <A>	62		62.5		63				
Power pressure level (measured in anechoic room)	dB <A>	82		82.5		83				
Refrigerant piping diameter	High pressure	mm (in.) 28.58(1-1/8) Braze		28.58(1-1/8) Braze		28.58(1-1/8) Braze				
	Low pressure	mm (in.) 28.58(1-1/8) Braze		28.58(1-1/8) Braze		34.93(1-3/8) Braze				
<b>Set Model</b>										
Model	PURY-P250YJM-A(-BS)		PURY-P350YJM-A(-BS)		PURY-P350YJM-A(-BS)		PURY-P400YJM-A(-BS)			
FAN	Type x Quantity	Propeller fan x 1		Propeller fan x 1		Propeller fan x 1		Propeller fan x 1		
	Air flow rate	m³/min	185		225		185		225	
		L/s	3,083		3,750		3,083		3,750	
		cfm	6,532		7,945		6,532		7,945	
	Driving mechanism	Inverter-control, Direct-driven by motor		Inverter-control, Direct-driven by motor		Inverter-control, Direct-driven by motor		Inverter-control, Direct-driven by motor		
*4 External static press.	0 Pa (0 mmH <sub>2</sub> O)		0 Pa (0 mmH <sub>2</sub> O)		0 Pa (0 mmH <sub>2</sub> O)		0 Pa (0 mmH <sub>2</sub> O)			
Compressor	Type x Quantity	Inverter scroll hermetic compressor		Inverter scroll hermetic compressor		Inverter scroll hermetic compressor		Inverter scroll hermetic compressor		
	Starting method	Inverter		Inverter		Inverter		Inverter		
	Motor output kW	6.8		9.9		7.8		10.2		
Case heater	kW 0.035(240 V)		0.045(240 V)		0.045(240 V)		0.045(240 V)			
External finish	Pre-coated galvanized steel sheets (+powder coating for -BS type) <MUNSELL 5Y 8/1 or similar>									
External dimension HxWxD	mm	1,710(1,650 without legs) x 920 x 760		1,710(1,650 without legs) x 1,220 x 760		1,710(1,650 without legs) x 920 x 760		1,710(1,650 without legs) x 1,220 x 760		
	in.	67-3/8(65 without legs) x 36-1/4 x 29-15/16		67-3/8(65 without legs) x 48-1/16 x 29-15/16		67-3/8(65 without legs) x 36-1/4 x 29-15/16		67-3/8(65 without legs) x 48-1/16 x 29-15/16		
Protection devices	High pressure protection	High pressure sensor, High pressure switch at 4.15MPa (601 psi)		High pressure sensor, High pressure switch at 4.15MPa (601 psi)		High pressure sensor, High pressure switch at 4.15MPa (601 psi)		High pressure sensor, High pressure switch at 4.15MPa (601 psi)		
	Inverter circuit (COMP./FAN)	Over-heat protection, Over-current protection		Over-heat protection, Over-current protection		Over-heat protection, Over-current protection		Over-heat protection, Over-current protection		
	Compressor	Over-heat protection		Over-heat protection		Over-heat protection		Over-heat protection		
	Fan motor	Thermal switch		Thermal switch		Thermal switch		Thermal switch		
Refrigerant	Type x original charge	R410A x 9.5kg (21lbs)		R410A x 11.8kg (27lbs)		R410A x 9.5kg (21lbs)		R410A x 11.8kg (27lbs)		
Net weight	kg (lbs)	240(530)		270(596)		245(541)		270(596)		
Heat exchanger	Salt-resistant cross fin & copper tube									
Pipe between unit and distributor	High pressure	mm (in.) 19.05(3/4) Braze		19.05(3/4) Braze		19.05(3/4) Braze		22.2(7/8) Braze		
	Low pressure	mm (in.) 22.2(7/8) Braze		-		22.2(7/8) Braze		-		
Optional parts	Outdoor Twinning kit: CMY-R100VBK Joint: CMY-Y102SS-G2, CMY-Y102LS-G2, CMY-R160-J1 Main BC controller: CMB-P108, 1010, 1013, 1016V-GA1 Sub BC controller: CMB-P104, 108V-GB1, CMB-P1016V-HB1									

### Notes:

\*1, \*2 Nominal conditions

	Indoor	Outdoor	Pipe length	Level difference
Cooling	27°C DB/19°C WB (81°F DB/66°F WB)	35°C DB(95°F DB)	7.5m (24-9/16ft.)	0m (0ft.)
Heating	20°C DB(68°F DB)	7°C DB/6°C WB(45°F DB/43°F WB)	7.5m (24-9/16ft.)	0m (0ft.)

\*3 -5°C DB (23°F DB) / -6°C WB (21°F WB) to 21°C DB (70°F DB) / 15.5°C WB (60°F WB) with cooling/heating mixed operation.

\*4 External static pressure option is available (30Pa, 60Pa / 3.1mmH<sub>2</sub>O, 6.1mmH<sub>2</sub>O).

\*Nominal condition \*1, \*2 are subject to JIS B8615-1.

\*Due to continuing improvement, above specification may be subject to change without notice.

Outdoor Unit

# OUTDOOR UNIT R2 Series PURY-P YSJM-A(1)(-BS)



## ► Specifications

Model	PURY-P700YSJM-A1(-BS)		PURY-P750YSJM-A(-BS)		PURY-P800YSJM-A(-BS)	
Power source	3-phase 4-wire 380-400-415V 50/60Hz					
Cooling capacity (Nominal)	*1 kW	80.0	85.0	90.0		
	*1 BTU/h	273,000	290,000	307,100		
	Power input kW	23.39	26.47	28.30		
	Current input A	39.4-37.5-36.1	44.6-42.4-40.9	47.7-45.3-43.7		
	COP kW/kW	3.42	3.21	3.18		
Temp. range of cooling *3	Indoor W.B.	15.0~24.0°C(59~75°F)	15.0~24.0°C(59~75°F)	15.0~24.0°C(59~75°F)		
	Outdoor D.B.	-5.0~46.0°C(23~115°F)	-5.0~46.0°C(23~115°F)	-5.0~46.0°C(23~115°F)		
Heating capacity (Nominal)	*2 kW	88.0	95.0	100.0		
	*2 BTU/h	300,300	324,100	341,200		
	Power input kW	21.78	24.05	26.04		
	Current input A	36.7-34.9-33.6	40.6-38.5-37.1	43.9-41.7-40.2		
	COP kW/kW	4.04	3.95	3.84		
Temp. range of heating *3	Indoor W.B.	15.0~27.0°C(59~81°F)	15.0~27.0°C(59~81°F)	15.0~27.0°C(59~81°F)		
	Outdoor W.B.	-20.0~15.5°C(-4~60°F)	-20.0~15.5°C(-4~60°F)	-20.0~15.5°C(-4~60°F)		
Indoor unit connectable	50~150 % of outdoor unit capacity					
Sound pressure level (measured in anechoic room)	dB <A>	63	63.5	64		
Power pressure level (measured in anechoic room)	dB <A>	83	83.5	84		
Refrigerant piping diameter	High pressure mm (in.)	28.58(1-1/8) Braze	28.58(1-1/8) Braze	28.58(1-1/8) Braze		
	Low pressure mm (in.)	34.93(1-3/8) Braze	34.93(1-3/8) Braze	34.93(1-3/8) Braze		

Set Model	PURY-P350YJM-A(-BS)		PURY-P400YJM-A(-BS)		PURY-P450YJM-A(-BS)		PURY-P500YJM-A(-BS)		
FAN	Type x Quantity	Propeller fan x 1		Propeller fan x 1		Propeller fan x 1		Propeller fan x 1	
	Air flow rate	m³/min	225	225	225	225	225	225	225
		L/s	3,750	3,750	3,750	3,750	3,750	3,750	3,750
		cfm	7,945	7,945	7,945	7,945	7,945	7,945	7,945
	Driving mechanism	Inverter-control, Direct-driven by motor							
*4 External static press.	0 Pa (0 mmH <sub>2</sub> O)		0 Pa (0 mmH <sub>2</sub> O)		0 Pa (0 mmH <sub>2</sub> O)		0 Pa (0 mmH <sub>2</sub> O)		
Compressor	Type x Quantity	Inverter scroll hermetic compressor		Inverter scroll hermetic compressor		Inverter scroll hermetic compressor		Inverter scroll hermetic compressor	
	Starting method	Inverter		Inverter		Inverter		Inverter	
	Motor output kW	9.9	9.9	9.9	10.2	10.2	10.2	10.2	
	Case heater kW	0.045(240 V)	0.045(240 V)	0.045(240 V)	0.045(240 V)	0.045(240 V)	0.045(240 V)	0.045(240 V)	
External finish	Pre-coated galvanized steel sheets (+powder coating for -BS type) <MUNSELL 5Y 8/1 or similar>								
External dimension HxWxD	mm	1,710(1,650 without legs) x 1,220 x 760	1,710(1,650 without legs) x 1,220 x 760	1,710(1,650 without legs) x 1,220 x 760	1,710(1,650 without legs) x 1,220 x 760	1,710(1,650 without legs) x 1,220 x 760	1,710(1,650 without legs) x 1,220 x 760	1,710(1,650 without legs) x 1,220 x 760	
	in.	67-3/8(65 without legs) x 48-1/16 x 29-15/16	67-3/8(65 without legs) x 48-1/16 x 29-15/16	67-3/8(65 without legs) x 48-1/16 x 29-15/16	67-3/8(65 without legs) x 48-1/16 x 29-15/16	67-3/8(65 without legs) x 48-1/16 x 29-15/16	67-3/8(65 without legs) x 48-1/16 x 29-15/16	67-3/8(65 without legs) x 48-1/16 x 29-15/16	
Protection devices	High pressure protection	High pressure sensor, High pressure switch at 4.15MPa (601 psi)		High pressure sensor, High pressure switch at 4.15MPa (601 psi)		High pressure sensor, High pressure switch at 4.15MPa (601 psi)		High pressure sensor, High pressure switch at 4.15MPa (601 psi)	
	Inverter circuit (COMP./FAN)	Over-heat protection, Over-current protection		Over-heat protection, Over-current protection		Over-heat protection, Over-current protection		Over-heat protection, Over-current protection	
	Compressor	Over-heat protection		Over-heat protection		Over-heat protection		Over-heat protection	
	Fan motor	Thermal switch		Thermal switch		Thermal switch		Thermal switch	
Refrigerant	Type x original charge	R410A x 11.8kg (27lbs)	R410A x 11.8kg (27lbs)	R410A x 11.8kg (27lbs)	R410A x 11.8kg (27lbs)	R410A x 11.8kg (27lbs)	R410A x 11.8kg (27lbs)	R410A x 11.8kg (27lbs)	
Net weight	kg (lbs)	270(596)	270(596)	270(596)	270(596)	270(596)	270(596)	270(596)	
Heat exchanger	Salt-resistant cross fin & copper tube								
Pipe between unit and distributor	High pressure mm (in.)	19.05(3/4) Braze	19.05(3/4) Braze	19.05(3/4) Braze	22.2(7/8) Braze	22.2(7/8) Braze	22.2(7/8) Braze	22.2(7/8) Braze	
	Low pressure mm (in.)	28.58(1-1/8) Braze	28.58(1-1/8) Braze	28.58(1-1/8) Braze	28.58(1-1/8) Braze	28.58(1-1/8) Braze	28.58(1-1/8) Braze	28.58(1-1/8) Braze	
Optional parts	Outdoor Twinning kit: CMY-R200VBK Joint: CMY-Y102SS-G2, CMY-Y102LS-G2, CMY-R160-J1 Main BC controller: CMB-P1016V-HA1 Sub BC controller: CMB-P104, 108V-GB1, CMB-P1016V-HB1								

### Notes:

\*1, \*2 Nominal conditions

	Indoor	Outdoor	Pipe length	Level difference
Cooling	27°C DB/19°C WB (81°F DB/66°F WB)	35°C DB(95°F DB)	7.5m (24-9/16ft.)	0m (0ft.)
Heating	20°C DB(68°F DB)	7°C DB/6°C WB(45°F DB/43°F WB)	7.5m (24-9/16ft.)	0m (0ft.)

\*3 -5°C DB (23°F DB) / -6°C WB (21°F WB) to 21°C DB (70°F DB) / 15.5°C WB (60°F WB) with cooling/heating mixed operation.

\*4 External static pressure option is available (30Pa, 60Pa / 3.1mmH<sub>2</sub>O, 6.1mmH<sub>2</sub>O).

\*Nominal condition \*1, \*2 are subject to JIS B8615-1.

\*Due to continuing improvement, above specification may be subject to change without notice.

Outdoor unit

# OUTDOOR UNIT R2 Series PURY-P YSJM-A(1)(-BS)



## ► Specifications

Model	PURY-P800YSJM-A1(-BS)		PURY-P850YSJM-A(-BS)		PURY-P900YSJM-A(-BS)	
Power source	3-phase 4-wire 380-400-415V 50/60Hz					
Cooling capacity (Nominal)	*1 kW	90.0	96.0	101.0		
	*1 BTU/h	307,100	327,600	344,600		
	Power input kW	26.62	29.26	30.23		
	Current input A	44.9-42.6-41.1	49.3-46.9-45.2	51.0-48.4-46.7		
	COP kW/kW	3.38	3.28	3.34		
Temp. range of cooling *3	Indoor W.B.	15.0~24.0°C(59~75°F)	15.0~24.0°C(59~75°F)	15.0~24.0°C(59~75°F)		
	Outdoor D.B.	-5.0~46.0°C(23~115°F)	-5.0~46.0°C(23~115°F)	-5.0~46.0°C(23~115°F)		
Heating capacity (Nominal)	*2 kW	108.0	113.0	118.0		
	*2 BTU/h	341,200	368,500	385,600		
	Power input kW	25.77	28.42	30.05		
	Current input A	43.5-41.3-39.8	47.9-45.5-43.9	50.7-48.1-46.4		
	COP kW/kW	3.88	3.80	3.76		
Temp. range of heating *3	Indoor D.B.	15.0~27.0°C(59~81°F)	15.0~27.0°C(59~81°F)	15.0~27.0°C(59~81°F)		
	Outdoor W.B.	-20.0~15.5°C(-4~60°F)	-20.0~15.5°C(-4~60°F)	-20.0~15.5°C(-4~60°F)		
Indoor unit connectable	50~150 % of outdoor unit capacity					
Sound pressure level (measured in anechoic room)	dB <A>	64	64.5	65		
Power pressure level (measured in anechoic room)	dB <A>	84	84.5	85		
Refrigerant piping diameter	High pressure mm (in.)	28.58(1-1/8) Braze	28.58(1-1/8) Braze	28.58(1-1/8) Braze		
	Low pressure mm (in.)	34.93(1-3/8) Braze	41.28(1-5/8) Braze	41.28(1-5/8) Braze		

Set Model	PURY-P350YJM-A(-BS)		PURY-P400YJM-A(-BS)		PURY-P450YJM-A(-BS)		PURY-P500YJM-A(-BS)		
FAN	Type x Quantity	Propeller fan x 1		Propeller fan x 2		Propeller fan x 1		Propeller fan x 2	
	Air flow rate	m³/min	225	360	225	360	225	360	225
		L/s	3,750	6,000	3,750	6,000	3,750	6,000	3,750
		cfm	7,945	12,712	7,945	12,712	7,945	12,712	7,945
	Driving mechanism	Inverter-control, Direct-driven by motor							
*4 External static press.	0 Pa (0 mmH <sub>2</sub> O)		0 Pa (0 mmH <sub>2</sub> O)		0 Pa (0 mmH <sub>2</sub> O)		0 Pa (0 mmH <sub>2</sub> O)		
Compressor	Type x Quantity	Inverter scroll hermetic compressor		Inverter scroll hermetic compressor		Inverter scroll hermetic compressor		Inverter scroll hermetic compressor	
	Starting method	Inverter		Inverter		Inverter		Inverter	
	Motor output kW	9.9	11.6	10.2	11.6	11.6	11.6	11.6	
	Case heater kW	0.045(240 V)	0.045(240 V)	0.045(240 V)	0.045(240 V)	0.045(240 V)	0.045(240 V)	0.045(240 V)	
External finish	Pre-coated galvanized steel sheets (+powder coating for -BS type) <MUNSELL 5Y 8/1 or similar>								
External dimension HxWxD	mm	1,710(1,650 without legs) x 1,220 x 760	1,710(1,650 without legs) x 1,750 x 760	1,710(1,650 without legs) x 1,220 x 760	1,710(1,650 without legs) x 1,750 x 760	1,710(1,650 without legs) x 1,220 x 760	1,710(1,650 without legs) x 1,750 x 760	1,710(1,650 without legs) x 1,220 x 760	
	in.	67-3/8(65 without legs) x 48-1/16 x 29-15/16	67-3/8(65 without legs) x 68-15/16 x 29-15/16	67-3/8(65 without legs) x 48-1/16 x 29-15/16	67-3/8(65 without legs) x 68-15/16 x 29-15/16	67-3/8(65 without legs) x 48-1/16 x 29-15/16	67-3/8(65 without legs) x 68-15/16 x 29-15/16	67-3/8(65 without legs) x 68-15/16 x 29-15/16	
Protection devices	High pressure protection	High pressure sensor, High pressure switch at 4.15MPa (601 psi)		High pressure sensor, High pressure switch at 4.15MPa (601 psi)		High pressure sensor, High pressure switch at 4.15MPa (601 psi)		High pressure sensor, High pressure switch at 4.15MPa (601 psi)	
	Inverter circuit (COMP./FAN)	Over-heat protection, Over-current protection		Over-heat protection, Over-current protection		Over-heat protection, Over-current protection		Over-heat protection, Over-current protection	
	Compressor	Over-heat protection		Over-heat protection		Over-heat protection		Over-heat protection	
	Fan motor	Thermal switch		Thermal switch		Thermal switch		Thermal switch	
Refrigerant	Type x original charge	R410A x 11.8kg (27lbs)	R410A x 11.8kg (27lbs)	R410A x 11.8kg (27lbs)	R410A x 11.8kg (27lbs)	R410A x 11.8kg (27lbs)	R410A x 11.8kg (27lbs)	R410A x 11.8kg (27lbs)	
Net weight	kg (lbs)	270(596)	320(706)	270(596)	320(706)	270(596)	320(706)	270(596)	
Heat exchanger	Salt-resistant cross fin & copper tube								
Pipe between unit and distributor	High pressure mm (in.)	19.05(3/4) Braze	22.2(7/8) Braze	19.05(3/4) Braze	22.2(7/8) Braze	19.05(3/4) Braze	22.2(7/8) Braze	19.05(3/4) Braze	
	Low pressure mm (in.)	28.58(1-1/8) Braze	28.58(1-1/8) Braze	28.58(1-1/8) Braze	28.58(1-1/8) Braze	28.58(1-1/8) Braze	28.58(1-1/8) Braze	28.58(1-1/8) Braze	
Optional parts	Outdoor Twinning kit: CMY-R100LVBK Joint: CMY-Y102SS-G2, CMY-Y102LS-G2, CMY-R160-J1 Main BC controller: CMB-P1016V-HA1 Sub BC controller: CMB-P104, 108V-GB1, CMB-P1016V-HB1								

### Notes:

\*1, \*2 Nominal conditions

	Indoor	Outdoor	Pipe length	Level difference
Cooling	27°C DB/19°C WB (81°F DB/66°F WB)	35°C DB(95°F DB)	7.5m (24-9/16ft.)	0m (0ft.)
Heating	20°C DB(68°F DB)	7°C DB/6°C WB(45°F DB/43°F WB)	7.5m (24-9/16ft.)	0m (0ft.)

\*3 -5°C DB (23°F DB) / -6°C WB (21°F WB) to 21°C DB (70°F DB) / 15.5°C WB (60°F WB) with cooling/heating mixed operation.

\*4 External static pressure option is available (30Pa, 60Pa / 3.1mmH<sub>2</sub>O, 6.1mmH<sub>2</sub>O).

\*Nominal condition \*1, \*2 are subject to JIS B8615-1.

\*Due to continuing improvement, above specification may be subject to change without notice.

Outdoor Unit

# OUTDOOR UNIT R2 Series - High COP PURY-EP YJM-A(-BS)



## ► Specifications

Model		PURY-EP200YJM-A(-BS)	PURY-EP250YJM-A(-BS)	PURY-EP300YJM-A(-BS)	PURY-EP350YJM-A(-BS)	
Power source		3-phase 4-wire 380-400-415V 50/60Hz	3-phase 4-wire 380-400-415V 50/60Hz	3-phase 4-wire 380-400-415V 50/60Hz	3-phase 4-wire 380-400-415V 50/60Hz	
Cooling capacity (Nominal)	*1 kW	22.4	28.0	33.5	40.0	
	*1 BTU/h	76,400	95,500	114,300	136,500	
	Power input kW	5.07	6.76	8.25	10.28	
	Current input A	8.5-8.1-7.8	11.4-10.8-10.4	13.9-13.2-12.7	17.3-16.4-15.8	
COP	kW/kW	4.41	4.14	4.06	3.89	
	Indoor W.B.	15.0~24.0°C(59~75°F)	15.0~24.0°C(59~75°F)	15.0~24.0°C(59~75°F)	15.0~24.0°C(59~75°F)	
	Outdoor D.B.	-5.0~46.0°C(23~115°F)	-5.0~46.0°C(23~115°F)	-5.0~46.0°C(23~115°F)	-5.0~46.0°C(23~115°F)	
Heating capacity (Nominal)	*2 kW	25.0	31.5	37.5	45.0	
	*2 BTU/h	85,300	107,500	128,000	153,500	
	Power input kW	5.56	7.15	8.60	10.58	
	Current input A	9.3-8.9-8.5	12.0-11.4-11.0	14.5-13.7-13.2	17.8-16.9-16.3	
COP	kW/kW	4.49	4.40	4.36	4.25	
	Indoor W.B.	15.0~27.0°C(59~81°F)	15.0~27.0°C(59~81°F)	15.0~27.0°C(59~81°F)	15.0~27.0°C(59~81°F)	
	Outdoor W.B.	-20.0~15.5°C(-4~60°F)	-20.0~15.5°C(-4~60°F)	-20.0~15.5°C(-4~60°F)	-20.0~15.5°C(-4~60°F)	
Indoor unit connectable	Total capacity	50~150 % of outdoor unit capacity	50~150 % of outdoor unit capacity	50~150 % of outdoor unit capacity	50~150 % of outdoor unit capacity	
	Model / Quantity	P15~P250 / 1~20	P15~P250 / 1~25	P15~P250 / 1~30	P15~P250 / 1~35	
Sound pressure level (measured in anechoic room)	dB <A>	57	60	60	61	
Power pressure level (measured in anechoic room)	dB <A>	77	80	80	81	
Refrigerant piping diameter	High pressure mm (in.)	15.88(5/8) Braze	19.05(3/4) Braze	19.05(3/4) Braze	19.05(3/4) Braze	
	Low pressure mm (in.)	19.05(3/4) Braze	22.2(7/8) Braze	22.2(7/8) Braze	28.58(1-1/8) Braze	
FAN	Type x Quantity	Propeller fan x 1	Propeller fan x 1	Propeller fan x 1	Propeller fan x 2	
	Air flow rate	m³/min	185	225	225	360
		L/s	3,083	3,750	3,750	6,000
		cfm	6,532	7,945	7,945	12,712
	Driving mechanism	Inverter-control, Direct-driven by motor	Inverter-control, Direct-driven by motor	Inverter-control, Direct-driven by motor	Inverter-control, Direct-driven by motor	
	Motor output kW	0.92 x 1	0.92 x 1	0.92 x 1	0.92 x 2	
	*4 External static press.	0 Pa (0 mmH₂O)	0 Pa (0 mmH₂O)	0 Pa (0 mmH₂O)	0 Pa (0 mmH₂O)	
	Compressor	Type x Quantity	Inverter scroll hermetic compressor	Inverter scroll hermetic compressor	Inverter scroll hermetic compressor	Inverter scroll hermetic compressor
	Starting method	Inverter	Inverter	Inverter	Inverter	
	Motor output kW	5.4	6.8	7.8	9.9	
Case heater kW	0.035(240 V)	0.045(240 V)	0.045(240 V)	0.045(240 V)		
External finish	Pre-coated galvanized steel sheets (+powder coating for -BS type) <MUNSELL 5Y 8/1 or similar>	Pre-coated galvanized steel sheets (+powder coating for -BS type) <MUNSELL 5Y 8/1 or similar>	Pre-coated galvanized steel sheets (+powder coating for -BS type) <MUNSELL 5Y 8/1 or similar>	Pre-coated galvanized steel sheets (+powder coating for -BS type) <MUNSELL 5Y 8/1 or similar>		
	mm	1,710(1,650 without legs) x 920 x 760	1,710(1,650 without legs) x 1,220 x 760	1,710(1,650 without legs) x 1,220 x 760	1,710(1,650 without legs) x 1,750 x 760	
External dimension HxWxD	in.	67-3/8(65 without legs) x 36-1/4 x 29-15/16	67-3/8(65 without legs) x 48-1/16 x 29-15/16	67-3/8(65 without legs) x 48-1/16 x 29-15/16	67-3/8(65 without legs) x 68-15/16 x 29-15/16	
	Protection devices	High pressure protection	High pressure sensor, High pressure switch at 4.15MPa (601 psi)	High pressure sensor, High pressure switch at 4.15MPa (601 psi)	High pressure sensor, High pressure switch at 4.15MPa (601 psi)	
Compressor	Inverter circuit (COMP./FAN)	Over-heat protection, Over-current protection	Over-heat protection, Over-current protection	Over-heat protection, Over-current protection	Over-heat protection, Over-current protection	
	Compressor	Over-heat protection	Over-heat protection	Over-heat protection	Over-heat protection	
	Fan motor	Thermal switch	Thermal switch	Thermal switch	Thermal switch	
	Refrigerant	Type x original charge	R410A x 9.5kg (21lbs)	R410A x 11.8kg (27lbs)	R410A x 11.8kg (27lbs)	
Net weight	kg (lbs)	240(530)	270(596)	270(596)	320(706)	
Heat exchanger	Salt-resistant cross fin & copper tube	Salt-resistant cross fin & copper tube	Salt-resistant cross fin & copper tube	Salt-resistant cross fin & copper tube		
Optional parts	Joint: CMY-Y102SS-G2, CMY-Y102LS-G2, CMY-R160-J1	Joint: CMY-Y102SS-G2, CMY-Y102LS-G2, CMY-R160-J1	Joint: CMY-Y102SS-G2, CMY-Y102LS-G2, CMY-R160-J1	Joint: CMY-Y102SS-G2, CMY-Y102LS-G2, CMY-R160-J1		
	BC controller: CMB-P104, 105, 106, 108, 1010, 1013, 1016V-G1	BC controller: CMB-P104, 105, 106, 108, 1010, 1013, 1016V-G1	BC controller: CMB-P104, 105, 106, 108, 1010, 1013, 1016V-G1	BC controller: CMB-P104, 105, 106, 108, 1010, 1013, 1016V-G1		
	Main BC controller: CMB-P108, 1010, 1013, 1016V-GA1	Main BC controller: CMB-P108, 1010, 1013, 1016V-GA1	Main BC controller: CMB-P108, 1010, 1013, 1016V-GA1	Main BC controller: CMB-P108, 1010, 1013, 1016V-GA1		
	Sub BC controller: CMB-P104, 108V, GB1, CMB-P1016V-HB1	Sub BC controller: CMB-P104, 108V, GB1, CMB-P1016V-HB1	Sub BC controller: CMB-P104, 108V, GB1, CMB-P1016V-HB1	Sub BC controller: CMB-P104, 108V, GB1, CMB-P1016V-HB1		

### Notes:

\*1, \*2 Nominal conditions

	Indoor	Outdoor	Pipe length	Level difference
Cooling	27°C DB/19°C WB (81°F DB/66°F WB)	35°C DB(95°F DB)	7.5m (24-9/16ft.)	0m (0ft.)
Heating	20°C DB(68°F DB)	7°C DB/6°C WB(45°F DB/43°F WB)	7.5m (24-9/16ft.)	0m (0ft.)

\*3 -5°C DB (23°F DB) / -6°C WB (21°F WB) to 21°C DB (70°F DB) / 15.5°C WB (60°F WB) with cooling/heating mixed operation.

\*4 External static pressure option is available (30Pa, 60Pa / 3.1mmH₂O, 6.1mmH₂O).

\*Nominal condition \*1, \*2 are subject to JIS B8615-1.

\*Due to continuing improvement, above specification may be subject to change without notice.

# OUTDOOR UNIT R2 Series - High COP PURY-EP YSJM-A(-BS)



## ► Specifications

Model		PURY-EP400YSJM-A(-BS)	PURY-EP450YSJM-A(-BS)	PURY-EP500YSJM-A(-BS)			
Power source		3-phase 4-wire 380-400-415V 50/60Hz	3-phase 4-wire 380-400-415V 50/60Hz	3-phase 4-wire 380-400-415V 50/60Hz			
Cooling capacity (Nominal)	*1 kW	45.0	50.0	56.0			
	*1 BTU/h	153,500	170,600	191,100			
	Power input kW	10.41	11.99	13.62			
	Current input A	17.5-16.6-16.0	20.2-19.2-18.5	22.9-21.8-21.0			
COP	kW/kW	4.32	4.17	4.11			
	Indoor W.B.	15.0~24.0°C(59~75°F)	15.0~24.0°C(59~75°F)	15.0~24.0°C(59~75°F)			
	Outdoor D.B.	-5.0~46.0°C(23~115°F)	-5.0~46.0°C(23~115°F)	-5.0~46.0°C(23~115°F)			
Heating capacity (Nominal)	*2 kW	50.0	56.0	63.0			
	*2 BTU/h	170,600	191,100	215,000			
	Power input kW	11.36	12.87	14.38			
	Current input A	19.1-18.2-17.5	21.7-20.6-19.8	24.2-23.0-22.2			
COP	kW/kW	4.40	4.35	4.38			
	Indoor W.B.	15.0~27.0°C(59~81°F)	15.0~27.0°C(59~81°F)	15.0~27.0°C(59~81°F)			
	Outdoor W.B.	-20.0~15.5°C(-4~60°F)	-20.0~15.5°C(-4~60°F)	-20.0~15.5°C(-4~60°F)			
Indoor unit connectable	Total capacity	50~150 % of outdoor unit capacity	50~150 % of outdoor unit capacity	50~150 % of outdoor unit capacity			
	Model / Quantity	P15~P250 / 1~40	P15~P250 / 1~40	P15~P250 / 1~50			
Sound pressure level (measured in anechoic room)	dB <A>	60	62	62			
Power pressure level (measured in anechoic room)	dB <A>	80	82	82			
Refrigerant piping diameter	High pressure mm (in.)	22.2(7/8) Braze	22.2(7/8) Braze	22.2(7/8) Braze			
	Low pressure mm (in.)	28.58(1-1/8) Braze	28.58(1-1/8) Braze	28.58(1-1/8) Braze			
Set Model	FAN	Type x Quantity	Propeller fan x 1	Propeller fan x 1	Propeller fan x 1	Propeller fan x 1	
		Air flow rate	m³/min	185	185	185	225
			L/s	3,083	3,083	3,083	3,750
			cfm	6,532	6,532	6,532	7,945
		Driving mechanism	Inverter-control, Direct-driven by motor	Inverter-control, Direct-driven by motor	Inverter-control, Direct-driven by motor	Inverter-control, Direct-driven by motor	
		Motor output kW	0.92 x 1	0.92 x 1	0.92 x 1	0.92 x 1	
		*4 External static press.	0 Pa (0 mmH₂O)	0 Pa (0 mmH₂O)	0 Pa (0 mmH₂O)	0 Pa (0 mmH₂O)	
		Compressor	Type x Quantity	Inverter scroll hermetic compressor	Inverter scroll hermetic compressor	Inverter scroll hermetic compressor	Inverter scroll hermetic compressor
			Starting method	Inverter	Inverter	Inverter	Inverter
			Motor output kW	5.4	5.4	5.4	6.8
Case heater kW	0.035(240 V)	0.035(240 V)	0.035(240 V)	0.045(240 V)			
External finish	Pre-coated galvanized steel sheets (+powder coating for -BS type) <MUNSELL 5Y 8/1 or similar>	Pre-coated galvanized steel sheets (+powder coating for -BS type) <MUNSELL 5Y 8/1 or similar>	Pre-coated galvanized steel sheets (+powder coating for -BS type) <MUNSELL 5Y 8/1 or similar>	Pre-coated galvanized steel sheets (+powder coating for -BS type) <MUNSELL 5Y 8/1 or similar>			
	mm	1,710(1,650 without legs) x 920 x 760	1,710(1,650 without legs) x 920 x 760	1,710(1,650 without legs) x 1,220 x 760	1,710(1,650 without legs) x 1,750 x 760		
External dimension HxWxD	in.	67-3/8(65 without legs) x 36-1/4 x 29-15/16	67-3/8(65 without legs) x 36-1/4 x 29-15/16	67-3/8(65 without legs) x 48-1/16 x 29-15/16	67-3/8(65 without legs) x 68-15/16 x 29-15/16		
	Protection devices	High pressure protection	High pressure sensor, High pressure switch at 4.15MPa (601 psi)	High pressure sensor, High pressure switch at 4.15MPa (601 psi)	High pressure sensor, High pressure switch at 4.15MPa (601 psi)		
Compressor	Inverter circuit (COMP./FAN)	Over-heat protection, Over-current protection	Over-heat protection, Over-current protection	Over-heat protection, Over-current protection	Over-heat protection, Over-current protection		
	Compressor	Over-heat protection	Over-heat protection	Over-heat protection	Over-heat protection		
	Fan motor	Thermal switch	Thermal switch	Thermal switch	Thermal switch		
	Refrigerant	Type x original charge	R410A x 9.5kg (21lbs)	R410A x 9.5kg (21lbs)	R410A x 11.8kg (27lbs)		
Net weight	kg (lbs)	240(530)	240(530)	240(530)	270(596)		
Heat exchanger	Salt-resistant cross fin & copper tube	Salt-resistant cross fin & copper tube	Salt-resistant cross fin & copper tube	Salt-resistant cross fin & copper tube			
Optional parts	Joint: CMY-Y102SS-G2, CMY-Y102LS-G2, CMY-R160-J1	Joint: CMY-Y102SS-G2, CMY-Y102LS-G2, CMY-R160-J1	Joint: CMY-Y102SS-G2, CMY-Y102LS-G2, CMY-R160-J1	Joint: CMY-Y102SS-G2, CMY-Y102LS-G2, CMY-R160-J1			
	BC controller: CMB-P108, 1010, 1013, 1016V-G1	BC controller: CMB-P108, 1010, 1013, 1016V-G1	BC controller: CMB-P108, 1010, 1013, 1016V-G1	BC controller: CMB-P108, 1010, 1013, 1016V-G1			
	Main BC controller: CMB-P108, 1010, 1013, 1016V-GA1	Main BC controller: CMB-P108, 1010, 1013, 1016V-GA1	Main BC controller: CMB-P108, 1010, 1013, 1016V-GA1	Main BC controller: CMB-P108, 1010, 1013, 1016V-GA1			
	Sub BC controller: CMB-P104, 108V, GB1, CMB-P1016V-HB1	Sub BC controller: CMB-P104, 108V, GB1, CMB-P1016V-HB1	Sub BC controller: CMB-P104, 108V, GB1, CMB-P1016V-HB1	Sub BC controller: CMB-P104, 108V, GB1, CMB-P1016V-HB1			

### Notes:

\*1, \*2 Nominal conditions

	Indoor	Outdoor	Pipe length	Level difference
Cooling	27°C DB/19°C WB (81°F DB/66°F WB)	35°C DB(95°F DB)	7.5m (24-9/16ft.)	0m (0ft.)
Heating	20°C DB(68°F DB)	7°C DB/6°C WB(45°F DB/43°F WB)	7.5m (24-9/16ft.)	0m (0ft.)

\*3 -5°C DB (23°F DB) / -6°C WB (21°F WB) to 21°C DB (70°F DB) / 15.5°C WB (60°F WB) with cooling/heating mixed operation.

\*4 External static pressure option is available (30Pa, 60Pa / 3.1mmH₂O, 6.1mmH₂O).

\*Nominal condition \*1, \*2 are subject to JIS B8615-1.

\*Due to continuing improvement, above specification may be subject to change without notice.

# OUTDOOR UNIT R2 Series - High COP PURY-EP YSJM-A(1)(-BS)

## > Specifications



Model	PURY-EP500YSJM-A(1)(-BS)		PURY-EP550YSJM-A(1)(-BS)		PURY-EP600YSJM-A(1)(-BS)	
Power source	3-phase 4-wire 380-400-415V 50/60Hz					
Cooling capacity (Nominal)	*1 kW	56.0	63.0	69.0		
	*1 BTU/h	191,100	215,000	235,400		
	Power input kW	13.96	15.40	16.87		
	Current input A	23.5-22.3-21.5	25.9-24.6-23.8	28.4-27.0-26.0		
	COP kW/kW	4.01	4.09	4.09		
Temp. range of cooling	*3 Indoor W.B.	15.0~24.0°C(59~75°F)	15.0~24.0°C(59~75°F)	15.0~24.0°C(59~75°F)		
	*3 Outdoor D.B.	-5.0~46.0°C(23~115°F)	-5.0~46.0°C(23~115°F)	-5.0~46.0°C(23~115°F)		
Heating capacity (Nominal)	*2 kW	63.0	69.0	76.5		
	*2 BTU/h	215,000	235,400	261,000		
	Power input kW	14.78	15.93	17.38		
	Current input A	24.9-23.7-22.8	26.8-25.5-24.6	29.3-27.8-26.8		
	COP kW/kW	4.26	4.33	4.40		
Temp. range of heating	*3 Indoor D.B.	15.0~27.0°C(59~81°F)	15.0~27.0°C(59~81°F)	15.0~27.0°C(59~81°F)		
	*3 Outdoor W.B.	-20.0~15.5°C(-4~60°F)	-20.0~15.5°C(-4~60°F)	-20.0~15.5°C(-4~60°F)		
Indoor unit connectable	Total capacity	50~150 % of outdoor unit capacity		50~150 % of outdoor unit capacity		
	Model / Quantity	P15~P250 / 1~50		P15~P250 / 2~50		
Sound pressure level (measured in anechoic room)	dB <A>	63	63	63		
Power pressure level (measured in anechoic room)	dB <A>	83	83	83		
Refrigerant piping diameter	High pressure mm (in.)	22.2(7/8) Braze	28.58(1-1/8) Braze	28.58(1-1/8) Braze		
	Low pressure mm (in.)	28.58(1-1/8) Braze	28.58(1-1/8) Braze	28.58(1-1/8) Braze		
<b>Set Model</b>						
Model	PURY-EP250YJM-A(-BS)	PURY-EP300YJM-A(-BS)	PURY-EP350YJM-A(-BS)	PURY-EP400YJM-A(-BS)	PURY-EP450YJM-A(-BS)	PURY-EP500YJM-A(-BS)
FAN	Type x Quantity	Propeller fan x 1		Propeller fan x 1		Propeller fan x 1
	Air flow rate	m³/min	225	225	225	225
		L/s	3,750	3,750	3,750	3,750
		cfm	7,945	7,945	7,945	7,945
	Driving mechanism	Inverter-control, Direct-driven by motor				
	Motor output kW	0.92 x 1	0.92 x 1	0.92 x 1	0.92 x 1	0.92 x 1
	*4 External static press.	0 Pa (0 mmH₂O)	0 Pa (0 mmH₂O)	0 Pa (0 mmH₂O)	0 Pa (0 mmH₂O)	0 Pa (0 mmH₂O)
Compressor	Type x Quantity	Inverter scroll hermetic compressor		Inverter scroll hermetic compressor		Inverter scroll hermetic compressor
	Starting method	Inverter				
	Motor output kW	6.8	6.8	6.8	7.8	7.8
	Case heater kW	0.045(240 V)	0.045(240 V)	0.045(240 V)	0.045(240 V)	0.045(240 V)
External finish		Pre-coated galvanized steel sheets (+powder coating for -BS type) <MUNSELL 5Y 8/1 or similar>		Pre-coated galvanized steel sheets (+powder coating for -BS type) <MUNSELL 5Y 8/1 or similar>		Pre-coated galvanized steel sheets (+powder coating for -BS type) <MUNSELL 5Y 8/1 or similar>
External dimension HxWxD	mm	1,710(1,650 without legs) x 1,220 x 760	1,710(1,650 without legs) x 1,220 x 760	1,710(1,650 without legs) x 1,220 x 760	1,710(1,650 without legs) x 1,220 x 760	1,710(1,650 without legs) x 1,220 x 760
	in.	67-3/8(65 without legs) x 48-1/16 x 29-15/16	67-3/8(65 without legs) x 48-1/16 x 29-15/16	67-3/8(65 without legs) x 48-1/16 x 29-15/16	67-3/8(65 without legs) x 48-1/16 x 29-15/16	67-3/8(65 without legs) x 48-1/16 x 29-15/16
Protection devices	High pressure protection	High pressure sensor, High pressure switch at 4.15MPa (601 psi)		High pressure sensor, High pressure switch at 4.15MPa (601 psi)		High pressure sensor, High pressure switch at 4.15MPa (601 psi)
	Inverter circuit (COMP./FAN)	Over-heat protection, Over-current protection		Over-heat protection, Over-current protection		Over-heat protection, Over-current protection
	Compressor	Over-heat protection				
	Fan motor	Thermal switch				
Refrigerant	Type x original charge	R410A x 11.8kg (27lbs)	R410A x 11.8kg (27lbs)	R410A x 11.8kg (27lbs)	R410A x 11.8kg (27lbs)	R410A x 11.8kg (27lbs)
Net weight	kg (lbs)	270(596)	270(596)	270(596)	270(596)	270(596)
Heat exchanger		Salt-resistant cross fin & copper tube		Salt-resistant cross fin & copper tube		Salt-resistant cross fin & copper tube
Pipe between unit and distributor	High pressure mm (in.)	19.05(3/4) Braze	19.05(3/4) Braze	19.05(3/4) Braze	19.05(3/4) Braze	19.05(3/4) Braze
	Low pressure mm (in.)	22.2(7/8) Braze	22.2(7/8) Braze	22.2(7/8) Braze	22.2(7/8) Braze	22.2(7/8) Braze
Optional parts		Outdoor Twinning kit: CMY-R100VBK Joint: CMY-Y102SS-G2, CMY-Y102LS-G2, CMY-R160-J1 Main BC controller: CMB-P108, 1010, 1013, 1016V-GA1 Sub BC controller: CMB-P104, 108V-GB1, CMB-P1016V-HB1		Outdoor Twinning kit: CMY-R100VBK Joint: CMY-Y102SS-G2, CMY-Y102LS-G2, CMY-R160-J1 Main BC controller: CMB-P108, 1010, 1013, 1016V-GA1 Sub BC controller: CMB-P104, 108V-GB1, CMB-P1016V-HB1		Outdoor Twinning kit: CMY-R100VBK Joint: CMY-Y102SS-G2, CMY-Y102LS-G2, CMY-R160-J1 Main BC controller: CMB-P108, 1010, 1013, 1016V-GA1 Sub BC controller: CMB-P104, 108V-GB1, CMB-P1016V-HB1

### Notes:

\*1, \*2 Nominal conditions

	Indoor	Outdoor	Pipe length	Level difference
Cooling	27°C DB/19°C WB (81°F DB/66°F WB)	35°C DB(95°F DB)	7.5m (24-9/16ft.)	0m (0ft.)
Heating	20°C DB(68°F DB)	7°C DB/6°C WB(45°F DB/43°F WB)	7.5m (24-9/16ft.)	0m (0ft.)

\*3 -5°C DB (23°F DB) / -6°C WB (21°F WB) to 21°C DB (70°F DB) / 15.5°C WB (60°F WB) with cooling/heating mixed operation.

\*4 External static pressure option is available (30Pa, 60Pa / 3.1mmH<sub>2</sub>O, 6.1mmH<sub>2</sub>O).

\*Nominal condition \*1, \*2 are subject to JIS B8615-1.

\*Due to continuing improvement, above specification may be subject to change without notice.

Outdoor unit

# OUTDOOR UNIT R2 Series - High COP PURY-EP YSJM-A(1)(-BS)

## > Specifications



Model	PURY-EP600YSJM-A(1)(-BS)		PURY-EP650YSJM-A(1)(-BS)		PURY-EP700YSJM-A(1)(-BS)	
Power source	3-phase 4-wire 380-400-415V 50/60Hz					
Cooling capacity (Nominal)	*1 kW	69.0	73.0	80.0		
	*1 BTU/h	235,400	249,100	273,000		
	Power input kW	17.82	19.01	21.22		
	Current input A	30.0-28.5-27.5	32.0-30.4-29.3	35.8-34.0-32.8		
	COP kW/kW	3.87	3.84	3.77		
Temp. range of cooling	*3 Indoor W.B.	15.0~24.0°C(59~75°F)	15.0~24.0°C(59~75°F)	15.0~24.0°C(59~75°F)		
	*3 Outdoor D.B.	-5.0~46.0°C(23~115°F)	-5.0~46.0°C(23~115°F)	-5.0~46.0°C(23~115°F)		
Heating capacity (Nominal)	*2 kW	76.5	81.5	88.0		
	*2 BTU/h	261,000	278,100	300,300		
	Power input kW	18.30	19.73	22.05		
	Current input A	30.8-29.3-28.2	33.3-31.6-30.4	37.2-35.3-34.0		
	COP kW/kW	4.18	4.13	3.99		
Temp. range of heating	*3 Indoor D.B.	15.0~27.0°C(59~81°F)	15.0~27.0°C(59~81°F)	15.0~27.0°C(59~81°F)		
	*3 Outdoor W.B.	-20.0~15.5°C(-4~60°F)	-20.0~15.5°C(-4~60°F)	-20.0~15.5°C(-4~60°F)		
Indoor unit connectable	Total capacity	50~150 % of outdoor unit capacity		50~150 % of outdoor unit capacity		
	Model / Quantity	P15~P250 / 2~50		P15~P250 / 2~50		
Sound pressure level (measured in anechoic room)	dB <A>	63.5	63.5	64		
Power pressure level (measured in anechoic room)	dB <A>	83.5	83.5	84		
Refrigerant piping diameter	High pressure mm (in.)	28.58(1-1/8) Braze	28.58(1-1/8) Braze	28.58(1-1/8) Braze		
	Low pressure mm (in.)	28.58(1-1/8) Braze	28.58(1-1/8) Braze	34.93(1-3/8) Braze		
<b>Set Model</b>						
Model	PURY-EP350YJM-A(-BS)	PURY-EP350YJM-A(-BS)	PURY-EP350YJM-A(-BS)	PURY-EP350YJM-A(-BS)	PURY-EP350YJM-A(-BS)	PURY-EP350YJM-A(-BS)
FAN	Type x Quantity	Propeller fan x 1	Propeller fan x 2	Propeller fan x 1	Propeller fan x 2	Propeller fan x 2
	Air flow rate	m³/min	225	360	225	360
		L/s	3,750	6,000	3,750	6,000
		cfm	7,945	12,712	7,945	12,712
	Driving mechanism	Inverter-control, Direct-driven by motor				
	Motor output kW	0.92 x 1	0.92 x 2	0.92 x 1	0.92 x 2	0.92 x 2
	*4 External static press.	0 Pa (0 mmH₂O)	0 Pa (0 mmH₂O)	0 Pa (0 mmH₂O)	0 Pa (0 mmH₂O)	0 Pa (0 mmH₂O)
Compressor	Type x Quantity	Inverter scroll hermetic compressor		Inverter scroll hermetic compressor		Inverter scroll hermetic compressor
	Starting method	Inverter				
	Motor output kW	6.8	9.9	7.8	9.9	9.9
	Case heater kW	0.045(240 V)	0.045(240 V)	0.045(240 V)	0.045(240 V)	0.045(240 V)
External finish		Pre-coated galvanized steel sheets (+powder coating for -BS type) <MUNSELL 5Y 8/1 or similar>		Pre-coated galvanized steel sheets (+powder coating for -BS type) <MUNSELL 5Y 8/1 or similar>		Pre-coated galvanized steel sheets (+powder coating for -BS type) <MUNSELL 5Y 8/1 or similar>
External dimension HxWxD	mm	1,710(1,650 without legs) x 1,220 x 760	1,710(1,650 without legs) x 1,750 x 760	1,710(1,650 without legs) x 1,220 x 760	1,710(1,650 without legs) x 1,750 x 760	1,710(1,650 without legs) x 1,750 x 760
	in.	67-3/8(65 without legs) x 48-1/16 x 29-15/16	67-3/8(65 without legs) x 68-15/16 x 29-15/16	67-3/8(65 without legs) x 48-1/16 x 29-15/16	67-3/8(65 without legs) x 68-15/16 x 29-15/16	67-3/8(65 without legs) x 68-15/16 x 29-15/16
Protection devices	High pressure protection	High pressure sensor, High pressure switch at 4.15MPa (601 psi)		High pressure sensor, High pressure switch at 4.15MPa (601 psi)		High pressure sensor, High pressure switch at 4.15MPa (601 psi)
	Inverter circuit (COMP./FAN)	Over-heat protection, Over-current protection		Over-heat protection, Over-current protection		Over-heat protection, Over-current protection
	Compressor	Over-heat protection				
	Fan motor	Thermal switch				
Refrigerant	Type x original charge	R410A x 11.8kg (27lbs)	R410A x 11.8kg (27lbs)	R410A x 11.8kg (27lbs)	R410A x 11.8kg (27lbs)	R410A x 11.8kg (27lbs)
Net weight	kg (lbs)	270(596)	320(706)	270(596)	320(706)	320(706)
Heat exchanger		Salt-resistant cross fin & copper tube		Salt-resistant cross fin & copper tube		Salt-resistant cross fin & copper tube
Pipe between unit and distributor	High pressure mm (in.)	19.05(3/4) Braze	19.05(3/4) Braze	19.05(3/4) Braze	19.05(3/4) Braze	19.05(3/4) Braze
	Low pressure mm (in.)	22.2(7/8) Braze	22.2(7/8) Braze	22.2(7/8) Braze	22.2(7/8) Braze	22.2(7/8) Braze
Optional parts		Outdoor Twinning kit: CMY-R100XLVBK Joint: CMY-Y102SS-G2, CMY-Y102LS-G2, CMY-R160-J1 Main BC controller: CMB-P108, 1010, 1013, 1016V-GA1 Sub BC controller: CMB-P104, 108V-GB1, CMB-P1016V-HB1		Outdoor Twinning kit: CMY-R100XLVBK Joint: CMY-Y102SS-G2, CMY-Y102LS-G2, CMY-R160-J1 Main BC controller: CMB-P108, 1010, 1013, 1016V-GA1 Sub BC controller: CMB-P104, 108V-GB1, CMB-P1016V-HB1		Outdoor Twinning kit: CMY-R100XLVBK Joint: CMY-Y102SS-G2, CMY-Y102LS-G2, CMY-R160-J1 Main BC controller: CMB-P108, 1010, 1013, 1016V-GA1 Sub BC controller: CMB-P104, 108V-GB1, CMB-P1016V-HB1

### Notes:

\*1, \*2 Nominal conditions

	Indoor	Outdoor	Pipe length	Level difference
Cooling	27°C DB/19°C WB (81°F DB/66°F WB)	35°C DB(95°F DB)	7.5m (24-9/16ft.)	0m (0ft.)
Heating	20°C DB(68°F DB)	7°C DB/6°C WB(45°F DB/43°F WB)	7.5m (24-9/16ft.)	0m (0ft.)

\*3 -5°C DB (23°F DB) / -6°C WB (21°F WB) to 21°C DB (70°F DB) / 15.5°C WB (60°F WB) with cooling/heating mixed operation.

\*4 External static pressure option is available (30Pa, 60Pa / 3.1mmH<sub>2</sub>O, 6.1mmH<sub>2</sub>O).

\*Nominal condition \*1, \*2 are subject to JIS B8615-1.

\*Due to continuing improvement, above specification may be subject to change without notice.

Outdoor Unit

# HEAT SOURCE UNIT WR2 (Heat Recovery) Series PQRY-P YHM-A



## ► Specifications

Model	PQRY-P200YHM-A		PQRY-P250YHM-A		PQRY-P300YHM-A		
Power source	3-phase 4-wire 380-400-415V 50/60Hz		3-phase 4-wire 380-400-415V 50/60Hz		3-phase 4-wire 380-400-415V 50/60Hz		
Cooling capacity (Nominal)	*1	kW	22.4	28.0	33.5		
	*1	BTU / h	76,400	95,500	114,300		
	Power input	kW	3.96	5.51	7.44		
	Current input	A	6.6-6.3-6.1	9.3-8.8-8.5	12.5-11.9-11.5		
COP		kW / kW	5.65	5.08	4.50		
	Indoor	W.B.	15.0~24.0°C(59~75°F)	15.0~24.0°C(59~75°F)	15.0~24.0°C(59~75°F)		
	Circulating water	°C	10.0~45.0°C(50~113°F)	10.0~45.0°C(50~113°F)	10.0~45.0°C(50~113°F)		
Heating capacity (Nominal)	*2	kW	25.0	31.5	37.5		
	*2	BTU / h	85,300	107,500	128,000		
	Power input	kW	4.12	5.80	8.15		
	Current input	A	6.9-6.6-6.3	9.7-9.3-8.9	13.7-13.0-12.5		
COP		kW / kW	6.06	5.43	4.60		
	Indoor	D.B.	15.0~27.0°C(59~81°F)	15.0~27.0°C(59~81°F)	15.0~27.0°C(59~81°F)		
	Circulating water	°C	10.0~45.0°C(50~113°F)	10.0~45.0°C(50~113°F)	10.0~45.0°C(50~113°F)		
Indoor unit connectable	Model / Quantity	50~150 % of heat source unit capacity P15~P250 / 1~20	50~150 % of heat source unit capacity P15~P250 / 1~25	50~150 % of heat source unit capacity P15~P250 / 1~30			
Sound pressure level (measured in anechoic room)	dB <A>	47	49	50			
Refrigerant piping diameter [O.D.]	High pressure	mm (in.)	15.88(5/8) Braze	19.05(3/4) Braze	19.05(3/4) Braze		
	Low pressure	mm (in.)	19.05(3/4) Braze	22.2(7/8) Braze	22.2(7/8) Braze		
Circulating water	Water flow rate	m <sup>3</sup> / h	5.76	5.76	5.76		
		L/min	96	96	96		
	Pressure drop	cfm	3.4	3.4	3.4		
		kPa	17	17	17		
Operating volume range	m <sup>3</sup> / h	4.5 ~ 7.2	4.5 ~ 7.2	4.5 ~ 7.2			
Compressor	Type x Quantity	Inverter scroll hermetic compressor		Inverter scroll hermetic compressor		Inverter scroll hermetic compressor	
	Starting method	Inverter		Inverter		Inverter	
	Motor output	kW	4.6	6.3	7.4		
	Case heater	kW	0.035(240 V)	0.035(240 V)	0.035(240 V)		
External finish		Acrylic painted steel plate		Acrylic painted steel plate		Acrylic painted steel plate	
External dimension HxWxD	mm	1,160(1,100 without legs) x 880 x 550		1,160(1,100 without legs) x 880 x 550		1,160(1,100 without legs) x 880 x 550	
	in.	45-11/16(43-5/16 without legs) x 34-11/16 x 21-11/16		45-11/16(43-5/16 without legs) x 34-11/16 x 21-11/16		45-11/16(43-5/16 without legs) x 34-11/16 x 21-11/16	
Protection devices	High pressure protection	High pressure sensor, High pressure switch at 4.15MPa (601 psi)		High pressure sensor, High pressure switch at 4.15MPa (601 psi)		High pressure sensor, High pressure switch at 4.15MPa (601 psi)	
	Inverter circuit (COMP.)	Over-heat protection, Over-current protection		Over-heat protection, Over-current protection		Over-heat protection, Over-current protection	
	Compressor	Over-heat protection		Over-heat protection		Over-heat protection	
Refrigerant	Type x original charge	R410A x 5.0kg (12lbs)		R410A x 5.0kg (12lbs)		R410A x 5.0kg (12lbs)	
Net weight	kg (lbs)	181(400)		181(400)		181(400)	
Heat exchanger	plate type		plate type		plate type		
	Water volume in plate	L	5.0		5.0		
	Water pressure Max.	MPa	2.0		2.0		
Optional parts		Joint: CMY-Y102SS-G2, CMY-Y102LS-G2, CMY-Y202S-G2, CMY-R160-J1		Joint: CMY-Y102SS-G2, CMY-Y102LS-G2, CMY-Y202S-G2, CMY-R160-J1		Joint: CMY-Y102SS-G2, CMY-Y102LS-G2, CMY-Y202S-G2, CMY-R160-J1	

### Notes:

\*1, \*2 Nominal conditions

	Indoor	Water temperature	Pipe length	Level difference
Cooling	27°C D.B./19°C W.B. (81°F D.B./66°F W.B.)	30°C (86°F)	7.5m (24-9/16ft.)	0m (0ft.)
Heating	20°C D.B. (68°F D.B.)	20°C (68°F)		

- \*3 The ambient temperature of the heat source unit needs to be kept below 40°C D.B.
- \*4 The ambient relative humidity of the heat source unit needs to be kept below 80%.
- \*5 The heat source Unit should not be installed at outdoor.
- \*6 Be sure to mount a strainer (more than 50 meshes) at the water inlet piping of the unit.
- \*7 Be sure to provide interlocking for the unit operation and water circuit.
- \*Nominal condition \*1, \*2 are subject to JIS B8615-1.
- \*Due to continuing improvement, above specification may be subject to change without notice.

Outdoor unit

# HEAT SOURCE UNIT WR2 (Heat Recovery) Series PQRY-P YSHM-A



## ► Specifications

Model	PQRY-P400YSHM-A		PQRY-P450YSHM-A		PQRY-P500YSHM-A		
Power source	3-phase 4-wire 380-400-415V 50/60Hz		3-phase 4-wire 380-400-415V 50/60Hz		3-phase 4-wire 380-400-415V 50/60Hz		
Cooling capacity (Nominal)	*1	kW	45.0	50.0	56.0		
	*1	BTU / h	153,500	170,600	191,100		
	Power input	kW	8.32	9.94	11.57		
	Current input	A	14.0-13.3-12.8	16.7-15.9-15.3	19.5-18.5-17.8		
COP		kW / kW	5.40	5.03	4.84		
	Indoor	W.B.	15.0~24.0°C(59~75°F)	15.0~24.0°C(59~75°F)	15.0~24.0°C(59~75°F)		
	Circulating water	°C	10.0~45.0°C(50~113°F)	10.0~45.0°C(50~113°F)	10.0~45.0°C(50~113°F)		
Heating capacity (Nominal)	*2	kW	50.0	56.0	63.0		
	*2	BTU / h	170,600	191,100	215,000		
	Power input	kW	8.65	10.42	12.06		
	Current input	A	14.6-13.8-13.3	17.5-16.7-16.1	20.3-19.3-18.6		
COP		kW / kW	5.78	5.37	5.22		
	Indoor	D.B.	15.0~27.0°C(59~81°F)	15.0~27.0°C(59~81°F)	15.0~27.0°C(59~81°F)		
	Circulating water	°C	10.0~45.0°C(50~113°F)	10.0~45.0°C(50~113°F)	10.0~45.0°C(50~113°F)		
Indoor unit connectable	Model / Quantity	50~150 % of heat source unit capacity P15~P250 / 1~40	50~150 % of heat source unit capacity P15~P250 / 1~45	50~150 % of heat source unit capacity P15~P250 / 1~50 (Connectable branch pipe number is max. 48.)			
Sound pressure level (measured in anechoic room)	dB <A>	50	51	52			
Refrigerant piping diameter [O.D.]	High pressure	mm (in.)	22.2(7/8) Braze	22.2(7/8) Braze	22.2(7/8) Braze		
	Low pressure	mm (in.)	28.58(1-1/8) Braze	28.58(1-1/8) Braze	28.58(1-1/8) Braze		
Set Model							
Circulating water	Water flow rate	m <sup>3</sup> / h	5.76 + 5.76	5.76 + 5.76	5.76 + 5.76		
		L/min	96 + 96	96 + 96	96 + 96		
	Pressure drop	cfm	3.4 + 3.4	3.4 + 3.4	3.4 + 3.4		
		kPa	17	17	17		
Operating volume range	m <sup>3</sup> / h	4.5 + 4.5 ~ 7.2 + 7.2	4.5 + 4.5 ~ 7.2 + 7.2	4.5 + 4.5 ~ 7.2 + 7.2			
Compressor	Type x Quantity	Inverter scroll hermetic compressor		Inverter scroll hermetic compressor		Inverter scroll hermetic compressor	
	Starting method	Inverter		Inverter		Inverter	
	Motor output	kW	4.6	6.3	4.6	6.3	6.3
	Case heater	kW	0.035(240 V)	0.035(240 V)	0.035(240 V)	0.035(240 V)	0.035(240 V)
External finish		Acrylic painted steel plate		Acrylic painted steel plate		Acrylic painted steel plate	
External dimension HxWxD	mm	1,160(1,100 without legs) x 880 x 550		1,160(1,100 without legs) x 880 x 550		1,160(1,100 without legs) x 880 x 550	
	in.	45-11/16(43-5/16 without legs) x 34-11/16 x 21-11/16		45-11/16(43-5/16 without legs) x 34-11/16 x 21-11/16		45-11/16(43-5/16 without legs) x 34-11/16 x 21-11/16	
Protection devices	High pressure protection	High pressure sensor, High pressure switch at 4.15MPa (601 psi)		High pressure sensor, High pressure switch at 4.15MPa (601 psi)		High pressure sensor, High pressure switch at 4.15MPa (601 psi)	
	Inverter circuit (COMP.)	Over-heat protection, Over-current protection		Over-heat protection, Over-current protection		Over-heat protection, Over-current protection	
	Compressor	Over-heat protection		Over-heat protection		Over-heat protection	
Refrigerant	Type x original charge	R410A x 5.0kg (12lbs)		R410A x 5.0kg (12lbs)		R410A x 5.0kg (12lbs)	
Net weight	kg (lbs)	181(400)		181(400)		181(400)	
Heat exchanger	plate type		plate type		plate type		
	Water volume in plate	L	5.0		5.0		
	Water pressure Max.	MPa	2.0		2.0		
Optional parts		Heat Source Twinning kit: CMY-Q100VBK Joint: CMY-Y102SS-G2, CMY-Y102LS-G2, CMY-Y202S-G2, CMY-R160-J1		Heat Source Twinning kit: CMY-Q100VBK Joint: CMY-Y102SS-G2, CMY-Y102LS-G2, CMY-Y202S-G2, CMY-R160-J1		Heat Source Twinning kit: CMY-Q100VBK Joint: CMY-Y102SS-G2, CMY-Y102LS-G2, CMY-Y202S-G2, CMY-R160-J1	

### Notes:

\*1, \*2 Nominal conditions

	Indoor	Water temperature	Pipe length	Level difference
Cooling	27°C D.B./19°C W.B. (81°F D.B./66°F W.B.)	30°C (86°F)	7.5m (24-9/16ft.)	0m (0ft.)
Heating	20°C D.B. (68°F D.B.)	20°C (68°F)		

- \*3 The ambient temperature of the heat source unit needs to be kept below 40°C D.B.
- \*4 The ambient relative humidity of the heat source unit needs to be kept below 80%.
- \*5 The heat source Unit should not be installed at outdoor.
- \*6 Be sure to mount a strainer (more than 50 meshes) at the water inlet piping of the unit.
- \*7 Be sure to provide interlocking for the unit operation and water circuit.
- \*Nominal condition \*1, \*2 are subject to JIS B8615-1.
- \*Due to continuing improvement, above specification may be subject to change without notice.

Outdoor Unit

# HEAT SOURCE UNIT WR2 (Heat Recovery) Series PQRY-P YSHM-A



## ► Specifications

Model		PQRY-P550YSHM-A		PQRY-P600YSHM-A		
Power source		3-phase 4-wire 380-400-415V 50/60Hz		3-phase 4-wire 380-400-415V 50/60Hz		
Cooling capacity (Nominal)	*1 kW	63.0		69.0		
	*1 BTU / h	215,000		235,400		
	Power input kW	13.60		15.62		
	Current input A	22.9-21.8-21.0		26.3-25.0-24.1		
COP		4.63		4.41		
Temp. range of cooling	Indoor W.B.	15.0~24.0°C(59~75°F)		15.0~24.0°C(59~75°F)		
	Circulating water °C	10.0~45.0°C(50~113°F)		10.0~45.0°C(50~113°F)		
Heating capacity (Nominal)	*2 kW	69.0		76.5		
	*2 BTU / h	235,400		261,000		
	Power input kW	14.65		17.12		
	Current input A	24.7-23.4-22.6		28.9-27.4-26.4		
COP		4.70		4.46		
Temp. range of heating	Indoor D.B.	15.0~27.0°C(59~81°F)		15.0~27.0°C(59~81°F)		
	Circulating water °C	10.0~45.0°C(50~113°F)		10.0~45.0°C(50~113°F)		
Indoor unit connectable	Total capacity	50~150 % of heat source unit capacity		50~150 % of heat source unit capacity		
	Model / Quantity	P15~P250 / 2~50 (Connectable branch pipe number is max. 48.)		P15~P250 / 2~50 (Connectable branch pipe number is max. 48.)		
Sound pressure level (measured in anechoic room)	dB <A>	52.5		53		
Refrigerant piping diameter [O.D.]	High pressure	28.58(1-1/8) Brazed		28.58(1-1/8) Brazed		
	Low pressure	28.58(1-1/8) Brazed		28.58(1-1/8) Brazed		
Set Model						
Model		PQRY-P300YHM-A		PQRY-P250YHM-A		
Circulating water	Water flow rate	m <sup>3</sup> / h	5.76 + 5.76		5.76 + 5.76	
		L/min	96 + 96		96 + 96	
	cfm	3.4 + 3.4		3.4 + 3.4		
	Pressure drop	kPa	17		17	
Operating volume range	m <sup>3</sup> / h	4.5 + 4.5 ~ 7.2 + 7.2		4.5 + 4.5 ~ 7.2 + 7.2		
Compressor	Type x Quantity	Inverter scroll hermetic compressor		Inverter scroll hermetic compressor		
	Starting method	Inverter		Inverter		
	Motor output kW	7.4		6.3		
	Case heater	0.035(240 V)		0.035(240 V)		
External finish		Acrylic painted steel plate				
External dimension HxWxD	mm	1,160(1,100 without legs) x 880 x 550		1,160(1,100 without legs) x 880 x 550		
	in.	45-11/16(43-5/16 without legs) x 34-11/16 x 21-11/16		45-11/16(43-5/16 without legs) x 34-11/16 x 21-11/16		
Protection devices	High pressure protection	High pressure sensor, High pressure switch at 4.15MPa (601 psi)		High pressure sensor, High pressure switch at 4.15MPa (601 psi)		
	Inverter circuit (COMP.)	Over-heat protection, Over-current protection		Over-heat protection, Over-current protection		
	Compressor	Over-heat protection		Over-heat protection		
Refrigerant	Type x original charge	R410A x 5.0kg (12lbs)		R410A x 5.0kg (12lbs)		
Net weight	kg (lbs)	181(400)		181(400)		
Heat exchanger			plate type		plate type	
	Water volume in plate	L	5.0		5.0	
	Water pressure Max.	MPa	2.0		2.0	
Optional parts		Heat Source Twinning kit: CMY-Q100VBK Joint: CMY-Y102SS-G2,CMY-Y102LS-G2,CMY-Y202SS-G2,CMY-R160-J1		Heat Source Twinning kit: CMY-Q100VBK Joint: CMY-Y102SS-G2,CMY-Y102LS-G2,CMY-Y202SS-G2,CMY-R160-J1		

### Notes:

\*1,\*2 Nominal conditions

	Indoor	Water temperature	Pipe length	Level difference
Cooling	27°C D.B./19°C W.B. (81°F D.B./66°F W.B.)	30°C (86°F)	7.5m (24-9/16ft.)	0m (0ft.)
Heating	20°C D.B. (68°F D.B.)	20°C (68°F)		

- \*3 The ambient temperature of the heat source unit needs to be kept below 40°C D.B.
- \*4 The ambient relative humidity of the heat source unit needs to be kept below 80%.
- \*5 The heat source Unit should not be installed at outdoor.
- \*6 Be sure to mount a strainer (more than 50 meshes) at the water inlet piping of the unit.
- \*7 Be sure to provide interlocking for the unit operation and water circuit.
- \*Nominal condition \*1,\*2 are subject to JIS B8615-1.
- \*Due to continuing improvement, above specification may be subject to change without notice.

Outdoor unit

## OPTIONAL PARTS FOR OUTDOOR UNITS

### >>For PUMY series

Description	Model
Branch Pipe (2 Branch)	CMY-Y62-G-E
Header	CMY-Y64-G-E
Header	CMY-Y68-G-E
Drain Socket	PAC-SG61DS-E
Centralized Drain Pan	PAC-SG64DP-E
Port Connector (ø9.52 → ø12.7)	PAC-SG73RJ-E
Port Connector (ø15.88 → ø19.05)	PAC-SG75RJ-E
Air Protect Guide (2 pcs required)	PAC-SH63AG-E

### >>For PUHY series

Description	Model	Remarks
Twinning kit	CMY-Y100VBK2	For PUHY-P500~P650 / EP400~EP600YSJM
	CMY-Y200VBK2	For PUHY-P700~P900YSHM
	CMY-Y300VBK2	For PUHY-P950~P1250 / EP650~EP900YSJM
Branch pipe (Joint)	CMY-Y102SS-G2	200 or below (Total capacity of indoor unit)
	CMY-Y102LS-G2	201-400 (Total capacity of indoor unit)
	CMY-Y202S-G2	401-650 (Total capacity of indoor unit) The 1st branch of P450~P650
	CMY-Y302S-G2	651 or above (Total capacity of indoor unit) The 1st branch of P700~P1250
Branch pipe (Header)	CMY-Y104-G	For 4 branches
	CMY-Y108-G	For 8 branches
	CMY-Y1010-G	For 10 branches

Note : Indoor unit capacities: the capacity of an indoor unit is the same as the number used for its type identification.

### >>For PUHY-HP series

Description	Model	Remarks
Branch pipe (Joint)	CMY-Y102SS-G2	200 or below (Total capacity of indoor unit)
	CMY-Y102LS-G2	201-400 (Total capacity of indoor unit)
	CMY-Y202S-G2	401-650 (Total capacity of indoor unit) The 1st branch of P400,P500
Branch pipe (Header)	CMY-Y104-G	For 4 branches
	CMY-Y108-G	For 8 branches
	CMY-Y1010-G	For 10 branches
Twinning kit	CMY-Y100VBK2	For PUHY-HP400,HP500YSHM-A(BS)

Note : Indoor unit capacities: the capacity of an indoor unit is the same as the number used for its type identification.

### >>For PURY series

Description	Model	Remarks
Twinning kit	CMY-R100VBK	For PURY-P400~P650 / EP400~EP600YSHM
	CMY-R200VBK	For PURY-P700~P800YSHM
	CMY-R100XLVBK	For PURY-P800 / EP600~650YSJM
	CMY-R200XLVBK	For PURY-P850~900 / EP700YSJM
Branch pipe (Joint)	CMY-Y102SS-G2	200 or below (Total capacity of indoor unit)
	CMY-Y102LS-G2	201-400 (Total capacity of indoor unit)
	CMY-Y202S-G2	401-650 (Total capacity of indoor unit) The 1st branch of P450~P650

Note : Indoor unit capacities: the capacity of an indoor unit is the same as the number used for its type identification.

### >>For PQHY series

Description	Model	Remarks
Branch pipe (Joint)	CMY-Y102SS-G2	200 or below (Total capacity of indoor unit)
	CMY-Y102LS-G2	201-400 (Total capacity of indoor unit)
	CMY-Y202S-G2	401-650 (Total capacity of indoor unit) The first branch of P400-P600
	CMY-Y302S-G2	651 or above (Total capacity of indoor unit)
Branch pipe (Header)	CMY-Y104-G	For 4 branches
	CMY-Y108-G	For 8 branches
	CMY-Y1010-G	For 10 branches
Twinning kit	CMY-Y100VBK2	For PQHY-P400-P900YSHM-A

### >>For PQR series

Description	Model	Remarks
Branch pipe (Joint)	CMY-Y102SS-G2	200 or below (Total capacity of indoor unit)
	CMY-Y102LS-G2	201-400 (Total capacity of indoor unit)
	CMY-Y202S-G2	401-650 (Total capacity of indoor unit) The first branch of P400-P600
Twinning kit	CMY-Q100VBK	For PQR-P400-P600YSHM-A

## OPTIONAL PARTS FOR CONTROL

Model	Description	Model	Description
PAC-SE41TS-E	Remote Sensor for A/J/K/M-Net Control	PAC-YT41HAA	External input/output adapter for AT-50A
PAC-SE55RA-E	Remote ON/OFF adaptor for Indoor Unit	PAC-YG10HA	External input/output adapter for AG-150A
PAC-SA88HA-EP	Remote Display Adaptor for Indoor Unit	PAC-YG50ECA	Expansion controller for AG-150A
PAC-SA89TA-EP	Timer Adaptor for remote controller	PAC-SC51KUA	Power supply unit for AG-150A / GB-50ADA-J
PAC-SC37SA-E	Output signal connector	PAC-YG81TB	Mounting attachment B type for AG-150A wall-mount installations
PAC-SC36NA-E	Input signal connector	PAC-YG83UTB	Electric box for AG-150A wall-embed installations
PAC-SF46EPA	Transmission booster	PAC-YG85KTB	Mounting attachment A type for AG-150A/PAC-SC51KUA wall-mount installations
LMAF02	Air conditioner interface	PAC-YG71CBL	Black surface cover for AG-150A
PAC-YG11CDA	Electric amount count software		
PAC-YG31CDA	BAC net® interface		
BAC-HD150	BAC net® and M-NET adapter		

## OPTIONAL EQUIPMENT FOR BC CONTROLLER

BC Controller Model	Junction pipe kit	Branch pipe
CMB-P104V-G1, GB1	CMY-R160-J1	CMY-Y102SS-G2
CMB-P105V-G1		
CMB-P106V-G1		
CMB-P108V-G1, GA1, GB1		
CMB-P1010V-G1, GA1		
CMB-P1013V-G1, GA1		
CMB-P1016V-G1, GA1, HA1, HB1		

## Maintenance equipment

### Maintenance cycle [Note that maintenance cycle does not mean guarantee period.]

The following tables are applicable when using equipment under the conditions below.

- Normal use without frequent START/STOPS (The number of START/STOPS is assumed to be less than 6 times per hour in normal use.)
- Operating hours are assumed to be 10 hours per day/2500 hours per year.

Under the following conditions, equipment may not be able to be used at all, or the maintenance cycle and replacement cycle of equipment may need to be shortened.

- When using equipment in high temperature and humidity or in rapid changes in temperature and humidity
- When using equipment in a big electric change of power voltage, frequency, and waveform distortion (They cannot be used outside of acceptable range.)
- When using equipment installed in a place where there is a lot of vibration
- When using equipment in the air with hazardous gas or oil mist as well as dust, salinity, and sulfur dioxide/hydrogen sulfide
- When using equipment with frequent START/STOP or long operating hours

Table 1. Maintenance cycle

Major components	Checking cycle	Maintenance cycle	Major components	Checking cycle	Maintenance cycle
Compressor	1 year	20,000 hours	Expansion valve	1 year	20,000 hours
Motor (Fan, Louver, drain pump)		20,000 hours	Valve (solenoid valve, four-way valve)		20,000 hours
Bearing		15,000 hours	Sensor (thermistor, presser sensor)		5 years
Electric board		25,000 hours	Drain pan		8 years
Heat exchanger		5 years			

Note1 This table shows major components. Refer to the maintenance contract for details.

Note2 This maintenance cycle shows a period in which products are expected to require no maintenance. Use this cycle for planning maintenance (budgeting the maintenance expense etc.) Checking/ Maintenance cycle may be shorter than the one on this table depending on the contents of maintenance check contract.

- Sudden unpredictable accident may occur even if check-up is performed.

### Replacement cycle of consumable components

[Note that replacement cycle does not mean guarantee period.]

Table 2. Replacement cycle

Major components	Checking cycle	Replacement cycle
Long-life filter	1 year	5 years
High-performance filter		1 year
Fan belt		5,000 hours
Smoothing capacitor		10 years
Fuse		10 years
Crank case heater		8 years

Note1 This table shows major components. Refer to the maintenance contract for details.

Note2 This replacement cycle shows a period in which products are expected to require no replacements. Use this cycle for planning maintenance (budgeting expenses for replacing equipments etc.)

## OPTIONAL PARTS FOR OUTDOOR UNITS

### >>For PUMY series

Description	Model
Branch Pipe (2 Branch)	CMY-Y62-G-E
Header	CMY-Y64-G-E
Header	CMY-Y68-G-E
Drain Socket	PAC-SG61DS-E
Centralized Drain Pan	PAC-SG64DP-E
Port Connector (ø9.52 → ø12.7)	PAC-SG73RJ-E
Port Connector (ø15.88 → ø19.05)	PAC-SG75RJ-E
Air Protect Guide (2 pcs required)	PAC-SH63AG-E

### >>For PUHY series

Description	Model	Remarks
Twinning kit	CMY-Y100VBK2	For PUHY-P500~P650 / EP400~EP600YSJM
	CMY-Y200VBK2	For PUHY-P700~P900YSHM
	CMY-Y300VBK2	For PUHY-P950~P1250 / EP650~EP900YSJM
Branch pipe (Joint)	CMY-Y102SS-G2	200 or below (Total capacity of indoor unit)
	CMY-Y102LS-G2	201-400 (Total capacity of indoor unit)
	CMY-Y202S-G2	401-650 (Total capacity of indoor unit) The 1st branch of P450~P650
	CMY-Y302S-G2	651 or above (Total capacity of indoor unit) The 1st branch of P700~P1250
Branch pipe (Header)	CMY-Y104-G	For 4 branches
	CMY-Y108-G	For 8 branches
	CMY-Y1010-G	For 10 branches

Note : Indoor unit capacities: the capacity of an indoor unit is the same as the number used for its type identification.

### >>For PUHY-HP series

Description	Model	Remarks
Branch pipe (Joint)	CMY-Y102SS-G2	200 or below (Total capacity of indoor unit)
	CMY-Y102LS-G2	201-400 (Total capacity of indoor unit)
	CMY-Y202S-G2	401-650 (Total capacity of indoor unit) The 1st branch of P400,P500
Branch pipe (Header)	CMY-Y104-G	For 4 branches
	CMY-Y108-G	For 8 branches
	CMY-Y1010-G	For 10 branches
Twinning kit	CMY-Y100VBK2	For PUHY-HP400,HP500YSHM-A(BS)

Note : Indoor unit capacities: the capacity of an indoor unit is the same as the number used for its type identification.

### >>For PURY series

Description	Model	Remarks
Twinning kit	CMY-R100VBK	For PURY-P400~P650 / EP400~EP600YSHM
	CMY-R200VBK	For PURY-P700~P800YSHM
	CMY-R100XLVBK	For PURY-P800 / EP600~650YSJM
	CMY-R200XLVBK	For PURY-P850~900 / EP700YSJM
Branch pipe (Joint)	CMY-Y102SS-G2	200 or below (Total capacity of indoor unit)
	CMY-Y102LS-G2	201-400 (Total capacity of indoor unit)
	CMY-Y202S-G2	401-650 (Total capacity of indoor unit) The 1st branch of P450~P650

Note : Indoor unit capacities: the capacity of an indoor unit is the same as the number used for its type identification.

### >>For PQHY series

Description	Model	Remarks
Branch pipe (Joint)	CMY-Y102SS-G2	200 or below (Total capacity of indoor unit)
	CMY-Y102LS-G2	201-400 (Total capacity of indoor unit)
	CMY-Y202S-G2	401-650 (Total capacity of indoor unit) The first branch of P400-P600
	CMY-Y302S-G2	651 or above (Total capacity of indoor unit)
Branch pipe (Header)	CMY-Y104-G	For 4 branches
	CMY-Y108-G	For 8 branches
	CMY-Y1010-G	For 10 branches
Twinning kit	CMY-Y100VBK2	For PQHY-P400-P900YSHM-A

### >>For PQR series

Description	Model	Remarks
Branch pipe (Joint)	CMY-Y102SS-G2	200 or below (Total capacity of indoor unit)
	CMY-Y102LS-G2	201-400 (Total capacity of indoor unit)
	CMY-Y202S-G2	401-650 (Total capacity of indoor unit) The first branch of P400-P600
Twinning kit	CMY-Q100VBK	For PQR-P400-P600YSHM-A

## OPTIONAL PARTS FOR CONTROL

Model	Description	Model	Description
PAC-SE41TS-E	Remote Sensor for A/J/K/M-Net Control	PAC-YT41HAA	External input/output adapter for AT-50A
PAC-SE55RA-E	Remote ON/OFF adaptor for Indoor Unit	PAC-YG10HA	External input/output adapter for AG-150A
PAC-SA88HA-EP	Remote Display Adaptor for Indoor Unit	PAC-YG50ECA	Expansion controller for AG-150A
PAC-SA89TA-EP	Timer Adaptor for remote controller	PAC-SC51KUA	Power supply unit for AG-150A / GB-50ADA-J
PAC-SC37SA-E	Output signal connector	PAC-YG81TB	Mounting attachment B type for AG-150A wall-mount installations
PAC-SC36NA-E	Input signal connector	PAC-YG83UTB	Electric box for AG-150A wall-embed installations
PAC-SF46EPA	Transmission booster	PAC-YG85KTB	Mounting attachment A type for AG-150A/PAC-SC51KUA wall-mount installations
LMAF02	Air conditioner interface	PAC-YG71CBL	Black surface cover for AG-150A
PAC-YG11CDA	Electric amount count software		
PAC-YG31CDA	BAC net® interface		
BAC-HD150	BAC net® and M-NET adapter		

## OPTIONAL EQUIPMENT FOR BC CONTROLLER

BC Controller Model	Junction pipe kit	Branch pipe
CMB-P104V-G1, GB1	CMY-R160-J1	CMY-Y102SS-G2
CMB-P105V-G1		
CMB-P106V-G1		
CMB-P108V-G1, GA1, GB1		
CMB-P1010V-G1, GA1		
CMB-P1013V-G1, GA1		
CMB-P1016V-G1, GA1, HA1, HB1		

## Maintenance equipment

### Maintenance cycle [Note that maintenance cycle does not mean guarantee period.]

The following tables are applicable when using equipment under the conditions below.

- Normal use without frequent START/STOPS (The number of START/STOPS is assumed to be less than 6 times per hour in normal use.)
- Operating hours are assumed to be 10 hours per day/2500 hours per year.

Under the following conditions, equipment may not be able to be used at all, or the maintenance cycle and replacement cycle of equipment may need to be shortened.

- When using equipment in high temperature and humidity or in rapid changes in temperature and humidity
- When using equipment in a big electric change of power voltage, frequency, and waveform distortion (They cannot be used outside of acceptable range.)
- When using equipment installed in a place where there is a lot of vibration
- When using equipment in the air with hazardous gas or oil mist as well as dust, salinity, and sulfur dioxide/hydrogen sulfide
- When using equipment with frequent START/STOP or long operating hours

Table 1. Maintenance cycle

Major components	Checking cycle	Maintenance cycle	Major components	Checking cycle	Maintenance cycle
Compressor	1 year	20,000 hours	Expansion valve	1 year	20,000 hours
Motor (Fan, Louver, drain pump)		20,000 hours	Valve (solenoid valve, four-way valve)		20,000 hours
Bearing		15,000 hours	Sensor (thermistor, presser sensor)		5 years
Electric board Heat exchanger		25,000 hours 5 years	Drain pan		8 years

Note1 This table shows major components. Refer to the maintenance contract for details.

Note2 This maintenance cycle shows a period in which products are expected to require no maintenance. Use this cycle for planning maintenance (budgeting the maintenance expense etc.) Checking/ Maintenance cycle may be shorter than the one on this table depending on the contents of maintenance check contract.

- Sudden unpredictable accident may occur even if check-up is performed.

### Replacement cycle of consumable components

[Note that replacement cycle does not mean guarantee period.]

Table 2. Replacement cycle

Major components	Checking cycle	Replacement cycle
Long-life filter	1 year	5 years
High-performance filter		1 year
Fan belt		5,000 hours
Smoothing capacitor		10 years
Fuse		10 years
Crank case heater		8 years

Note1 This table shows major components. Refer to the maintenance contract for details.

Note2 This replacement cycle shows a period in which products are expected to require no replacements. Use this cycle for planning maintenance (budgeting expenses for replacing equipments etc.)



**for a greener tomorrow**

Eco Changes is the Mitsubishi Electric Group's environmental statement, and expresses the Group's stance on environmental management. Through a wide range of businesses, we are helping contribute to the realization of a sustainable society.



FM33568 / ISO 9001;2008

The Air Conditioning & Refrigeration Systems Works acquired ISO 9001 certification under Series 9000 of the International Standard Organization (ISO) based on a review of Quality management for the production of refrigeration and air conditioning equipment.

**ISO Authorization System**

The ISO 9000 series is a plant authorization system relating to quality management as stipulated by the ISO. ISO 9001 certifies quality management based on the "design, development, production, installation and auxiliary services" for products built at an authorized plant.



The Air Conditioning & Refrigeration Systems Works acquired environmental management system standard ISO 14001 certification.

The ISO 14000 series is a set of standards applying to environmental protection set by the International Standard Organization (ISO). Registered on March 10, 1998.

**△ NOTICE**

- When installing or relocating the air conditioners, use only the specified refrigerant (R410A) to charge the refrigerant lines. Do not mix any other refrigerant and do not allow air to remain the lines. If air is mixed with refrigerant, then it can be the cause of abnormal high pressure in the refrigerant lines, and may result in an explosion and other hazards. The use of any refrigerant other than that specified for the system will cause mechanical failure or system malfunction or unit breakdown. In the worse case, this could lead to a serious impediment to securing product safety. MITSUBISHI ELECTRIC CORPORATION cannot be held responsible for malfunctions or accidents resulting from the use of the wrong type of refrigerant.

**MITSUBISHI ELECTRIC CORPORATION**

<http://Global.MitsubishiElectric.com>