

Trittico M 18

combi machine for gelato & ice cream
hot process production
water cooled

Model:
Quantity:
Project:
Company:
Contact:
Dealer ID:

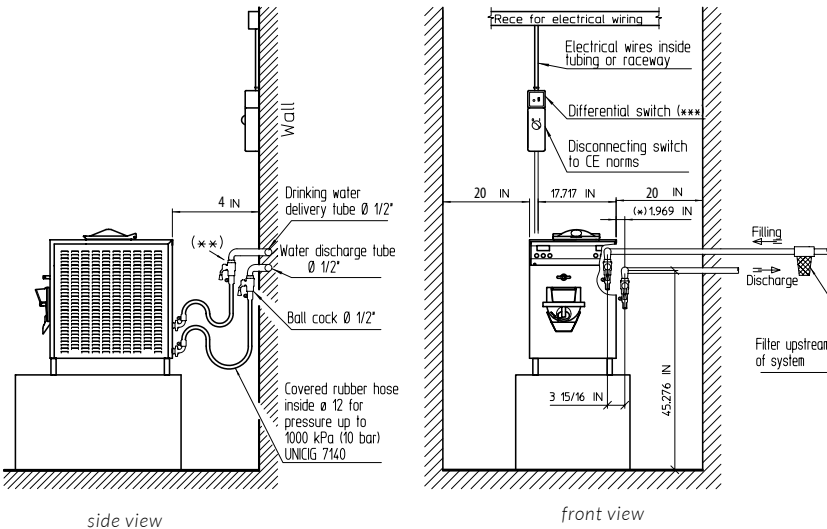
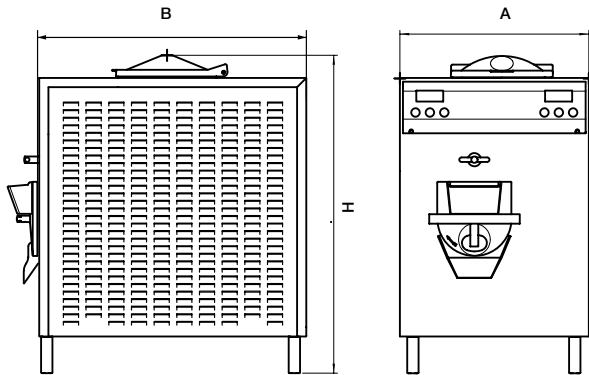

(*) Even if the machine models vary, the water and electricity connection positions are always the same, i.e. on the LEFT side of the machine.
(**) Cocks are in vertical only for illustration purposes.
(***) 30 mA (ABB serie C).

| | | | | |
|-------------------------------|-----------------------|------------|--------|----------------|
| Width (A) | cm | 50 | inches | 19,7 |
| Depth (B) | cm | 81 | inches | 32 |
| Height (H) | cm | 84 | inches | 33,1 |
| Weight | kg | 117 | lbs | 258 |
| Frame type | countertop | | | |
| Outer panels | stainless steel | | | |
| Capacity per cycle | Liters | 3 | Gal | 0,79 |
| Max hourly production | Liters | 18 | Gal | 4,8 |
| Min. mix per cycle | Kg | 1,5 | lbs | 3,3 |
| Max. mix per cycle | Kg | 2,5 | lbs | 5,5 |
| Volume cylinder with mixer | Liters | 5,7 | Quarts | 6 |
| Volume cylinder without mixer | Liters | 6,1 | Quarts | 6,5 |
| Min. mixer speed | RPM 122 | | | |
| Max. mixer speed | RPM 250 | | | |
| Max power | kw | 5,2 | Hp | 7 |
| Voltage | 230 Volt/60Hz/3 phase | | | |
| Running Amps | Amp 17,7 | | | |
| Breaker size | Amp 30 | | | |
| Stirrer motor | kw | 0,22 | Hp | 0,3 |
| Drive motor | kw | 1,1 | Hp | 1,5 |
| Compressor power | kw | 1,2 | Hp | 1,6 |
| Compressor power | BTU/h 3200 | | | |
| Freon R404A | Gr | 1080 | Oz | 38,1 |
| Refrigeration condensation | Water | | | |
| Water connection Npt | cm | 1,27 | inches | 1/2 |
| Min. water pressure | bar | 1,5 | Psi | 20 |
| Max. water pressure | bar | 3 | Psi | 40 |
| Crate dimensions | cm | 100X63X105 | inches | 39,4x24,2x41,3 |
| Crate weight | kg | 159 | lbs | 350 |



Warranty: valid for the North American Continent (Canada, USA)
Extension: 12 months parts (with check list and warranty signed and mailed)
5 years compressor with registration on warranty.bravonorthamerica.com



Bravo North America Inc. Office & Showroom, 810 Tyvola Road, Suite 130, Charlotte, NC 28217
tel. +1 980 237 2474 bravonorthamerica.com info@bravonorthamerica.com

Trittico M 18

combi machine for gelato & ice cream
hot process production
air cooled

Model:
Quantity:
Project:
Company:
Contact:
Dealer ID:

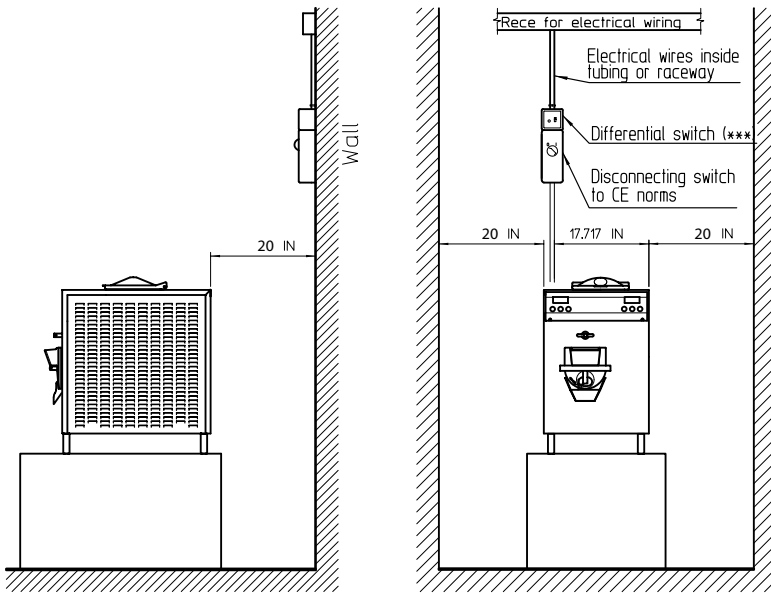
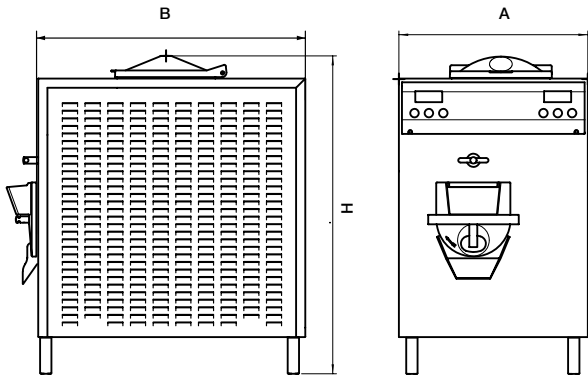

side view

front view

(***) 30 mA (ABB serie C).

| | | | | |
|-------------------------------|-----------------------|------------|--------|----------------|
| Width (A) | cm | 50 | inches | 19,7 |
| Depth (B) | cm | 81 | inches | 32 |
| Height (H) | cm | 84 | inches | 33,1 |
| Weight | kg | 117 | lbs | 258 |
| Frame type | countertop | | | |
| Outer panels | stainless steel | | | |
| Capacity per cycle | Liters | 3 | Gal | 0,79 |
| Max hourly production | Liters | 18 | Gal | 4,8 |
| Min. mix per cycle | Kg | 1,5 | lbs | 3,3 |
| Max. mix per cycle | Kg | 2,5 | lbs | 5,5 |
| Volume cylinder with mixer | Liters | 5,7 | Quarts | 6 |
| Volume cylinder without mixer | Liters | 6,1 | Quarts | 6,5 |
| Min. mixer speed | RPM 122 | | | |
| Max. mixer speed | RPM 250 | | | |
| Max power | kw | 5,2 | Hp | 7 |
| Voltage | 230 Volt/60Hz/3 phase | | | |
| Running Amps | Amp 17,7 | | | |
| Breaker size | Amp 30 | | | |
| Stirrer motor | kw | 0,22 | Hp | 0,3 |
| Drive motor | kw | 1,1 | Hp | 1,5 |
| Compressor power | kw | 1,2 | Hp | 1,6 |
| Compressor power | BTU/h 3200 | | | |
| Freon R404A | Gr | 1400 | Oz | 49,4 |
| Refrigeration condensation | Air | | | |
| Crate dimensions | cm | 100x63x105 | inches | 39,4x24,8x41,3 |
| Crate weight | kg | 170 | lbs | 375 |



Warranty: valid for the North American Continent (Canada, USA)
Extension: 12 months parts (with check list and warranty signed and mailed)
5 years compressor with registration on warranty.bravonorthamerica.com



Bravo North America Inc. Office & Showroom, 810 Tyvola Road, Suite 130, Charlotte, NC 28217
tel. +1 980 237 2474 bravonorthamerica.com info@bravonorthamerica.com

Trittico M 30

combi machine for gelato & ice cream
hot process production
water cooled

Model:
Quantity:
Project:
Company:
Contact:
Dealer ID:

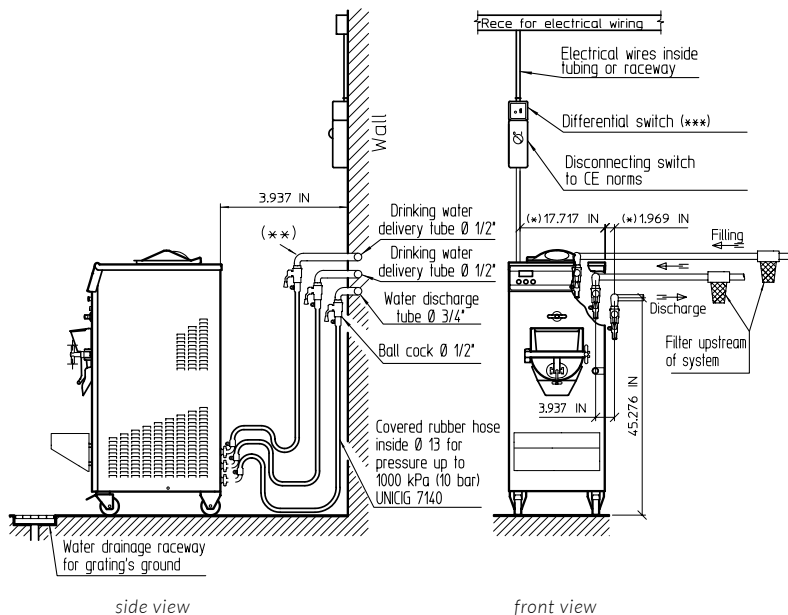
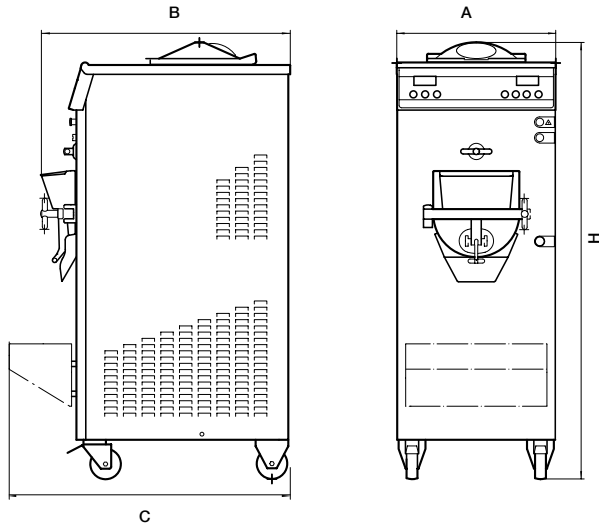

(*) Even if the machine models vary, the water and electricity connection positions are always the same, i.e. on the LEFT side of the machine.
(**) Cocks are in vertical only for illustration purposes.
(***) 30 mA (ABB serie C).



Warranty: valid for the North American Continent (Canada, USA)
Extension: 12 months parts (with check list and warranty signed and mailed)
5 years compressor with registration on warranty.bravonorthamerica.com

| | | | | |
|-------------------------------|----------------------------|-----------|--------|----------------|
| Width (A) | cm | 51 | inches | 20,1 |
| Depth (B) | cm | 80 | inches | 31,5 |
| Depth with base (C) | cm | 87,5 | inches | 34,4 |
| Height (H) | cm | 140 | inches | 55,1 |
| Weight | kg | 240 | lbs | 529 |
| Frame type | floor model | | | |
| Outer panels | stainless steel | | | |
| Capacity per cycle | Liters | 5 | Gal | 1,32 |
| Max. hourly production | Liters | 30 | Gal | 7,92 |
| Min. mix per cycle | Kg | 2 | Lbs | 4,4 |
| Max. mix per cycle | Kg | 4 | Lbs | 8,8 |
| Volume cylinder with mixer | Liters | 8,93 | Quarts | 9,43 |
| Volume cylinder without mixer | Liters | 9,46 | Quarts | 10 |
| Min. mixer speed | RPM 122 | | | |
| Max. mixer speed | RPM 250 | | | |
| Max power | kw | 5,8 | Hp | 7,7 |
| Voltage | 230 Volt / 60 Hz / 3 phase | | | |
| Running Amps | Amp 19,4 | | | |
| Breaker size | Amp 30 | | | |
| Stirrer motor | kw | 0,22 | Hp | 0,3 |
| Drive motor | kw | 2,2 - 1,5 | Hp | 3 - 2 |
| Compressor power | kw | 1,3 | Hp | 1,75 |
| Compressor power | BTU/h 4688 | | | |
| Freon R404A | Gr | 1150 | Oz | 40,5 |
| Refrigeration condensation | Water | | | |
| Water connection | cm | 1,27 | inches | 1/2 |
| Min. water pressure | bar | 1,5 | psi | 20 |
| Max. water pressure | bar | 3 | psi | 40 |
| Crate dimensions | cm | 97x69x172 | inches | 38,1x27,1x67,7 |
| Crate weight | kg | 308 | lbs | 679 |



Bravo North America Inc. Office & Showroom, 810 Tyvola Road, Suite 130, Charlotte, NC 28217
tel. +1 980 237 2474 bravonorthamerica.com info@bravonorthamerica.com

Trittico M 30

combi machine for gelato & ice cream
hot process production
air cooled

Model:
Quantity:
Project:
Company:
Contact:
Dealer ID:

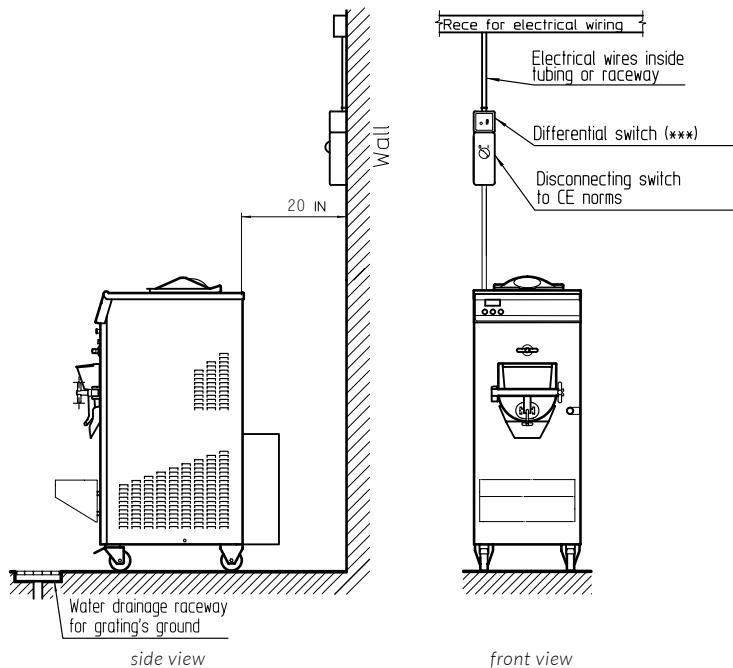
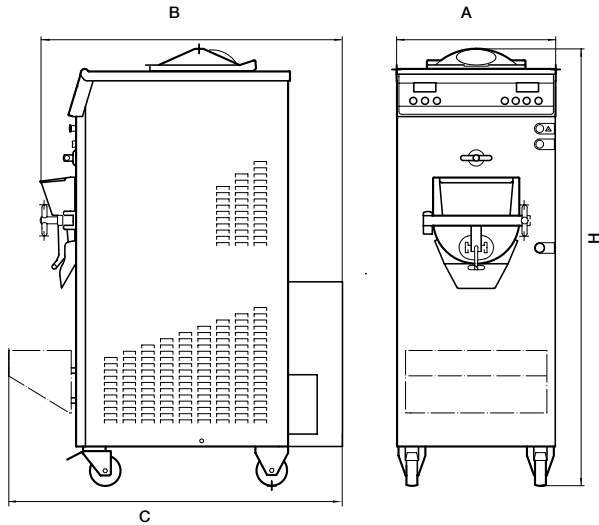

(**) 30 mA (ABB serie C).

| | | | | |
|-------------------------------|----------------------------|------------|--------|----------------|
| Width (A) | cm | 51 | inches | 20,1 |
| Depth (B) | cm | 97 | inches | 38,2 |
| Depth with base (C) | cm | 103,5 | inches | 40,7 |
| Height (H) | cm | 140 | inches | 55,1 |
| Weight | kg | 240 | lbs | 529 |
| Frame type | floor model | | | |
| Outer panels | stainless steel | | | |
| Capacity per cycle | Liters | 5 | Gal | 1,32 |
| Max. hourly production | Liters | 30 | Gal | 7,92 |
| Min. mix per cycle | Kg | 2 | Lbs | 4,4 |
| Max. mix per cycle | Kg | 4 | Lbs | 8,8 |
| Volume cylinder with mixer | Liters | 8,93 | Quarts | 9,43 |
| Volume cylinder without mixer | Liters | 9,46 | Quarts | 10 |
| Min. mixer speed | RPM 122 | | | |
| Max. mixer speed | RPM 250 | | | |
| Max power | kw | 5,8 | Hp | 7,7 |
| Voltage | 230 Volt / 60 Hz / 3 phase | | | |
| Running Amps | Amp 19,4 | | | |
| Breaker size | Amp 30 | | | |
| Stirrer motor | kw | 0,22 | Hp | 0,3 |
| Drive motor | kw | 2,2 - 1,5 | Hp | 3 - 2 |
| Compressor power | kw | 1,3 | Hp | 1,75 |
| Compressor power | BTU/h 4688 | | | |
| Freon R404A | Gr | 2100 | Oz | 74,1 |
| Refrigeration condensation | Air | | | |
| Crate dimensions | cm | 109x69x172 | inches | 42,9x27,1x67,7 |
| Crate weight | kg | 330 | lbs | 727 |



Warranty: valid for the North American Continent (Canada, USA)
Extension: 12 months parts (with check list and warranty signed and mailed)
5 years compressor with registration on warranty.bravonorthamerica.com



Bravo North America Inc. Office & Showroom, 810 Tyvola Road, Suite 130, Charlotte, NC 28217
tel. +1 980 237 2474 bravonorthamerica.com info@bravonorthamerica.com

Trittico M 50

combi machine for gelato & ice cream
hot process production
water cooled

Model:
Quantity:
Project:
Company:
Contact:
Dealer ID:

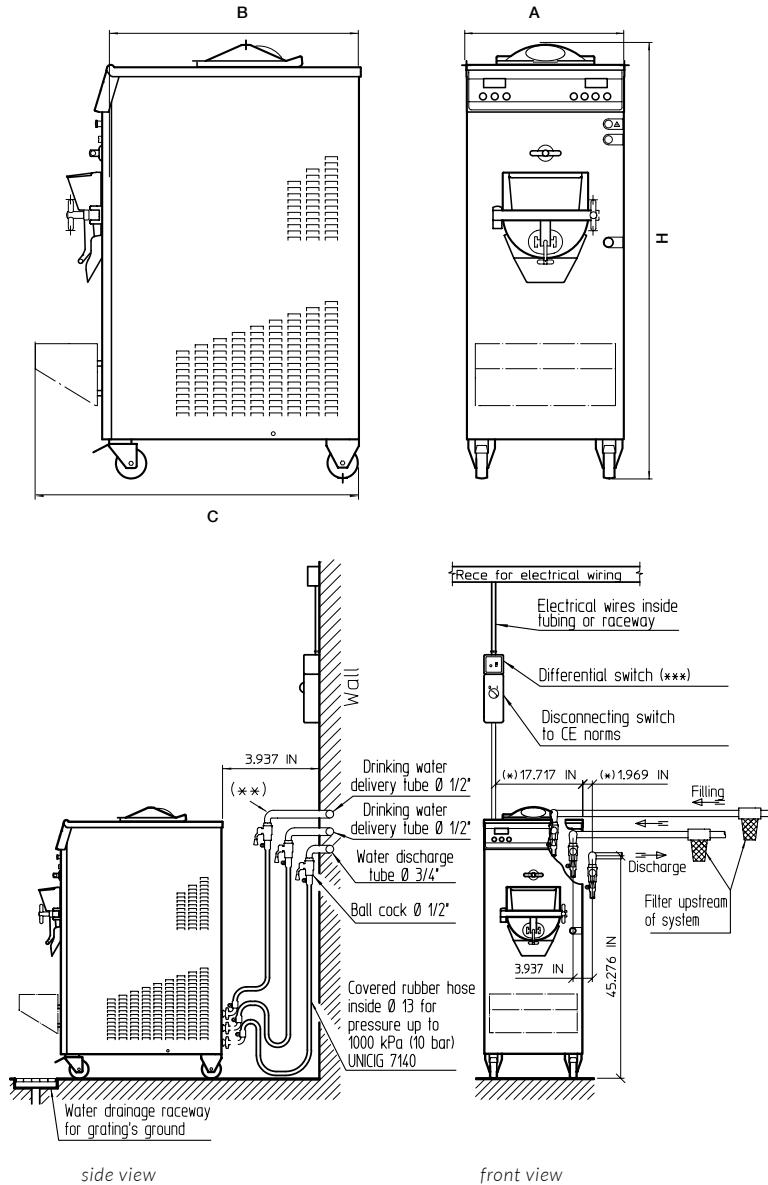

(*) Even if the machine models vary, the water and electricity connection positions are always the same, i.e. on the LEFT side of the machine.
(**) Cocks are in vertical only for illustration purposes.
(***) 30 mA (ABB serie C).



Warranty: valid for the North American Continent (Canada, USA)
Extension: 12 months parts (with check list and warranty signed and mailed)
5 years compressor with registration on warranty.bravonorthamerica.com

| | | | | |
|-------------------------------|-----------------------|------------|--------|----------------|
| Width (A) | cm | 51 | inches | 20,1 |
| Depth (B) | cm | 95 | inches | 37,4 |
| Depth with base (C) | cm | 102,5 | inches | 40,4 |
| Height (H) | cm | 140 | inches | 55,1 |
| Weight | kg | 295 | lbs | 642 |
| Frame type | floor model | | | |
| Outer panels | stainless steel | | | |
| Capacity per cycle | Liters | 7 | Gal | 1,84 |
| Max hourly production | Liters | 45 | Gal | 11,88 |
| Min. mix per cycle | Kg | 2,5 | lbs | 5,5 |
| Max. mix per cycle | Kg | 5,5 | lbs | 12,1 |
| Volume cylinder with mixer | Liters | 11,78 | Quarts | 12,45 |
| Volume cylinder without mixer | Liters | 12,42 | Quarts | 13,12 |
| Min. mixer speed | RPM 122 | | | |
| Max. mixer speed | RPM 250 | | | |
| Max power | kw | 6,2 | Hp | 8,3 |
| Voltage | 230 Volt/60Hz/3 phase | | | |
| Running Amps | Amp 21 | | | |
| Breaker size | Amp 30 | | | |
| Stirrer motor | kw | 0,22 | Hp | 0,3 |
| Drive motor | kw | 3,3 - 2,2 | Hp | 4,5 - 3 |
| Compressor power | kw | 2,8 | Hp | 3,75 |
| Compressor power | BTU/h 9349 | | | |
| Freon R404A | Gr | 1200 | Oz | 42 |
| Refrigeration condensation | Water | | | |
| Water connection Npt | cm | 1,27 | inches | 1/2 |
| Min. water pressure | bar | 1,5 | Psi | 20 |
| Max. water pressure | bar | 3 | Psi | 40 |
| Crate dimensions | cm | 110x63x167 | inches | 43,3x27,1x65,7 |
| Crate weight | kg | 360 | lbs | 793 |



Bravo North America Inc. Office & Showroom, 810 Tyvola Road, Suite 130, Charlotte, NC 28217
tel. +1 980 237 2474 bravonorthamerica.com info@bravonorthamerica.com

Trittico M 50

combi machine for gelato & ice cream
hot process production
air cooled

Model:
Quantity:
Project:
Company:
Contact:
Dealer ID:

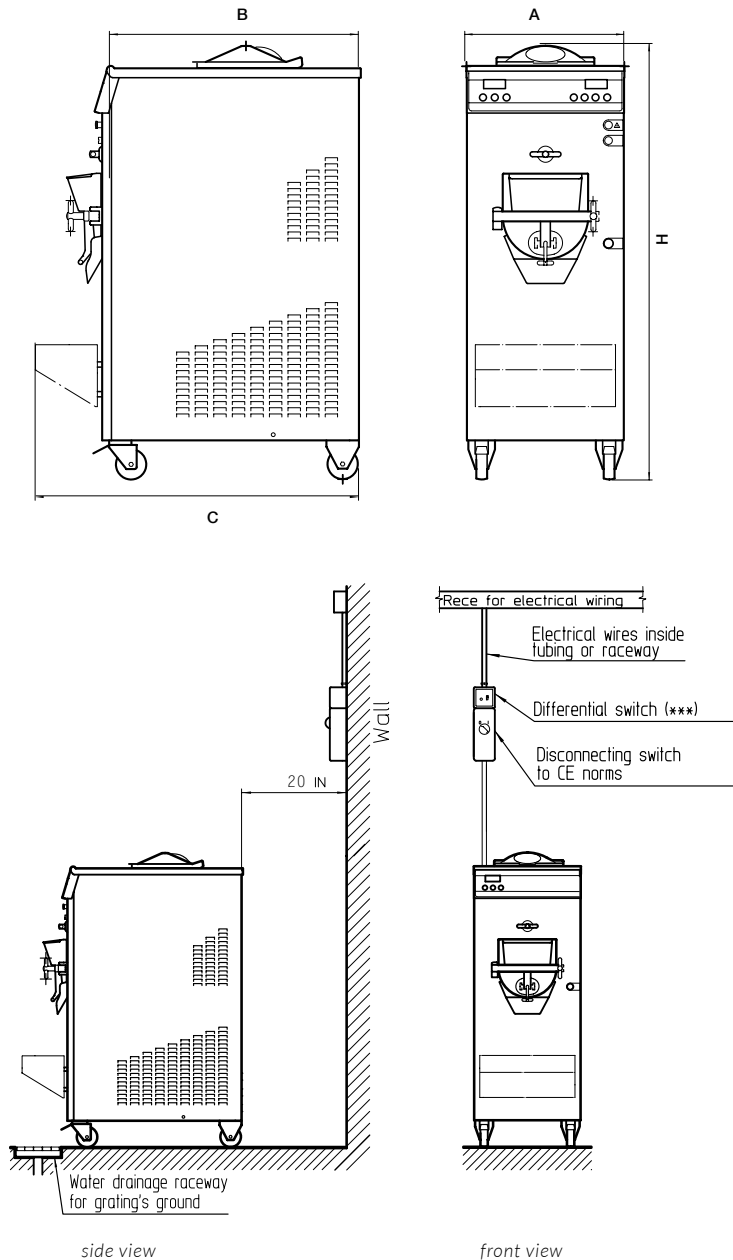

(**) 30 mA (ABB serie C).



Intertek Intertek

Warranty: valid for the North American Continent (Canada, USA)
Extension: 12 months parts (with check list and warranty signed and mailed)
5 years compressor with registration on warranty.bravonorthamerica.com

| | | | | |
|-------------------------------|-----------------------|------------|--------|----------------|
| Width (A) | cm | 61 | inches | 24 |
| Depth (B) | cm | 95 | inches | 37,4 |
| Depth with base (C) | cm | 102,5 | inches | 40,4 |
| Height (H) | cm | 140 | inches | 55,1 |
| Weight | kg | 295 | lbs | 642 |
| Frame type | floor model | | | |
| Outer panels | stainless steel | | | |
| Capacity per cycle | Liters | 7 | Gal | 1,84 |
| Max hourly production | Liters | 45 | Gal | 11,88 |
| Min. mix per cycle | Kg | 2,5 | lbs | 5,5 |
| Max. mix per cycle | Kg | 5,5 | lbs | 12,1 |
| Volume cylinder with mixer | Liters | 11,78 | Quarts | 12,45 |
| Volume cylinder without mixer | Liters | 12,42 | Quarts | 13,12 |
| Min. mixer speed | RPM 122 | | | |
| Max. mixer speed | RPM 250 | | | |
| Max power | kw | 6,2 | Hp | 8,3 |
| Voltage | 230 Volt/60Hz/3 phase | | | |
| Running Amps | Amp 21 | | | |
| Breaker size | Amp 30 | | | |
| Stirrer motor | kw | 0,22 | Hp | 0,3 |
| Drive motor | kw | 3,3 - 2,2 | Hp | 4,5 - 3 |
| Compressor power | kw | 2,8 | Hp | 3,75 |
| Compressor power | BTU/h 9349 | | | |
| Freon R404A | Gr | 3000 | Oz | 105 |
| Refrigeration condensation | Air | | | |
| Crate dimensions | cm | 110x69x167 | inches | 43,3x27,1x65,7 |
| Crate weight | kg | 375 | lbs | 826 |



Bravo North America Inc. Office & Showroom, 810 Tyvola Road, Suite 130, Charlotte, NC 28217
tel. +1 980 237 2474 bravonorthamerica.com info@bravonorthamerica.com

Trittico M 60

combi machine for gelato & ice cream
hot process production
water cooled

Model:
Quantity:
Project:
Company:
Contact:
Dealer ID:

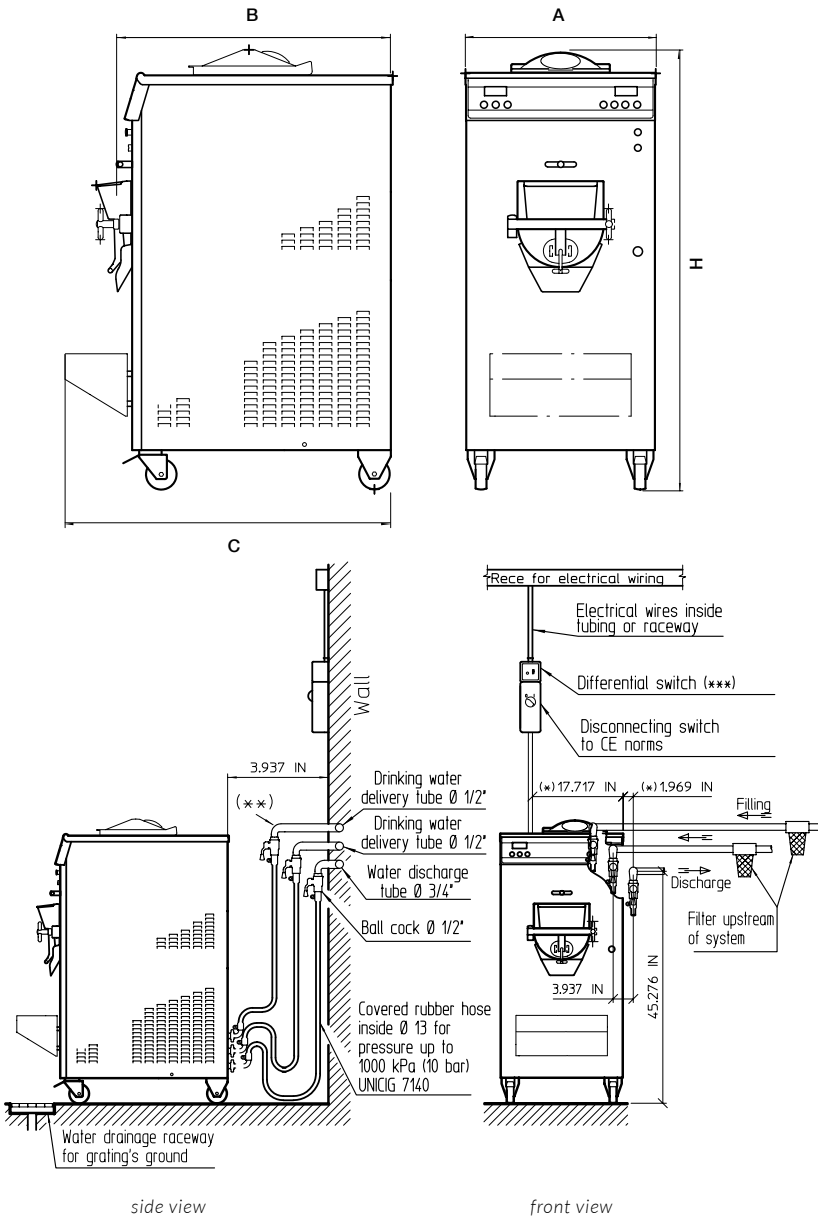

(*) Even if the machine models vary, the water and electricity connection positions are always the same, i.e. on the LEFT side of the machine.
(**) Cocks are in vertical only for illustration purposes.
(***) 30 mA (ABB serie C).



Warranty: valid for the North American Continent (Canada, USA)
Extension: 12 months parts (with check list and warranty signed and mailed)
5 years compressor with registration on warranty.bravonorthamerica.com

| | | | | |
|-------------------------------|-----------------------|------------|--------|--------------|
| Width (A) | cm | 61 | inches | 24 |
| Depth (B) | cm | 95 | inches | 37,4 |
| Depth with base (C) | cm | 102,5 | inches | 40,4 |
| Height (H) | cm | 141 | inches | 55,5 |
| Weight | kg | 329 | lbs | 725 |
| Frame type | floor model | | | |
| Outer panels | stainless steel | | | |
| Capacity per cycle | Liters | 10 | Gal | 2,64 |
| Max hourly production | Liters | 60 | Gal | 15,85 |
| Min. mix per cycle | Kg | 4 | lbs | 8,8 |
| Max. mix per cycle | Kg | 8 | lbs | 17,6 |
| Volume cylinder with mixer | Liters | 15,83 | Quarts | 16,73 |
| Volume cylinder without mixer | Liters | 16,64 | Quarts | 17,58 |
| Min. mixer speed | RPM 122 | | | |
| Max. mixer speed | RPM 250 | | | |
| Max power | kw | 9 | Hp | 11,9 |
| Voltage | 230 Volt/60Hz/3 phase | | | |
| Running Amps | Amp 30,1 | | | |
| Breaker size | Amp 60 | | | |
| Stirrer motor | kw | 0,22 | Hp | 0,3 |
| Drive motor | kw | 4,0 - 2,6 | Hp | 5,4 - 3,5 |
| Compressor power | kw | 2,8 | Hp | 3,75 |
| Compressor power | BTU/h 9349 | | | |
| Freon R404A | Gr | 2000 | Oz | 70,5 |
| Refrigeration condensation | Water | | | |
| Water connection Npt | cm | 1,27 | inches | 1/2 |
| Min. water pressure | bar | 1,5 | Psi | 20 |
| Max. water pressure | bar | 3 | Psi | 40 |
| Crate dimensions | cm | 110X80X172 | inches | 43x31,9x67,7 |
| Crate weight | kg | 410 | lbs | 904 |



Bravo North America Inc. Office & Showroom, 810 Tyvola Road, Suite 130, Charlotte, NC 28217
tel. +1 980 237 2474 bravonorthamerica.com info@bravonorthamerica.com

Trittico M 120

combi machine for gelato & ice cream
hot process production
water cooled

Model:
Quantity:
Project:
Company:
Contact:
Dealer ID:

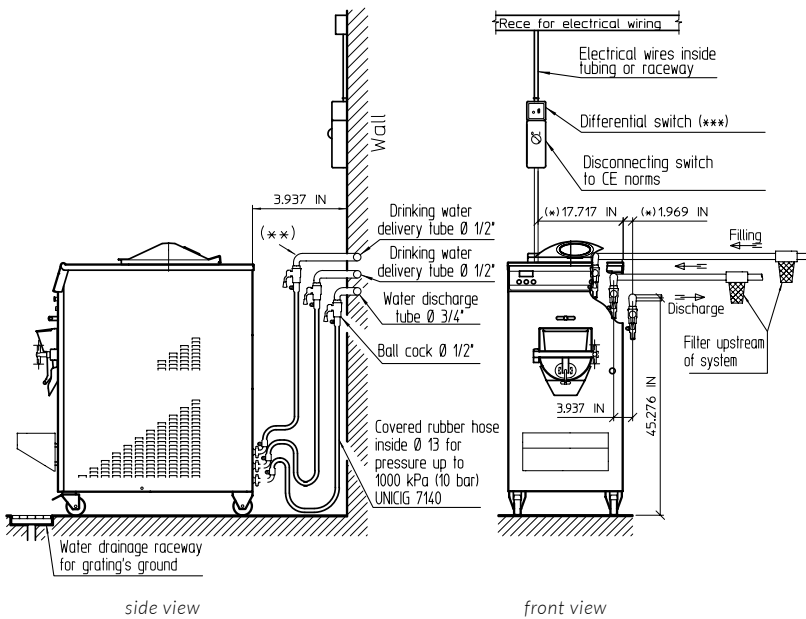
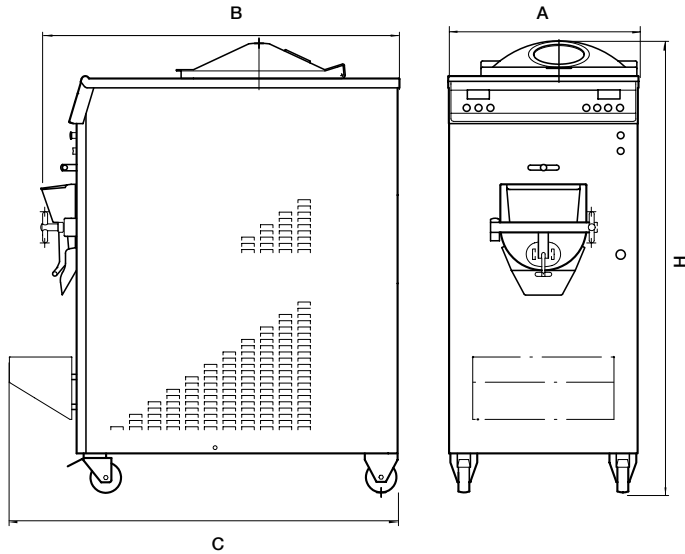

(*) Even if the machine models vary, the water and electricity connection positions are always the same, i.e. on the LEFT side of the machine.
(**) Cocks are in vertical only for illustration purposes.
(***) 30 mA (ABB serie C).



Warranty: valid for the North American Continent (Canada, USA)
Extension: 12 months parts (with check list and warranty signed and mailed)
5 years compressor with registration on bravonorthamerica.com/warranty

| | | | | |
|-------------------------------|-----------------------|------------|--------|--------------|
| Width (A) | cm | 61 | inches | 24 |
| Depth (B) | cm | 115 | inches | 45,3 |
| Depth with base (C) | cm | 122,5 | inches | 48,2 |
| Height (H) | cm | 144 | inches | 56,7 |
| Weight | kg | 451 | lbs | 994 |
| Frame type | floor model | | | |
| Outer panels | stainless steel | | | |
| Capacity per cycle | Liters | 20 | Gal | 5,28 |
| Max hourly production | Liters | 120 | Gal | 31,7 |
| Min. mix per cycle | Kg | 8 | lbs | 17,6 |
| Max. mix per cycle | Kg | 16 | lbs | 35,3 |
| Volume cylinder with mixer | Liters | 26,05 | Quarts | 27,53 |
| Volume cylinder without mixer | Liters | 27,63 | Quarts | 29,2 |
| Min. mixer speed | RPM 122 | | | |
| Max. mixer speed | RPM 250 | | | |
| Max power | kw | 18,6 | Hp | 24,6 |
| Voltage | 230 Volt/60Hz/3 phase | | | |
| Running Amps | Amp 61,2 | | | |
| Breaker size | Amp 100 | | | |
| Stirrer motor | kw | 0,45 | Hp | 0,6 |
| Drive motor | kw | 7,5 - 4,8 | Hp | 10 - 6,4 |
| Compressor power | kw | 5,5 | Hp | 7,4 |
| Compressor power | BTU/h 13624 | | | |
| Freon R404A | Gr | 3000 | Oz | 105,8 |
| Refrigeration condensation | Water | | | |
| Water connection Npt | cm | 1,27 | inches | 1/2 |
| Min. water pressure | bar | 1,5 | Psi | 20 |
| Max. water pressure | bar | 3 | Psi | 40 |
| Crate dimensions | cm | 132X78X187 | inches | 51x30,7x73,6 |
| Crate weight | kg | 590 | lbs | 1300 |



Bravo North America Inc. Office & Showroom, 810 Tyvola Road, Suite 130, Charlotte, NC 28217
tel. +1 980 237 2474 bravonorthamerica.com info@bravonorthamerica.com