

# ecoline-A

high performance-cost effective  
above ground oil water separation

**FREYTECH** INC.

ecoline

Version 1.3.2.20

# Highly efficient and cost saving oil/water separation is today's challenge.

## ecoLine-a is our answer

Small facilities are frequently hot spots when it comes to treatment of hydro-carbon laden waste-water. The total amount of wastewater generated per day is sometimes too small to justify construction cost for the installation of a below grade oil/water separator.

For these applications, an above grade unit provides an acceptable solution. The ecoLine-a Oil/Water Separator provides the first substantial cost savings in the form of zero construction site labor.

ecoLine-a is equipped with a removable top panel. This provides full access to all basic elements of the ecoLine-a system. Routine cleaning and maintenance are then efficient and cost effective. Annual maintenance cost savings range from 30% to 50% lower than that of conventional separator systems.

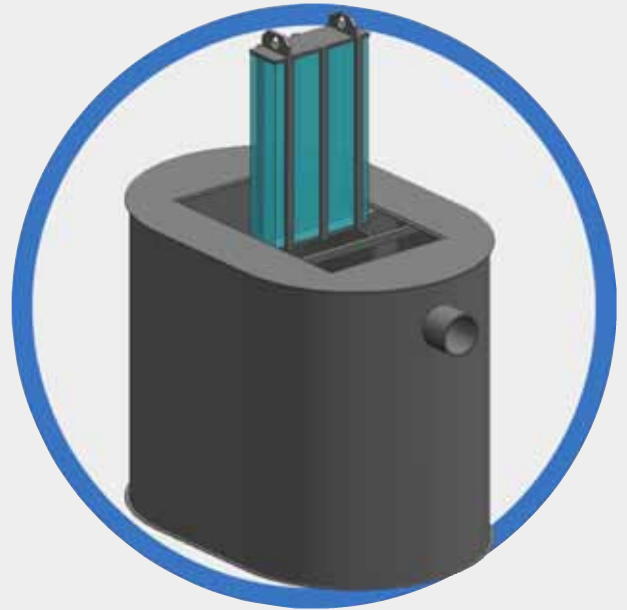

# Today's environmental legislation is hard enough to comply with.

## ecoLine-a meets tomorrow's standards today

It's not just the ecoLine's long maintenance intervals and low waste-disposal costs that make it such a good investment, but the fact that it is designed with future standards in mind. The ecoLine-a far exceeds the strict European standards (DIN1999 and EN858) for performance (less than 5ppm of free oil). The outstanding independent testing certificates demonstrate that ecoLine-a will provide clean water that exceeds today's environmental standards. ecoLine-a also allows for tighter, future environmental discharge compliance guidelines to be met with little or no modification to the system. ecoLine-a combines high efficiency oil/water separation with mobile flexibility. Specially designed coalescing media panels provide a large specific surface to support the separation of small oil droplets. If your oil separation application is variable with numerous holding tanks in various locations or space is too limited for a below grade unit, consider ecoLine-a as your above grade oil/water separator.

## Working Principle

The ecoLine-a oil/water separator is designed to separate non-emulsified light liquids or low-water-soluble fluids with a specific gravity below 0.95 (gasoline, diesel, heating oils and other mineral oils) from effluent discharge. A two-step separation process, gravity separation and removal of small oil particles by coalescing media elements, produce high removal efficiencies.

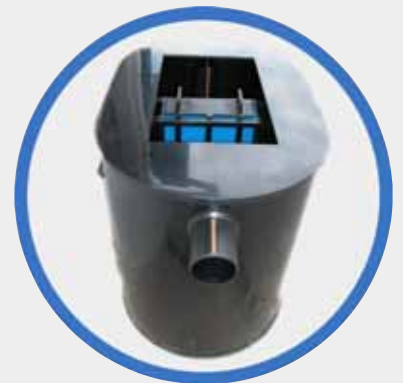

### Purification Step 1: Gravity Separation

The sediment and solids, pre-treated run-off is gravity fed or pumped (typically with a positive displacement or diaphragm type pump) to the gravity separator through a submerged inlet pipe. The separation process relies on the fact, that light fluids have a lower specific gravity than water and thus float on the water surface.

### Purification Step 2: Coalescing Media

In the residual oil media, fine droplets, that are too small to be separated by gravity alone are accumulated into bigger drops that rise to the surface. This coalescing media is made of reticular (i.e. „net-like“) soft polyurethane foam. The media-cartridge is very easy to lift out and reinstall once it is cleaned/rinsed with a garden hose.

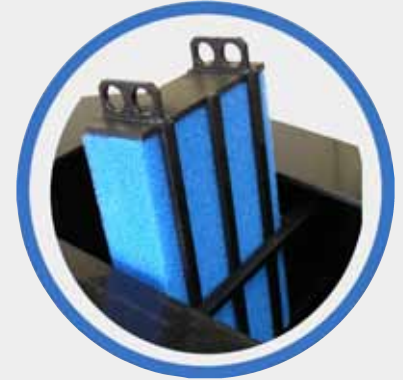

## ecoLine-a Model Sizes



ecoLine-a offers a full range of above ground oil water separators. The following models are available:

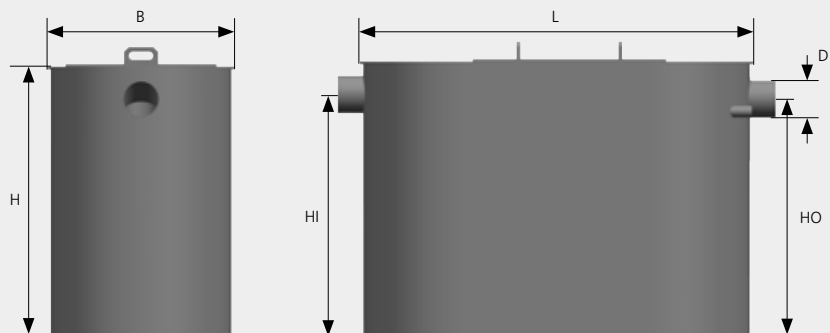

Item no.	Item	Flow rate		D		L		B		H		HI		HO		Weight W	
		[l/s]	[gpm]	[mm]	[in]	[mm]	[in]	[mm]	[in]	[mm]	[in]	[mm]	[in]	[mm]	[in]	[kg]	[lb]
101915	ecoLine-a NS1.5	1,5	25	110	4.3	1236	49.4	716	28.6	800	32.0	695	27.8	675	27.0	40	88
101974	ecoLine-a NS03	3,0	50	110	4.3	1480	59.2	770	30.8	1052	42.1	915	36.6	895	35.8	70	154
101962	ecoLine-a NS06	6,0	100	160	6.4	1720	68.8	820	32.8	1182	47.3	1040	41.6	1020	40.8	100	220
103301	ecoLine-a NS12	12	200	200	8.0	2400	96.0	1220	48.8	1520	60.8	1130	45.2	1110	44.4	300	660
103002	ecoLine-a NS20	20	318	250	10.0	2740	109.6	1620	64.8	1700	68.0	1360	54.4	1340	53.6	480	1058
102061	ecoLine-a NS40	40	636	315	12.6	3030	121.2	1920	76.8	2030	81.2	1670	66.8	1650	66.0	800	1763

Approximate dimensions. For installation purposes, please refer to our product drawings.



# Operation and Maintenance

## Installation:

The separator must be installed above grade and leveled on a solid surface. The chosen location for the system should be as close as possible to the source of waste stream to be treated. When choosing the location, make sure that the separator can easily be accessed for maintenance. Avoid any pipes or hydraulic structures that may contribute or increase the amount of mechanically emulsified oil, upstream to the separator. When the influent holding vessel requires it to be pumped, only positive displacement, diaphragm or screw type pump should be employed to avoid extreme mechanical emulsification of oil-laden wastewater. The system is designed for use inside a building. Avoid high temperature or exposure to sunlight. Ensure proper venting of the system.

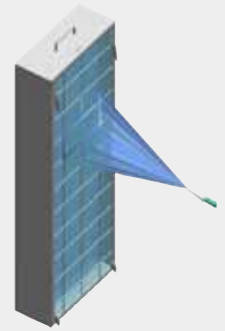

## Maintenance:

The coalescing media cartridge has to be cleaned periodically. Since the maintenance intervals strongly depend on the very application, check the condition of the filter element weekly during the first 60 days of operation. The filter media can be cleaned/rinsed with a garden hose. Recycle the wash-water to the separator.

Over time, UV radiation and sun light will degrade the coalescing media. It is, therefore, strongly recommended that the media inside the cartridges not be left outdoors for extended periods of time after cleaning. Some exposure to UV radiation and sunlight will not harm the system. Remove sludge and oil from the system periodically.

## Removal of accumulated oil:

### Manual oil draw-off device:

The standard version of the ecoLine-a oil/water separator is equipped with an opening (3/4" external thread) to connect a hose and valve. The manual oil draw-off can only be operated during non-operational periods (no influent entering the separator). the accumulated oil can be drained into an external oil drum (not provided).



### Automatic oil draw-off device:

As an option the ecoLine-a can be ordered with an automatic oil draw-off device. This built in ADD mechanically removes accumulated light liquids 24/7 from the water surface and stores them in an external oil recipient or oil drum. The collected oil is free of any water (99.7% pure).

For further information about the automatic oil draw-off, please see our O&M manual for the ADD HDPE.



### Temperature range of operation:

41 to 122°F (5°C to 50°C) - permanent temperature  
Systems for higher temperatures available upon request

**Material:** High grade polyethylene

## Freytech Inc.

1111 Brickell Avenue, Suite 1550, Miami, Florida 33131, USA  
Phone.: +1 (305) 372-1104 Fax: +1 (305) 328-9312  
e-mail: info@freytech.com, www.freytech.com

**FREYTECH INC.**