

B34 Series Regulator

Commercial and Industrial Regulator

Applications

Appropriate for many commercial and industrial uses such as gas engines, burners, furnaces and boilers. The rapid response of the B34 is particularly well-suited for mid-range applications where quick on/off loads cause shock problems.

Model Description

- > B34N – The B34N is a spring loaded self-operated regulator with no internal relief, an adjustable loading ring for controlled boost at higher flows, and a precision breather opening to ensure proper stability for all conditions. This regulator can be used on low or intermediate inlet pressures where an internal relief or other type of over-pressure protection device is not required.
- > B34R – The B34R is the internal relief version of the B34 series. This model features an adjustable loading ring for controlled boost at higher flows and a 1" internal relief valve.
- > B34DN – The B34DN is a standard B34N with a closed throat, downstream control tap on the bottom of the diaphragm case, and no internal relief capabilities. This unit is used when it is desirable to control the regulator from points other than the valve outlet. Since the control point is no longer at the outlet of the valve body the regulator does not boost, but all the capacity tables are the same as the R and N models.
- > B34DR – The B34DR is the same as the B34DN, except it has internal relief similar to the B34R.
- > B34MN – The B34MN is very similar to the B34DN with a closed throat, downstream control line and no internal relief capabilities, except for an O-ring seal on the valve body stem through the throat to assure positive downstream control when installed ahead of a downstream regulator. Used in a series monitoring installation as the upstream regulator, this unit gives customers an operating device that assumes control over an operating regulator when failure is sensed by the control line of the monitor. This series system assures maximum safety with uninterrupted service. The monitor regulator is set to take over control from the operating regulator with only a slight increase in outlet pressure.

- > B34MR – The B34MR is the same as the B34MN, except it has internal relief similar to the B34R.

Features

- > Interchangeable brass orifice
- > 78 in² of diaphragm area
- > Spring-loaded internal relief valve assembly
- > Field interchangeable adjustment spring
- > Controlled size breather orifice eliminates pulsation and provides normal action at low flows
- > Wide range of valve body sizes including NPT and flange connections

Benefits

- > Economical
- > Protects equipment from shock damage
- > Large 12" diaphragm for better outlet pressure control
- > Unmatched overpressure protection with internal monitor (IM) plus internal relief option



Shipping weight

One regulator per box Box weight: 24 lbs.

B34 Dimensions (inches)

Valve Body	A	B	C	D	E	F	G	H	R
1-1/4, 1/1/2, or 2 NPT	5-3/4	2-7/8	8-11/16	12-3/4	4-5/16	10	2-3/16	4-1/2	2-1/4
2 Flanged	10	5	8-11/16	12-3/4	4-5/16	10	2-3/16	5-1/2	3-1/4
3 Flanged	10	5	8-11/16	12-3/4	4-5/16	10	2-3/16	5-1/2	3-1/4

B34 IM Dimensions (inches)

Valve Body	A	B	C	D	E	F	G	H	R
1-1/4, 1/1/2, or 2 NPT	5-3/4	2-7/8	8-11/16	12-3/4	4-5/16	10	2-3/16	5	2-1/4
2 Flanged	10	5	8-11/16	12-3/4	4-5/16	10	2-3/16	5-1/2	3-1/4
3 Flanged	10	5	8-11/16	12-3/4	4-5/16	10	2-3/16	6-1/4	4

► Screwed Valve Body

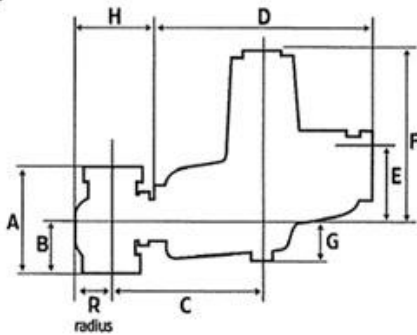

► Flanged Valve Body

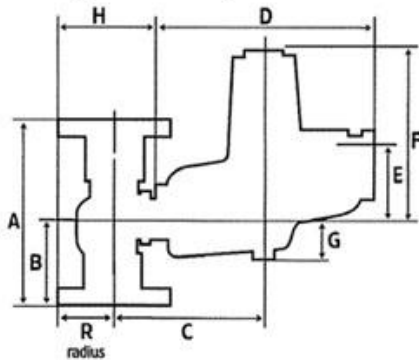

Spring Data - Spring Color Outlet Pressure Range

Colors	Outlet Pressure Range
Orange	3.0" w.c. - 5.0" w.c.
Brown	4.0" w.c. - 6.5" w.c.
Green	5.0" w.c. - 8.0" w.c.
Black	6.5" w.c. - 13.0" w.c.
Purple	9.1" w.c. - 20.8" w.c.
Blue	15.0" w.c. - 28.0" w.c.
Silver	1.0 PSIG – 2.0 PSIG
Yellow	2.0 PSIG - 4.5 PSIG
Red-nested	4.0 PSIG - 5.5 PSIG
White-nested	4.8 PSIG - 7.3 PSIG

Orifice Data - Wide Open Flow Coefficients and Maximum Pressures

Orifice Size (inches)	K-Factor	Maximum Operating Inlet (PSIG)			Maximum Emergency Inlet Pressure (PSIG)	Maximum Emergency Outlet Pressure (PSIG)
		In. w.c. Delivery N & R Models	In. w.c. Delivery D & M Models	PSIG Delivery All Models	All Deliveries All Models	All Deliveries All Models
1/4	125	125	175	175	300	60
1/4 x 3/8	125	125	125	175	300	
3/8	290	125	125	175	300	
3/8 x 1/2	305	125	125	150	300	
1/2	500	75	125	150	300	
1/2 x 5/8	550	60	125	150	300	
5/8	700	60	125	150	300	
5/8 x 3/4	750	60	100	150	300	
3/4	900	60	100	150	300	
3/4 x 7/8	950	60	100	150	230	
7/8	1200	60	100	150	230	
7/8 x 1	1245	25	100	150	230	

B34 IM Maximum Inlet Pressure Data

Orifice Size (inches)	Max. Inlet Pressure	
	w.c. Outlet	PSIG Outlet
3/4	60	150
5/8	60	150
1/2	75	150
3/8	125	150

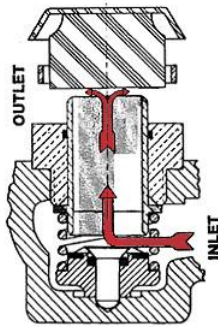

B34 IM Spring Data

Spring Color	Brown (in. w.c.)	Green/White (in. w.c.)	Black (in. w.c.)	Purple (in. w.c.)	Blue (in. w.c.)	Silver/Red (PSIG)	Yellow (PSIG)	Red (PSIG)
Outlet Pressure Range	4.5 - 5.5	5.5 - 7.2	7.2 - 13.5	13.0 - 20.0	15.0 - 28.0	0.8 - 2.2	0.5 - 4.4	1.8 - 5.8

B34 IMRV

Main Spring Color	Outlet Pressure Set	Maximum Downstream Pressure Buildup B34IMRV			
		B34IMR & B34IMN	Standard Relief Spring	Brown Relief Spring	Green Relief Spring
Brown	5.5" w.c.	10.5" w.c.	13.0" w.c.	-	-
Green/White	7.0" w.c.	11.5" w.c.	14.5" w.c.	-	-
Black	11.0" w.c.	16.0" w.c.	20.0" w.c.	-	-
Purple	14.0" w.c.	23.0" w.c.	28.0" w.c.	-	-
Blue	20.0" w.c.	26.0" w.c.	30.0" w.c.	-	-
Silver/Red	1 PSIG	1.4 PSIG	1.5 PSIG	2.0 PSIG	-
Silver	2 PSIG	2.5 PSIG	2.6 PSIG	3.2 PSIG	-
Yellow	3 PSIG	3.7 PSIG	3.9 PSIG	5.0 PSIG	6.4 PSIG
Red	5 PSIG	6.1 PSIG	6.6 PSIG	8.0 PSIG	8.9 PSIG

B34IMRV Flow Chart						
Vented gas flow, regulator seat failed; monitor seat closed						
Inlet Pressure PSIG	20	40	60	75	100	125
Flow SCFH	60	90	120	150	190	230

Operating Temperature Range

- -20°F to 150°F
- Silicone valve seats available for applications below -20°F

Additional Specifications

Available Vent Sizes:	1"
Loading Ring Position:	M & D models - 0°, R & N models for <1 PSIG set point - 21°; >1 PSIG set point - 0°
Other Available Options:	Seal wire to indicate unapproved tampering
	1/8" pipe plug tap on upstream side of valve body

Itron takes pride in delivering American made products with the utmost concern for safety, quality, and customer satisfaction.

Construction materials:

Valve body	High tensile strength cast iron
Orifice	Brass
Valve seat	Buna-N or silicone (for temperatures below -20°F)
Valve stem	Plated Steel
Lever pin	Stainless steel
Lever	Zinc and dichromate plated steel
Stem Guide	Stainless Steel
Upper diaphragm plate	Zinc and dichromate plated steel
Lower diaphragm plate	Die cast aluminum
Diaphragm	Buna-N and nylon
Vent valve/seat	Delrin/Buna-N
Vent screen	Stainless steel
Adjustment ferrule	Die cast aluminum
Seal cap	Die cast aluminum
Diaphragm case	Die cast aluminum

Valve Body Sizes (inches)

Inlet	Outlet	NPT	Flanged
1-1/4	1-1/4	X	---
1-1/4	1-1/2	X	---
1-1/4	2	X	---
1-1/2	1-1/2	X	---
1-1/2	2	X	---
2	2	X	X
3	3	---	X

Note: X indicates that the valve body is available in that configuration

B34IM Valve Body Sizes (inches)

Inlet	Outlet	NPT	Flanged
1-1/4	1-1/2	X	---
1-1/4	2	X	---
1-1/2	1-1/2	X	---
1-1/2	2	X	---
2	2	X	X
3	3	X*	X*

*With 2" bore

Note: X indicates that the valve body is available in that configuration

Correction factors for non-natural gas applications

The B34 may be used to control gases other than natural gas. To determine the capacity for gases other than natural gas, multiply the values within the capacity tables by a correction factor. The table below lists the correction factors for some of the more common gases:

Gas Type	Specific Gravity	Correction Factor (CF)
Air	1.00	0.77
Butane	2.01	0.55
Carbon Dioxide (Dry)	1.52	0.63
Carbon Monoxide (Dry)	0.97	0.79
Natural Gas	0.60	1.00
Nitrogen	0.97	0.79
Propane	1.53	0.63
Propane-Air-Mix	1.20	0.71

To calculate the correction factor for gases not listed in the table above, use the gases' specific gravity and insert it in the formula listed below:

$$\text{Correction Factor (CF)} = \sqrt{\frac{SG_1}{SG_2}}$$

Where:

SG₁ = Specific gravity of the gas in which the capacity is published.

SG₂ = Specific gravity of the gas to be controlled.

Wide Open Flow Calculations

For wide-open orifice flow calculations use the following equations:

$$\text{For } P_1/P_2 < 1.89 \text{ use: } Q = K\sqrt{P_2(P_1 - P_2)}$$

$$\text{For } P_1/P_2 > 1.89 \text{ use: } Q = \frac{KP_1}{2}$$

Where: P₁ = Absolute Inlet Pressure (PSIA)

P₂ = Absolute Outlet Pressure (PSIA)

Q = Flow Rate (SCFH)

K = Orifice Coefficient (SCFH/PSI)

B34 Series Commercial Regulator – Models N, R, M, and D 7" w.c. (17.5 mbar) Capacity Table (1" Droop*)

Capacities in SCFH of 0.6 S.G. gas; base conditions of 14.7 PSIA and 60° F.

Typical Capacity Info.	
Manufacturer	Itron
Type and model	B34R
Regulator	
Inlet size	2" NPT
Outlet size	2" NPT
Position	11

Inlet Pressure		Orifice Size				
PSIG	Bar	1/4"	1/4" x 3/8"	3/8"	3/8" x 1/2"	1/2"
8" w.c.	0.020					325 (9.1)
10" w.c.	0.025			325 (9.1)	435 (12.2)	500 (14.0)
12" w.c.	0.030		250 (7.0)	400 (11.2)	540 (15.1)	625 (17.5)
14" w.c.	0.035	225 (6.3)	300 (8.4)	475 (13.3)	610 (17.1)	750 (21.0)
16" w.c.	0.040	250 (7.0)	350 (9.8)	550 (15.4)	700 (19.6)	800 (22.4)
18" w.c.	0.045	275 (7.7)	375 (10.5)	600 (16.8)	740 (20.7)	900 (25.2)
21" w.c.	0.052	300 (8.4)	400 (11.2)	700 (19.6)	800 (22.4)	1050 (29.4)
24" w.c.	0.060	350 (9.8)	400 (11.2)	800 (22.4)	890 (24.9)	1200 (33.6)
1	0.069	400 (11.2)	400 (11.2)	875 (24.5)	1000 (28.0)	1300 (36.4)
2	0.138	575 (16.1)	575 (16.1)	1300 (36.4)	1500 (42.0)	1900 (53.2)
3	0.207	775 (21.7)	800 (22.4)	1700 (47.6)	2000 (56.0)	2000 (56.0)
5	0.345	1000 (28.0)	1100 (30.8)	2000 (56.0)	2400 (67.2)	2400 (67.2)
10	0.69	1500 (42.5)	1700 (47.6)	3400 (95.2)	3500 (98.0)	3500 (98.0)
20	1.38	2150 (60.2)	2300 (64.4)	5000 (140.0)	5000 (140.0)	8500 (238.0)
30	2.07	2750 (77.0)	2900 (81.2)	6500 (182.0)	6500 (182.0)	10000(280.0)
40	2.76	3450 (96.6)	3550 (99.4)	8000 (224.0)	8000 (224.0)	10000(280.0)
50	3.45	3800 (106.4)	4100 (114.8)	9200 (257.6)	9200 (257.6)	10000(280.0)
60	4.14	4500 (127.0)	5000 (140.0)	9500 (266.0)	10000 (280.0)	10000(280.0)
70	4.83	4700 (131.6)	5100 (142.8)	10000 (280.0)	10000 (280.0)	10000(280.0)
80	5.52	4900 (137.2)	6000 (169.9)	10000 (280.0)		
90	6.21	6800 (190.4)	7000 (196.0)	10000 (280.0)		
100	6.90	7400 (207.2)	7800 (218.4)	10000 (280.0)		
125	8.63	8800 (246.4)	9000 (252.0)	10000 (280.0)		

Inlet Effect ^A in. w.c. (mbar)	0.3 (0.8)	0.3 (0.8)	0.3 (0.8)	0.3 (0.8)	0.3 (0.8)
Lock Up ^B in.w.c. (mbar)	0.3 (0.8)	0.3 (0.8)	0.3 (0.8)	0.5 (1.3)	0.5 (1.3)

Notes:

*Individual regulator performance may vary from data shown.

A. Change in outlet pressure for 10 PSIG inlet pressure change.

B. Outlet pressure increase required for lock up.

 Inlet pressure is too low to deliver 7" w.c. (17.5 mbar).

 Do not operate orifice in shaded inlet pressure area.

7" w.c. (17.5 mbar) Capacity Table (1" Droop*) continued:

Capacities in SCFH of 0.6 S.G. gas; base conditions of 14.7 PSIA and 60° F.

Inlet Pressure		Orifice Size						
PSIG	Bar	1/2" x 5/8"	5/8"	5/8" x 3/4"	3/4"	3/4" x 7/8"	7/8"	7/8" x 1"
8" w.c.	0.020	400 (11.2)	500 (14.0)	635 (17.8)	675 (18.9)	725 (20.3)	850 (23.8)	900 (25.2)
10" w.c.	0.025	650 (18.2)	750 (21.0)	850 (23.8)	900 (25.2)	1050 (29.4)	1150 (32.2)	1225 (34.3)
12" w.c.	0.030	800 (22.4)	950 (26.6)	1050 (29.4)	1100 (30.8)	1250 (35.0)	1425 (39.9)	1550 (43.4)
14" w.c.	0.035	900 (25.2)	1175 (32.9)	1200 (33.6)	1250 (35.0)	1525 (42.7)	1700 (47.6)	1900 (53.2)
16" w.c.	0.040	1050 (29.4)	1175 (32.9)	1350 (37.8)	1550 (43.4)	1700 (47.6)	1950 (54.6)	2050 (57.4)
18" w.c.	0.045	1150 (32.2)	1275 (35.7)	1575 (44.1)	1750 (49.0)	1825 (51.1)	2050 (57.4)	2350 (65.8)
21" w.c.	0.052	1350 (37.8)	1500 (42.5)	1750 (49.0)	1800 (50.4)	2100 (58.8)	2350 (65.8)	2700 (75.6)
24" w.c.	0.060	1450 (40.6)	1700 (47.6)	1950 (54.6)	2100 (58.8)	2250 (63.0)	2700 (75.6)	3000 (84.0)
1	0.069	1500 (42.0)	2200 (61.6)	2200 (61.6)	2300 (64.4)	2400 (67.2)	2700 (75.6)	3200 (89.6)
2	0.138	2000 (56.0)	3000 (84.0)	3300 (92.4)	3700 (103.6)	4000 (112.0)	4500 (126.0)	4700 (131.6)
3	0.207	2700 (75.6)	4000 (112.0)	4200 (117.6)	4400 (123.3)	4600 (128.8)	5200 (145.6)	6000 (168.0)
5	0.345	4000 (112.0)	5100 (142.8)	5700 (159.6)	6800 (190.4)	7000 (196.0)	7500 (210.0)	8000 (224.0)
10	0.69	5700 (159.6)	8500 (238.0)	9000 (252.0)	10000 (280.0)	10000 (280.0)	10000 (280.0)	10000 (280.0)
20	1.38	8500 (238.0)	10000 (280.0)	10000 (280.0)	10000 (280.0)	10000 (280.0)	10000 (280.0)	10000 (280.0)
30	2.07	10000 (280.0)	10000 (280.0)	10000 (280.0)	10000 (280.0)	10000 (280.0)	10000 (280.0)	
40	2.76	10000 (280.0)	10000 (280.0)	10000 (280.0)	10000 (280.0)	10000 (280.0)	10000 (280.0)	
50	3.45	10000 (280.0)	10000 (280.0)	10000 (280.0)	10000 (280.0)	10000 (280.0)	10000 (280.0)	
60	4.14	10000 (280.0)	10000 (280.0)	10000 (280.0)	10000 (280.0)	10000 (280.0)		
70	4.83							
80	5.52							
90	6.21							
100	6.90							
125	8.63							

Inlet Effect ^A in. w.c. (mbar)	0.3 (0.8)	0.4 (1.0)	0.5 (1.3)	0.5 (1.3)	0.5 (1.3)	0.6 (1.5)	0.6 (1.5)
Lock Up ^B in.w.c. (mbar)	0.6 (1.5)	1.0 (2.5)	1.0 (2.5)	1.1 (2.8)	1.1 (2.8)	1.1 (2.8)	1.1 (2.8)

Notes:

*Individual regulator performance may vary from data shown.

A. Change in outlet pressure for 10 PSIG inlet pressure change.

B. Outlet pressure increase required for lock up.

 Do not operate orifice in shaded inlet pressure area.

B34 Performance Curves

7" w.c. Set Point

Type and model	B34R
Inlet size	2" NPT
Outlet size	2" NPT
Orifice size	1/4" x 3/8"
Spring	Green

All test results are reported at a base of 14.7 PSIG at 60° F and with 0.6 S.G. gas.

Performance Curves

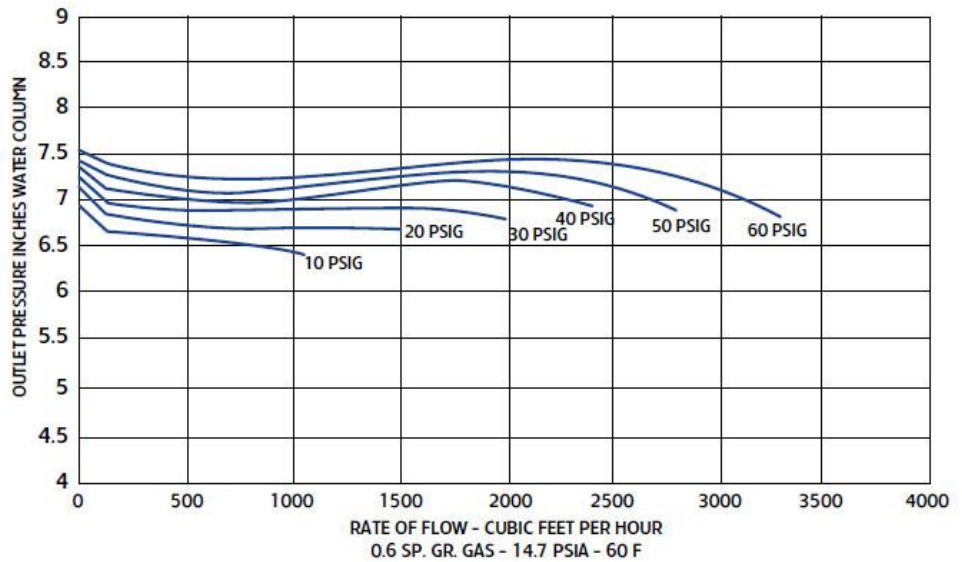

7" w.c. Set Point

Inlet size	2" NPT
Outlet size	2" NPT
Vent size	1" NPT

All test results are reported at a base of 14.7 PSIG at 60° F and with 0.6 S.G. gas.

Relief Curves

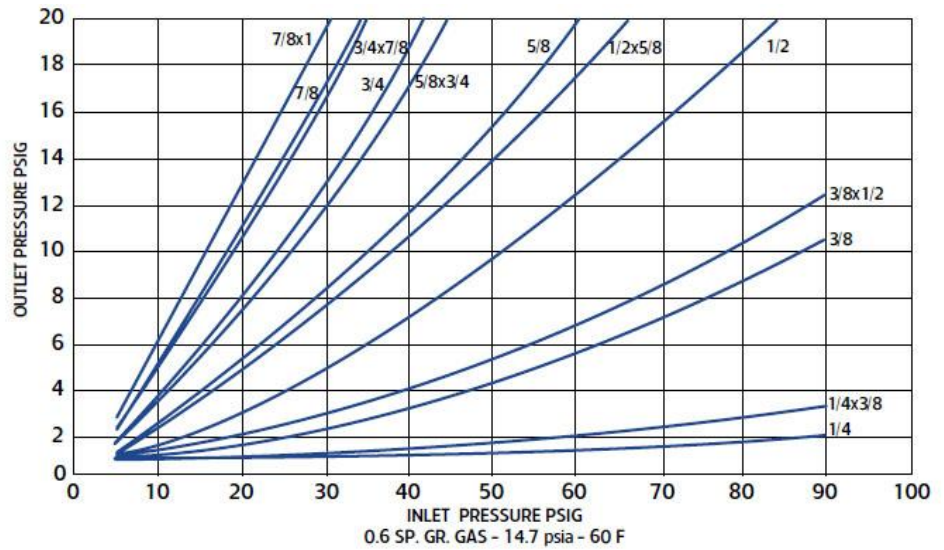

B34 Series Commercial Regulator – Models N, R, M, and D

14" w.c. (35 mbar) Capacity Table (2" w.c. Droop*)

Capacities in SCFH of 0.6 S.G. gas; base conditions of 14.7 PSIA and 60° F.

Typical Capacity Info.		Inlet Pressure		Orifice Size			
		PSIG	Bar	1/4"	1/4" x 3/8"	3/8"	3/8" x 1/2"
Manufacturer	Itron	16" w.c.	0.040			350 (9.8)	400 (11.2)
Type and model	B34R	18" w.c.	0.045		250 (7.0)	400 (11.2)	520 (14.6)
Regulator		21" w.c.	0.052	220 (6.2)	300 (8.4)	500 (14.0)	600 (16.8)
Inlet size	2" NPT	24" w.c.	0.060	260 (7.3)	370 (10.4)	550 (15.4)	750 (21.0)
Outlet size	2" NPT	1	0.069	300 (8.4)	430 (12.0)	700 (19.6)	800 (22.4)
Position	11	2	0.138	550 (15.4)	600 (16.8)	1200 (33.6)	1400 (39.2)
		3	0.207	700 (19.6)	750 (21.0)	1600 (44.8)	2200 (61.6)
		5	0.345	900 (25.2)	1000 (28.0)	2000 (56.0)	2300 (64.4)
		10	0.69	1300 (36.4)	1500 (42.0)	3000 (84.0)	3200 (89.6)
		20	1.38	2100 (58.8)	2300 (64.4)	4800 (134.4)	5000 (140.0)
		30	2.07	2700 (75.6)	2800 (78.4)	6700 (187.6)	6900 (193.2)
		40	2.76	3400 (95.2)	3600 (100.8)	7600 (212.8)	7800 (218.4)
		50	3.45	3900 (109.2)	4200 (117.6)	8700 (243.6)	9000 (252.0)
		60	4.14	4500 (126.0)	4700 (131.6)	10000 (280.0)	10000 (280.0)
		70	4.83	4900 (137.2)	5100 (142.8)	10000 (280.0)	10000 (280.0)
		80	5.52	5400 (151.2)	5600 (156.8)	10000 (280.0)	10000 (280.0)
		90	6.21	6500 (182.0)	6700 (187.6)	10000 (280.0)	10000 (280.0)
		100	6.90	7000 (196.0)	7500 (210.0)		
		125	8.63	8500 (238.0)	9000 (252.0)		



Inlet Effect ^A in. w.c. (mbar)	0.3 (0.8)	0.3 (0.8)	0.3 (0.8)	0.4 (0.8)
Lock Up ^B in.w.c. (mbar)	0.4 (0.8)	0.4 (0.8)	0.5 (0.8)	0.5 (1.3)

Notes:

*Individual regulator performance may vary from data shown.

A. Change in outlet pressure for 10 PSIG inlet pressure change.

B. Outlet pressure increase required for lock up.

-  Do not operate orifice in shaded inlet pressure area.
-  Inlet pressure is too low to deliver 14" w.c. (35 mbar).

14" w.c. (35 mbar) Capacity Table (2" Droop*) continued

Inlet Pressure		1/2"	1/2" x 5/8"	5/8"	5/8" x 3/4"	3/4"	3/4" x 7/8"	7/8"	7/8" x 1"
PSIG	Bar								
16" w.c	0.040	450 (12.6)	500 (14.0)	600 (16.8)	700 (19.6)	750 (21.0)	900 (25.2)	950 (26.6)	1050 (29.4)
18" w.c	0.045	600 (16.8)	700 (19.6)	750 (21.0)	850 (23.8)	900 (25.2)	1050 (29.4)	1200 (33.6)	1300 (36.4)
21" w.c	0.052	750 (21.0)	850 (23.8)	900 (25.2)	1100 (30.8)	1250 (35.0)	1400 (39.2)	1450 (40.6)	1500 (42.0)
24" w.c	0.060	800 (22.4)	1100 (30.8)	1150 (32.2)	1350 (37.8)	1400 (39.2)	1500 (42.0)	1550 (43.4)	1700 (47.6)
1	0.069	900 (25.2)	1200 (33.6)	1350 (37.8)	1450 (40.6)	1550 (43.4)	1650 (46.2)	1800 (50.4)	2150 (60.2)
2	0.138	1700 (47.6)	1900 (53.2)	2550 (71.4)	2800 (78.4)	3100 (86.8)	3200 (89.6)	4200 (117.6)	4400 (123.2)
3	0.207	2400 (67.2)	3000 (84.0)	3400 (95.2)	3600 (100.8)	3800 (106.4)	3900 (109.2)	4500 (126.0)	5200 (145.6)
5	0.345	2500 (70.0)	4000 (112.0)	4200 (117.6)	5000 (140.0)	5500 (154.0)	6000 (168.0)	6300 (176.4)	6500 (182.0)
10	0.69	4700 (131.6)	6000 (168.0)	7000 (196.0)	7600 (212.8)	8800 (246.4)	9000 (252.0)	9100 (254.8)	10000 (280.0)
20	1.38	8300 (232.4)	8500 (238.0)	10000 (280.0)	10000 (280.0)	10000 (280.0)	10000 (280.0)	10000 (280.0)	10000 (280.0)
30	2.07	10000 (280.0)	10000 (280.0)	10000 (280.0)	10000 (280.0)	10000 (280.0)	10000 (280.0)	10000 (280.0)	
40	2.76	10000 (280.0)	10000 (280.0)	10000 (280.0)	10000 (280.0)	10000 (280.0)	10000 (280.0)	10000 (280.0)	
50	3.45	10000 (280.0)	10000 (280.0)	10000 (280.0)	10000 (280.0)	10000 (280.0)	10000 (280.0)	10000 (280.0)	
60	4.14	10000 (280.0)	10000 (280.0)	10000 (280.0)	10000 (280.0)	10000 (280.0)	10000 (280.0)	10000 (280.0)	
70	4.83	10000 (280.0)	10000 (280.0)						
80	5.52								
90	6.21								
100	6.90								
125	8.63								

Inlet Effect ^A in. w.c. (mbar)	0.4 (0.8)	0.4 (0.8)	0.5 (1.0)	0.5 (1.3)	0.5 (1.3)	0.5 (1.3)	0.5 (1.3)	0.6 (1.5)	0.6 (1.5)
Lock Up ^B in.w.c. (mbar)	0.5 (1.3)	0.6 (1.5)	1.1 (2.5)	1.1 (2.5)	1.2 (2.8)	1.2 (2.8)	1.2 (2.8)	1.2 (2.8)	1.2 (2.8)

Notes:

*Individual regulator performance may vary from data shown.

A. Change in outlet pressure for 10 PSIG inlet pressure change.

B. Outlet pressure increase required for lock up.

████████ Do not operate orifice in shaded inlet pressure area.

B34 Performance Curves

14" w.c. Set Point

Type and model	B34R
Inlet size	2" NPT
Outlet size	2" NPT
Orifice size	1/4" x 3/8"
Spring	Purple

All test results are reported at a base of 14.7 PSIG at 60° F and with 0.6 S.G. gas.

14" w.c. Set Point

Inlet size	2" NPT
Outlet size	2" NPT
Vent size	1" NPT

All test results are reported at a base of 14.7 PSIG at 60° F and with 0.6 S.G. gas.

Performance Curves

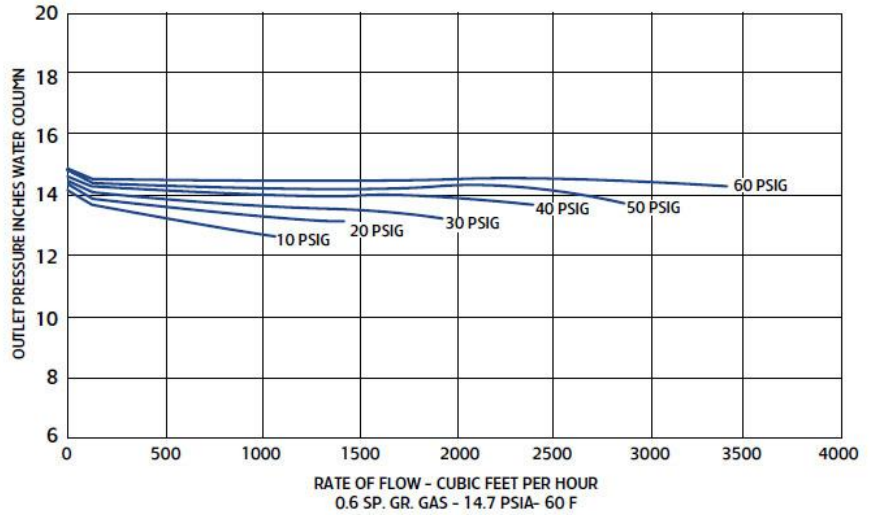

Relief Curves

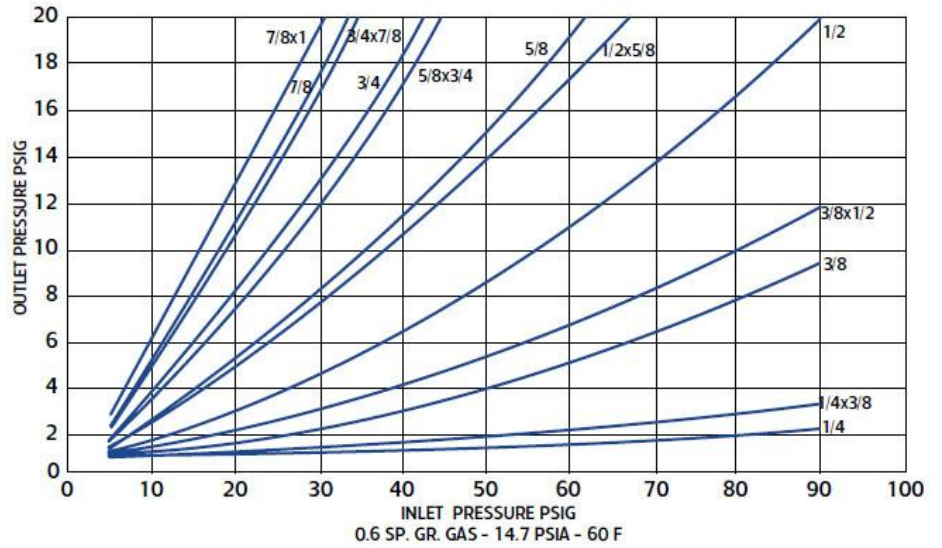

B34R Series Commercial Regulator 1 PSIG (69 mbar) Capacity Table (1% Absolute Droop*)

Capacities in SCFH of 0.6 S.G. gas; base conditions of 14.7 PSIA and 60° F.

Typical Capacity Info.	
Manufacturer	Itron
Type and model	B34R
Regulator	
Inlet size	2" NPT
Outlet size	2" NPT
Position	11

Inlet Pressure		Orifice Size					
PSIG	Bar	1/4"	1/4" x 3/8"	3/8"	3/8" x 1/2"	1/2"	1/2" x 5/8"
2	0.138						
3	0.207	550 (15.4)	575 (16.1)	1250 (35.0)	1300 (36.4)	1400 (39.2)	1500 (42.0)
5	0.345	600 (16.8)	1000 (28.0)	1500 (42.0)	1500 (42.0)	1800 (50.4)	2000 (56.0)
10	0.69	1000 (28.0)	1500 (42.0)	2000 (56.0)	2800 (78.4)	3000 (84.0)	4300 (120.4)
20	1.38	1700 (47.6)	2200 (61.6)	4000 (112.0)	4700 (131.6)	6300 (176.4)	8000 (224.0)
30	2.07	2400 (67.2)	2800 (78.4)	5600 (156.8)	6400 (179.2)	10000 (280.0)	11000 (308.0)
40	2.76	2800 (78.4)	3600 (100.8)	7000 (196.0)	7800 (218.4)	12500 (350.0)	13000 (364.0)
50	3.45	3700 (103.6)	4200 (117.6)	9000 (252.0)	9000 (252.0)	14000 (392.0)	15500 (434.0)
60	4.14	4000 (112.0)	4700 (131.6)	10000 (280.0)	10000 (280.0)	16000 (448.0)	17000 (476.0)
70	4.83	4800 (134.4)	5200 (145.6)	10800 (302.4)	11800 (330.4)	16500 (462.0)	18000 (504.0)
80	5.52	5150 (144.2)	5500 (154.0)	11400 (319.2)	13000 (364.0)	17000 (476.0)	19000 (532.0)
90	6.21	5300 (148.4)	5600 (156.8)	12300 (344.4)	14000 (392.0)	17500 (490.0)	20000 (560.0)
100	6.90	7000 (196.0)	7300 (204.4)	13500 (378.0)	15000 (420.0)	18000 (504.0)	21000 (588.0)
125	8.63	8400 (235.2)	8700 (243.6)				

Inlet Effect ^A PSIG (mbar)	0.02 (1.38)	0.02 (1.38)	0.02 (1.38)	0.02 (1.38)	0.02 (1.38)	0.02 (1.38)
Lock Up ^B PSIG (mbar)	0.02 (1.38)	0.02 (1.38)	0.02 (1.38)	0.02 (1.38)	0.02 (1.38)	0.02 (1.38)

Notes:

*Individual regulator performance may vary from data shown.

A. Change in outlet pressure for 10 PSIG inlet pressure change.

B. Outlet pressure increase required for lock up.

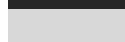
-  Do not operate orifice in shaded inlet pressure area.
-  Inlet pressure is too low to deliver 1 PSIG (69 mbar).

1 PSIG (69 mbar) Capacity Table (1% Absolute Droop*) continued

Capacities in SCFH of 0.6 S.G. gas; base conditions of 14.7 PSIA and 60° F

Inlet Pressure		Orifice Size					
PSIG	Bar	5/8"	5/8" x 3/4"	3/4"	3/4" x 7/8"	7/8"	7/8" x 1"
2	0.138	1300 (36.4)	1350 (37.8)	1400 (39.2)	1425 (39.9)	1500 (42.0)	2000 (56.0)
3	0.207	1800 (50.4)	1900 (53.2)	2000 (56.0)	2050 (57.4)	2100 (58.8)	2200 (61.6)
5	0.345	2100 (58.8)	2700 (75.6)	2700 (75.6)	3200 (89.6)	3500 (98.0)	4000 (112.0)
10	0.69	4600 (128.8)	5800 (162.4)	6000 (168.0)	7500 (210.0)	8000 (224.0)	8500 (238.0)
20	1.38	8500 (238.0)	11000 (308.0)	11300 (316.4)	12000 (336.0)	12500 (350.0)	14000 (392.0)
30	2.07	12500 (350.0)	16200 (453.6)	16500 (462.0)	17500 (490.0)	18000 (504.0)	19000 (532.0)
40	2.76	14500 (406.0)	17200 (481.6)	17600 (492.8)	18500 (518.0)	20000 (560.0)	21000 (588.0)
50	3.45	16300 (456.4)	18000 (504.0)	18400 (515.2)	19300 (540.4)	22000 (616.0)	23000 (644.0)
60	4.14	17300 (484.4)	18200 (509.6)	18700 (523.6)	20100 (562.8)	23200 (649.6)	24400 (683.2)
70	4.83						
80	5.52						
90	6.21						
100	6.90						
125	8.63						

Inlet Effect ^A PSIG (mbar)	0.03 (2.07)	0.03 (2.07)	0.03 (2.07)	0.04 (2.76)	0.04 (2.76)	0.04 (2.76)
Lock Up ^B PSIG (mbar)	0.03 (2.07)	0.03 (2.07)	0.03 (2.07)	0.04 (2.76)	0.04 (2.76)	0.05 (3.45)

Notes:

*Individual regulator performance may vary from data shown.

A. Change in outlet pressure for 10 PSIG inlet pressure change.

B. Outlet pressure increase required for lock up.

 Do not operate orifice in shaded inlet pressure area.

B34R Series Commercial Regulator

1 PSIG (69 mbar) Capacity Table (2% Absolute Droop*)

Capacities in SCFH of 0.6 S.G. gas; base conditions of 14.7 PSIA and 60° F.

Typical Capacity Info.	
Manufacturer	Itron
Type and model	B34R
Regulator	
Inlet size:	2" NPT
Outlet size:	2" NPT
Position	11

Inlet Pressure		Orifice Size					
PSIG	Bar	1/4"	1/4" x 3/8"	3/8"	3/8" x 1/2"	1/2"	1/2" x 5/8"
2	0.138						
3	0.207	700 (19.6)	750 (21.0)	1500 (42.0)	1600 (44.8)	2300 (64.4)	2400 (67.2)
5	0.345	800 (22.4)	1000 (28.0)	1900 (53.2)	2000 (56.0)	3400 (95.2)	3700 (103.6)
10	0.69	1500 (42.0)	1500 (42.0)	3000 (84.0)	3200 (89.6)	5000 (140.0)	6000 (168.0)
20	1.38	1650 (46.2)	2200 (61.6)	4500 (126.0)	4800 (134.4)	8500 (238.0)	9000 (252.0)
30	2.07	2700 (75.6)	2900 (81.2)	6300 (176.0)	6500 (182.0)	11000 (308.0)	11500 (322.0)
40	2.76	3340 (93.5)	3500 (98.0)	7400 (207.2)	7600 (212.8)	13000 (364.0)	13500 (378.0)
50	3.45	3950 (110.6)	4100 (114.8)	8500 (238.0)	9000 (252.0)	15500 (434.0)	16000 (448.0)
60	4.14	4700 (131.6)	4700 (131.6)	10500 (294.0)	10800 (302.4)	16500 (462.0)	17000 (476.0)
70	4.83	4750 (133.0)	5000 (140.0)	11000 (308.0)	11600 (324.8)	17500 (490.0)	18000 (504.0)
80	5.52	4950 (138.6)	5400 (151.2)	12000 (336.0)	13000 (364.0)	18000 (504.0)	19000 (532.0)
90	6.21	5500 (154.0)	6500 (182.0)	12500 (350.0)	13500 (378.0)	19000 (532.0)	20000 (560.0)
100	6.90	7000 (196.0)	7250 (203.0)	13250 (371.0)	14000 (392.0)	20500 (574.0)	21000 (588.0)
125	8.63	8500 (238.0)	9000 (252.0)				

Inlet Effect ^A PSIG (mbar)	0.02 (1.38)	0.02 (1.38)	0.02 (1.38)	0.02 (1.38)	0.02 (1.38)	0.02 (1.38)
Lock Up ^B PSIG (mbar)	0.02 (1.38)	0.02 (1.38)	0.02 (1.38)	0.02 (1.38)	0.02 (1.38)	0.02 (1.38)

Notes:

*Individual regulator performance may vary from data shown.

A. Change in outlet pressure for 10 PSIG inlet pressure change.

B. Outlet pressure increase required for lock up.

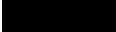
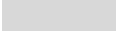
-  Do not operate orifice in shaded inlet pressure area.
-  Inlet pressure is too low to deliver 1 PSIG (69 mbar).

1 PSIG (69 mbar) Capacity Table (2% Absolute Droop*) continued

Capacities in SCFH of 0.6 S.G. gas; base conditions of 14.7 PSIA and 60° F

Inlet Pressure		Orifice Size					
PSIG	Bar	5/8"	5/8" x 3/4"	3/4"	3/4" x 7/8"	7/8"	7/8" x 1"
2	0.138	2200 (61.6)	2300 (64.4)	2400 (67.2)	2500 (70.0)	2700 (75.6)	4200 (117.6)
3	0.207	2800 (78.4)	3000 (84.0)	3400 (95.2)	3800 (106.4)	4000 (112.0)	6000 (168.0)
5	0.345	4000 (112.0)	5000 (140.0)	5200 (145.6)	6000 (168.0)	7000 (196.0)	7500 (210.0)
10	0.69	7000 (196.0)	8900 (249.2)	9000 (252.0)	10000 (280.0)	11500 (322.0)	13000 (364.0)
20	1.38	10000 (280.0)	12000 (336.0)	13000 (364.0)	15000 (420.0)	15500 (434.0)	19000 (532.0)
30	2.07	13000 (364.0)	16000 (448.0)	18000 (504.0)	19000 (532.0)	20500 (574.0)	21800 (610.4)
40	2.76	16000 (448.0)	16500 (462.0)	19000 (532.0)	19500 (546.0)	21000 (595.0)	23700 (663.6)
50	3.45	19000 (532.0)	21000 (588.0)	22000 (616.0)	22500 (630.0)	24000 (672.0)	26000 (728.0)
60	4.14	20500 (574.0)	21900 (613.2)	22800 (638.4)	23500 (658.0)	25000 (700.0)	27000 (756.0)
70	4.83						
80	5.52						
90	6.21						
100	6.90						
125	8.63						

Inlet Effect ^A PSIG (mbar)	0.03 (2.07)	0.03 (2.07)	0.03 (2.07)	0.04 (2.76)	0.04 (2.76)	0.04 (2.76)
Lock Up ^B PSIG (mbar)	0.03 (2.07)	0.03 (2.07)	0.03 (2.07)	0.04 (2.76)	0.04 (2.76)	0.05 (3.45)

Notes:

*Individual regulator performance may vary from data shown.

A. Change in outlet pressure for 10 PSIG inlet pressure change.

B. Outlet pressure increase required for lock up.

 Do not operate orifice in shaded inlet pressure area.

 Inlet pressure is too low to deliver 1 PSIG (69 mbar).

B34 Performance Curves

1 PSIG Set Point

Type and model	B34R
Inlet size	2" NPT
Outlet size	2" NPT
Orifice size	1/4" x 3/8"
Spring	Silver

All test results are reported at a base of 14.7 PSIG at 60° F and with 0.6 S.G. gas.

1 PSIG Set Point

Inlet size	2" NPT
Outlet size	2" NPT
Vent size	1" NPT

All test results are reported at a base of 14.7 PSIG at 60° F and with 0.6 S.G. gas.

Performance Curves

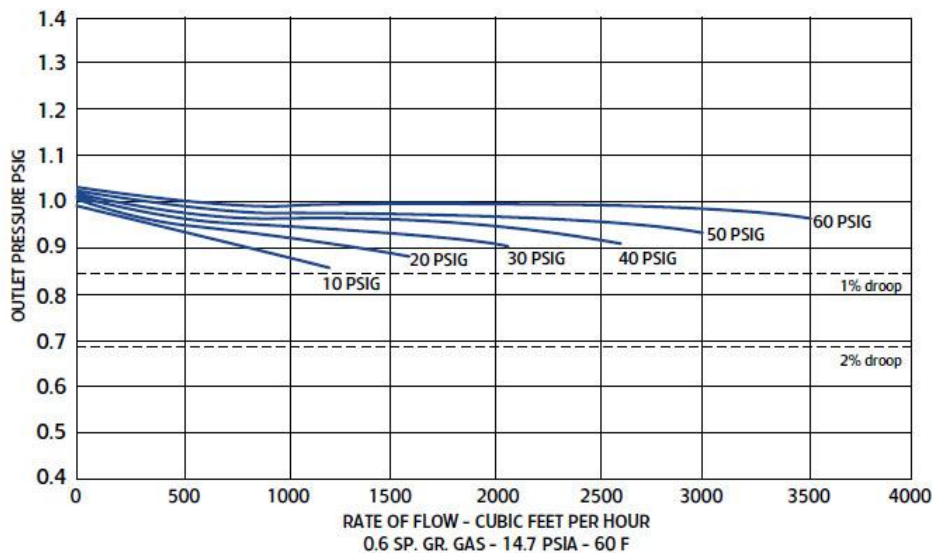

Relief Curves

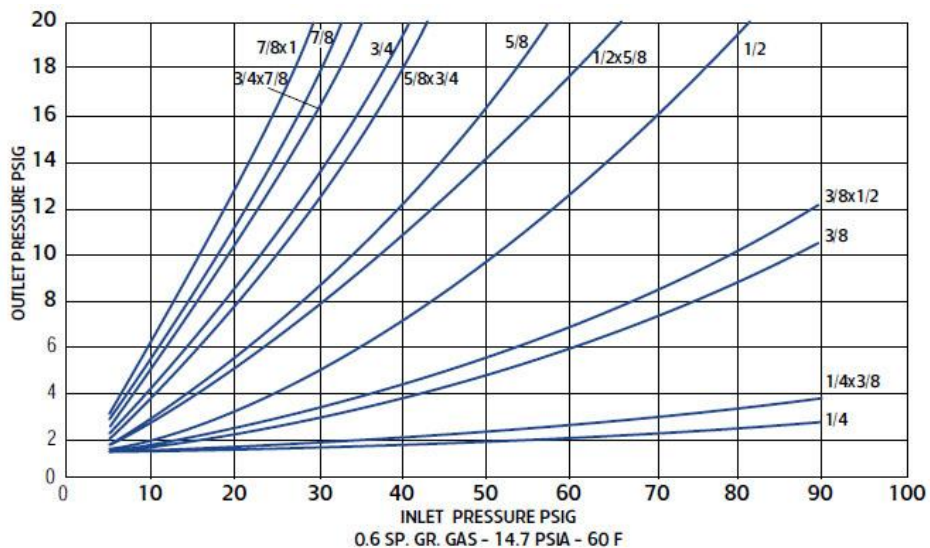

B34 Series Commercial Regulator

2 PSIG (138 mbar) Capacity Table (1% Absolute Droop*)

Capacities in SCFH of 0.6 S.G. gas; base conditions of 14.7 PSIA and 60° F.

Typical Capacity Info.		Inlet Pressure		Orifice Size					
		PSIG	Bar	1/4"	1/4" x 3/8"	3/8"	3/8" x 1/2"	1/2"	1/2" x 5/8"
Manufacturer	Itron	3	0.207						
Type and model	B34R								
Regulator		5	0.345	500 (14.0)	900 (25.2)	1000 (28.0)	1500 (42.0)	1700 (47.6)	1900 (53.2)
Inlet size	2" NPT	10	0.69	1000 (28.0)	1700 (47.6)	1800 (50.4)	2500 (70.0)	2700 (75.6)	3000 (84.0)
Outlet size	2" NPT	20	1.38	1050 (29.4)	2200 (61.6)	2300 (64.4)	4700 (131.6)	5200 (145.6)	5400 (151.2)
Spring color	Silver	30	2.07	2200 (61.6)	2800 (78.4)	3700 (103.6)	6500 (182.0)	7000 (196.0)	9500 (266.0)
Position	11	40	2.76	2700 (75.6)	3500 (98.0)	6000 (168.0)	7500 (210.0)	10800 (302.4)	12500 (350.0)
		50	3.45	3500 (98.0)	4100 (114.8)	7600 (212.8)	8800 (246.4)	13300 (372.4)	14500 (406.0)
		60	4.14	4000 (112.0)	4700 (131.6)	9500 (266.0)	10000 (280.0)	14000 (392.0)	16000 (448.0)
		70	4.83	4400 (123.2)	5000 (140.0)	10900 (305.2)	11300 (316.4)	16000 (448.0)	16500 (462.0)
		80	5.52	4800 (134.4)	5400 (151.2)	12500 (350.0)	13000 (364.0)	20000 (560.0)	21000 (588.0)
		90	6.21	5500 (154.0)	5600 (156.8)	12300 (344.4)	13500 (378.0)	21000 (588.0)	21500 (602.0)
		100	6.90	6400 (179.2)	7000 (196.0)	12800 (358.4)	14800 (414.4)	22000 (616.0)	23000 (644.0)
		125	8.63	7000 (196.0)	7400 (207.2)				



Inlet Effect ^A PSIG (mbar)	0.02 (1.38)	0.02 (1.38)	0.02 (1.38)	0.02 (1.38)	0.03 (2.07)	0.03 (2.07)
Lock Up ^B PSIG (mbar)	0.03 (2.07)	0.03 (2.07)	0.03 (2.07)	0.03 (2.07)	0.03 (2.07)	0.03 (2.07)

Notes:

*Individual regulator performance may vary from data shown.

A. Change in outlet pressure for 10 PSIG inlet pressure change.

B. Outlet pressure increase required for lock up.

-  Do not operate orifice in shaded inlet pressure area.
-  Inlet pressure is too low to deliver 2 PSIG (138 mbar).

2 PSIG (138 mbar) Capacity Table (1% Absolute Droop*) continued

Capacities in SCFH of 0.6 S.G. gas; base conditions of 14.7 PSIA and 60° F.

Inlet Pressure		Orifice Size					
PSIG	Bar	5/8"	5/8" x 3/4"	3/4"	3/4" x 7/8"	7/8"	7/8" x 1"
3	0.207		1300 (36.4)	1500 (42.0)	1600 (44.8)	1700 (47.6)	2000 (56.0)
5	0.345	2000 (56.0)	2250 (63.0)	2500 (70.0)	3000 (84.0)	3000 (84.0)	3200 (89.6)
10	0.69	3200 (89.6)	4800 (134.4)	5000 (140.0)	6500 (182.0)	6800 (190.4)	7500 (210.0)
20	1.38	5500 (154.0)	8500 (238.0)	9000 (252.0)	9000 (252.0)	10600 (296.8)	11200 (313.6)
30	2.07	10000 (280.0)	13000 (364.0)	14500 (406.0)	16000 (448.0)	17000 (476.0)	17400 (487.2)
40	2.76	13000 (364.0)	16500 (462.0)	17900 (501.2)	18300 (512.4)	18900 (529.2)	20600 (576.8)
50	3.45	15000 (420.0)	19000 (532.0)	20000 (560.0)	20500 (574.0)	21000 (588.0)	22400 (627.2)
60	4.14	17000 (476.0)	19500 (546.0)	20500 (574.0)	21000 (588.0)	21500 (602.0)	23100 (646.8)
70	4.83						
80	5.52						
90	6.21						
100	6.90						
125	8.63						

Inlet Effect ^A PSIG (mbar)	0.03 (2.07)	0.03 (2.07)	0.03 (2.07)	0.03 (2.07)	0.03 (2.07)	0.03 (2.07)
Lock Up ^B PSIG (mbar)	0.04 (2.76)	0.04 (2.76)	0.04 (2.76)	0.06 (4.14)	0.07 (4.83)	0.07 (4.83)

Notes:

*Individual regulator performance may vary from data shown.

A. Change in outlet pressure for 10 PSIG inlet pressure change.

B. Outlet pressure increase required for lock up.

 Do not operate orifice in shaded inlet pressure area.

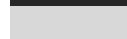
 Inlet pressure is too low to deliver 2 PSIG (138 mbar).

B34R Series Commercial Regulator

2 PSIG (138 mbar) Capacity Table (2% Absolute Droop*)

Capacities in SCFH of 0.6 S.G. gas; base conditions of 14.7 PSIA and 60° F.

Inlet Pressure		Orifice Size							
		PSIG	Bar	1/4"	1/4" x 3/8"	3/8"	3/8" x 1/2"	1/2"	1/2" x 5/8"
Typical Capacity Info.									
Manufacturer	Itron								
Type and model	B34R								
Regulator									
Inlet size:	2" NPT								
Outlet size:	2" NPT								
Spring color:	Silver								
Position	11								
		3	0.207						
		5	0.345	700 (19.6)	900 (25.2)	1800 (50.4)	2000 (56.0)	2800 (78.4)	3100 (86.8)
		10	0.69	1300 (36.4)	1500 (42.0)	2800 (78.4)	3000 (84.0)	4500 (126.0)	5800 (162.4)
		20	1.38	1650 (46.2)	2200 (61.6)	4500 (126.0)	4800 (134.4)	8500 (238.0)	9000 (252.0)
		30	2.07	2700 (75.6)	2900 (81.2)	6300 (176.4)	6500 (182.0)	11000 (308.0)	11500(322.0)
		40	2.76	3340 (93.5)	3500 (98.0)	7450 (208.6)	7600 (212.8)	13200 (369.6)	13500(378.0)
		50	3.45	3950 (110.6)	4100 (114.8)	8700 (243.6)	9000 (252.0)	15500 (434.0)	16000(448.0)
		60	4.14	4500 (126.0)	4700 (131.6)	10200(285.6)	10500 (294.0)	17000 (476.0)	17000(476.0)
		70	4.83	4740 (132.7)	5000 (140.0)	10900(305.2)	11600 (324.8)	19000 (532.0)	20500(574.0)
		80	5.52	4950 (138.6)	5400 (151.2)	12500(350.0)	13000 (364.0)	21000 (588.0)	22500(630.0)
		90	6.21	5800 (162.4)	6000 (168.0)	13000(364.0)	14000 (392.0)	22300 (624.4)	23400(655.2)
		100	6.90	6900 (193.2)	7500 (210.0)	13500(378.0)	15500 (434.0)	23500 (658.0)	24900(697.2)
		125	8.63	8300 (232.4)	8800 (246.4)				



Inlet Effect ^A PSIG (mbar)	0.02 (1.38)	0.02 (1.38)	0.02 (1.38)	0.02 (1.38)	0.03 (2.07)	0.03 (2.07)
Lock Up ^B PSIG (mbar)	0.03 (2.07)	0.03 (2.07)	0.03 (2.07)	0.03 (2.07)	0.03 (2.07)	0.03 (2.07)

Notes:

*Individual regulator performance may vary from data shown.

A. Change in outlet pressure for 10 PSIG inlet pressure change.

B. Outlet pressure increase required for lock up.

-  Do not operate orifice in shaded inlet pressure area.
-  Inlet pressure is too low to deliver 2 PSIG (138 mbar).

2 PSIG (138 mbar) Capacity Table (2% Absolute Droop*) continued

Capacities in SCFH of 0.6 S.G. gas; base conditions of 14.7 PSIA and 60° F.

Inlet Pressure		Orifice Size					
PSIG	Bar	5/8"	5/8" x 3/4"	3/4"	3/4" x 7/8"	7/8"	7/8" x 1"
3	0.207		2500 (70.0)	2800 (78.4)	3500 (98.0)	3700 (103.6)	4000 (112.0)
5	0.345	3200 (89.6)	3600 (100.8)	4100 (114.8)	5000 (140.0)	5000 (140.0)	6000 (168.0)
10	0.69	6000 (168.0)	7000 (196.0)	7500 (210.0)	9500 (266.0)	9800 (274.4)	12000 (336.0)
20	1.38	10000 (280.0)	12000 (336.0)	13000 (364.0)	14000 (392.0)	15500 (434.0)	19000 (532.0)
30	2.07	13000 (364.0)	16000 (448.0)	18500 (518.0)	19500 (546.0)	20500 (574.0)	21800 (610.4)
40	2.76	16000 (448.0)	19000 (532.0)	20000 (560.0)	21000 (588.0)	22000 (616.0)	23700 (663.6)
50	3.45	20500 (574.0)	21000 (588.0)	24000 (672.0)	25000 (700.0)	26500 (742.0)	27500 (770.0)
60	4.14	21300 (596.4)	22800 (638.4)	25700 (719.6)	26400 (739.2)	28000 (784.0)	28300 (792.4)
70	4.83						
80	5.52						
90	6.21						
100	6.90						
125	8.63						



Inlet Effect ^A PSIG (mbar)	0.03 (2.07)	0.03 (2.07)	0.03 (2.07)	0.03 (2.07)	0.03 (2.07)	0.03 (2.07)
Lock Up ^B PSIG (mbar)	0.04 (2.76)	0.04 (2.76)	0.04 (2.76)	0.06 (4.14)	0.07 (4.83)	0.07 (4.83)

Notes:

*Individual regulator performance may vary from data shown.

A. Change in outlet pressure for 10 PSIG inlet pressure change.

B. Outlet pressure increase required for lock up.

-  Do not operate orifice in shaded inlet pressure area.
-  Inlet pressure is too low to deliver 2 PSIG (138 mbar).

B34 Performance Curves

2 PSIG Set Point

Type and model	B34R
Inlet size	2" NPT
Outlet size	2" NPT
Orifice size	1/4" x 3/8"
Spring	Silver

All test results are reported at a base of 14.7 PSIG at 60° F and with 0.6 S.G. gas.

2 PSIG Set Point

Inlet size	2" NPT
Outlet size	2" NPT
Vent size	1" NPT

All test results are reported at a base of 14.7 PSIG at 60° F and with 0.6 S.G. gas.

Performance Curves

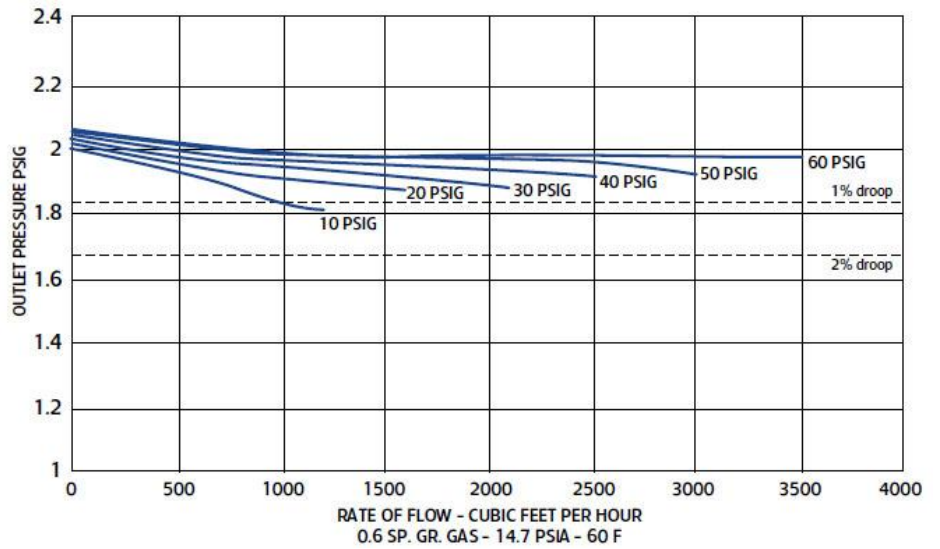

Relief Curves

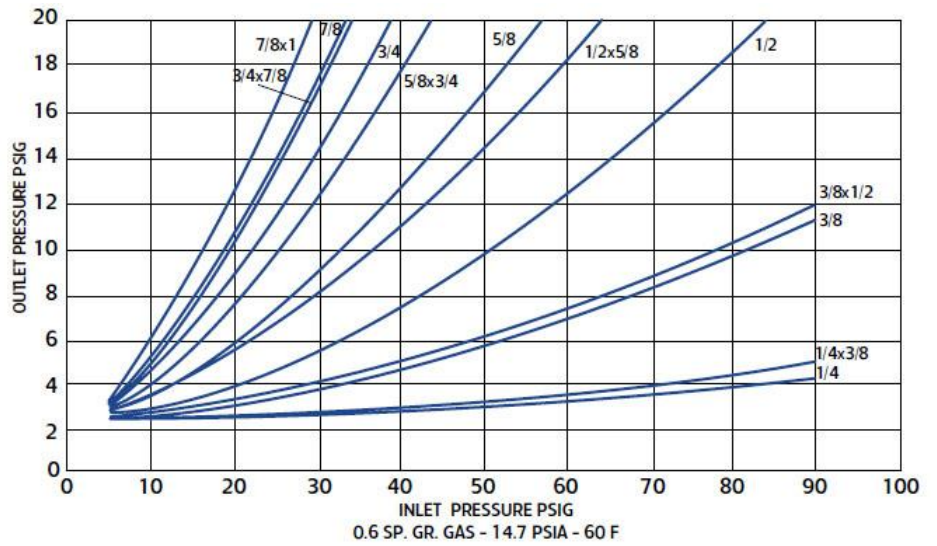

B34R Series Commercial Regulator

5 PSIG (345 mbar) Capacity Table (1% Absolute Droop*)

Capacities in SCFH of 0.6 S.G. gas; base conditions of 14.7 PSIA and 60° F.

Typical Capacity Info.		Inlet Pressure		Orifice Size					
		PSIG	Bar	1/4"	1/4" x 3/8"	3/8"	3/8" x 1/2"	1/2"	1/2" x 5/8"
Manufacturer	Itron	10	0.69	500 (14.0)	700 (19.6)	800 (22.4)	900 (25.2)	900 (25.2)	1000 (28.0)
Type and model	B34R	20	1.38	800 (22.4)	1100 (30.8)	1100 (30.8)	1300 (36.4)	1500 (42.0)	1900 (53.2)
Regulator		30	2.07	1100 (30.8)	1300 (36.4)	1400 (39.2)	1500 (42.0)	1700 (47.6)	2000 (56.0)
Inlet size	2" NPT	40	2.76	1200 (33.6)	1400 (39.2)	1500 (42.0)	1700 (47.6)	2000 (56.0)	2700 (75.6)
Outlet size	2" NPT	50	3.45	1300 (36.4)	1500 (42.0)	1700 (47.6)	2000 (56.0)	2500 (70.0)	3500 (98.0)
Spring color	Red Nested	60	4.14	1400 (39.2)	1700 (47.6)	1800 (50.4)	3200 (89.6)	3500 (98.0)	4400 (123.2)
Position	11	70	4.83	1500 (42.0)	1800 (50.4)	1900 (53.2)	3350 (94.9)	3600 (100.8)	4800 (134.4)
		80	5.52	1600 (44.8)	1900 (53.2)	2000 (56.0)	4200 (117.6)	4500 (126.0)	5100 (142.8)
		90	6.21	2000 (56.0)	2800 (78.4)	3000 (84.0)	4400 (123.2)	4800 (134.4)	6500 (182.0)
		100	6.90	2600 (72.8)	3200 (89.6)	3700 (103.6)	4550 (127.4)	5100 (142.8)	7300 (204.4)
		125	8.63	3200 (89.6)	3400 (95.2)				



Inlet Effect ^A PSIG (mbar)	0.02 (1.38)	0.02 (1.38)	0.02 (1.38)	0.02 (1.38)	0.03 (2.07)	0.03 (2.07)
Lock Up ^B PSIG (mbar)	0.05 (0.8)	0.05 (0.8)	0.07 (4.83)	0.07 (4.83)	0.07 (4.83)	0.07 (4.83)

Notes:

*Individual regulator performance may vary from data shown.

A. Change in outlet pressure for 10 PSIG inlet pressure change.

B. Outlet pressure increase required for lock up.

-  Do not operate orifice in shaded inlet pressure area.
-  Inlet pressure is too low to deliver 5 PSIG (345 mbar).

5 PSIG (345 mbar) Capacity Table (1% Absolute Droop*) continued

Capacities in SCFH of 0.6 S.G. gas; base conditions of 14.7 PSIA and 60° F.

Inlet Pressure		Orifice Size					
PSIG	Bar	5/8"	5/8" x 3/4"	3/4"	3/4" x 7/8"	7/8"	7/8" x 1"
10	0.69	1100 (30.8)	1200 (33.6)	1300 (36.4)	1350 (37.8)	1400 (39.2)	1500 (42.0)
20	1.38	1950 (54.6)	2000 (56.0)	2200 (61.6)	2300 (64.4)	2500 (70.0)	2700 (75.6)
30	2.07	2300 (64.4)	2600 (72.8)	2700 (75.6)	3000 (84.0)	3500 (98.0)	3800 (106.4)
40	2.76	2800 (78.4)	3200 (89.6)	3300 (92.4)	3700 (103.6)	4500 (126.0)	4750 (133.0)
50	3.45	3600 (100.8)	3800 (106.4)	4200 (117.6)	4300 (120.4)	5500 (154.0)	6250 (175.0)
60	4.14	4700 (131.6)	6000 (168.0)	8000 (224.0)	8500 (238.0)	10000 (280.0)	11500 (322.0)
70	4.83						
80	5.52						
90	6.21						
100	6.90						
125	8.63						

Inlet Effect ^A PSIG (mbar)	0.03 (2.07)	0.03 (2.07)	0.03 (2.07)	0.03 (2.07)	0.03 (2.07)	0.03 (2.07)
Lock Up ^B PSIG (mbar)	0.07 (4.83)	0.07 (4.83)	0.07 (4.83)	0.07 (4.83)	0.07 (4.83)	0.08 (5.52)

Notes:

*Individual regulator performance may vary from data shown.

A. Change in outlet pressure for 10 PSIG inlet pressure change.

B. Outlet pressure increase required for lock up.

 Do not operate orifice in shaded inlet pressure area.

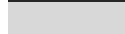
 Inlet pressure is too low to deliver 5 PSIG (345 mbar).

B34R Series Commercial Regulator

5 PSIG (345 mbar) Capacity Table (2% Absolute Droop*)

Capacities in SCFH of 0.6 S.G. gas; base conditions of 14.7 PSIA and 60° F.

Typical Capacity Info.		Inlet Pressure		Orifice Size							
		PSIG	Bar	1/4"	1/4" x 3/8"	3/8"	3/8" x 1/2"	1/2"	1/2" x 5/8"		
Manufacturer	Itron										
Type and model	B34R	10	0.69	800 (22.4)	950 (26.6)	1000 (28.0)	1200 (33.6)	1300 (36.4)	1550 (43.4)		
Regulator		20	1.38	1100 (30.8)	1600 (44.8)	1700 (47.6)	2300 (64.4)	2750 (77.0)	2850 (79.8)		
Inlet size	2" NPT	30	2.07	1500 (42.0)	2100 (58.8)	2200 (61.6)	2800 (78.4)	3300 (92.4)	3500 (98.0)		
Outlet size	2" NPT	40	2.76	2000 (56.0)	2400 (67.2)	2700 (75.6)	3900 (109.2)	4300 (120.4)	5000 (140.0)		
Spring color	Red nested	50	3.45	2500 (70.0)	3250 (91.0)	3400 (95.2)	4800 (134.4)	5700 (159.6)	7000 (196.0)		
Position	11	60	4.14	2800 (78.4)	4000 (112.0)	4500 (126.0)	5500 (154.0)	6500 (182.0)	7500 (210.0)		
		70	4.83	2900 (81.2)	4200 (117.6)	4600 (128.8)	5700 (159.6)	7300 (204.4)	8600 (240.8)		
		80	5.52	3100 (86.8)	4500 (126.0)	4800 (134.4)	8200 (229.6)	8600 (240.8)	9500 (266.0)		
		90	6.21	3600 (100.8)	5300 (148.4)	5700 (159.6)	9000 (252.0)	10000 (280.0)	15000 (420.0)		
		100	6.90	4100 (114.8)	6000 (168.0)	6500 (182.0)	10200 (285.6)	11000 (308.0)	15900 (445.2)		
		125	8.63	4900 (137.2)	6800 (190.4)						

Inlet Effect ^A PSIG (mbar)	0.02 (1.38)	0.02 (1.38)	0.02 (1.38)	0.02 (1.38)	0.03 (2.07)	0.03 (2.07)
Lock Up ^B PSIG (mbar)	0.05 (3.45)	0.05 (3.45)	0.07 (4.83)	0.07 (4.83)	0.07 (4.83)	0.07 (4.83)

Notes:

*Individual regulator performance may vary from data shown.

A. Change in outlet pressure for 10 PSIG inlet pressure change.

B. Outlet pressure increase required for lock up.

 Do not operate orifice in shaded inlet pressure area.

 Inlet pressure is too low to deliver 5 PSIG (345 mbar).

5 PSIG (345 mbar) Capacity Table (2% Absolute Droop*) continued

Capacities in SCFH of 0.6 S.G. gas; base conditions of 14.7 PSIA and 60° F.

Inlet Pressure		Orifice Size					
PSIG	Bar	5/8"	5/8" x 3/4"	3/4"	3/4" x 7/8"	7/8"	7/8" x 1"
10	0.69	1600 (44.8)	2000 (56.0)	2200 (61.6)	2300 (64.4)	2450 (68.6)	2500 (70.0)
20	1.38	3000 (84.0)	3500 (98.0)	3800 (106.4)	4000 (112.0)	4300 (120.4)	4500 (126.0)
30	2.07	4100 (114.8)	4400 (123.2)	4500 (126.0)	5700 (159.6)	6800 (190.4)	7200 (201.6)
40	2.76	5300 (148.4)	6400 (179.2)	7000 (196.0)	7500 (210.0)	8000 (224.0)	10500 (294.0)
50	3.45	7200 (201.6)	7500 (210.0)	8300 (232.4)	9500 (266.0)	10600 (296.8)	11500 (322.0)
60	4.14	8800 (246.4)	13300 (372.4)	15000 (420.0)	15800 (442.4)	16500 (462.0)	17000 (476.0)
70	4.83						
80	5.52						
90	6.21						
100	6.90						
125	8.63						

Inlet Effect ^A PSIG (mbar)	0.03 (2.07)	0.03 (2.07)	0.03 (2.07)	0.03 (2.07)	0.03 (2.07)	0.03 (2.07)
Lock Up ^B PSIG (mbar)	0.07 (4.83)	0.07 (4.83)	0.07 (4.83)	0.07 (4.83)	0.08 (5.52)	0.09 (6.21)

Notes:

*Individual regulator performance may vary from data shown.

A. Change in outlet pressure for 10 PSIG inlet pressure change.

B. Outlet pressure increase required for lock up.

 Do not operate orifice in shaded inlet pressure area.

 Inlet pressure is too low to deliver 5 PSIG (345 mbar).

B34 Performance Curves

5 PSIG Set Point

Type and model	B34R
Inlet size	2" NPT
Outlet size	2" NPT
Orifice size	1/4" x 3/8"
Spring	Red-Nested

All test results are reported at a base of 14.7 PSIG at 60° F and with 0.6 S.G. gas.

Performance Curves

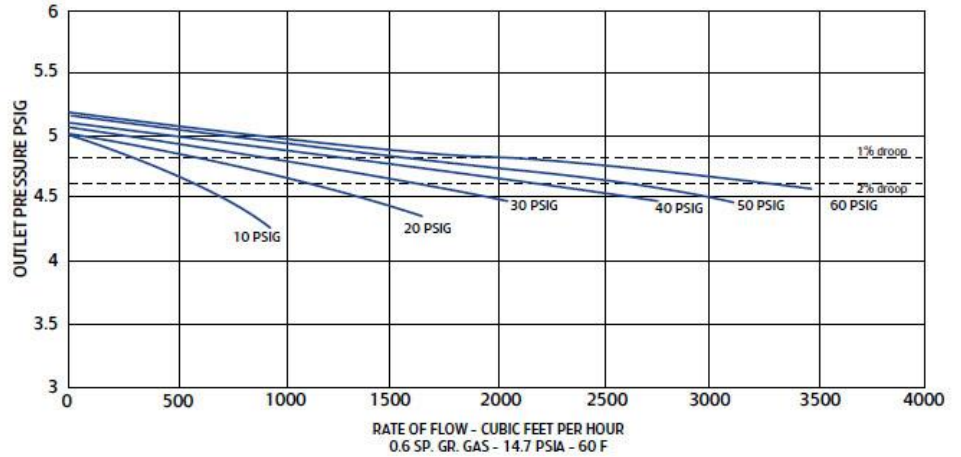

5 PSIG Set Point

Inlet size	2" NPT
Outlet size	2" NPT
Vent size	1" NPT

All test results are reported at a base of 14.7 PSIG at 60° F and with 0.6 S.G. gas.

Relief Curves

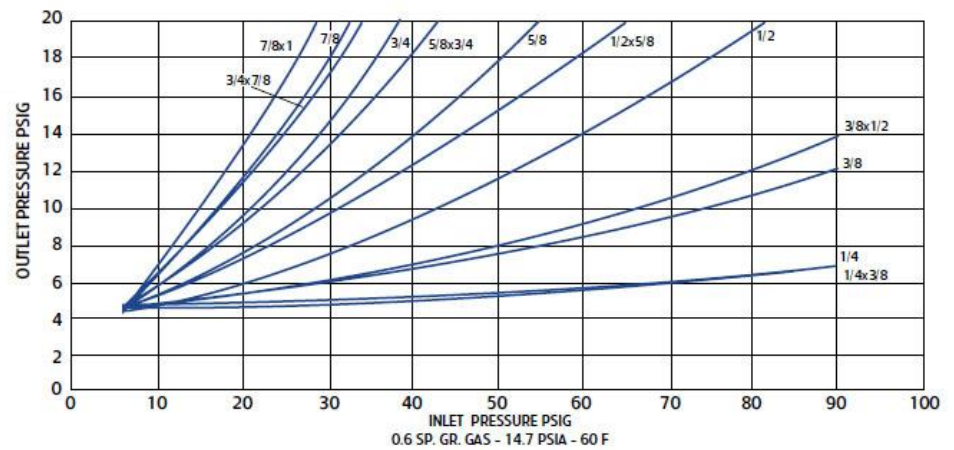

B34IM Series Commercial Regulator

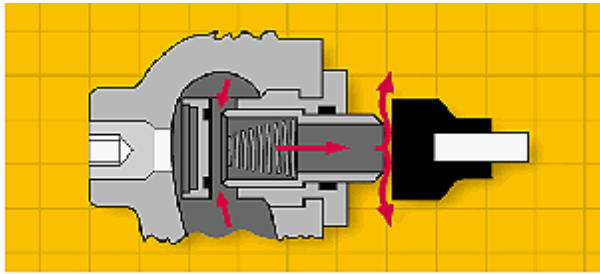

A. Standard regulator and upstream monitor orifice.

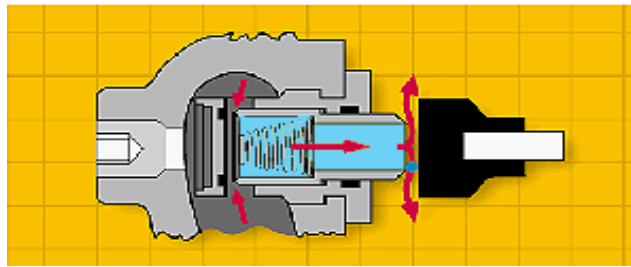

B. Standard regulator orifice failed; upstream monitor orifice control.

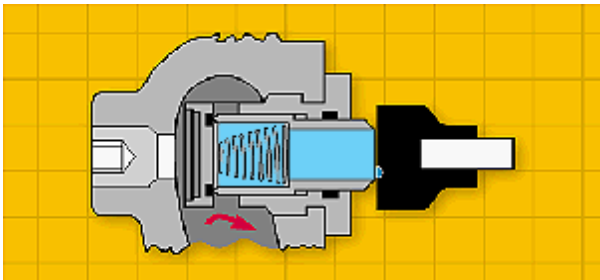

C. Main orifice failed - upstream monitor orifice *lock-up*.

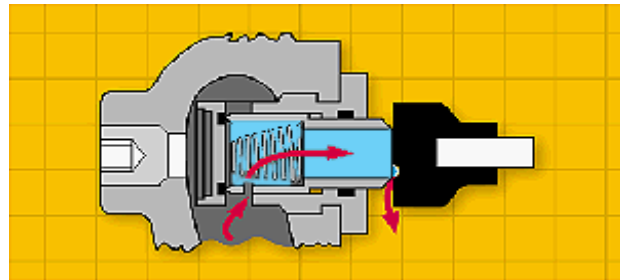

D. V option - vents a small volume of gas to atmosphere through relief valve.



Principle of Operation

A. Normal operation. The internal monitor IM orifice performs like a standard regulator and monitor regulator in that main orifice and valve seat actuate to control outlet flow and pressure under normal flow conditions. If there is no demand, the main seat *and internal monitor orifice will close*.

B. Monitor operation. If the main valve seat fails to control the gas flow and pressure due to foreign matter between the seat and orifice face, or if the seat is eroded, the internal monitor orifice automatically goes into operating position at a slightly higher outlet pressure (see Internal Monitor Lock-up Pressure table). Any time the pressure on the main diaphragm exceeds the force of the fixed monitor spring, the increased outlet pressure causes the main valve seat to push against the sliding orifice. The sliding orifice compresses the monitor spring and positions the monitor orifice to control the gas flow. The IM orifice now functions as a monitor regulator and continues to monitor as long as the main seat fails to control at the normal adjusted outlet pressure. If the gas load demand is increased beyond the internal monitor's capacity, the outlet pressure is reduced to normal adjusted pressure and the regulator resumes normal regulation.

C. Monitor lock-up. If the demand for gas is decreased to zero flow during monitor operation, the sliding orifice continues to close until its orifice is in the gas tight position (monitor lock-up) against the BUNA-N monitor valve seat. (See the Internal Monitor Lock-up Pressure table for the outlet pressure required for internal monitor lock-up.)

D. Vent hole V option. On installations where a small volume of over-pressure gas can be safely vented to the atmosphere, the advantages of both the relief valve and monitor safety can be combined. If the flow is decreased to zero or just greater than zero, the vent hole in the internal monitor orifice allows gas to slowly bleed downstream and cause the pressure to rise to the relief point of the internal relief valve. The gas then bleeds to the atmosphere indicating a problem with the regulator.

B34IM Series Commercial Regulator

Capacities in SCFH of 0.6 S.G. gas; base conditions of 14.7 PSIA and 60° F.

Outlet Pressure		5.5" w.c.	7" w.c.	11" w.c.	14" w.c.	20" w.c.	1 PSIG	2 PSIG	3 PSIG	5 PSIG	Corresponding Inlet-Outlet Pressure Changes		
Pressure Droop		1" w.c.	1" w.c.	2" w.c.	2" w.c.	3" w.c.	.2 PSIG	.2 PSIG	.3 PSIG	.5 PSIG			
Spring		Brown	Green	Black	Purple	Blue	Silver	Silver	Yellow	Red			
	Inlet Pressure PSIG*	Increase in Pressure Req'd. for No Flow**	Capacity (SCFH)									Inlet Pressure Change PSIG	Corresponding Outlet Pressure Change in w.c.**
3/4" Orifice	.5	0.4" w.c.	1000	900	-	-	-	-	-	-	-	-	-
	1.0	0.4" w.c.	1500	1400	1300	1100	1000	-	-	-	-	1.0	0.05
	2.0	0.4" w.c.	2300	2200	2100	1850	1700	1750	-	-	-	2.0	0.1
	3.0	0.4" w.c.	2900	3000	2900	2450	2400	2500	1650	-	-	3.0	0.2
	5.0	0.4" w.c.	4500	4500	4100	3500	3400	3700	2850	1600	-	5.0	0.3
	10.0	0.4" w.c.	7500	7500	7000	5300	5700	6400	6200	3300	3300	10.0	0.5
	15.0	0.4" w.c.	10000	10000	9200	7000	7900	8500	8900	5200	5000	15.0	0.8
	25.0	0.4" w.c.	10000	10000	10000	10000	10000	13000	14000	8800	9000	25.0	1.0
60.0	0.4" w.c.	10000	10000	10000	10000	10000	20000	20000	20000	19000	60.0	2.5	
5/8" Orifice	.5	0.4" w.c.	800	775	700	-	-	-	-	-	-	-	-
	1.0	0.4" w.c.	1300	1100	1200	900	850	-	-	-	-	1.0	0.05
	2.0	0.4" w.c.	2100	1900	1900	1500	1450	1900	-	-	-	2.0	0.1
	3.0	0.4" w.c.	2800	2400	2700	2000	2000	2500	1400	-	-	3.0	0.1
	5.0	0.4" w.c.	4000	3200	3500	3000	2800	3200	2350	1700	-	5.0	0.3
	10.0	0.4" w.c.	6500	6500	6300	5000	4400	5300	4450	3000	3000	10.0	0.5
	15.0	0.4" w.c.	8500	8500	8500	7000	7800	7700	6600	4600	4600	15.0	0.6
	25.0	0.4" w.c.	10000	10000	10000	10000	10000	11000	10700	7200	7200	25.0	0.8
60.0	0.4" w.c.	10000	10000	10000	10000	10000	20000	20000	19000	18500	60.0	2.0	
1/2" Orifice	1.0	0.3" w.c.	1000	950	850	850	650	-	-	-	-	-	-
	2.0	0.3" w.c.	1550	1350	1400	1350	1150	1150	-	-	-	-	-
	3.0	0.3" w.c.	1900	1750	1900	1750	1650	1600	900	-	-	2.0	0.1
	5.0	0.3" w.c.	2900	2500	2600	2500	2200	2250	1700	1550	-	3.0	0.2
	10.0	0.3" w.c.	4550	3650	4000	3900	3400	3900	3000	2300	2300	5.0	0.25
	15.0	0.3" w.c.	6100	6300	6150	5500	4400	5800	4300	3300	2450	10.0	0.3
	25.0	0.3" w.c.	9000	9000	8600	8000	8500	8300	7150	5200	5350	15.0	0.5
	60.0	0.4" w.c.	10000	10000	10000	10000	10000	17000	16300	14500	13000	25.0	0.7
	75.0	0.4" w.c.	10000	10000	10000	10000	10000	20000	19800	17500	17500	60.0	1.3
100.0	0.5" w.c.	-	-	-	-	-	20000	20000	20000	20000	75.0	1.8	
3/8" Orifice	1.0	0.3" w.c.	650	650	550	500	450	-	-	-	-	-	-
	2.0	0.3" w.c.	1000	1000	1000	900	750	850	-	-	-	2.0	0.1
	3.0	0.3" w.c.	1250	1200	1200	1200	1000	1000	650	-	-	3.0	0.1
	5.0	0.3" w.c.	1700	1800	1650	1800	1600	1600	1000	800	-	5.0	0.2
	10.0	0.3" w.c.	2800	2800	2600	2600	2500	2500	1900	1600	1700	10.0	0.3
	15.0	0.3" w.c.	4000	4000	3800	3800	3350	3400	2800	2300	2500	15.0	0.3
	25.0	0.3" w.c.	5350	5500	5500	5200	5200	5000	4250	3400	3700	25.0	0.5
	60.0	0.3" w.c.	10000	10000	10000	10000	9000	10000	8950	8600	8200	60.0	1.0
	75.0	0.3" w.c.	10000	10000	10000	10000	10000	12000	11700	11000	11000	75.0	1.2
	100.0	0.3" w.c.	10000	10000	10000	10000	10000	15000	15000	15000	15000	100.0	1.6
125.0	0.3" w.c.	10000	10000	10000	10000	10000	18000	18000	18000	18000	-	-	

Notes:

Individual regulator performance may vary from data shown.

Max. capacity for 1-1/2" outlet pipe approx. 7500 cu. ft. per hr.; 2" outlet pipe 10,000 cu. ft. per hr. for outlet pressure less than 1 PSIG.

Set point on each of the above outlet pressures was at a flow rate of 200 cu. ft. per hr.

* The column showing inlet pressures and recommended orifice size is for PSIG Inlet to inches water column only.

For PSIG outlet pressure, any orifice size can be used for inlet pressures up to 150 PSIG.

** Only for inches w.c. outlet conditions.

B34 IM Performance Curves

7" w.c. Set Point

Inlet Size	1-1/2" NPT
Outlet Size	2" NPT
Inlet Pressure	20 PSIG at set
Orifice Size	3/4"
Spring Range	5.1 to 7.0" w.c.
Bolt Circle Diameter	12-1/16"
Flow Rate at Set	200 scfh

- A. 60 PSIG inlet pressure W.O.R. 19M at 4.89 PSIG
- B. 40 PSIG inlet pressure SET
- C. 25 PSIG inlet pressure W.O.R.

7" w.c. Set Point

Inlet Size	2" NPT
Outlet Size	2" NPT
Inlet Pressure	20 PSIG at set
Orifice Size	3/4"
Spring Range	5.1 to 7.0" w.c.
Bolt Circle Diameter	12-1/16"
Flow Rate at Set	200 SCFH

- A. 60 PSIG inlet pressure W.O.R. 19M at 4.89 PSIG
- B. 40 PSIG inlet pressure SET
- C. 25 PSIG inlet pressure W.O.R.

Normal Curves

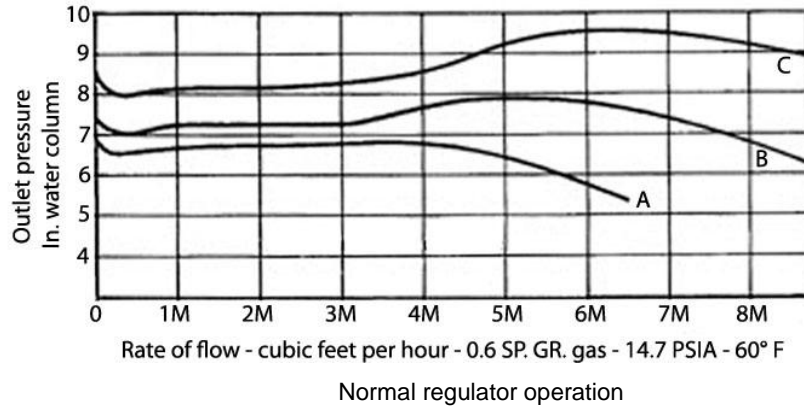

Relief Monitor Curves

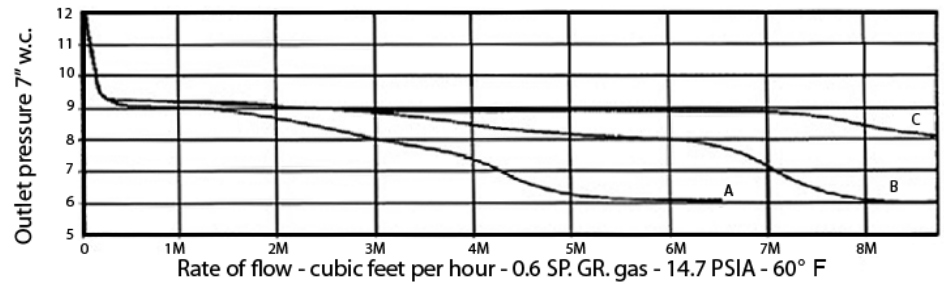

B34 Performance Curves

2 PSIG Set Point

Inlet size	2" NPT
Outlet size	2" NPT
Inlet pressure	40 PSIG at set
Orifice size	3/4"
Spring Range	0.8 to 2.2 PSIG
Bolt circle diameter	12-1/16"
Flow rate at set	200 SCFH
Position	9
Loading ring	Set at 12°

- A. 60 PSIG inlet pressure W.O.R. 19M at 4.89 PSIG
- B. 40 PSIG inlet pressure SET
- C. 25 PSIG inlet pressure W.O.R.
- D. 40 PSIG inlet pressure - failed condition
- E. 60 PSIG inlet pressure - failed condition

Relief Monitor Curves

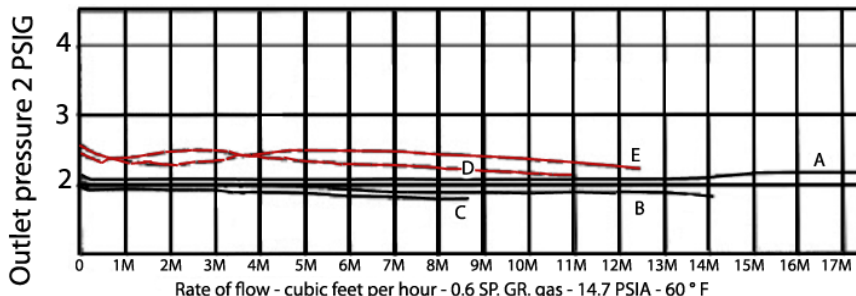

- A, B, C. Normal regulator operation.
- D, E. Main seat failed open with 1/8" x 1/2" diameter nylon disc. Internal monitor orifice in operation.

5 PSIG Set Point

Inlet Size	2" NPT
Outlet Size	2" NPT
Inlet Pressure	40 PSIG at set
Orifice Size	3/4"
Spring Range	1.8 to 5.75 PSIG
Bolt Circle Diameter	12-1/16"
Flow Rate at Set	200 scfh
Position	9
Loading Ring	Set at 0°

- A. 60 PSIG inlet pressure W.O.R. 19M at 4.89 PSIG
- B. 40 PSIG inlet pressure SET
- C. 25 PSIG inlet pressure W.O.R.
- D. 40 PSIG inlet pressure - failed condition
- E. 60 PSIG inlet pressure - failed condition

Relief Monitor Curves

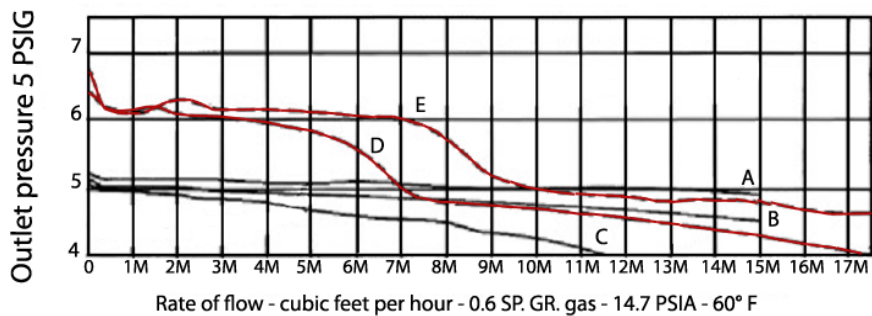

- A, B, C. Normal regulator operation.
- D, E. Main seat failed open with 1/8" x 1/2" diameter nylon disc. Internal monitor orifice in operation.

Assembly Positions

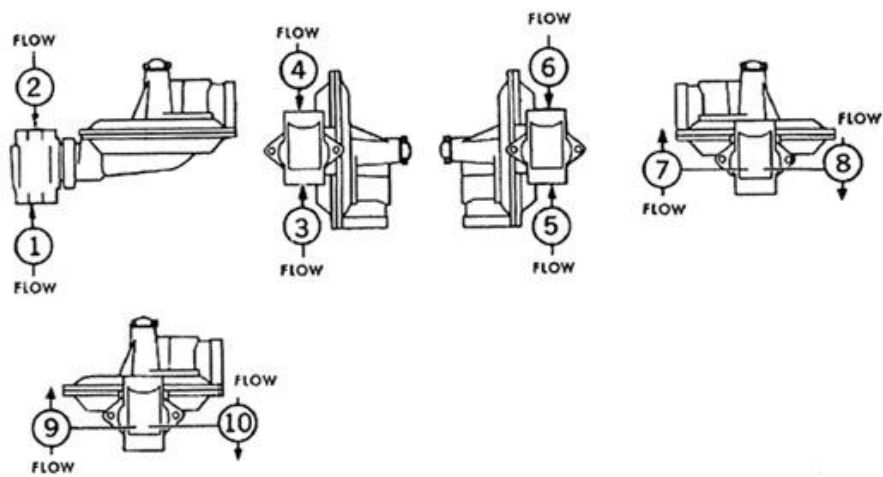

Parts List

B34 N, & R

Parts Lists

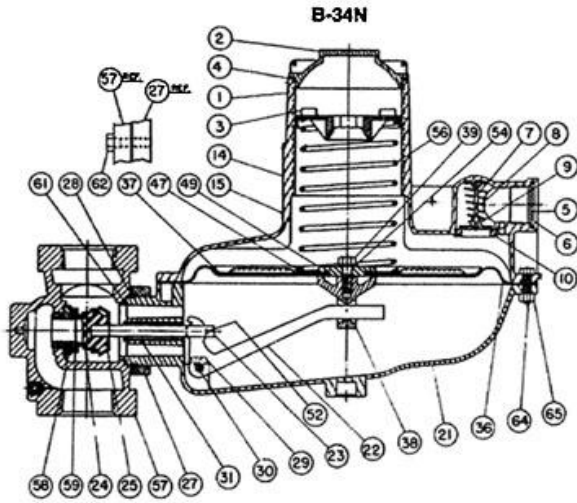

B34N Reference Schematics

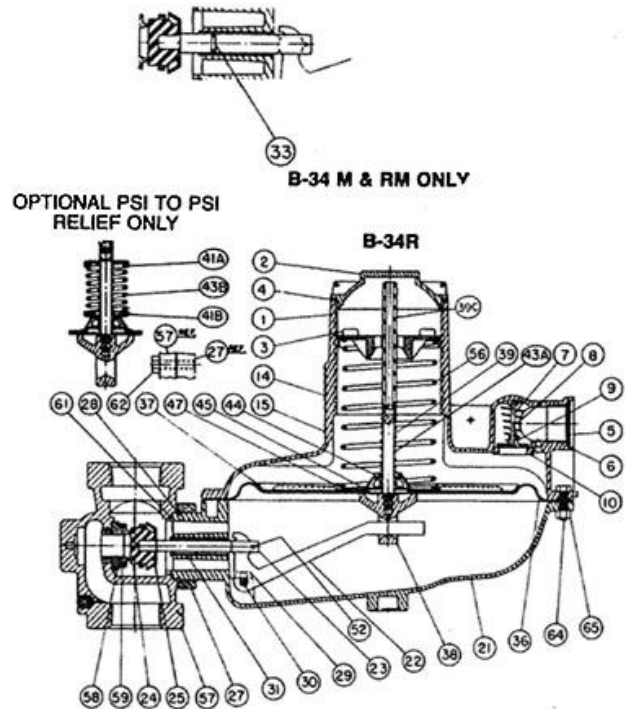

B34R Reference Schematics

Item No.	Part No.	Quantity Required per Regulator Model						Description
		RD	RM	D	M	R	N	
1								Upper diaphragm case assembly – please specify
	710040	1	1	1	1	1	1	1" NPT vent, #10 breather hole, standard
	710088	1	1	1	1	1	1	1" BSP vent, #10 breather hole
	710089	1	1	1	1	1	1	1" NPT vent, no breather hole
	710100	1	1	1	1	1	1	1" NPT vent, #44 breather hole
2	760083	1	1	1	1	1	1	Seal cap
3	760233	1	1	1	1	1	1	Adjustment screw
4	765607	1	1	1	1	1	1	Seal cap gasket
5	762933	1	1	1	1	1	1	Vent screen
6	75579101	1	1	1	1	1	1	Vent screen retainer ring
7	75483401	1	1	1	1	1	1	Vent valve disc pin
8	762601	1	1	1	1	1	1	Vent valve spring - 1/2 oz.
9	765181	1	1	1	1	1	1	Vent valve disc
10	765685	1	1	1	1	1	1	Vent valve seat
14	769250	1	1	1	1	1	1	Regulator badge
15	755071	2	2	2	2	2	2	Badge screw
21								Lower diaphragm case (use any valve body) - ratio
	715050					1	1	4:1 ratio - open throat
	715052	1	1	1	1			3.5:1 ratio - closed throat
22								Valve lever- specify ratio
	761275					1	1	4:1 ratio, standard
	761271	1	1	1	1			3.5:1 ratio

Item Number	Part Number	Quantity Required per Regulator Model						Description
		RD	RM	D	M	R	N	
23								Valve stem
	754151					1	1	Steel
	754154	1	1	1	1			Stainless steel
24								Valve seat
	765201	1	1	1	1	1	1	Valve seat Buna-N 75-80 Duro
	765203							Valve seat with white stripe Buna-N 85-90 Duro, IM version only
	765251							Valve seat with yellow strip - with IM test tap
25								Deflector ring
	761721	1	1	1	1	1	1	Deflector ring, standard
	761723	1	1	1	1	1	1	Deflector ring, IM version only
27	751913	1	1	1	1	1	1	Valve body retainer plate - aluminum
28	755725	1	1	1	1	1	1	Retainer plate snap ring
29	755223	2	2	2	2	2	2	Valve linkage pin screw
30	754836	1	1	1	1	1	1	Valve linkage pin
33	765505		1		1			Valve stem O-ring
36	766301	1	1	1	1	1	1	Diaphragm
37	76104101	1	1	1	1	1	1	Upper diaphragm plate
38								Lower diaphragm plate: please specify
	756073							With bead, R versions
	756075							No bead, N versions
39	754375	1	1			1		Stop stem - assembly self-aligning
41A	761451	1	1			1		Relief spring guide - PSI relief
41B	761431	1	1			1		Relief spring guide - use with brown & green relief spring
43		1	1			1		Relief spring: please specify:
	762301							7" w.c. above set (standard)
	762401							Brown .5 PSIG above set
	762403							Green 1.0 PSIG above set
44	754931	1	1			1		Stop stem guide bushing
45	76166501	1	1			1		Relief cap
47								Adjustment spring guide, please specify:
	761481	1	1			1		Adjustment spring guide, internal relief
	761483			1	1		1	Adjustment spring guide, non-relieving regulators
49	761081			1	1		1	Secondary diaphragm plate
52								Valve stem slot pin
	755007					1	1	Valve stem slot pin
	755009	1	1	1	1			Valve stem slot pin
54	755851							Diaphragm plate washer - lock
56		1	1	1	1	1	1	Adjustment spring, please specify:
	762351							Brown
	762353							Green
	762355							Black
	762357							Blue
	762359							Silver
	762361							Yellow
	762671							Red-Nested
	762673							White-Nested
	762321							Green/White
	762323							Silver/Red
	762365							Purple
	762341							Orange
	762345							Orange/Green
	762358							Blue/White

Item Number	Part Number	Quantity Required per Regulator Model						Description
		RD	RM	D	M	R	N	
57		1	1	1	1	1	1	NPT valve bodies - specify type & size
	750604							1-1/4" x 1-1/4"
	750605							1-1/4" x 1-1/4" BSPT
	750607							1-1/4" x 1-1/4" tap
	750616							1-1/4" x 1-1/4" IM test tap
	750627							1-1/4" x 1-1/2"
	750630							1-1/4" x 1-1/2" 1/8" tap
	750639							1-1/4" x 1-1/2" IM test tap
	750654							1-1/4" x 2"
	750657							1-1/4" x 2-1/8" tap
	750666							1-1/4" x 2" IM test tap
	750676							1-1/2" x 1-1/2"
	750678							1-1/2" x 1-1/2" BSPT
	750679							1-1/2" x 1-1/2" BSP
	750680							1-1/2" x 1-1/2" 1/8" tap
	750693							1-1/2" x 1-1/2" IM test tap
	750704							1-1/2" x 2"
	750707							1-1/2" x 2" 1/8" tap
	750716							1-1/2" x 2" IM test tap
	750726							2" x 2" NPT
	750728							2" x 2" BSPT
	750729							2" x 2" BSP
	750730							2" x 2 -1/8" tap
								Flanged valve bodies
	750754							2" x 2" ASA 125 flat-face flange 10" length
	750757							2" x 2" ASA 125 flat-face flange 10" length, 1/8" tap
	750777							2" x 2" ASA 125 flat-face flange 7.5" length
	750780							2" x 2" ASA 125 flat-face flange 7.5" length, 1/8" tap
	750804							3" x 3" ASA 125 flat-face flange
	750807							3" x 3" ASA 125 flat-face flange, 1/8" tap
58		1	1	1	1	1	1	Orifice - specify type & size
	758101							orifice 1/4"
	758104							orifice 3/8"
	758107							orifice 1/2"
	758110							orifice 5/8"
	758113							orifice 3/4"
	758117							orifice 7/8"
	758150							orifice 7/32" x 1/4"
	758151							orifice 1/4" x 3/8"
	758154							orifice 5/16" x 3/8"
	758157							orifice 3/8" x 1/2"
	758160							orifice 1/2" x 5/8"
	758163							orifice 5/8" x 3/4"
	758166							orifice 3/4" x 7/8"
	758169							orifice 7/8" x 1"
61	765651	1	1	1	1	1	1	Valve body gasket, standard
	765605	1	1	1	1	1	1	Valve body gasket, square
62	755386	2	2	2	2	2	2	Retainer plate screw 5/16-18 x 1-1/4 Hex head slotted
64	755311	12	12	12	12	12	12	Case screw - 1/4-20 x 1 Hex head
65	755513	12	12	12	12	12	12	Case screw nut - 1/4-20 Hex head

Item Number	Part Number	Quantity Required per Regulator Model						Description
		RD	RM	D	M	R	N	
Sub-assemblies								
	715016					1	1	Lower diaphragm case assembly - 4:1 lever ratio
	715018		1		1			Lower diaphragm case assembly - 3.5:1 lever ratio
	715063	1		1				Lower diaphragm case assembly - 3.5:1 lever ratio
	720025	1	1			1		Diaphragm assembly - relief (standard)
	720026							Diaphragm assembly - brown relief spring
	720027							Diaphragm assembly - green relief spring
	720028	1	1	1	1	1	1	Diaphragm assembly - 10" w.c. above set point relief spring
	720101	2	2	2	2	2	2	Diaphragm plate assembly
	756019							Lower diaphragm plate
Torque Specifications								
								Retainer plate screws
								100 in. lbs
								Orifice
								600 in. lbs
								Orifice (IM & SO)
								300 in. lbs
								Margin screws
								50 in. lbs
Special Parts								
	799021							Orifice wrench
	799055							Adjustment wrench
	799081							Loading ring position tool
	754852							Vent valve reducer #31
	754853							Vent valve reducer #44
	80002002							Seal wire, no lead 24 in.

IM Orifice Assembly Schematic

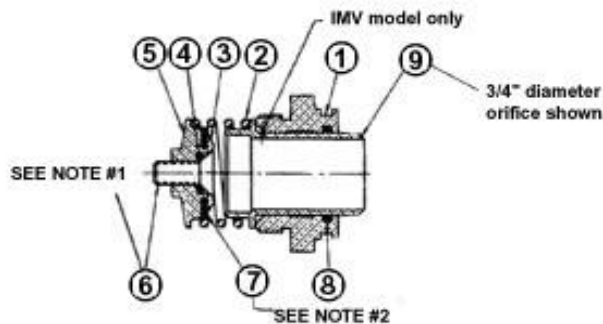

Note 1: Apply Loctite (screw-lock) to end threads of item #6 before assembling in valve body

Note 2: Cement item #7 to item #5 before assembling in valve body

SO Orifice Assembly Schematic

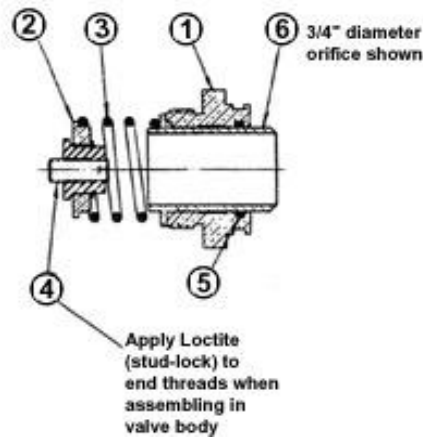

Apply Loctite (stud-lock) to end threads when assembling in valve body

Internal Monitor (IM) Orifice Assembly Numbers

759127	759125	759123	759121	Item Number	Description	Part Number
1	-	-	-	9	3/4" diameter orifice - straight	758231
-	1	-	-	9	5/8" diameter orifice - stepped	758241
-	-	-	1	9	1/2" diameter orifice - stepped	758238
-	-	-	1	9	3/8" diameter orifice - stepped	758235
1	1	1	1	8	O-ring	765501
1	1	1	1	7	Monitor seat	765741
1	1	1	1	6	Socket flat head screw	755131
1	1	1	1	5	Anchor	756103
1	1	1	1	4	O-ring	765509
1	1	1	1	3	Anchor plate	754511
1	1	1	1	2	Cut off spring	762311
1	1	1	1	1	Stationary orifice	758221

All of the above parts are interchangeable

Internal Monitor (IM) Orifice Assembly with Vent Hole "V" Option

759127	759125	759123	759121	Item Number	Description	Part Number
1	-	-	-	9	3/4" diameter orifice - straight	758251
-	1	-	-	9	3/8" diameter orifice - stepped	758255
-	-	1	-	9	1/2" diameter orifice - stepped	758258
-	-	-	1	9	5/8" diameter orifice - stepped	758261
1	1	1	1	8	O-ring	765501
1	1	1	1	7	Monitor seat	765741
1	1	1	1	6	Socket flat head screw	755101
1	1	1	1	5	Anchor	756103
1	1	1	1	4	O-ring	765509
1	1	1	1	3	Anchor plate	754511
1	1	1	1	2	Cut off spring	762311
1	1	1	1	1	Stationary orifice	758221

All of the above parts are interchangeable

Vent Lines for Regulators

When constructing vent lines to be attached to regulators installed indoors, follow a few basic rules:

- a. Never use pipe sizes smaller than the vent size; smaller pipe sizes restrict the gas flow. If a long gas run must be used, Itron advises increasing the pipe one nominal size every ten feet to keep the flow restriction as low as possible.
- b. Keep the vent line length as short as possible to minimize the restriction and reduce the vent's tendency to cause regulator pulsation.
- c. Support the vent pipe to eliminate strain on the regulator diaphragm case.
- d. Always point outdoor vent pipes in the downward position to reduce the possibility of rain, snow, sleet, and other moisture entering the pipe. Install a bug screen in the end of the pipe.
- e. Do not locate the vent line terminus near windows, fans, or other ventilation equipment. See the installation instructions furnished with the regulator.
- f. Adhere to all applicable codes and regulations.
- g. If your vent pipe causes regulator pulsation, consult your sales representative or manufacturer.
- h. Itron strongly recommends running a separate vent line for each regulator. Headers with various installed devices can cause regulator malfunction.

Caution Ensure the end of the vent line is away from ANY potential ignition sources. It is the installer's responsibility to ensure the vent line is exhausting to a safe environment.

Installation

Warning Itron does not endorse or warrant the completeness or accuracy of any third party regulator installation procedures or practices, unless otherwise provided in writing by Itron. Follow your company's standard operating procedures regarding the use of personal protection equipment (PPE). Adhere to guidelines issued by your company in addition to those given in this document when installing regulators.

- a. Remove all shipping plugs from the regulator inlet, outlet, and vent before installation.
- b. Verify the piping interior and regulator inlet and outlet are clean and free of dirt, pipe dope, and other debris. Dirt and other foreign materials entering the regulator can cause a loss of pressure control.
- c. Apply pipe joint sealant to the male pipe threads. Do not use pipe joint material on the regulator's female threads. Joint sealant may become lodged in the regulator and cause a loss of pressure control.
- d. Gas must flow through the regulator's valve body in the direction cast on the regulator body. Gas flowing in the wrong direction can overpressure and cause damage to the regulator.
- e. The diaphragm casing can be mounted in any position relative to the body through a full 360° angle at 90° increments.
- f. When the regulator is installed OUTDOORS, the vent must always be positioned so that rain, snow, moisture or foreign particles cannot enter the vent opening. Itron recommends positioning the vent downward to avoid entry of water or other matter which could interfere with the proper operation of the regulator. The vent should be located away from building eaves, window openings, building air intakes and above the expected snow level at the site. Inspect the vent opening periodically to insure it does not become blocked by foreign material as outlined in DOT PHMSA-RSPA-2004-19856.
- g. When the regulator is installed INDOORS, the vent must be piped to the outside atmosphere using the shortest length of pipe, the fewest possible pipe elbows, and a pipe diameter as large as the vent size or larger. USING VENT PIPE SMALLER THAN THE VENT CONNECTION LIMITS THE REGULATOR'S INTERNAL RELIEF VALVE CAPACITY. The outlet end of the pipe must be protected from moisture and the entrance of foreign particles. The regulator should be specified by the user with the size vent and pipe threads desired to make the vent pipe connection.

Start-up Procedure

- a. Mount a pressure gauge downstream of the regulator to monitor the downstream pressure.
- b. With the downstream pressure valve closed, slowly open the inlet valve. The outlet pressure should rise to slightly more than the set-point. Verify there are no leaks and all connections are tight.
- c. The regulator was pre-set at the factory to match order specifications. If necessary, adjust the outlet pressure by removing the seal cap on the top of the pilot spring housing and adjusting the ferrule or screw inside the spring housing using a large flat-head screwdriver. With a small amount of gas flowing through the regulator, rotate the ferrule clockwise to raise the outlet pressure or counter-clockwise to lower the outlet pressure.
- d. Replace the seal cap and check for leaks after the desired outlet pressure is achieved.

The regulator is ready for operation.

Safety Warning

This product, as of the date of manufacture, is designed and tested to conform to all governmental and industry safety standards as they may apply to the manufacturer. The purchaser/user of this product must comply with all fire control, building codes, and other safety regulations governing the application, installation, operation, and general use of this regulator to avoid leaking gas hazards resulting from improper installation, startup or use of this product.

Itron strongly recommends installation by a qualified professional and periodic inspection of pressure regulators (inspections may be required by local applicable codes or regulations).

Inspections should include checking for gas quality, cycle numbers, external environmental changes, and operating conditions that impact wear on the regulator's moving parts. To ensure safe and efficient operation of this product, replace worn or damaged parts found during inspection.

Limited Warranty

Itron, Inc. 970 Highway 127 North, Owenton, Kentucky 40359-9302, warrants this gas product against defects in materials and workmanship for the earlier of one (1) year from the date the product is shipped by Itron or a period of one year from the date the product is installed by Itron at the original purchaser's site. During such one-year period, provided that the original purchaser continues to own the product, Itron will, at its sole option, repair any defects, replace the product or repay the purchase price.

- > This warranty will be void if the purchaser fails to observe the procedures for installation, operation or service of the product as set forth in the Operating Manual and Specifications for the product or if the defect is caused by tampering, physical abuse or misuse of the product.
- > ITRON SPECIFICALLY DISCLAIMS ALL IMPLIED WARRANTIES INCLUDING THOSE OF MERCHANTABILITY OR OF FITNESS FOR A PARTICULAR PURPOSE. UNDER NO CIRCUMSTANCES WILL ITRON BE LIABLE FOR INCIDENTAL OR CONSEQUENTIAL DAMAGES OF ANY KIND WHATSOEVER.
- > Itron's liability for any claim of any kind, including negligence and breach of warranty for the sale and use of any product covered by or furnished, shall in no case exceed the price allocable to the product or part thereof which gives rise to the claim.

- > In the event of a malfunction of the product, consult your Itron Service Representative or Itron Inc., 970 Highway 127 North, Owenton, Kentucky 40359-9302. See Itron Terms and Conditions of Sale for the full and complete terms of the Limited Warranty.

Ordering Information

Specify:

1. Inlet and Outlet Connection Size and Type
2. Model Number
3. Outlet pressure desired
4. Pilot needed
5. Inlet pressure range
6. Type of gas and maximum capacity required
7. Assembly position number (see chart below)
8. Special requirements such as tagging, 1/8" pipe plug tap, seal wire, etc.

About Itron Inc.

Itron Inc. is a leading technology provider to the global energy and water industries. Our company is the world's leading provider of metering, data collection and utility software solutions, with nearly 8,000 utilities worldwide relying on our technology to optimize the delivery and use of energy and water. Our products include electricity, gas and water meters, data collection and communication systems, including automated meter reading (AMR) and advanced metering infrastructure (AMI); meter data management and related software applications; as well as project management, installation, and consulting services. To know more, start here: www.itron.com



Itron Gas

970 Highway 127 North
Owenton, Kentucky 40359
USA
Phone: 1.800.490.0657
1.502.484.5747
fax: 1.502.484.6223

Corporate Headquarters

2111 North Molter Road
Liberty Lake, WA 99019
USA
Phone: 1.800.635.5461
Fax: 1.509.891.3355
www.itron.com