

BAILEY[®]
TOTAL BUILDING ENVELOPE

CI/SfB

Oct 12

(47)

Ln

Uniclass L524



System 17000

HIGH PERFORMANCE, TORCH-ON ROOFING SYSTEM
RESILIENT, FLEXIBLE, LONG LASTING

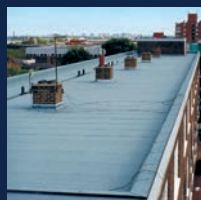
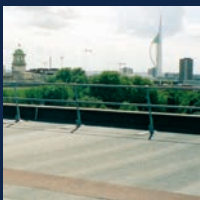

Bailey System 17000

High performance, superior quality



Bailey System 17000 is a superior, torch-on, waterproofing system for flat and pitched roofs. Manufactured with an untearable spun bond polyester carrier coated in APP (atactic polypropylene) modified bitumen, System 17000 HAS resistance to UV light and a life expectancy in excess of 30 years. Certificated by BBA and carrying an insurance-backed guarantee, System 17000 is a secure choice FOR flat roofS.



THE BAILEY 17000 ROOFING SYSTEM OFFERS THE FOLLOWING BENEFITS:

- longer-lasting, high quality waterproofing
- better 'whole life costing' compared to low quality systems
- more value for money as minimal maintenance is required

Bailey Roofing Systems has been involved with flat roofing for over 30 years. From the beginning, their commitment has been to supply only the best quality materials offering the longest life expectancy and performance available. Bailey's range of products and depth of knowledge in the industry allow the specifier to select the system best suited to the flat roof project.

System

System 17000 – proven track record

As a result of continuous development and improvement, Bailey has brought effective and innovative systems to the market place, including flame-free and sustainable single layer systems. System 17000 being a proven roofing system with a track record going back to 1985, is well established in the Bailey range and successful in the flat roof market. System 17000 is best suited to projects where a high performance product is required - installed using effective and traditional methods.

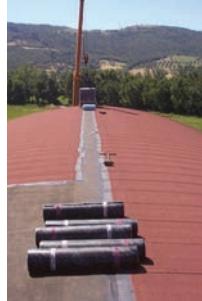

Quality Manufacture

Since the 1950's and 60's, when flat roofing had a poor reputation, there have been great advances in roofing. Gone are the days when weak materials, poor carriers and oxidised bitumen were acceptable. Bailey have supplied only high performance products that are simple to install and offer a long lasting flat roof.

Bailey System 17000 is a high performance product, with a spun bond polyester carrier and APP modified bitumen. The secret of an excellent product is the blending of the right proportions of bitumen, plasticisers and fillers. System 17000 is manufactured using the latest technology and is continually monitored. The manufacturing process is subject to stringent quality control, in accordance with ISO9001. A sample from every batch is tested and retained in the laboratory for nine months and each roll bears a label with the batch number giving full traceability. The manufacturing plant has been extensively upgraded and modernised over the years and is now fully automated.

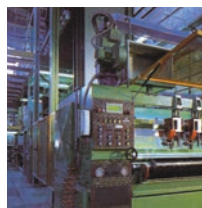

17000



Experienced Installation

Bailey System 17000 is installed only by recommended contractors who are experienced and trained in installation of torch-on products. To ensure workmanship is up to Bailey's required standard of excellence in flat roofing, a series of site inspections are carried out during the course of the installation. Bailey's Technical Personnel assist and advise with detailing and laying of the system, resulting in a successful installation. On completion of the project, prior to issue of the guarantee, a final inspection is carried out, usually accompanied by the client or his representative surveyor, to ensure a satisfactory result.

Water-tight Guarantee

System 17000 is available with a 15 year insurance-backed guarantee. On some projects, subject to payment of an additional premium on supply of the materials, it is possible to extend the guarantee to 20 years.

The guarantee is one of the best available, as it covers not only replacement of faulty materials, but correction of faulty installation and consequential damage to contents of buildings.

The guarantee is provided by an internationally recognised insurance company with UK offices and is not subject to payment of an annual fee by either the client or the manufacturer to ensure its validity. It is purchased by the manufacturer in the year of inception and is therefore independent of either the continuance of the contractor, the importer or the manufacturer.

To qualify for an insurance-backed guarantee, it is essential that Bailey are given details of the project at the onset and either approve or provide the specification. Details of recommended installers will be provided and it will be necessary for interim and final inspection reports to be issued by Bailey Technical Personnel.

Technical information

Characteristics	Test method UEAtc	Unit of Measure	System 17000: Typical values		
			Underlay	Sanded Capsheet	Mineral Capsheet
Thickness	A	mm	3	4	4
Roll length	–	m	10	10	10
Roll width	–	cm	100	100	100
Mass	B	Kg/m ²	3,3	4,2	4,5
Tensile strength (1)	C	N/5cm	L=800	L=900	L=900
Tensile strength (1)	C	N/5cm	T=550	T=650	L=650
Elongation (1)	C	%	L=40	L=45	L=45
Elongation (1)	C	%	T=45	T=45	T=45
Resistance to tear (1)	5.4.1	N	L=120	L=140	L=140
Resistance to tear (1)	5.4.1	N	T=120	T=140	T=140
Static puncture on hard support	5.1.9	L*	L4	L4	L4
Static puncture on insulation board	5.1.9	L*	L4	L4	L4
Cold flexibility	D	°C	-15	-15	-15
Dimensional stability	5.1.6.1	%	L=0,5	L=0,5	L=0,5
Heat resistance	E	°C	130	130	130
Water tightness	5.1.4	KPa (2)	60 KPa	60 KPa	60 Kpa
Water vapour permeability	5.1.11	g/m ² /day	<=0,1	<=0,1	<=0,1
Water vapour permeability (3)	–	–	0,63	0,68	0,54
Water vapour resistance (3)	–	–	326	302	380

System

Standard details

DRIP EDGE

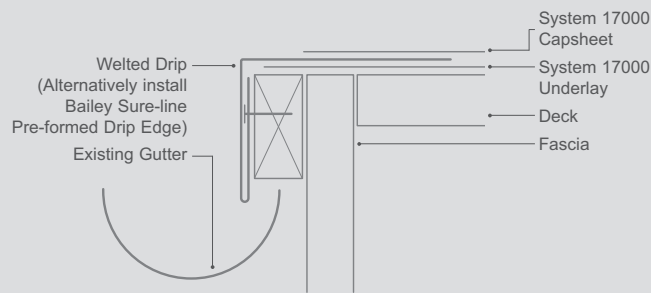

WATERCHECK

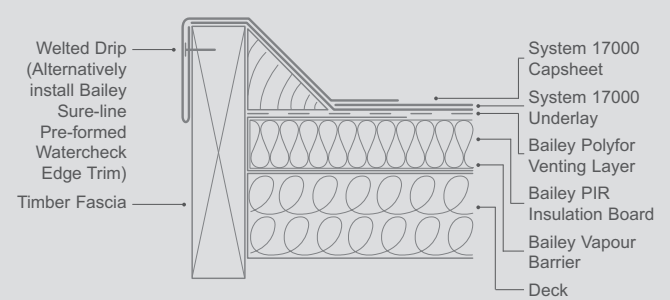

COLD PIPE

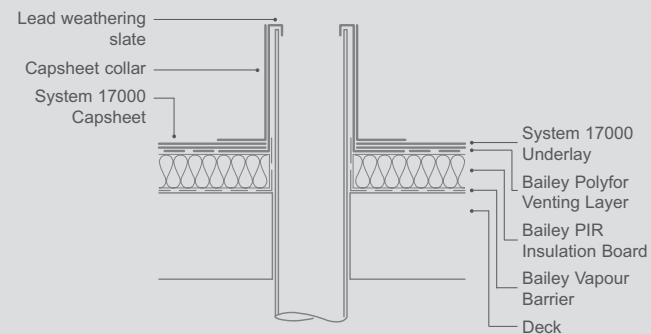

UPSTAND FLASHING

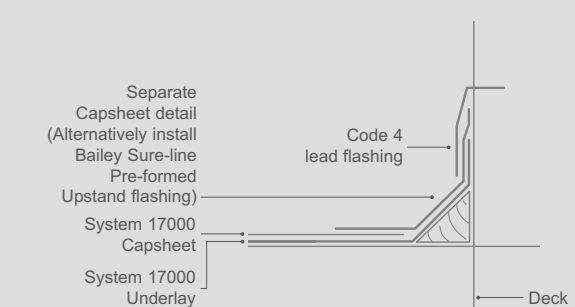

Flexible Specifying

Bailey System 17000 can be used for many types of roof, including flat, pitched and barrel vaulted. The design flexibility of the system enables it to be used on waveform roofs or those with a unique design and shape.

As every flat roof project is different, it is essential that the right system is selected. At Bailey, as well as having a solution to almost every flat roof situation, their experience of over 30 years in the industry, is made available at every stage. Bailey advise involvement at the very earliest design stage of a project to ensure the best results. Bailey Technical Personnel are able to receive architects plans of new build projects or carry out a detailed survey (including a core sample) with a comprehensive report, for repair or

refurbishment. Following this, a specification can be provided, recommending the most suitable system. Bailey's recommendation will offer the best solution within the budget without cutting corners or compromising on quality.

Once a system has been specified, Bailey will provide names of recommended contractors who will be willing to tender for the works. Projects are policed by Bailey and reports of inspections produced. On completion of the works, a final inspection is carried out, the job signed off and the guarantee issued.

Worldwide Success and Approvals

Bailey System 17000 has been produced since 1982. It is now exported to 20 countries worldwide and has proved to give satisfactory service in some of the coldest Scandinavian countries, as well as some of the hottest countries in the Middle East. Many approvals have been obtained and there are countless examples of successful installations. Some of the approvals achieved are:

- BBA Certificate in UK (first obtained in 1994)
- ITC in Italy
- ITB in Poland
- FM approval is available on a similar, alternative range

To draw on Bailey's expertise and for further assistance and advice, call the Technical Sales Department on:

01444 244330

17000



The Complete System

Whatever the specification, Bailey can supply the 'complete' system together with expert advice, assistance and recommendations.

Bailey Laminated Vapour Barrier

An aluminium cored, torch bonded product, providing an effective vapour barrier as opposed to a vapour check. In addition, the top surface can be torched to rapidly adhere the insulation boards, eliminating the need for hazardous bitumen boilers, thus improving health and safety on site.

Bailey PIR Insulation Boards

Environmentally friendly, highly efficient polyurethane board, containing no CFCs or HCFCs. Tapered insulation schemes are available to help reduce ponding which is common on many older flat roofs.

Bailey Polyfor Venting Layer

Specially designed to be used with torch-on systems, allowing the free movement of trapped vapours which prevents blistering.

Bailey System 17000 Underlay

A spun bond polyester reinforced underlay with APP modified bitumen. The underlay can be torched both sides and either fully or partially bonded to the substrate.

Bailey System 17000 Mineral Capsheet

A 4.5kg/m² capsheet, again with a tough spun bond polyester carrier and APP modified bitumen - providing extra resistance to UV light. The surface is finished with a green mineral giving added protection.

Bailey System 17000 Sanded Capsheet

An alternative cap sheet which is 4mm thick and can be used unprotected or in conjunction with various types of solar reflective coatings or chippings.



PLEASE ENQUIRE ABOUT OUR COMPREHENSIVE RANGE OF BAILEY ROOFING SYSTEMS:

- Bailey Atlantic Sustainable Single Ply
- Bailey System 5000 Flame -Free Felt System
- Bailey Classic (SBS) Commodity Range
- Bailey System 12000 (APP) Commodity Range
- Bailey Sure-Line Preformed Roof Edging System

System

Bailey System 17000 Specifications

Plywood deck (cold roof)

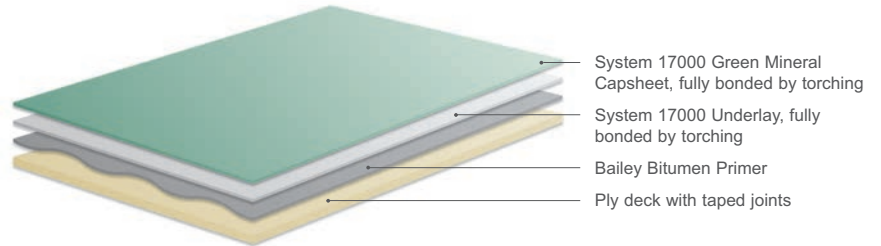

Concrete deck / Asphalt overlay (cold roof)

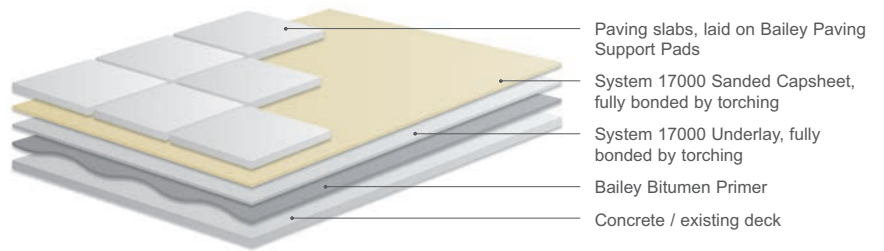

Profile metal deck (warm roof)

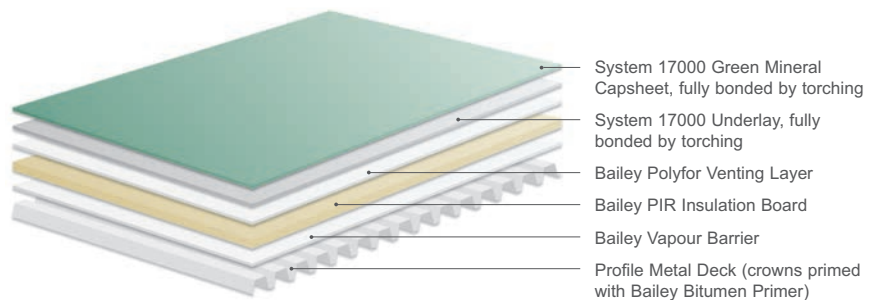

17000



UK office Blatchford Close Horsham West Sussex RH13 5RF

Tel +44 (0)1403 261844 **Email** sales@bailey-uk.com **www.bailey-uk.com**

European office **Tel** +31 (0)88 100 3800 **Email** sales@bailey-eu.com **www.bailey-eu.com**