

Rotary Joints

Series H

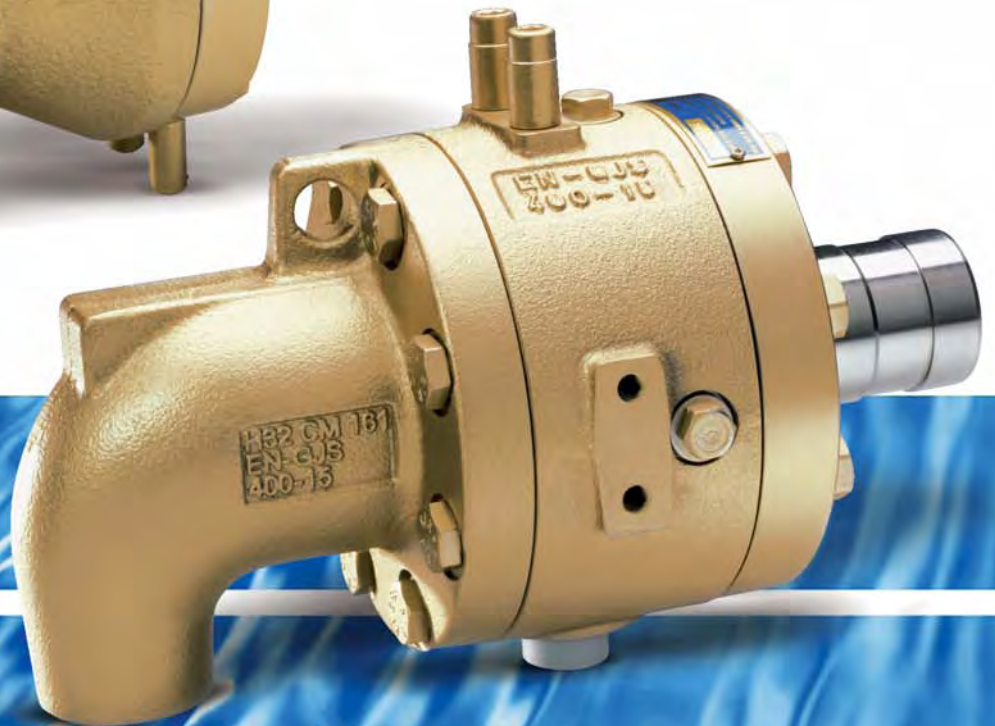

Rotary Joints Series H

Standard series H and HW are designed up to Nominal Diameter 100 mm (4") to accommodate transfer of water, steam and thermal oil under temperature, rotation and pressure.

Furthermore the heavy duty designs HWA, HWB, HWX are designed for higher speeds and higher loads and bigger diameters.

A flexible modular system with housing flange and gasket connections, which can be subsequently modified.

Operating manuals are available at www.maier-heidenheim.de or directly from our works. Our sales staff will be happy to provide you with user identification and password. After placing an order you will find this information on the delivery note.



Standard Series

- Housing made of ductile cast iron, cover and rotor made of chrome steel, rotors for Nominal Diameter 65 mm (2 1/2") and above made of steel, sealing face made of chrome steel. High-temperature resistant spring made of stainless steel.
- Sealing ring of compression-loaded wear-resistant graphite carbon. Due to its design, it is, unlike others, and is shatter-proof under high pressure. Series HW with metal-impregnated graphite carbon, is especially suitable for thermal oil and for considerably higher pressures, temperatures and speeds. The bearing is secured against rotation. Slide bushing is used as gap seal for rotating inner pipe. There is a wear indicator for the sealing ring at the rotor.
- Easy to repair. Maintenance-free, no relubrication required.
- Connection to rotating pressurised system by means of:
 - Standardised connecting piece with right-hand or left-hand male thread BSP (ISO 228). Sealing and centring cone at end of thread. Adapter pieces for NPT and other threads are available.
 - K flange with conical inner ring – quick disconnect (must be ordered separately).
- Radial and axial housing connection with right-hand thread BSP (ISO 228). Adapter pieces available for NPT and other threads as well as for flange connections.
- According to safety regulations DIN 4757, sealing in the thread is not admissible when using thermal oil. We recommend using flange connections. Screw thread for fixed inner pipe is always right-handed, even when thread on rotor is left-handed.
- Rotation of the housing is prevented by means of the anti-rotating fork on the cover, where the locking bolt engages. Thermal expansion of the roller and wear of seals and bearing cause an axial displacement of the housing (away from the roller). Anti-rotation device, hose connection and inner pipe must not impede this axial displacement. Otherwise the rotary joint will not operate or seal properly.

The fortified designs HWA, HWB, HWX are

- More robust
 - Greater distance between bearings, double-sized cover bushing, two large bearings from Nominal Diameter 80 mm (3") and above.
 - Anti-rotation device between the bearings ensures low moment of friction.
 - Housing flange connection is sealed with a gasket, no soldering.
- Faster
 - Up to 50 % higher speed possible.
- More flexible
 - Modular system: please specify required – position when placing the order.
 - Housing flanges can be screwed in later.



The different designs are equipped as follows:

- Housing of ductile cast iron, HWA Nominal Diameter 100 mm (4") and above of steel in welded design.
- Rotor of stainless steel 1.4571 (316) or carbide coated carbon steel. All other steel parts in stainless steel.
 - Metal-impregnated sealing ring, suitable for high pressure.
 - Housing bearing secured against rotation.
 - Connection to the rotating pressurised system by means of K-flange and conical inner ring (quick disconnect).
 - Radial and axial housing connections with right-hand thread to ISO 228. As an option, Nominal Diameter DN 32-100 (1 1/4" - 4") with screw flange and gasket PN 40 DIN 2656; Nominal Diameter DN 100-300 (4" - 12") with welded flanges PN 40 DIN 2635. For Nominal Diameter DN 15-25 (1/2" - 1"), we offer metal hoses sealed with a gasket, since housing flanges would be too heavy for this purpose.
 - According to safety regulations DIN 4757, sealing in the thread is not admissible when using thermal oil.
 - Rotation of the housing is prevented by means of the anti-rotating fork at the housing, where the locking bolt engages.
- From Nominal Diameter DN 100 (4"), the unit weight is to be partially supported by means of the housing lug.
- Great number of different designs:
 - HW1, 2, R2 – 450. Based on standard basic design, however suitable for higher loads with rotors made of stainless steel 1.4571 (316) or carbide coated carbon steel.
 - HW1 – 500 and HWA, B, X2 – 500. Based on standard basic design (HW 1) and on fortified design (HWA, B, X), however suitable for higher loads with rotors made of stainless steel 1.4571(316) or carbide coated steel, with screw flanges, sealed with gasket, PN 40 DIN 2656.
 - HWX for stationary inner pipe, right-hand thread.
 - HWB for rotating inner pipe, bearing bush rotating with rotor, no wear. Gap seal, suitable for liquids, low pressure loss between flow and return.
 - HWA for rotating inner pipe, bearing bush rotating with rotor, no wear. Bearing shrunk into stainless steel bushing. Bearing bush/rotor and bearing are sealed with O-ring. Suitable for steam and high pressure loss between flow and return. HWA for big Nominal Diameter > 100 (4") in welded design.

Application data

Series		H	HW	HW -450		HW		
Design		1, 2, R2, 3	1, 2, R2, 3	1		X2, A2		
Nominal diameter DN	mm	15...100	15...100	15...25		32...100		
Design				2, R2				
Nominal diameter DN	mm			20 + 25				
Medium		Water Steam	Thermal oil	Water Steam	Thermal oil	Water Steam	Thermal oil	Wa
Temperature	min...max °C	-10...220	-10...300	-10...250	-10...300	-10...230	-10...300	-10..
Pressure PN	min...max bar	0,8...20	0,8...10	0,8...20	0,8...10	0,8...28	0,8...10	0,8..
Speed	max. min ⁻¹	<u>50.000</u> (DN x PN)	<u>100.000</u> (DN x PN)	<u>100.000</u> (DN x PN)	<u>100.000</u> (DN x PN)	<u>150.000</u> (DN x PN)	<u>150.000</u> (DN x PN)	<u>150.</u> (DN x

Overspeed limitation

DN		15	20	25	32	
Speed	max. min ⁻¹	470	400	340	420	

* For DN 200 + 300 max. 200° C, 16 bar. Series H3 with vacuum breaker. Designs for higher values and media on request. The combination of maximum values should be avoided.

Ordering instructions

Example:

H W X 2 32 K -500

Series H	
W High-performance sealing ring, metal-impregnated	
X Design for screwed stationary inner pipe	
R rotating inner pipe with slide bushing and gap seal in the housing	
B rotating inner pipe with gap seal between flow and return	
A rotating inner pipe with complete sealing between flow and return	
1 Number of housing connections for one way flow design	
2 for two way flow design	
3 for two way flow design with vacuum breaker	
Nominal diameter in mm (≙ dimension A) 15, 20, 25, 32, 40, 50, 65, 75, 80, 100, 125, 150, 200, 300	
R Rotor connection for right-hand thread	
L for left-hand thread	
K for K flange	Adapters for other threads are available, upon request.
Consecutive numbers for special designs; numbering by factory. Exceptions: variant -450 without flange connections; variant -500 with screw flanges.	

HW		HW -500		HW -500		HW -500		HW	
B2 32...100		1 32...100		X2, A2 32...100		B2 32...100		1 125...300 A2 100...300	
Water	Thermal oil	Water Steam	Thermal oil	Water Steam	Thermal oil	Water Steam	Thermal oil	Water Steam	Thermal oil
125...230 0,8...28	-10...300 0,8...10	-10...250 0,8...20	-10...300 0,8...10	-10...230 0,8...28	-10...300 0,8...10	-10...230 0,8...28	-10...300 0,8...10	-10...210* 0,8...20*	-10...300 0,8...10
150.000 (DN x PN)	150.000 (DN x PN)	100.000 (DN x PN)	100.000 (DN x PN)	150.000 (DN x PN)	150.000 (DN x PN)	150.000 (DN x PN)	150.000 (DN x PN)	150.000 (DN x PN)	150.000 (DN x PN)
40	50	65	75	80	100	125	150	200	300
370	350	300	250	250	200	100	80	60	30

Assembly by modular system for HWX – HWB – HWA DN 32-100

When placing the order, please copy this page, fill in the blanks and send it by fax to **+49 7321 317-139**.

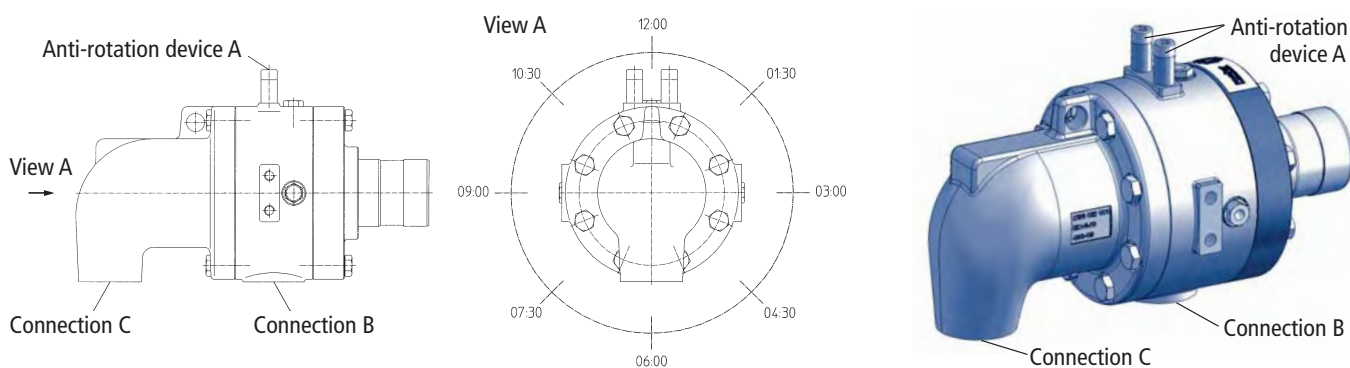

Customer

Order number

Connection B	Anti-rotation device A	Connection C
06:00	03:00	01:30
	09:00	03:00
	12:00	04:30
		06:00
		07:30
		09:00
		10:30
		12:00

Orientation of connection B always in 6 o'clock position. Line of sight to the rotary joint: view A (from the rear).

Please tick required positions of anti-rotation device A and connection C. The ordered rotary joint will be assembled according to these details.

H1 + HW1 DN 15-100

for one way flow of a medium

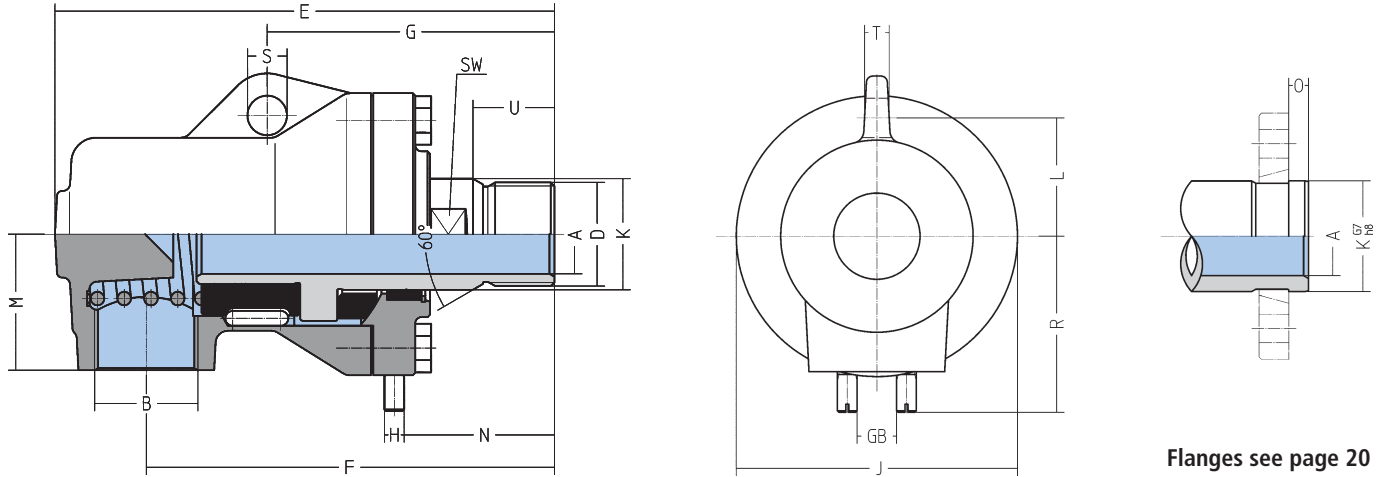

DN	15	20	25	32	40	50	65	80	100	
H	Type	H 115 R	H 120 R	H 125 R	H 132 R	H 140 R	H 150 R	H 165 R	H 180 R	H 1100 R
	Order-No.	1108050	1108130	1108210	1108350	1108450	1108550	1108650	1108750	1108850
H	Type	H 115 L	H 120 L	H 125 L	H 132 L	H 140 L	H 150 L	H 165 L	H 180 L	H 1100 L
	Order-No.	1108051	1108131	1108211	1108351	1108451	1108551	1108651	1108751	1108851
H	Type	H 115 K	H 120 K	H 125 K	H 132 K	H 140 K	H 150 K	H 165 K	H 180 K	H 1100 K
	Order-No.	1108052	1108132	1108212	1108352	1108452	1108552	1108652	1108752	1108852
HW	Type	HW 115 R	HW 120 R	HW 125 R	HW 132 R	HW 140 R	HW 150 R	HW 165 R	HW 180 R	HW 1100 R
	Order-No.	1108065	1108145	1108165	1108366	1108465	1108565	1108665	1108765	1108865
HW	Type	HW 115 L	HW 120 L	HW 125 L	HW 132 L	HW 140 L	HW 150 L	HW 165 L	HW 180 L	HW 1100 L
	Order-No.	1108066	1108146	1108166	1108367	1108466	1108566	1108666	1108766	1108866
HW	Type	HW 115 K	HW 120 K	HW 125 K	HW 132 K	HW 140 K	HW 150 K	HW 165 K	HW 180 K	HW 1100 K
	Order-No.	1108067	1108147	1108169	1108368	1108467	1108567	1108667	1108767	1108867

Ø A	13	20	25	32	38	50	66	81	98
B	G 1/2	G 3/4	G 1	G 1 1/4	G 1 1/2	G 2	G 2 1/2	G 3	G 4
D	G 1/2 A	G 3/4 A	G 1 A	G 1 1/4 A	G 1 1/2 A	G 2 A	G 2 1/2 A	G 3 1/2 A	G 4 A
E	132	148	174	203	226	275	327	398	480
F	109	122	143	167	183	225	264	320	383
G	87	93	104	118	124	146	165	203	243
H	7	8	8	10	11	13	18	18	25
Ø J	80	88	97	114	124	144	182	220	260
Ø K	25	30	35	45	52	66	85	107	118
Ø K G7/h8	24	30	35	45	50	65	85	105	114
L	31	36	40	48	53	62	80	100	115
M	34	42	48	55	65	80	90	115	135
N	47	50	53	62	66	82	93	121	143
O	6	8	8	8	10	10	10	12	12
R	46	50	54	65	70	81	101	121	143
S	12	12	14	16	16	18	20	22	26
T	7	8	9	10	12	13	15	20	22
U	23	23	28	33	36	43	48	54	66
SW	22	27	30	41	46	60	75	95	110
Weight (kg)	1,7	2,4	3,4	5,5	7,1	11,3	21,4	37,9	62

H2 + HW2 DN 15-100

for two way flow of a medium
designed for non-rotating inner pipe

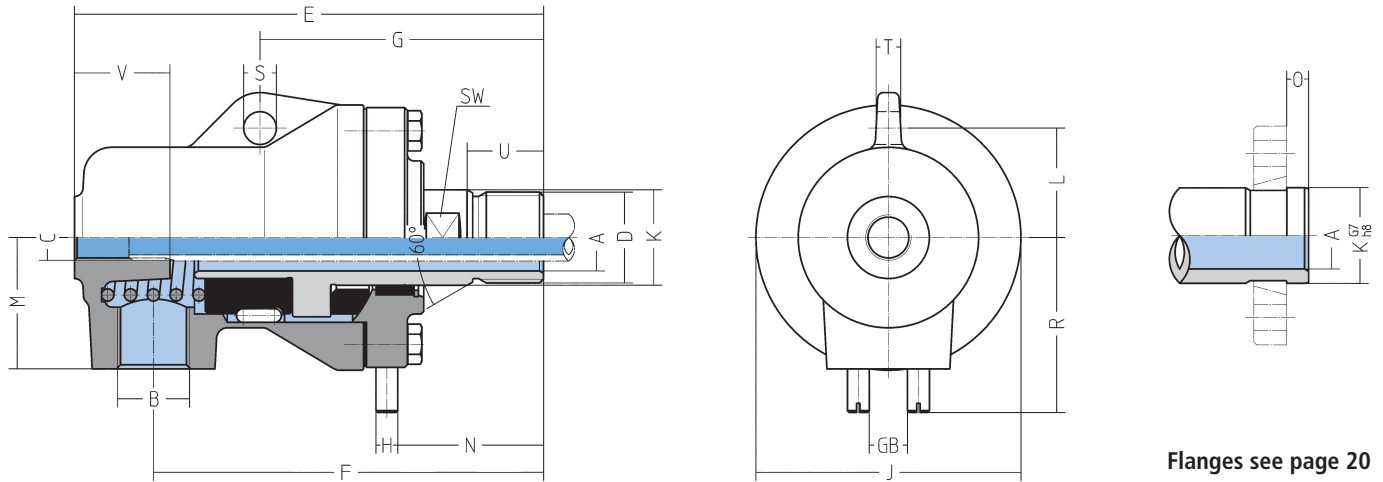

DN	15	20	25	32	40	50	65	80	100
Type	H 215 R	H 220 R	H 225 R	H 232 R	H 240 R	H 250 R	H 265 R	H 280 R	H 2100 R
Order-No.	1108053	1108133	1108213	1108353	1108453	1108553	1108654	1108753	1108853
Type	H 215 L	H 220 L	H 225 L	H 232 L	H 240 L	H 250 L	H 265 L	H 280 L	H 2100 L
Order-No.	1108054	1108134	1108214	1108354	1108454	1108554	1108655	1108754	1108854
Type	H 215 K	H 220 K	H 225 K	H 232 K	H 240 K	H 250 K	H 265 K	H 280 K	H 2100 K
Order-No.	1108055	1108135	1108215	1108355	1108455	1108555	1108656	1108755	1108855
Type	HW 215 R	HW 220 R	HW 225 R	HW 232 R	HW 240 R	HW 250 R	HW 265 R	HW 280 R	HW 2100 R
Order-No.	1108068	1108148	1108167	1108363	1108468	1108568	1108668	1108768	1108868
Type	HW 215 L	HW 220 L	HW 225 L	HW 232 L	HW 240 L	HW 250 L	HW 265 L	HW 280 L	HW 2100 L
Order-No.	1108069	1108149	1108168	1108364	1108469	1108569	1108669	1108769	1108869
Type	HW 215 K	HW 220 K	HW 225 K	HW 232 K	HW 240 K	HW 250 K	HW 265 K	HW 280 K	HW 2100 K
Order-No.	1108070	1108150	1108170	1108365	1108470	1108570	1108670	1108770	1108870

Ø A	13	20	25	32	38	50	66	81	98
B	G 3/8	G 1/2	G 3/4	G 1	G 1 1/4	G 1 1/2	G 2	G 2 1/2	G 3
C	G 1/8	G 1/4	G 3/8	G 1/2	G 3/4	G 1	G 1 1/2	G 1 1/2	G 2
D	G 1/2 A	G 3/4 A	G 1 A	G 1 1/4 A	G 1 1/2 A	G 2 A	G 2 1/2 A	G 3 1/2 A	G 4 A
E	130	146	172	200	223	272	324	393	475
F	109	122	143	167	183	225	264	320	383
G	87	93	104	118	124	146	165	203	243
H	7	8	8	10	11	13	18	18	25
Ø J	80	88	97	114	124	144	182	220	260
Ø K	25	30	35	45	52	66	85	107	118
Ø K G7/h8	24	30	35	45	50	65	85	105	114
L	31	36	40	48	53	62	80	100	115
M	34	42	48	55	65	80	90	115	135
N	47	50	53	62	66	82	93	121	143
O	6	8	8	8	10	10	10	12	12
R	46	50	54	65	70	81	101	121	143
S	12	12	14	16	16	18	20	22	26
T	7	8	9	10	12	13	15	20	22
U	23	23	28	33	36	43	48	54	66
V	28	32	35	45	50	60	70	80	90
SW	22	27	30	41	46	60	75	95	110
Weight (kg)	1,6	2,3	3,2	5,3	6,9	11,1	21,3	37,1	61

HR2 + HWR2 DN 15-100

for two way flow of a medium
designed for rotating inner pipe

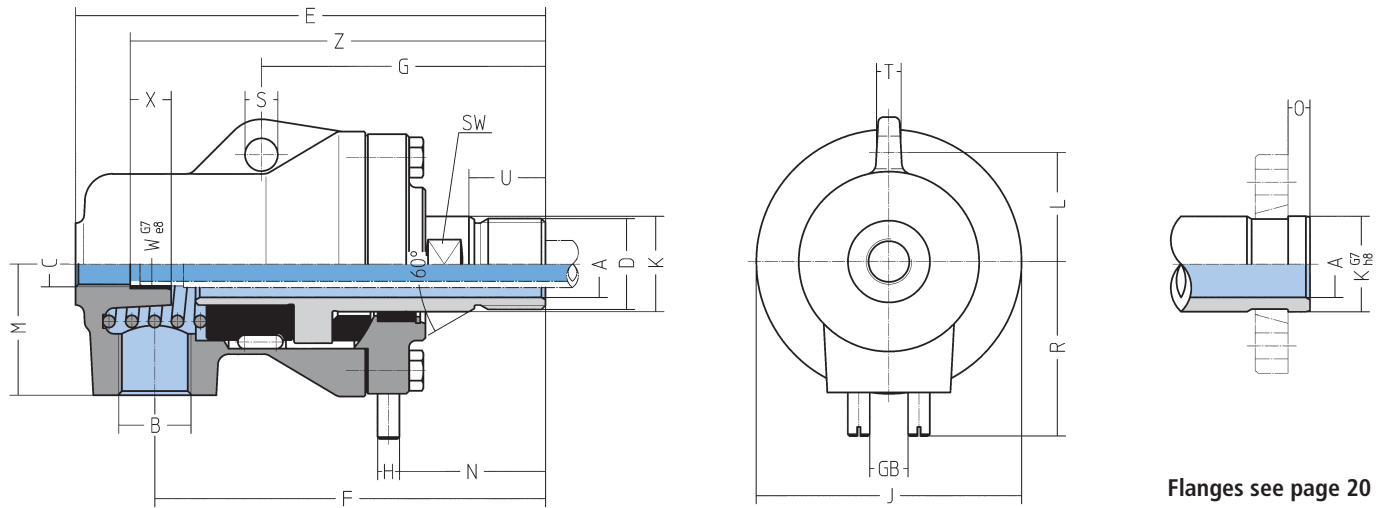

DN	15	20	25	32	40	50	65	80	100
Type	HR 215 R	HR 220 R	HR 225 R	HR 232 R	HR 240 R	HR 250 R	HR 265 R	HR 280 R	HR 2100 R
Order-No.	1108056	1108136	1108219	1108359	1108459	1108556	1108657	1108756	1108856
Type	HR 215 L	HR 220 L	HR 225 L	HR 232 L	HR 240 L	HR 250 L	HR 265 L	HR 280 L	HR 2100 L
Order-No.	1108057	1108137	1108220	1108360	1108460	1108557	1108658	1108757	1108857
Type	HR 215 K	HR 220 K	HR 225 K	HR 232 K	HR 240 K	HR 250 K	HR 265 K	HR 280 K	HR 2100 K
Order-No.	1108058	1108138	1108224	1108375	1108463	1108560	1108659	1108761	1108861
Type	HWR 215 R	HWR 220 R	HWR 225 R	HWR 232 R	HWR 240 R	HWR 250 R	HWR 265 R	HWR 280 R	HWR 2100 R
Order-No.	1108071	1108151	1108171	1108369	1108471	1108571	1108671	1108771	1108871
Type	HWR 215 L	HWR 220 L	HWR 225 L	HWR 232 L	HWR 240 L	HWR 250 L	HWR 265 L	HWR 280 L	HWR 2100 L
Order-No.	1108072	1108152	1108172	1108370	1108472	1108572	1108672	1108772	1108872
Type	HWR 215 K	HWR 220 K	HWR 225 K	HWR 232 K	HWR 240 K	HWR 250 K	HWR 265 K	HWR 280 K	HWR 2100 K
Order-No.	1108073	1108153	1108176	1108376	1108476	1108573	1108673	1108773	1108873

Ø A	13	20	25	32	38	50	66	81	98
B	G 3/8	G 1/2	G 3/4	G 1	G 1 1/4	G 1 1/2	G 2	G 2 1/2	G 3
C	G 1/8	G 1/4	G 3/8	G 1/2	G 3/4	G 1	G 1 1/2	G 1 1/2	G 2
D	G 1/2 A	G 3/4 A	G 1 A	G 1 1/4 A	G 1 1/2 A	G 2 A	G 2 1/2 A	G 3 1/2 A	G 4 A
E	130	146	172	200	223	272	324	393	475
F	109	122	143	167	183	225	264	320	383
G	87	93	104	118	124	146	165	203	243
H	7	8	8	10	11	13	18	18	25
Ø J	80	88	97	114	124	144	182	220	260
Ø K	25	30	35	45	52	66	85	107	118
Ø K G7/h8	24	30	35	45	50	65	85	105	114
L	31	36	40	48	53	62	80	100	115
M	34	42	48	55	65	80	90	115	135
N	47	50	53	62	66	82	93	121	143
O	6	8	8	8	10	10	10	12	12
R	46	50	54	65	70	81	101	121	143
S	12	12	14	16	16	18	20	22	26
T	7	8	9	10	12	13	15	20	22
U	23	23	28	33	36	43	48	54	66
Ø W G7/e8	10	12	16	20	25	31,8	45	45	60
X	15	15	15	15	25	25	30	30	40
Z	117	129	152	170	198	237	284	343	425
SW	22	27	30	41	46	60	75	95	110
Weight (kg)	1,6	2,3	3,2	5,3	6,9	11,1	21,3	37,1	61

H3 DN 25-40

for two way flow of a medium
designed for non-rotating inner pipe, with vacuum breaker

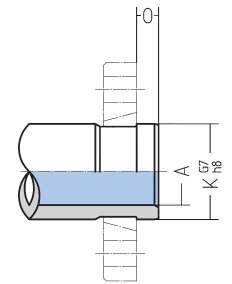
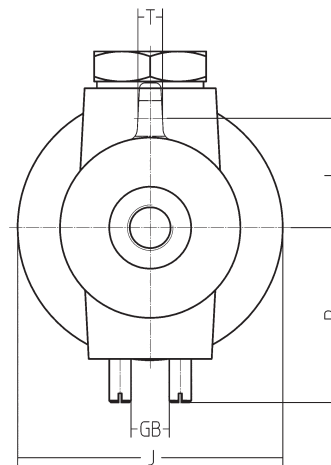
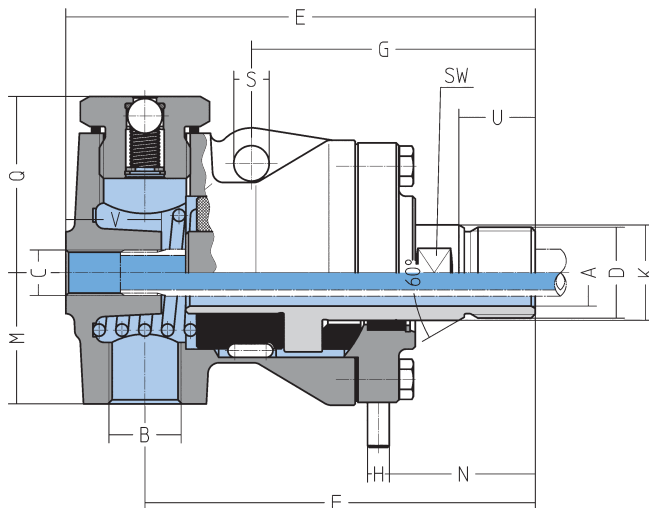

Flanges see page 20

DN	25	32	40
Type	H 325 R	H 332 R	H 340 R
Order-No.	1108216	1108356	1108456
Type	H 325 L	H 332 L	H 340 L
Order-No.	1108217	1108357	1108457
Type	H 325 K	H 332 K	H 340 K
Order-No.	1108218	1108358	1108458

Ø A	25	32	38
B	G 3/4	G 1	G 1 1/4
C	G 3/8	G 1/2	G 3/4
D	G 1 A	G 1 1/4 A	G 1 1/2 A
E	172	200	223
F	143	167	183
G	104	118	124
H	8	10	11
Ø J	97	114	124
Ø K	35	45	52
Ø K G7/h8	35	45	50
L	40	48	53
M	48	55	65
N	53	62	66
O	8	8	10
Q	64	69	74
R	54	65	70
S	14	16	16
T	9	10	12
U	28	33	36
V	35	45	50
SW	30	41	46
Weight (kg)	3,6	5,7	7,3

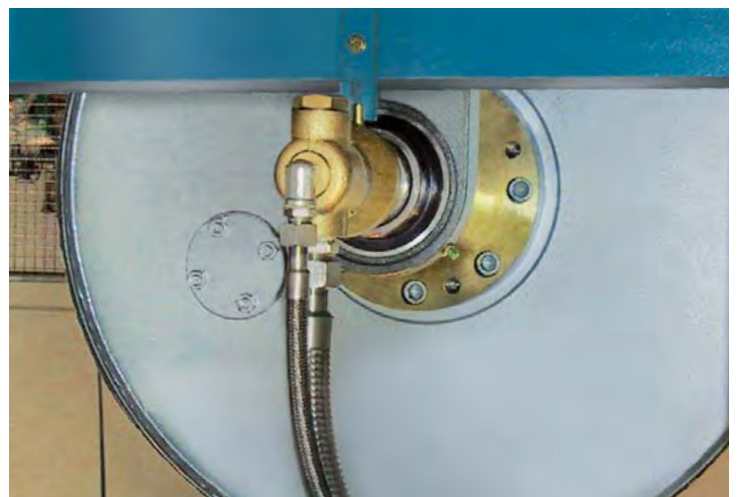

Max 160°C. Higher operating temperatures – please contact us.

HW1 DN 15 - 25 series -450

for one way flow of a medium

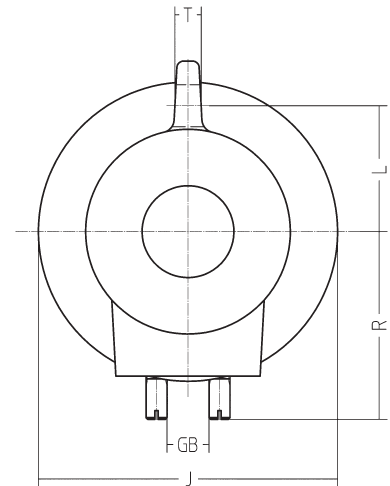
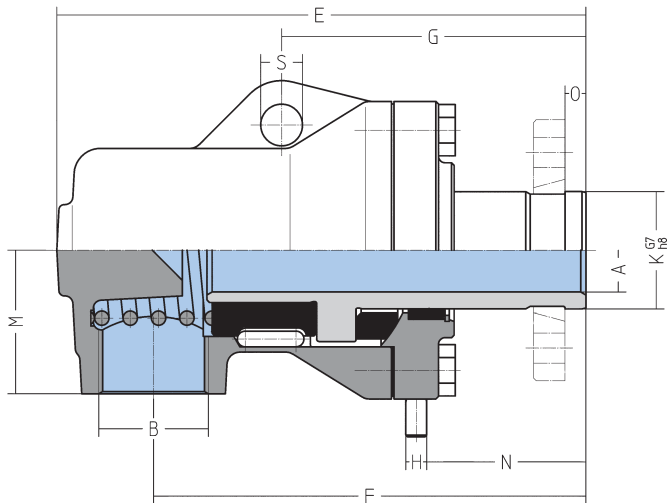

Flanges see page 20

DN	15	20	25
Type	HW 115 K-450	HW 120 K-450	HW 125 K-450
Order-No.	1108067-450	1108147-450	1108169-450

Ø A	13	20	24,5
B	G 1/2	G 3/4	G 1
E	130	146	174
F	107	120	143
G	85	91	104
H	6	6	8
Ø J	80	88	97
Ø K G7/h8	24	30	35
L	31	36	40
M	34	42	48
N	44	49	53
O	6	8	8
R	52	56	64
Ø S	12	12	12
T	7	8	9
GB	12	12	14
Weight (kg)	1,7	2,4	3,4

HW2 + HWR2 DN 20 + 25 series -450

for two way flow of a medium

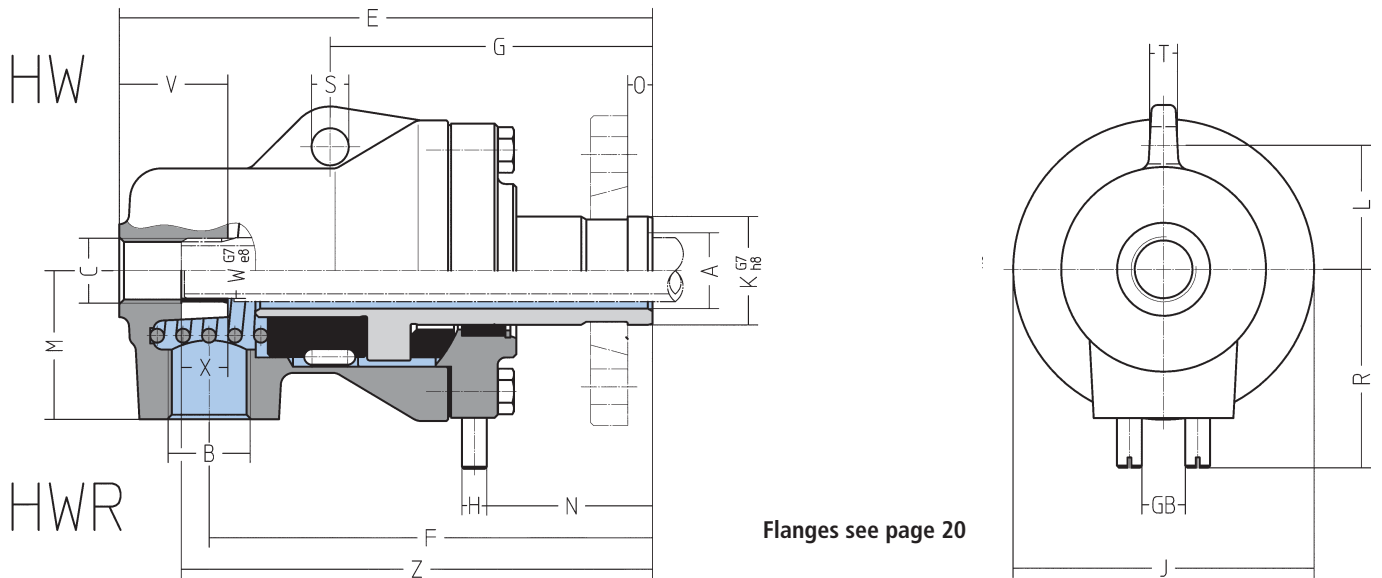

DN	20	25
Type	HW 220 K-450	HW 225 K-450
Order-No.	1108150-450	1108170-450
Type	HWR 220 K-450	HWR 225 K-450
Order-No.	1108153-450	1108176-450

Ø A	20	24,5
B	G 1/2	G 3/4
C	G 3/8	G 1/2
E	144	172
F	120	143
G	91	104
H	6	8
Ø J	88	97
Ø K G7/h8	30	35
L	36	40
M	42	48
N	49	53
O	8	8
R	56	64
Ø S	12	12
T	8	9
V	32	35
Ø W G7/e8	16	18
X	15	15
Z	127	152
GB	12	14
Weight (kg)	2,3	3,2

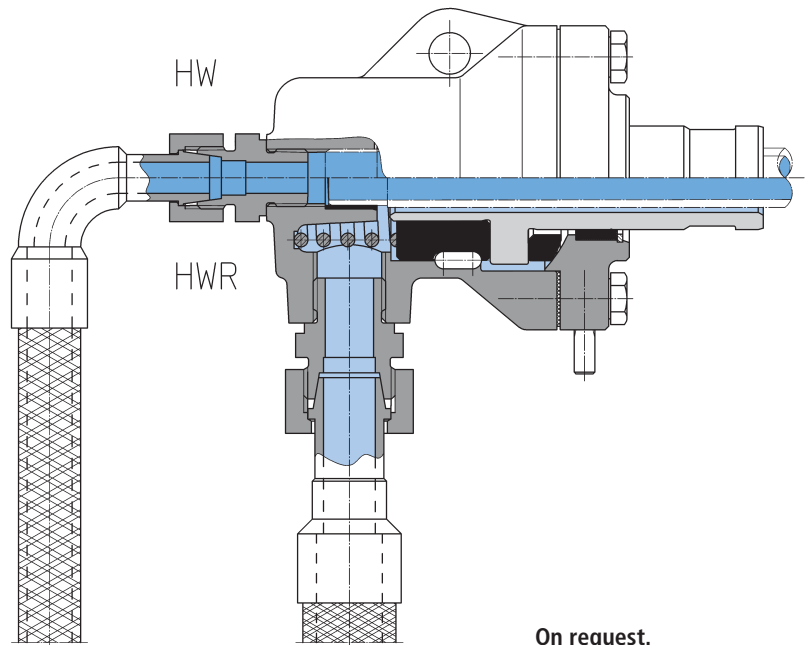

On request.

HW1 DN 32-100 series -500

for one way flow of a medium

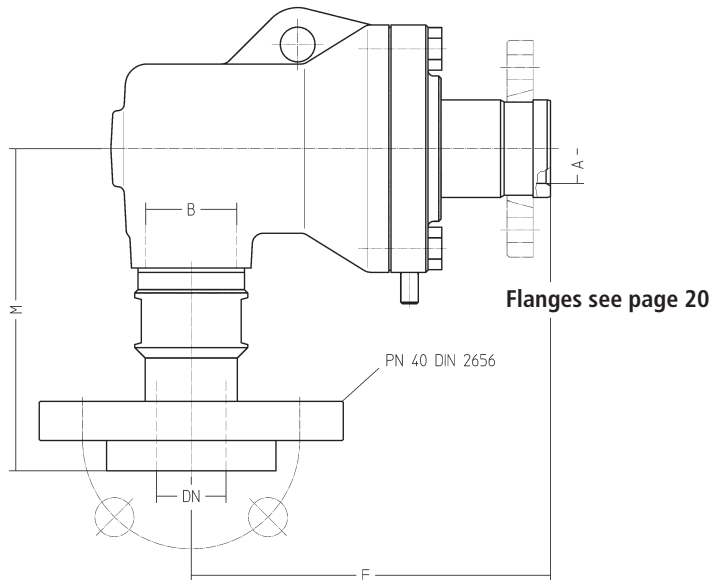

DN	32	40	50	65	80	100
Type	HW 132 K-500	HW 140 K-500	HW 150 K-500	HW 165 K-500	HW 180 K-500	HW 1100 K-500
Order-No.	1108368-500	1108467-500	1108567-500	1108667-500	1108767-500	1108867-500
Ø A	32	38	50	66	81	98
B	G 1 1/4	G 1 1/2	G 2	G 2 1/2	G 3	G 4
F	167	183	225	264	320	383
M	148,5	160,5	179	193	239,5	277
DN	32	40	50	65	80	100
Weight (kg)	8,5	10,5	16	27	46	74

All other dimensions see page 6.

Special designs of series H rotary joints for continuous casting machines

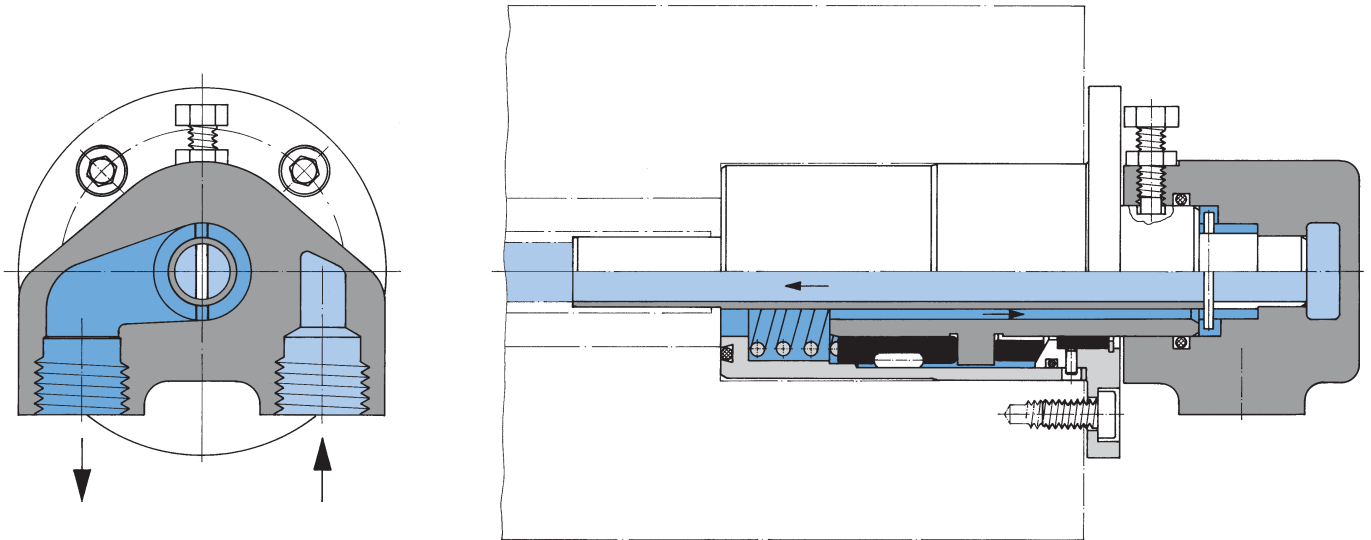

HW 225 K-74: integrated in roller trunnion with distributor for flow and return.

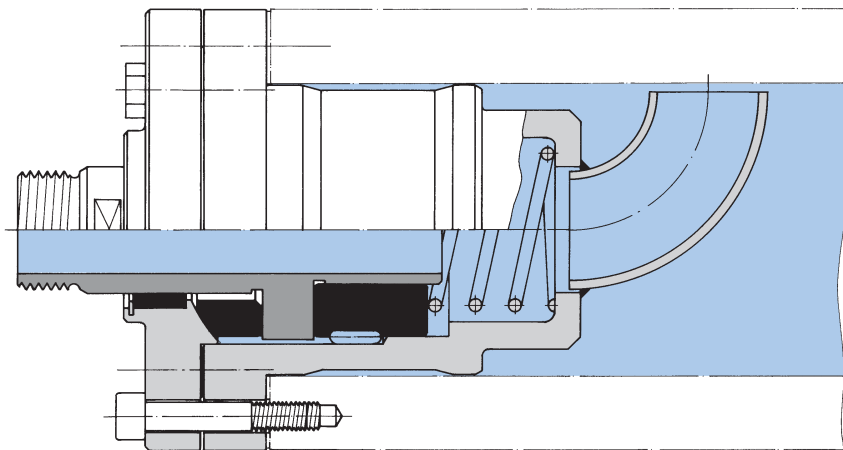

HW 125 K-24: integrated in roller trunnion at return for cooling water.

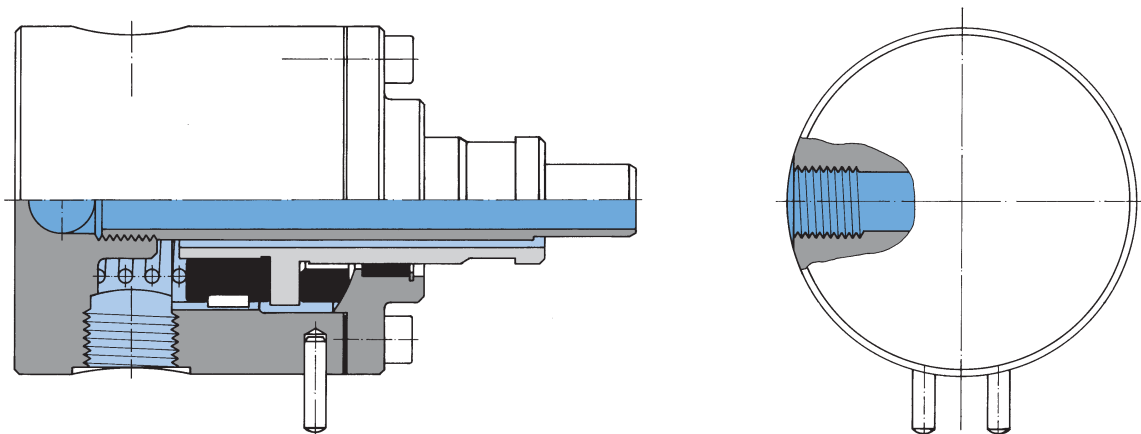

HW 225 K-27: Compact rotary joint with double connection.

HWX2 DN 32-100

for two way flow of a medium
designed for non-rotating inner pipe

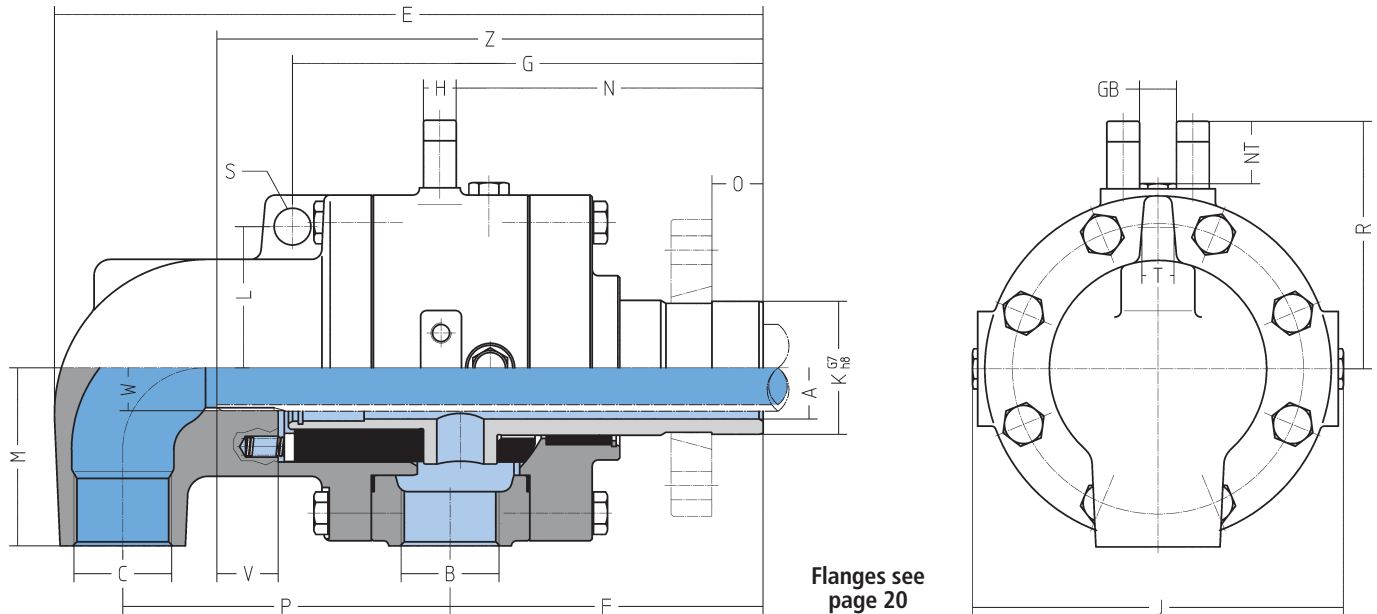

DN	32	40	50	65	75	80	100
Type	HWX 232 K	HWX 240 K	HWX 250 K	HWX 265 K	HWX 275 K	HWX 280 K	HWX 2100 K
Order-No.	1108385	1108485	1108585	1108685	1108705	1108785	1108885
Ø A	32	38	50	66	67	80	98
B	G 1	G 1 1/4	G 1 1/2	G 2	G 2 1/2	G 2 1/2	G 3
C	G 1	G 1 1/4	G 1 1/2	G 2	G 2 1/2	G 2 1/2	G 3
E	271	313	347	402	535	540	609
F	120	132	153	178	270	275	305
G	183	204,5	230	272	380	385	424
H	13,5	16	16	18	18	18	25
J	150	159	181	218	274	274	302
Ø K G7 / h8	45	50	65	85	87,29	105	114
L	55	58	69	85	106	106	120
M	70	75	87	103	130	130	145
N	118	129	150	179	267	272	299
O	15	20	25	25	22,2	30	30
P	125	151	160	180	210	210	240
R	98	110	121	144	172	172	194
Ø S	16	16	18	20	22	22	26
T	13	15	16	18	25	25	26
V	25	30	30	30	25	30	30
W	G 3/4	G 1	G 1 1/4	G 1 1/2	G 1 1/2	G 2	G 2 1/2
Z	206	230	267	307	416	426	472
GB	16	16	18	20	22	22	26
NT	23	30,5	30,5	35	35	35	43
Weight (kg)	12	16,5	22	37	73	73	92

HWB2 DN 32-100

for two flow of a medium
designed for rotating inner pipe

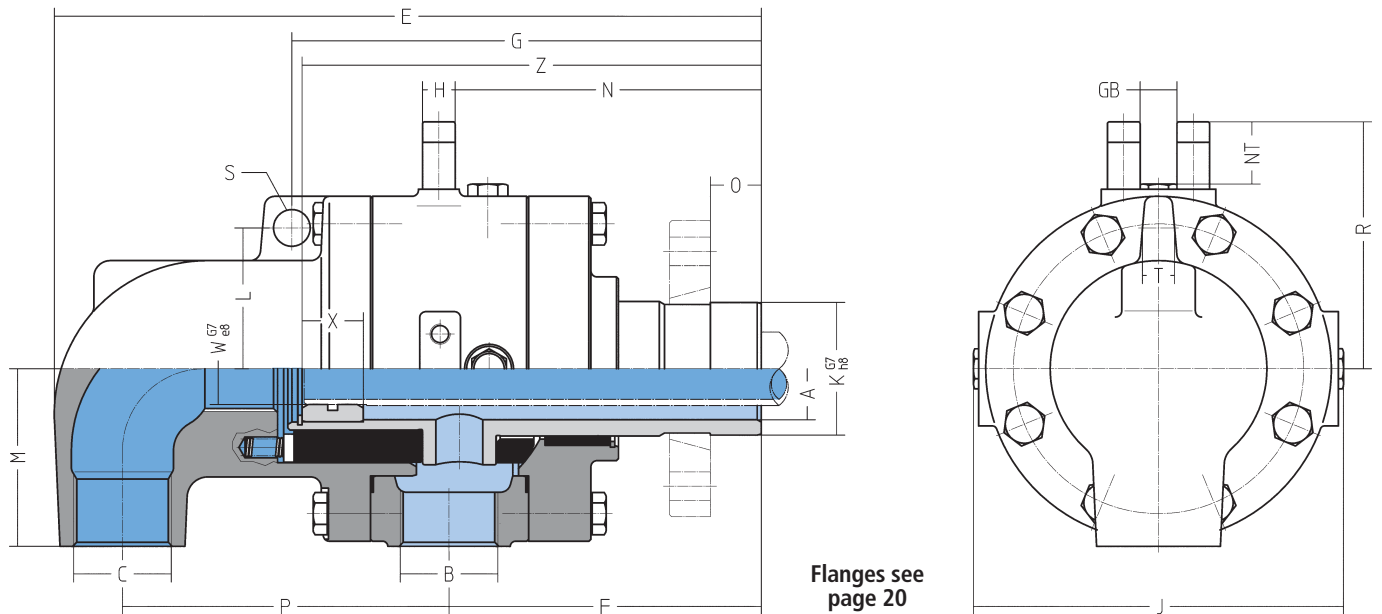

DN	32	40	50	65	75	80	100
Type	HWB 232 K	HWB 240 K	HWB 250 K	HWB 265 K	HWB 275 K	HWB 280 K	HWB 2100 K
Order-No.	1108402	1108482	1108577	1108677	1108702	1108778	1108902
Ø A	32	38	50	66	67	80	98
B	G 1	G 1 1/4	G 1 1/2	G 2	G 2 1/2	G 2 1/2	G 3
C	G 1	G 1 1/4	G 1 1/2	G 2	G 2 1/2	G 2 1/2	G 3
E	271	313	347	402	535	540	609
F	120	132	153	178	270	275	305
G	183	204,5	230	272	380	385	424
H	13,5	16	16	18	18	18	25
J	150	159	181	218	274	274	302
Ø K G7/h8	45	50	65	85	87,29	105	114
L	55	58	69	85	106	106	120
M	70	75	87	103	130	130	145
N	118	129	150	179	267	272	299
O	15	20	25	25	22,2	30	30
P	125	151	160	180	210	210	240
R	98	110	121	144	172	172	194
Ø S	16	16	18	20	22	22	26
T	13	15	16	18	25	25	26
Ø W G7/e8	22	28	35	45	45	60	75
X	30	30	30	40	40	40	50
Z	172	190	225	260	372	377	419
GB	16	16	18	20	22	22	26
NT	23	30,5	30,5	35	35	35	43
Weight (kg)	12	16,5	22	37	73	73	92

HWA2 DN 32-100

for two flow of a medium
designed for rotating inner pipe

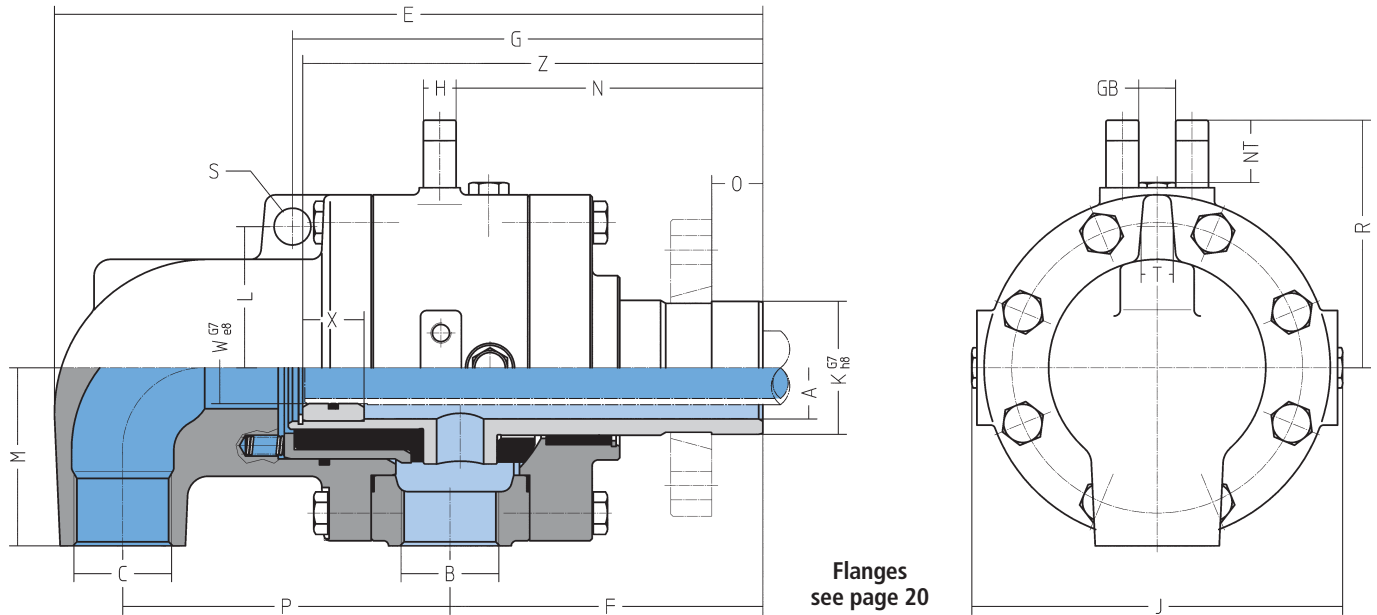

DN	32	40	50	65	75	80	100
Type	HWA 232 K	HWA 240 K	HWA 250 K	HWA 265 K	HWA 275 K	HWA 280 K	HWA 2099 K
Order-No.	1108390	1108490	1108590	1108690	1108710	1108790	1108880
Ø A	32	38	50	66	67	80	98
B	G 1	G 1 1/4	G 1 1/2	G 2	G 2 1/2	G 2 1/2	G 3
C	G 1	G 1 1/4	G 1 1/2	G 2	G 2 1/2	G 2 1/2	G 3
E	271	313	347	402	535	540	609
F	120	132	153	178	270	275	305
G	183	204,5	230	272	380	385	424
H	13,5	16	16	18	18	18	25
J	150	159	181	218	274	274	302
Ø K G7/h8	45	50	65	85	87,29	105	114
L	55	58	69	85	106	106	120
M	70	75	87	103	130	130	145
N	118	129	150	179	267	272	299
O	15	20	25	25	22,2	30	30
P	125	151	160	180	210	210	240
R	98	110	121	144	172	172	194
Ø S	16	16	18	20	22	22	26
T	13	15	16	18	25	25	26
Ø W G7/e8	22	28	35	45	45	60	75
X	30	30	30	40	40	40	50
Z	172	190	225	260	372	377	419
GB	16	16	18	20	22	22	26
NT	23	30,5	30,5	35	35	35	43
Weight (kg)	12	16,5	22	37	73	73	92

HWX2 + HWB2 + HWA2 DN 32-100 series -500

with flange connections

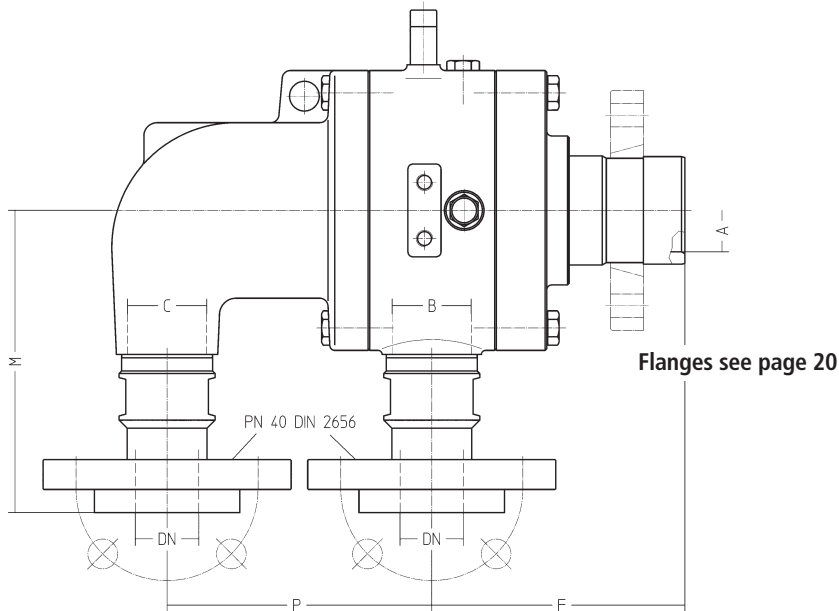

DN	32	40	50	65	75	80	100
Type	HWX 232 K-500	HWX 240 K-500	HWX 250 K-500	HWX 265 K-500	HWX 275 K-500	HWX 280 K-500	HWX 2100 K-500
Order-No.	1108385-500	1108485-500	1108585-500	1108685-500	1108705-500	1108785-500	1108885-500
Type	HWB 232 K-500	HWB 240 K-500	HWB 250 K-500	HWB 265 K-500	HWB 275 K-500	HWB 280 K-500	HWB 2100 K-500
Order-No.	1108402-500	1108482-500	1108577-500	1108677-500	1108702-500	1108778-500	1108902-500
Type	HWA 232 K-500	HWA 240 K-500	HWA 250 K-500	HWA 265 K-500	HWA 275 K-500	HWA 280 K-500	HWA 2099 K-500
Order-No.	1108390-500	1108490-500	1108590-500	1108690-500	1108710-500	1108790-500	1108880-500

Ø A	32	38	50	66	67	80	98
B	G 1	G 1 1/4	G 1 1/2	G 2	G 2 1/2	G 2 1/2	G 3
C	G 1	G 1 1/4	G 1 1/2	G 2	G 2 1/2	G 2 1/2	G 3
F	120	132	153	178	270	275	305
M	161,5	168,5	182,5	202	233	233	269,5
P	125	151	160	180	210	210	240
DN	25	32	40	50	65	65	80
Weight (kg)	16	22	29	46,5	84,5	84,5	107

All other dimensions see pages 14, 15 und 16.

HW1 DN 125-300

for one way flow of a medium

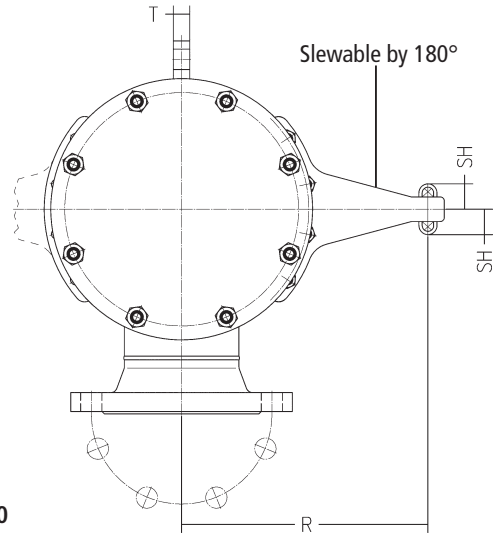
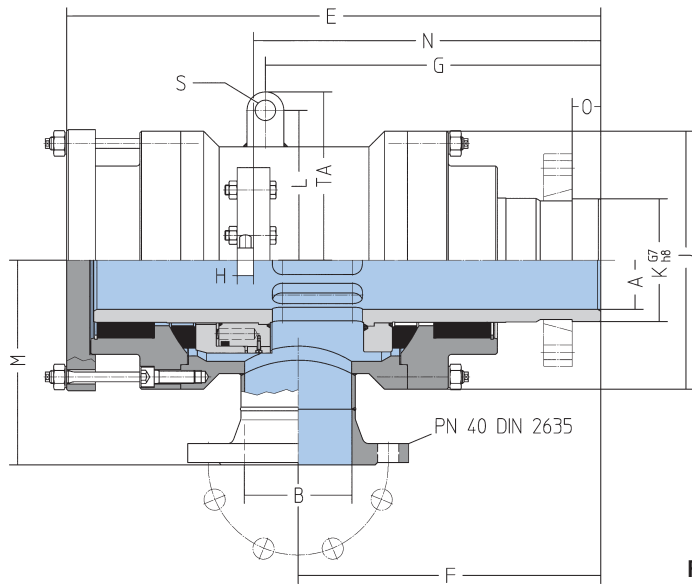

Flanges see page 20

DN	125	150	200	300
Type	HW 1125 K	HW 1150 K	HW 1200 K	HW 1300 K
Order-No.	1104001	1104101	1104201	1104401
Ø A	120	145	195	298
B	DN 125	DN 150	DN 200	DN 300
E	653	706	881	1314
F	370	393	498	700
G	410	440	560	840
H	20	25	25	35
Ø J	319	346	420	595
Ø K G7/h8	150	180	230	350
L	183	210	265	385
M	250	258	320	486
N	410	413	593	853
O	35	40	45	60
R	300	350	400	700
Ø S	25	40	40	50
T	20	25	25	40
SH	31	46	46	58
TA	206	245	305	435

Weight (kg)

HWA2 DN 100-300

for two flow of a medium
designed for rotating inner pipe

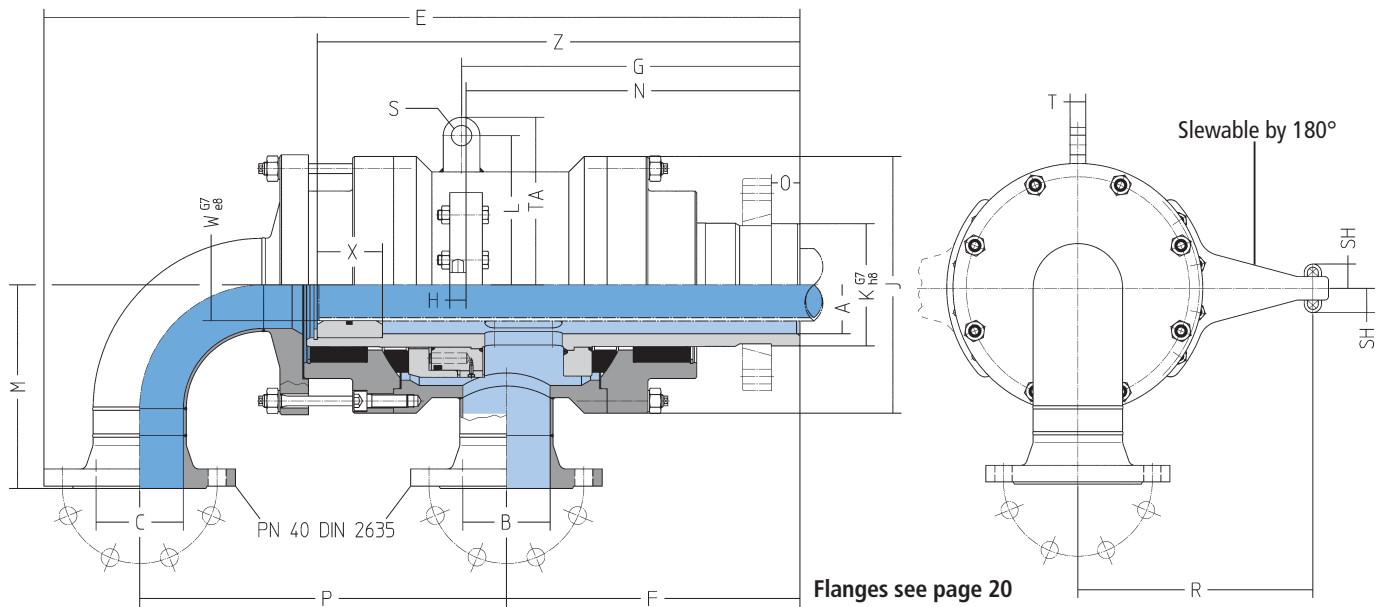

DN	100	125	150	200	300
Type	HWA 2100 K	HWA 2125 K	HWA 2150 K	HWA 2200 K	HWA 2300 K
Order-No.	1108890	1104002	1104102	1104202	1104402
Ø A	98	120	145	195	298
B	DN 80	DN 100	DN 125	DN 150	DN 250
C	DN 80	DN 100	DN 125	DN 150	DN 250
E	815	928	1030	1286	1910
F	328	360	394	498	708
G	365	415	445	570	840
H	20	20	25	25	35
Ø J	268	319	346	420	595
Ø K G7/h8	114	150	180	230	350
L	152	183	210	265	385
M	210	250	258	304	486
N	360	410	413	593	853
O	30	35	40	45	60
P	388	450	502	638	977
R	250	300	350	400	700
Ø S	25	25	40	40	50
T	20	20	25	25	40
Ø W G7/e8	75	88	110	135	215
X	80	80	80	100	150
Z	528	592	635	808	1169
SH	31	31	46	46	58
TA	117	206	245	305	435
Weight (kg)					

Journal Flanges for K Rotor Connection

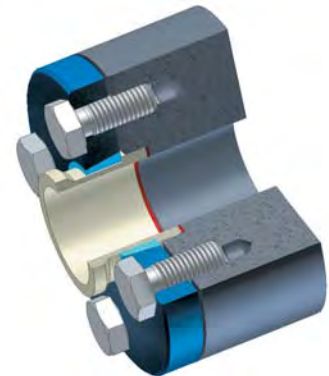
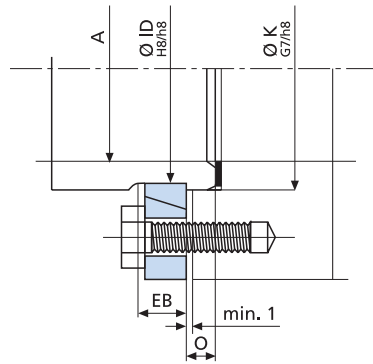
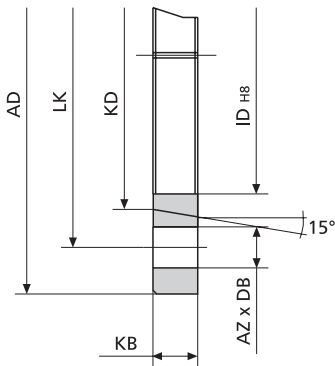

DN	K flange	Order No.	Inner ring	Order No.	Flat pack. Order No.	Ø A	Ø AD	Ø LK	AZ x Ø DB	Ø KD	Ø ID H8/h8	KB	Ø K G7/h8	O	EB
10	KF 10-0	1190430	IR 10-0	1190400	3512230	10	55	40	4x7	20	17	10	18	6	11
15	KF 15-0	1190431	IR 15-0	1190401	3512231	13	70	50	4x9	26	22	10	24	6	11
20	KF 20-0	1190432	IR 20-0	1190402	3512232	20	75	55	4x9	32	28	12	30	8	13
25	KF 25-0	1190433	IR 25-0	1190403	3512233	25	80	60	4x9	37	33	12	35	8	13
32	KF 32-0	1190434	IR 32-0	1190404	3512234	32	100	75	4x11	48	43	12	45	8	13
32	KF 32-500	1190434-500	IR 32-500	1190404-500	3512234	32	115	90	4x11	48	43	15	45	15	16
40	KF 40-0	1190435	IR 40-0	1190405	3512235	38	105	80	4x11	53	48	15	50	10	16
40	KF 40-500	1190435-500	IR 40-500	1190405-500	3512235	38	120	95	4x11	53	48	18	50	20	20
50	KF 50-0	1190436	IR 50-0	1190406	3512236	50	130	100	4x14	69	63	15	65	10	16
50	KF 50-500	1190436-500	IR 50-500	1190406-500	3512236	50	145	115	4x14	69	63	20	65	25	22
65	KF 65-0	1190437	IR 65-0	1190407	3512237	66	150	120	4x14	89	82	15	85	10	16
65	KF 65-500	1190437-500	IR 65-500	1190407-500	3512237	66	165	135	4x14	89	82	25	85	25	28
65	KF 65-37	1190437-037	IR 65-0	1190407	3512237	66	150	120	6x14	89	82	15	85	25	28
80	KF 80-0	1190438	IR 80-0	1190408	3512238	81	180	145	4x18	109	102	18	105	12	20
80	KF 80-500	1190438-500	IR 80-500	1190408-500	3512238	81	205	170	4x18	109	102	30	105	30	34
100	KF 100-0	1190439	IR 100-0	1190409	3512239	98	195	160	6x18	120	110	20	114	12	22
100	KF 100-500	1190439-500	IR 100-500	1190409-500	3512239	98	220	185	6x18	120	110	30	114	30	34
125	KF 125-0	1190450	IR 125-0	1190410	1190025	120	225	190	6x18	147	137	22	142	20	25
125	KF 125-500	1190450-500	IR 125-500	1190410-500	1190035	120	260	225	8x18	155	145	35	150	35	39
150	KF 150-0	1190451	IR 150-0	1190411	1190026	145	255	220	8x18	178	165	25	170	25	28
150	KF 150-500	1190451-500	IR 150-500	1190411-500	1190036	145	300	260	8x18	185	175	40	180	40	44
200	KF 200-0	1190452	IR 200-0	1190412	1190027	195	310	275	8x18	232	220	28	225	30	32
200	KF 200-500	1190452-500	IR 200-500	1190412-500	1190037	195	360	320	8x18	235	224	45	230	45	49
250	KF 250-0	1190453	IR 250-0	1190413	1190028	240	390	350	8x23	290	273	37	280	35	40
250	KF 250-500	1190453-500	IR 250-500	1190413-500	1190038	240	435	390	8x23	295	278	50	285	50	54
300	KF 300-0	1190454	IR 300-0	1190414	1190029	295	470	410	16x23	350	332	42	340	40	45

Versions KF...-0 and IR...-0:

DX/DXS	DN 10 – 80
DXSB	DN 50 – 80
DP	DN 40 – 50
H/HW	DN 15 – 100
HWB/A) ¹	DN 32 – 100
M	DN 15 – 100
DA	DN 50 – 300

Versions KF...-500 and IR...-500:

DXSB	DN 100 – 150
HWA	DN 100 – 300
DQ	DN 25 – 150

It is important to evenly tighten the screws.

)¹ KF65-0 only up to 210°C, 20 bar or 300°C, 10 bar.
For higher data use KF 65-37.

Loose Flanges for Housing Connection

Sealing with sealing rings

The flanges consist of a threaded piece with male thread ISO 228, welded to a welded neck with loose flange DIN 2656 (PN 40).

Sealing between flange and rotary joint housing by means of a copper sealing ring.

Suitable for HWA, HWB and HWX.

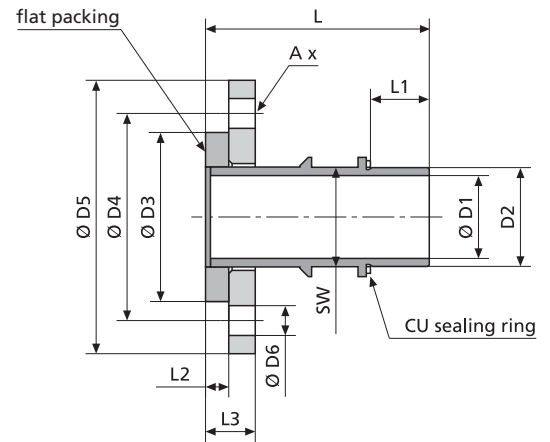
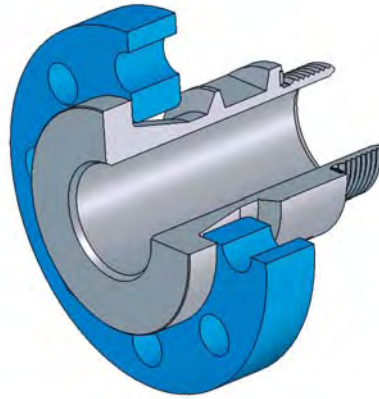

Dimension table for screw-in flanges rated pressure PN 40

DN	L	L1	L2	L3	D1	D2	D3	D4	D5	A	D6	SW	Order No. Screw-in flange	Order No. CU sealing ring / flat packing	Order No. Flat packing
25	112	20,5	14	32	23,3	G 1 A	68	85	115	4	14	36	1190203-101	3502111-001	3512266
32	116	22,5	14	32	32	G 1 1/4 A	78	100	140	4	18	46	1190204-101	3502117-001	3512267
40	120	24,5	14	32	38,3	G 1 1/2 A	88	110	150	4	18	50	1190205-101	3502118-001	3512268
50	128	29,0	16	36	50	G 2 A	102	125	165	4	18	60	1190206-101	3502121-010	3512269
65	135	32,0	16	36	64	G 2 1/2 A	122	145	185	8	18	75	1190207-101	3502124-010	3512270
80	158	33,5	18	40	77	G 3 A	138	160	200	8	18	90	1190208-101	3502125-010	3512271
100	180	38	20	42	98	G 4 A	162	190	235	8	22	110	1190209-101	3502108-010	3512272

Maximum application data (pressure reduction factor at higher operating temperatures considered):

- water 28 bar and 230°C
- thermal oil 10 bar and 300°C

Please order a flat packing for the connection flange, if required.

Material: steel, lacquered.
Special stainless steel version available upon request.

Spare parts for types H / HW – DN 15-100

Spare parts H1 + HW1, H2 + HW2, HR2 + HWR2, H3

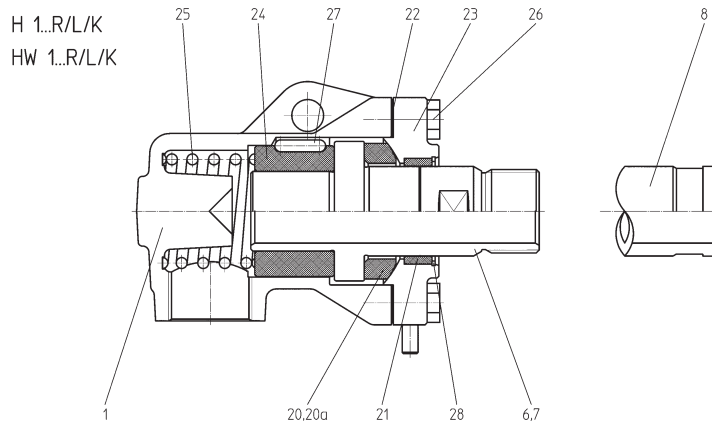

H 2...R/L/K
HW 2...R/L/K

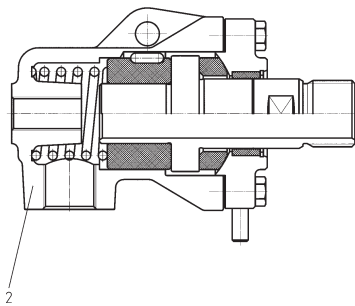

HR 2...R/L/K
HWR 2...R/L/K

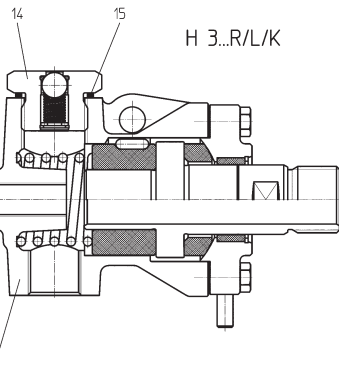
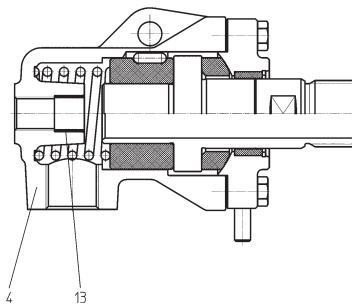

DN	15	20	25	32	40	50	65	80	100
1 Housing 1	1103059	1103139	1103222	1103362	1103462	1103559	1103633	1103762	1103862
2 Housing 2	1103060	1103140	1103223	1103363	1103463	1103560	1103634	1103763	1103863
3 Housing 3	-	-	1103224	1103364	1103464	-	-	-	-
4 Housing R2	1103061	1103141	1103225	1103365	1103465	1103561	1103649	1103765	1103865
6 Rotor R	1103063	1103143	1103227	1103367	1103467	1103563	1103643	1103767	1103867
7 Rotor L	1103064	1103144	1103228	1103368	1103468	1103564	1103644	1103768	1103868
8 Rotor K	1103065	1103145	1103229	1103369	1103469	1103565	1103637	1103769	1103869
13 Slide bearing x	3510502	3510504	3510506	3510501	3510509	3510512	3510514	3510514	3510523
14 Vacuum valve	-	-	1190020	1190020	1190020	-	-	-	-
15 CU seal	-	-	3511962	3511962	3511962	-	-	-	-
20 Sealing ring	3511301	3511302	3511303	3511304	3511305	3511306	3511307	3511308	3511309
20a Sealing ring W	3510641	3510642	3510643	3510644	3510645	3510646	3510647	3510648	3510649
21 Cover bearing	3510601	3510602	3510603	3510604	3510605	3510606	3510607	3510608	3510609
22 Flat packing	3512001	3512002	3512003	3512004	3512005	3512006	3512007	3512016	3512017
23 Cover compl.	1108059	1108139	1108221	1108361	1108461	1108559	1108653	1108759	1108858
24 Carbon bearing	3511341	3511342	3511343	3511344	3511345	3511346	3511347	3511348	3511349
25 Compression spring	3511616	3511617	3511618	3511619	3511620	3511621	3511622	3511626	3511627
26 Hexagon screw	3500087	3500087	3500087	3500125	3500125	3500165	3500163	3500163	3500197
27 Locking pin	3500932	3500932	3500932	3500933	3500933	3500934	3500934	3500934	3500934
28 Circlip	3500701	3500697	3500702	3500703	3500704	3500705	3500706	3500707	3500708

Please specify exact type designation when inquiring or ordering!

Spare parts for types HWX2 / HWB2 / HWA2 – DN 32-100

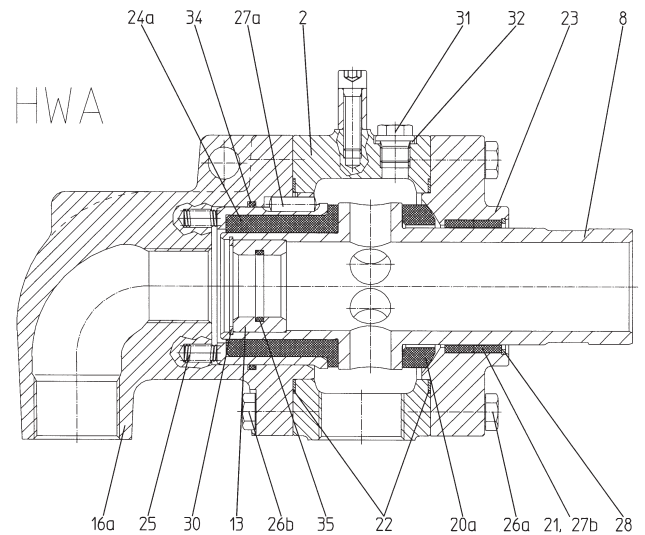
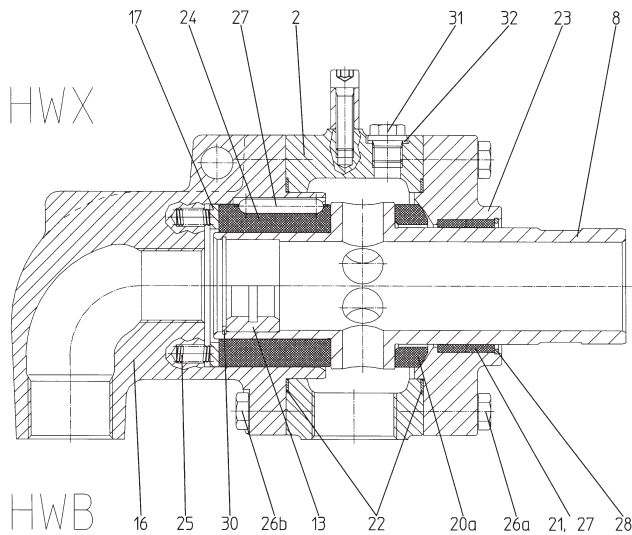

DN	32	40	50	65	75	80	100
2 Housing	1103400	1103500	1103582	1103700	1103810	1103810	1103930
8 Rotor	1103404	1103504	1103587	1103704	1103752	1103814	1103934
13 Bushing	1103387-417	1103481-365	1103581-428	1103651-397	1103755-054	1103787-446	1103888-552
16 Elbow B2, X2	1103409	1103509	1103594	1103709	1103757	1103819	1103939
16a Elbow A2	1103410	1103510	1103595	1103710	1103758	1103820	1103940
17 Thrust washer	1103392-432	1103492-377	1103613-441	1103746-419	1103792-463	1103792-463	1103921-570
20a Sealing ring W	3510644	3510645	3510646	3510647	3510648	3510648	3510649
21 Cover bushing	3510604	3510605	3510606	3510607	3511348	3511348	3511349
22 Gasket	1114193-059	1103799-419	3512013	3512018	1110669-063	1110669-063	3512355-071
23 Cover compl.	1103407	1103507	1103592	1103707	1103817	1103817	1103937
24 Carbon bushing B2, X2	3511344	3511345	3511346	3511347	3511348	3511348	3511349
24a Carbon bushing A2	3511344-421	3511345-362	3511346-426	3511347-398	3511348-449	3511348-449	3511349-549
25 Compression spring	5x 3511668-001	6x 3511668-001	8x 3511668-001	4x 3511564	8x 3511564	8x 3511564	12x 3511564
26a Hexagon screw 1	8x 3500123-008	8x 3500124-008	8x 3500166-008	8x 3500163	8x 3500197	8x 3500197	8x 3500197
26b Hexagon screw 2	8x 3500125	8x 3500123-008	8x 3500165	8x 3500163	8x 3500197	8x 3500197	8x 3500197
27 Locking pin B2, X2	1x 3500933	1x 3500933	1x 3500934	1x 3500934	2x 3500934	2x 3500934	2x 3500934
27a Locking pin 1 A2	3500951-001	3500933	3500889-001	3500961-001	3500961-001	3500961-001	3500934
27b Locking pin 2 A2	–	–	–	–	3500934	3500934	3500934
28 Circlip	3500703	3500704	3500705	3500706	3501237-001	3501237-001	3501043
30 Circlip	3501234	3501225	3501232	3501236	3501205	3501205	3501251
31 Screw plug	3x 3500657	3x 3500658-007	3x3500658-007	3x 3500655-007	3x 3500655-007	3x 3500655-007	3x 3500655-007
32 Sealing ring	3x 3502114-001	3x 3502116-001	3x 3502116-001	3x3502115-001	3x 3502115-001	3x 3502115-001	3x 3502115-001
34 O-ring	3511701	3511708	3511694	3511692	3511702	3511702	3512515
35 O-ring	3511955	3511824	3511733	3511931	3511734	3511816	3511825

Please specify exact type designation when inquiring or ordering!

Spare parts for type HW1 – DN 125-300

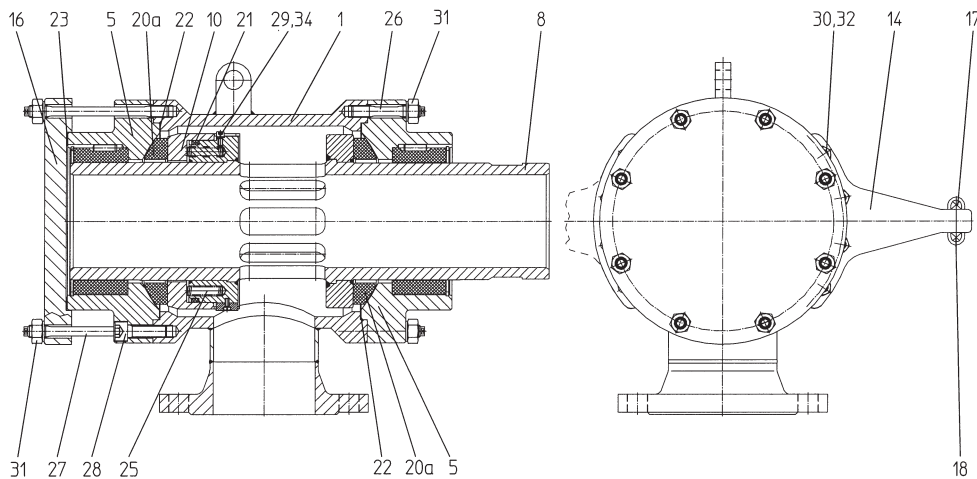

DN	125	150	200	300
1 Housing 1	1104025-240	1104125-210	1104225-164	1104425-132
5 Cover compl. (2x)	1104030-200	1104130-184	1104230-129	1104430-040
8 Rotor K compl.	1104054-242	1104154-212	1104254-166	1104454-134
10 Butting ring	1104061-221	1104161-199	1104261-156	1104461-116
14 Anti-rotation device	1104074-231	1104174-209	1104274-163	1104447-137
16 Cover 1	1104045-244	1104145-214	1104245-168	1104445-136
17 Contact bolt 1	1103899-578	1104124-205	1104124-205	1104424-104
18 Contact bolt 2	1103899-579	1104124-206	1104124-206	1104424-106
20a Sealing ring W	3511353	3511354	3511355	3511357
21 O-ring	3512512-015	3512517-015	3511751-015	3512518-015
22 Gasket	1104075-185	1104175-178	1104275-105	3512022
23 Gasket	1190037	1104075-185	1105695-050	3512023-063
25 Compression spring	16x 3511564	18x 3511564	26x 3511532	28x 3511457
26 Screw 1	8x 3500236	8x 3500236	16x 3500200-008	16x 3500248-002
27 Screw 2	8x 3500244-007	8x 3500432-007	16x 3500435-007	16x 3500436-007
28 Cyl. head screw	2x 3500410	2x 3500195	2x 3500410	2x 3500444
29 Cyl. head screw	2x 3500329-003	2x 3500433-003	2x 3500376-003	2x 3500376-003
30 Hexagon Screw	4x 3500162-008	4x 3500434-008	4x 3500434-008	4x 3500248-002
31 Hexagon nut	16x 3500300	16x 3500300	16x 3500300	16x 3500304
32 Hexagon nut	4x 3500285-008	4x 3500287-008	4x 3500287-008	4x 3500304
34 Spring washer	2x 3500723	2x 3500717	2x 3500718	2x 3500718

Please specify exact type designation when inquiring or ordering!

Spare parts for type HWA2 – DN 100-300

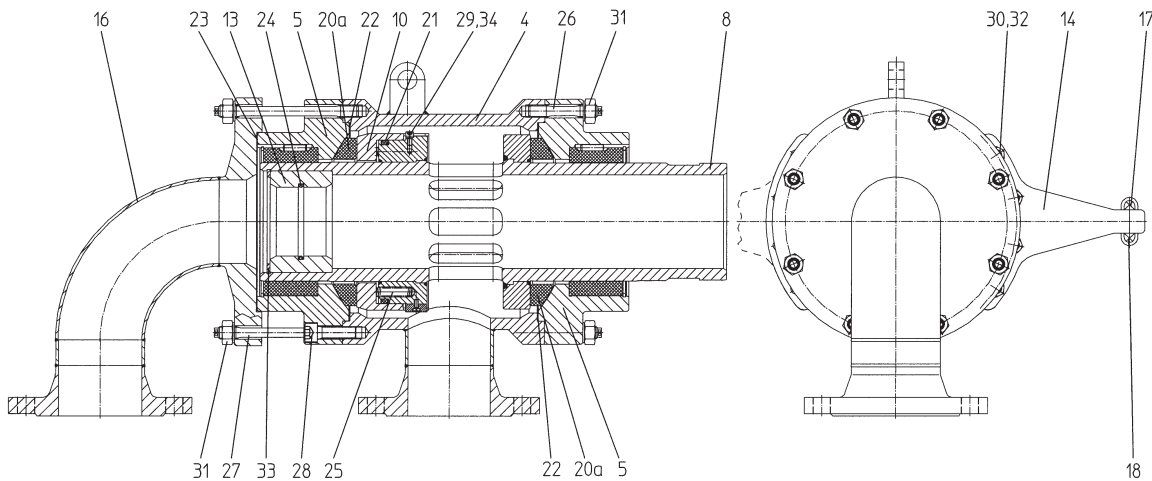

DN	100	125	150	200	300
4 Housing 2	1103877-532	1104025-245	1104125-201	1104225-159	1104425-110
5 Cover compl. (2x)	1103879-541	1104030-200	1104130-184	1104230-129	1104430-040
8 Rotor K compl.	1103884-534	1104055-217	1104155-175	1104255-155	1104455-112
10 Butting ring	1103896-539	1104061-221	1104161-199	1104261-156	1104461-116
13 Rotor bushing	1103888-540	1104059-214	1104129-208	1104248-157	1104446-117
14 Anti-rotation device	1103924-542	1104074-231	1104174-209	1104274-163	1104447-137
16 Elbow A2	1103906-536	1104051-224	1104151-197	1104251-160	1104451-108
17 Contact bolt 1	1103899-578	1103899-578	1104124-205	1104124-205	1104424-104
18 Contact bolt 2	1103899-579	1103899-579	1104124-206	1104124-206	1104424-106
20a Sealing ring W	3510649	3511353	3511354	3511355	3511357
21 O-ring	3511703-015	3512512-015	3512517-015	3511751-015	3512518-015
22 Gasket	1103909-335	1104075-185	1104175-178	1104275-105	3512022
23 Gasket	1110518-113	1190037	1104075-185	1105695-050	3512023-063
24 O-ring	3511855	3511826	3511692	3511873	3512519
25 Compression spring	12x 3511564	16x 3511564	18x 3511564	26x 3511532	28x 3511457
26 Screw 1	16x 3500196-007	8x 3500236	8x 3500236	16x 3500200-008	16x 3500248-002
27 Screw 2	16x 3500209-007	8x 3500244-007	8x 3500432-007	16x 3500435-007	16x 3500436-007
28 Cyl. head screw	2x 3500428	2x 3500410	2x 3500195	2x 3500410	2x 3500444
29 Cyl. head screw	2x 3500329-003	2x 3500329-003	2x 3500433-003	2x 3500376-003	2x 3500376-003
30 Hexagon screw	4x 3500162-008	4x 3500162-008	4x 3500434-008	4x 3500434-008	4x 3500248-002
31 Hexagon nut	–	16x 3500300	16x 3500300	16x 3500300	16x 3500304
32 Hexagon nut	4x 3500285-008	4x 3500285-008	4x 3500287-008	4x 3500287-008	4x 3500304
33 Circlip	3501251	3501252-001	3501237-001	3501231	3501264
34 Spring washer	2x 3500723	2x 3500723	2x 3500717	2x 3500718	2x 3500718

Please specify exact type designation when inquiring or ordering!

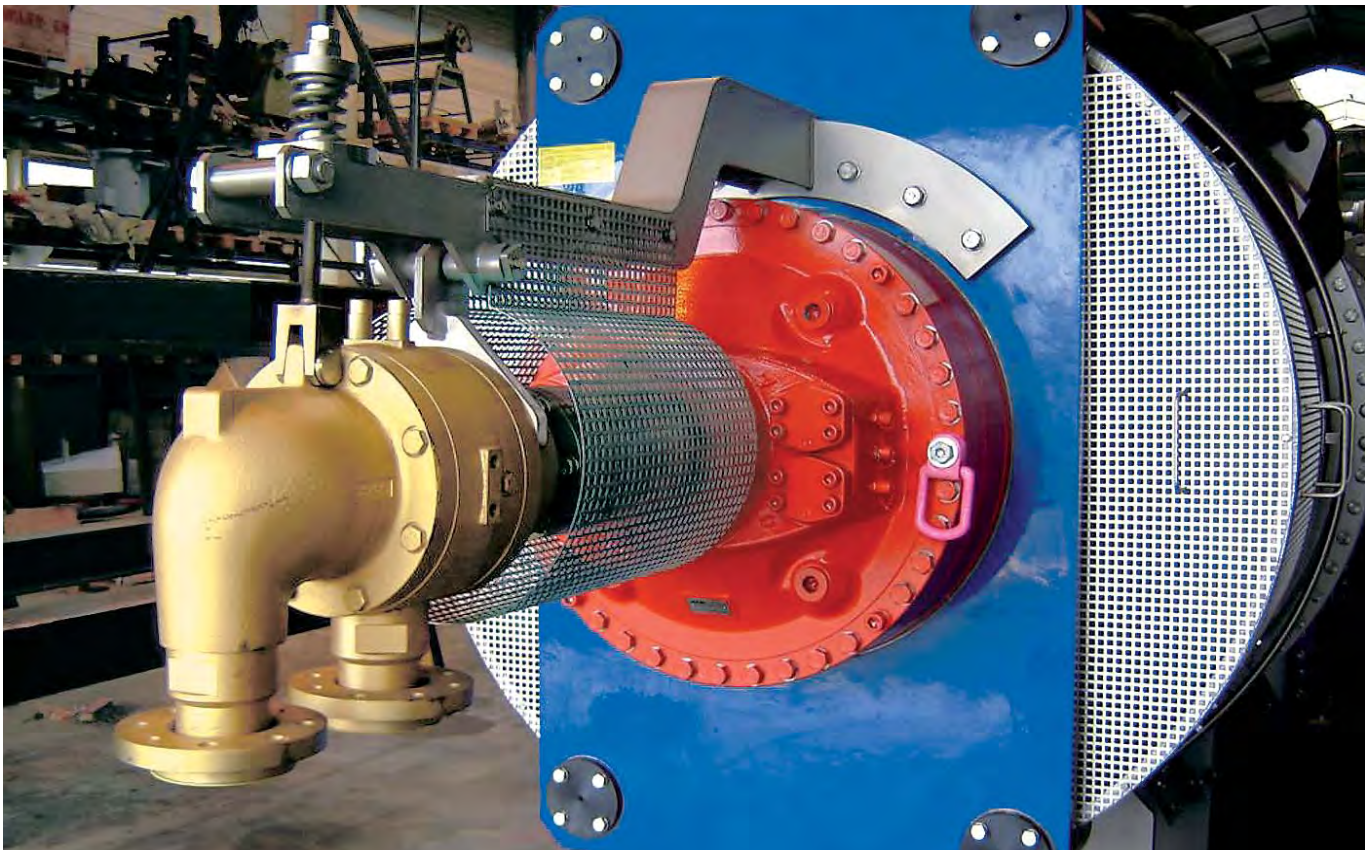
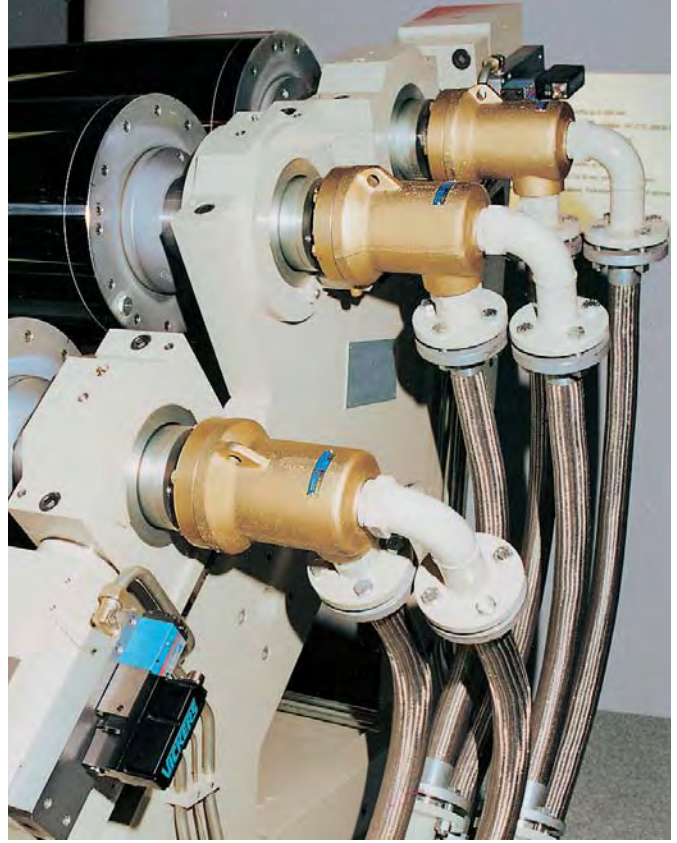
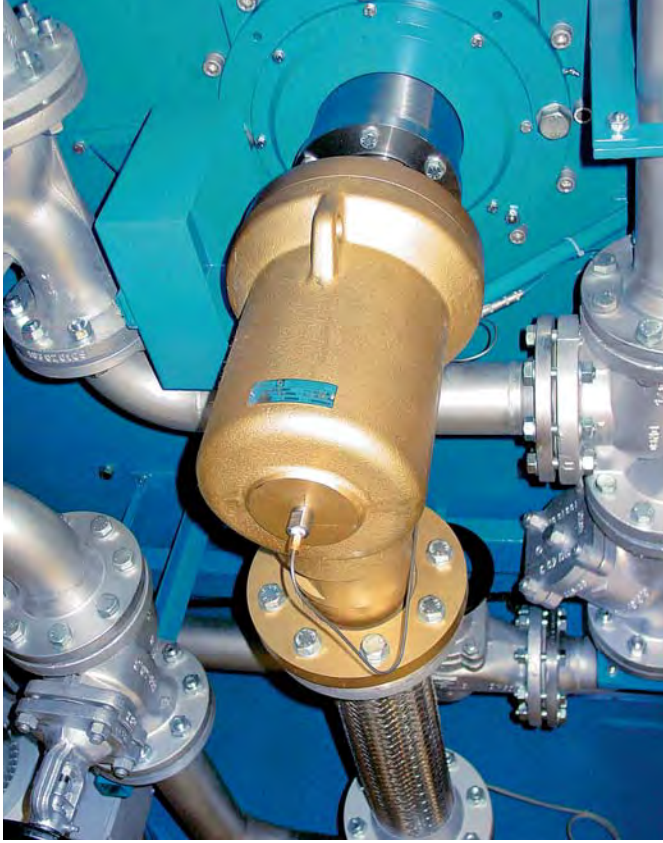

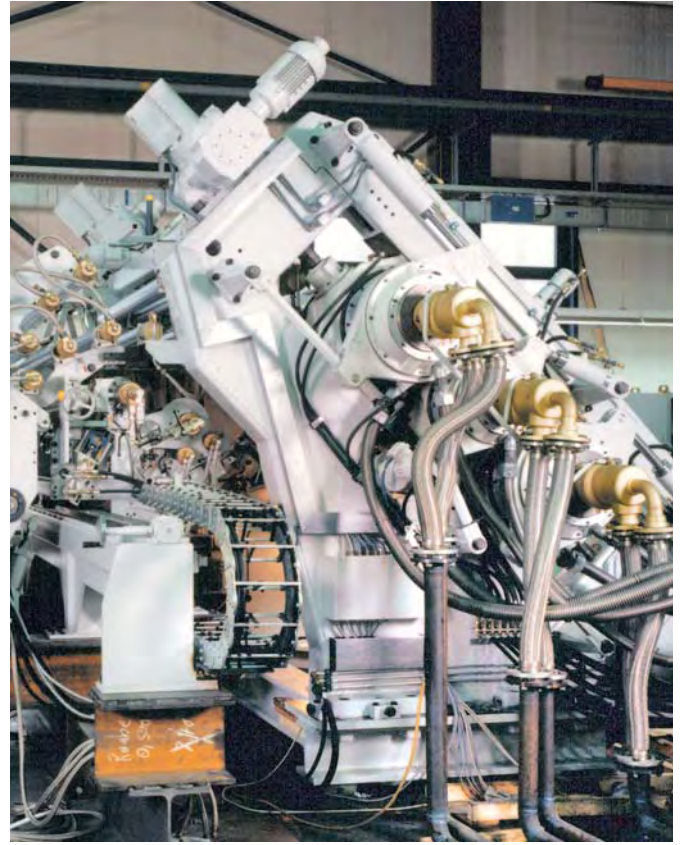



**Christian Maier GmbH & Co. KG
Maschinenfabrik**

Wuerzburger Straße 67-69
D-89520 Heidenheim

P.O.Box 1609
D-89506 Heidenheim

☎ +49 (0) 73 21 / 317-0

✉ +49 (0) 73 21 / 317-139 (Export)

☎ 0 800 / 7 51 82 50

✉ +49 (0) 73 21 / 317-239

vkd@maier-heidenheim.de
www.maier-heidenheim.de

Branch Offices & Service Stations:

Maier Italia Srl

Via Enrico Toti 3
I-21040 Gerenzano (VA)

☎ +39-02-96 24 82 88

✉ +39-02-96 36 96 95

info@maier-italia.com
www.maier-italia.com

Maier America LLC

6649 Peachtree Industrial Blvd., Suite O
Norcross, GA 30092 - USA

☎ +1-770-409 0022

✉ +1-770-409 0069

info@maieramerica.com
www.maieramerica.com



novasys group pty ltd

po box 1150 mountain gate 3156 australia
31/756 burwood hwy ferntree gully 3156 australia

t: +61 3 9752 3766

f: +61 3 9752 3977

email: sales@novasys.com.au

website: www.novasys.com.au