

Operating Instructions Maier Rotary Joints

Series H / HW – DN 15 – 100 (1/2" - 4")

B-H(1)_en - Version 6 – 18.06.2010



Christian Maier GmbH & Co. KG Maschinenfabrik

Würzburger Str. 67-69 Postfach 16 09
D-89520 Heidenheim D-89506 Heidenheim

☎ +49 7321 317-0; 📠 +49 7321 317-139; ✉ vkd@maier-heidenheim.de; 🌐 www.maier-heidenheim.de



Contents

1	Safety	2
2	Design and functions	3
3	Information on design and mounting.....	5
4	Transportation and storage.....	5
5	Mounting.....	6
6	Operation.....	8
7	Maintenance	9

Christian Maier GmbH & Co. KG reserves the copyright to this manual. The instructions, information and illustrations contained in this manual may not be copied in any way, neither partially nor completely. Neither may the instructions, information and illustrations be disclosed to third parties nor used to create competing products, systems or facilities or assist in such activities in any way.

Operating Instructions Maier Rotary Joints

Series H / HW

B-H_en -Version 3 – 11.01.2010

1 Safety

1.1 Application

Maier rotary joints may only be used as fittings to connect pressurized pipes carrying liquids to rotating pressure systems. Such rotating pressure systems are, for example, rollers through which liquids, gas or steam flow for cooling or heating purposes. **Please refer to the section "Specifications and Spare Parts" for details on approved media and their qualities/properties.** These values are binding for the application. Other media are possible - please contact the manufacturer.

Never modify the rotary joint or tamper with it in any way as this may cause dangers. Install, operate and maintain the rotary joint only as described in these operating instructions. We shall not be liable for any damages or plant interruptions whatsoever resulting from failure to observe these operating instructions.

These operating instructions do not contain all information important for the safe operation of the rotary joint. Also observe all pertinent local and national regulations and legislation concerning workplace safety and prevention of accidents.

Use only genuine or Maier-approved spare parts (standard norm parts). If you use other parts, this may have adverse effects on the safety of the rotary joint. We shall not be liable for any damages whatsoever resulting from the use of such non-approved or non-genuine parts.

1.2 Requirements concerning installation and maintenance staff as well as operators

Only staff who has read and fully understood these operating instructions and who is fully aware of the dangers as well as the appropriate safety measures may work with Maier rotary joints. Such staff must have at least the knowledge of a trained locksmith or industrial mechanic who has experience with pressurized components.

1.3 Dangers



Warning!

Touching hot parts or coming into contact with hot liquids escaping under high pressure may result in dangerous burns.

⇒ **Mount a protective hood to the rotary joint in order to prevent persons from directly coming into contact with hot parts and to safely retain escaping media.**



Warning!

If the rotary joint blocks and rotates along with the roller, the hoses may be torn off and hot liquids can escape under high pressure.

⇒ **Always observe the design and mounting information in chapter 3. Monitor the rotary joint by means of a torque sensor or a vibration sensor. Ensure that the rotary joint is regularly maintained as per chapter 7.**

1.4 Safety precautions

Always observe the following safety precautions for the operation of the rotary joint:

- H/HW rotary joints must be overhauled when the wear mark (groove) at the rotor becomes visible (refer to section 7.2 on page 9).

Operating Instructions Maier Rotary Joints

Series H / HW

B-H_en -Version 3 – 11.01.2010

2 Design and functions

2.1 Components

- B, C Housing connections for the medium.
Only one connection for mono flow version.
- D Sealing element (sealing cone, flat packing or O-ring)
- G Housing, stationary flow
- I Inner pipe for duo version
- L Rotor, rotates with the roller
- R Antirotation fork
- W Roller
- DR Sealing ring
- GL Slide bearing

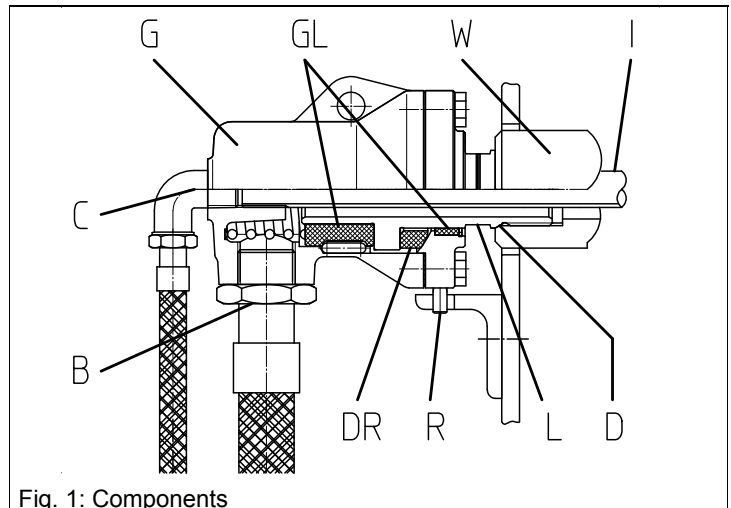

Fig. 1: Components

2.2 Functions and versions

Maier rotary joints are fittings used to connect pressurized pipes to rotating pressure systems. Such rotating pressure systems are, for example, rollers through which liquids, gases or steamflow for cooling or heating purposes.

Rotor "L" is the part that rotates with the roller while housing "G" is the stationary part of the rotary joint. The housing is supported by two slide bearings "GL" at the rotor made of artificial carbon. A special sealing ring "DR" made of artificial carbon is used to seal the medium against the atmosphere at the transition point from the stationary to the rotating parts. Wear of the sealing ring causes an axial movement of the housing (away from the roller). This movement must not be obstructed or prevented, otherwise malfunctions will occur. Antirotation fork "R" is used to prevent rotation of the housing.

Series H / HW rotary joints are available in different housing and rotor versions.

Housing connections:

The following rotary joint versions are available:

Mono flow version: housing with one connection for supplying or removing the medium to or from the rotating pressure system (version 1)

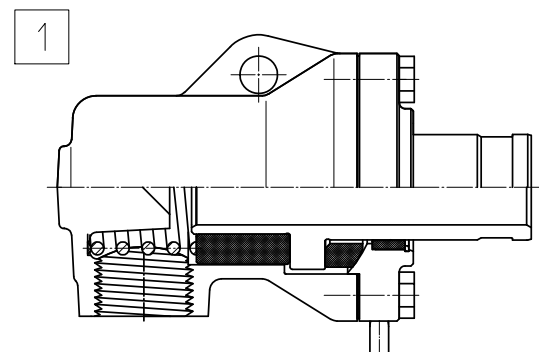

Operating Instructions Maier Rotary Joints

Series H / HW

B-H_en -Version 3 – 11.01.2010

Duo flow version: housing with two connections for supplying and removing the medium to and from the rotating pressure system. The second channel is formed by an inner pipe that is centered in the center axis of the rotating part.

The design of the inner pipe differs in terms of the following versions:

- Stationary inner pipe (version 2 or X 2): The inner pipe is screwed into the housing or the elbow (standard version always with right-hand thread).
- Rotating inner pipe supported in housing (version R 2): The internal pipe is supported by a self-lubricating slide bearing in the stationary housing. There is wear at the bearing point.
- Rotating inner pipe for static bearing in the rotating part of the rotary joint (rotor) (versions A 2 and B 2): The inner pipe is held by a bushing in the rotor (version A 2: for precise separation of supply and return with additional sealing; version B 2: gap seal). There is no wear at the bearing point.

Three way version: Housing with three connections for supplying steam, removing condensate and vacuum valve as negativepressure safety device for thin-walled dry cylinders.

Two inner pipe designs are available: versions 3 and R 3 (see duo flow version).

Rotor connections:

The connection to the rotating pressurized system is made by the rotating part of the rotary joint – the rotor. The rotor is mounted to the rotating pressure system (e.g. a roller) by means of a right-hand or left-hand thread R / L or a flange K. The system is sealed by means of a sealing cone, flat packing or an O-ring.

Please refer to our catalog and the corresponding drawing for further information.

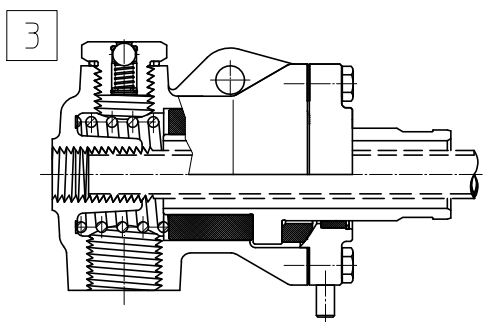
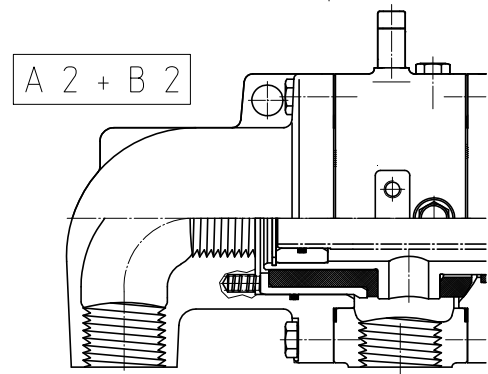
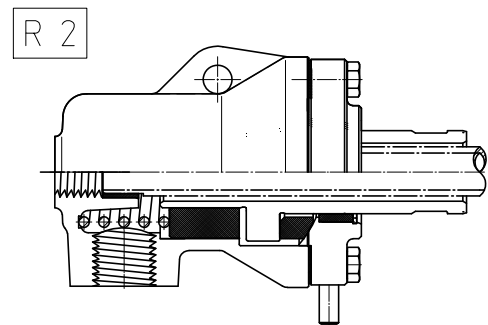
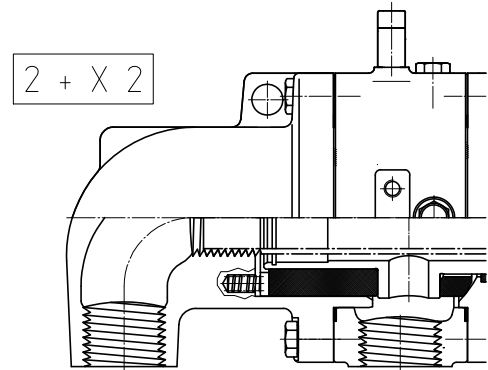

R / L

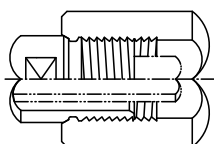

K

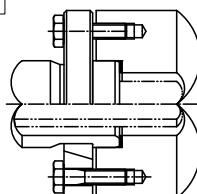

Operating Instructions Maier Rotary Joints

Series H / HW

B-H_en -Version 3 – 11.01.2010

3 Information on design and mounting

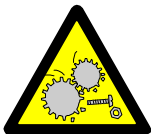
**Attention!****Damage to components due to vibration and heat expansion.**⇒ **Use only flexible hoses to connect the rotary joint!**

- Use flexible elements (metal hoses or joint compensators for DN > 125 / 5") for the connection between the supply pipe system and the rotary joint housing. This compensates for heat expansion and vibrations.
- Never apply torsional, tensile or pressure forces to metal hoses. Observe the minimum bending radii quoted by the hose manufacturers. Never use axial compensators without strain relief since the hydraulic response forces would destroy the bearing point in the rotary joint.
- Use flat packings made of pure graphite to securely seal flange connections.
- Only operate the rotary joint with a sufficiently dimensioned torque support to prevent rotation of the housing. The support element must allow for axial and radial movements of the housing. If the axial movement is obstructed due to wear at the sealing ring (away from the roller), leakage will occur.
- Install an additional safety unit:
Install a torque monitoring system or a bearing monitoring system with connection to the emergency shutdown system in order to avoid bearing damages and consequential damages. Please refer to the section "Specifications and Spare Parts" for details on the maximum admissible friction torque.
If the monitoring system is activated, the rotation of the roller should be stopped immediately and the supply of the medium should be interrupted from the flexible supply elements.
- Center the inner pipe and the roller as well as the rotary joint. Out- of-round and axial tension will lead to malfunctions of the rotary joint.
- For smooth operation of rotary joint ensure concentricity and minimum out-of-round tolerance at roller or intermediate flange.
- In the case of a rotary joint with rotating inner pipe – version HR / HWR - it is recommended to use a stainless steel inner pipe or at least a hard chromium-plated bearing seat.
- Series H / HW are mostly used for water, steam and thermal oil. In order to ensure maximum reliability and service life of the seals in the rotary joint, the media used should conform to the specifications listed in "Specifications and Spare Parts". Please inquire for other media.
- Special versions:
See the part "Specifications and Spare Parts" of the operating instructions for additional information on proper and safe operation.

4 Transportation and storage

- Use suitable lifting gear to transport rotary joints weighing more than 25 kg (55 lbs).
- The rotary joints may only be stored in the original packing.
- Make sure the storage conditions specified in the "Specifications and Spare Parts" are met.
- If the rotary joint itself or the facility in which the rotary joint is installed is to be preserved, make sure the preservation agent and the seals of the rotary joint are compatible.

Operating Instructions Maier Rotary Joints

Series H / HW

B-H_en -Version 3 – 11.01.2010

5 Mounting

5.1 Mounting the rotary joint to the roller

- For duo flow version, mount the inner pipe J as described:
H 2 / HW 2: screw it into the housing.
HR 2 / HWR 2: insert it into the slide bearing (center it, avoid tension).
HWB 2 / HWA 2: insert it into the rotor. Do not damage the O- ring in the rotor (version HWA 2)!
- Mount rotary joint 1 to roller W:
as per drawing A with thread at rotor
as per drawing B with K flange 2 and inner ring 3
- Seal with a sealing cone DF (for rotor with thread R/L) or flat packing 7 (for rotor with K flange).
- Fasten the rotary joint with screw 8 or stud bolt 9 and nut 10.
- Clean sealing surfaces DF, apply mounting paste and place the sealing element into roller W (drawings B).
- Recommended material for flat packing:
pure graphite with metal mesh.
- Mount K flange 2 with screws over rotor 80 and place inner ring 3 into rotor groove.
- Lift the rotary joint and insert it into the centering unit of the roller.
Versions with inner pipe: the inner pipe must be centered to the rotary joint and the roller. If you encounter resistance, check for correct position. Out-of-round and axial tension cause malfunctions of the rotary joint.
- Mount screws 8 or nuts 10. Maximum admissible torque as per "Specifications and Spare parts".

Attention:

- When sealing with flat packing, do not fully tighten the screws until you have aligned the rotary joint as per section 5.2!
- Assure the minimum distance $MA \geq 1 \text{ mm (0.04")}$ - otherwise leakage will occur at the sealing element and the rotary joint and the inner pipe will be damaged.



Note:
For smooth operation of rotary joint ensure concentricity and minimum out-of-round tolerance of roller.

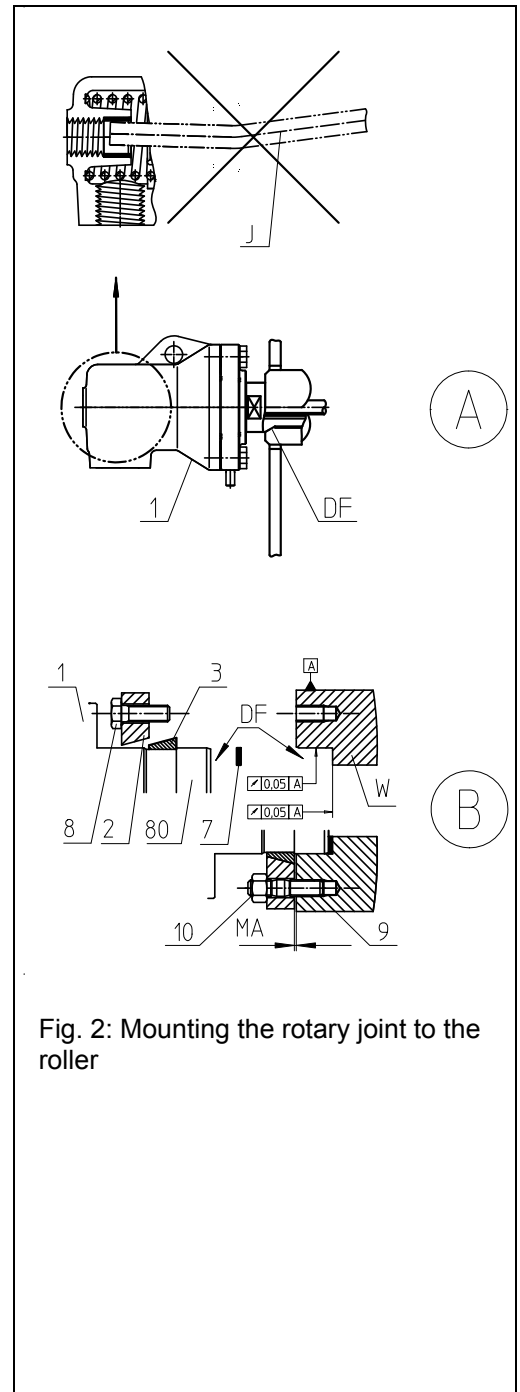

Fig. 2: Mounting the rotary joint to the roller

Operating Instructions Maier Rotary Joints

Series H / HW

B-H_en -Version 3 – 11.01.2010

5.2 Aligning the rotary joint, sealing with flat packing

- Place dial gauge M from the idle machine frame MG onto the rotary joint.
- Rotate roller W until the dial gauge is at the bottom dead center UT. Mark the pointer position.
- Rotate roller until you reach the upper dead center OT.
- Tighten the bottom screws Su until the dial gauge is in the center position.
- Repeat this alignment process until you reach the concentricity tolerance specified in the table.
- Tighten the screws with the admissible torque as per "Specifications and Spare Parts"!

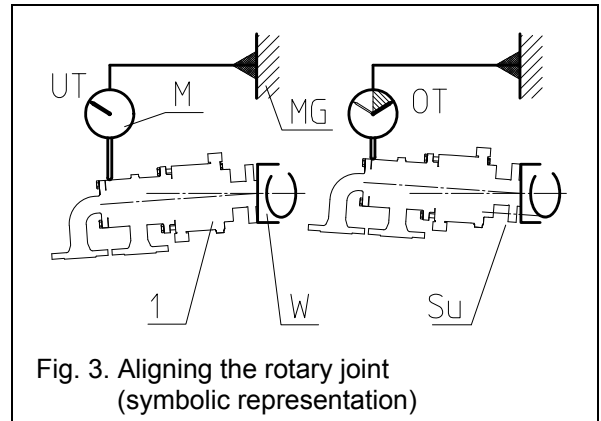
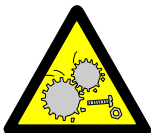

Fig. 3. Aligning the rotary joint (symbolic representation)

Admissible concentricity tolerance

DN mm	DN inch	n (min ⁻¹) rpm		
		≤ 40	≤ 100	> 100
15-50	½ - 2	± 1 mm ± 0.04"	± 0.5 mm ± 0.02"	± 0.2 mm ± 0.0078"
65-100	2½ - 4			
125-300	5 - 12			

5.3 Connecting the rotary joint



Attention!

The rotary joints must never run dry since this may damage the sealing components. Exception: test run for a maximum of 30 minutes at a very low speed.

- Mount anti-rotation device 3 of the rotary joint housing / torque monitoring system.
- Connect the housing.
- Special versions:
See the part "Specifications and Spare Parts" of the operating instructions for additional information on proper and safe operation.
- Route the hoses as shown in fig. 4.
- Do not route the hoses as shown in fig. 5.

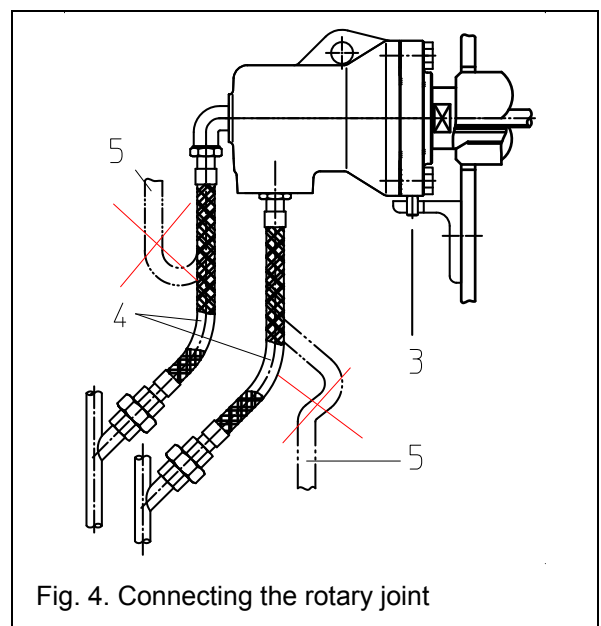

Fig. 4. Connecting the rotary joint



Observe the information in section 3!

Operating Instructions Maier Rotary Joints

Series H / HW

B-H_en -Version 3 – 11.01.2010

6 Operation



Attention!

Danger of damage to the rotary joint if it is not operated as per instructions.

- ⇒ **Never operate the rotary joint beyond the application data limits specified in "Specifications and Spare Parts"!**
- ⇒ **Observe the limitations specified in section 1.1 on page 2!**

6.1 Observe and check during operation

Check the following during operation:

- Check for concentric arrangement of the rotor to the roll journal. The radial run-out at the rear area of the housing must not exceed the limits listed in section 5.2. Place a dial gauge from the idle machine frame onto the rotary joint housing to check.
- Check the quality of the medium in the system and record the values.
- Check the rotary joint for visible leaks. The operating behavior of the seal installed does not change suddenly. If the seal is beginning to fail, this is indicated by slowly increasing leakage. Regular checks allow you to acquire experience values concerning the operating behavior of the rotary joint installed in the system.
- Special versions:
See the part "Specifications and Spare Parts" of the operating instructions for additional information on proper and safe operation.

6.2 Trouble shooting

Problem	Reason	Repair
Leakage	<ul style="list-style-type: none"> – Seal damaged or worn out. – Obstruction of the axial motion (up to 15 mm / 0.59") caused by wear or heat expansion. 	<ul style="list-style-type: none"> – Completely overhaul the rotary joint! – Check hoses and anti-rotation unit (obstruction is not permitted)
Friction torque too high	<ul style="list-style-type: none"> – Application data exceeded (pressure, temperature, speed) 	<ul style="list-style-type: none"> – Avoid the combination of maximum values.

Operating Instructions Maier Rotary Joints

Series H / HW

B-H_en -Version 3 – 11.01.2010

7 Maintenance

7.1 Safety during maintenance

Only staff who has read and fully understood these operating instructions and who is fully aware of the dangers as well as the appropriate safety precautions may work with Maier rotary joints. Such staff must have at least the knowledge of a trained locksmith or industrial mechanic who has experience with pressurized components.

Perform work on the rotary joint only when the machine/system is idle.

Allow the rotary joint to cool down before you take up work or wear safety equipment to protect against the heat.

Always wear safety glasses when performing work on the rotary joint to protect against escaping medium.

Use only genuine or Maier-approved spare parts (standard norm parts). If you use other parts, this may have adverse effects on the safety of the rotary joint. We shall not be liable for any damage whatsoever resulting from the use of such non-approved or non-genuine parts.

Maier offers on site specialist service. We can also train your service staff - just get in touch with us!

If you have to remove protective equipment to perform the work, reinstall such equipment when you are done and check it for proper operation.

Make sure to properly tighten all screws (see sheet "Specifications and Dimensions").

Always observe the safety information in chapter 1 on page 2.

7.2 Maintenance plan

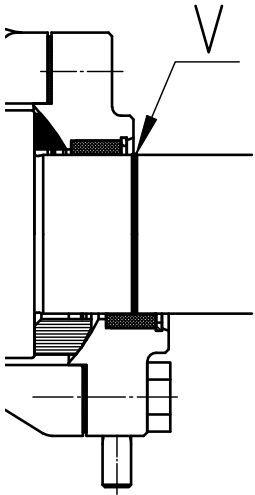
Interval	Activity	Explanation
Every 12 months	<p>If groove "V" (indicates wear) is visible at the rotor, overhaul the rotary joint.</p> 	By Maier customer service.

Rotary joints series H – HW feature carbon bearings and thus do not require relubrication.

Specifications and Spare Parts

Series H / HW – DN 15 – 100 (1/2" - 4")

S-H(1)_en -Version 6– 18.06.2010

Contents

Table 1: Application data.....	1
Table 1: Application data.....	2
Table 2: Speed limitation of formula values.....	2
Table 3: Transportation and storage.....	2
Table 4: Tightening Torques for Fastening Screws.....	3
Approved media for the pressure pipe.....	4
Specifications - standard media.....	4
Friction torque.....	5
H 1 + HW 1, monoflow, DN 15-100 (1/2" – 4").....	6
H 2 + HW 2, duoflow with stationary inner pipe, DN 15-100 (1/2" – 4").....	7
HR 2 + HWR 2, duoflow with rotating inner pipe, DN 15-100 (1/2" – 4").....	8
H 3 + HW 3, duoflow with rotating inner pipe and vacuum valve, DN 25-40 (1" – 1 1/2").....	9
HW 1 Series -450, monoflow, rotor material 1.4571 (SS 316 Ti), DN 15-25 (1/2" – 1").....	10
HW 1 Series -500, monoflow, rotor material 1.4571 (SS 316 Ti), DN 32-100 (1 1/4" – 4").....	11
HW 2 + HWR 2 Series -450, duo flow, rotor material 1.4571 (SS 316 Ti), DN 20+25 (3/4" + 1").....	12
HWX 2, duoflow, stationary inner pipe, DN 32-100 (1 1/4" – 4").....	13
HWB 2, duoflow, rotating inner pipe, DN 32-100 (1 1/4" – 4").....	14
HWA 2, duoflow, rotating inner pipe, DN 32-100 (1 1/4" – 4").....	15
HWX 2 + HWB 2 + HWA 2 Serie -500, duoflow, DN 32-100 (1 1/4" – 4").....	16
Spare parts H 1 + HW 1, H 2 + HW 2, HR 2 + HWR 2, DN 15-100 (1/2" – 4"); H 3 + HW 3, DN 25-40 (1" – 1 1/2").....	17
Spare parts HWX 2 / HWB 2 + HWA 2, DN 32-100 (1 1/4" – 4").....	18

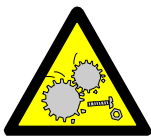

Attention!

Danger of damage if the rotary joint is not operated as per instructions.

- ⇒ **The specifications listed in this document are binding.**
- ⇒ **Never operate the rotary joint beyond the application data specified!**
- ⇒ **Use only approved media!**

We shall not be liable for any damage whatsoever caused by failure to adhere to limit values or use of unsuitable media!

Table 1: Application data

Type		H	HW			HW		HW	
Version		1, 2, R2, 3	1, 2, R2, 3			X2, A2		B2	
Nominal diameter DN	[mm]	15...100	15...100			32 ... 100		32 ... 100	
Nominal diameter DN	[inch]	1/2...4	1/2...4			1 1/4 ... 4		1 1/4 ... 4	
Version		---	---			---		---	
Nominal diameter DN	[mm]								
Nominal diameter DN	[inch]								
Medium		Water, steam	Water, steam	Thermal-oil	Water, steam	Thermal-oil	Water	Thermal-oil	
Temperature	min ...max. °C	-10...220	-10 ... 220	-10 ... 300	-10 ... 230	-10 ... 300	-10 ... 230	-10 ... 300	
	min ...max. °F	14...428	14 ... 428	14 ... 572	14 ... 446	14 ... 572	14 ... 446	14 ... 572	
Pressure PN	min.... max. bar	0,8...20	0,8 ... 20	0,8 ... 10	0,8 ... 28	0,8 ... 10	0,8 ... 28	0,8 ... 10	
	min.... max. psi	11.6...290	11.6 ... 290	11.6 ... 145	11.6 ... 406	11.6 ... 145	11.6 ... 406	11.6 ... 145	
Speed	max. min ⁻¹	<u>50 000</u>	<u>100 000</u>			<u>150 000</u>		<u>150 000</u>	
	max. rpm	DN x PN	DN x PN			DN x PN		DN x PN	



Specifications and Spare Parts

Series H / HW – DN 15 – 100 (1/2" - 4")

S-H(1)_en -Version 6– 18.06.2010

Table 1: Application data

Type		HW -450		HW -500		HW -500		HW -500	
Version		1		1		X2, A2		B2	
Nominal diameter DN	[mm]	15...25		32 ... 100		32 ... 100		32 ... 100	
Nominal diameter DN	[inch]	1/2...1		1 1/4 ... 4		1 1/4 ... 4		1 1/4 ... 4	
Version		2, R2		---		---		---	
Nominal diameter DN	[mm]	20+25		---		---		---	
Nominal diameter DN	[inch]	3/4+1		---		---		---	
Medium		Water, steam	Thermal- oil	Water, steam	Thermal- oil	Water, steam	Thermal- oil	Water	Thermal- oil
Temperature	min ...max. °C min ...max. °F	-10 ... 220 14 ... 428	-10 ... 300 14 ... 572	-10 ... 250 14 ... 482	-10 ... 300 14 ... 572	-10 ... 230 14 ... 446	-10 ... 300 14 ... 572	-10 ... 230 14 ... 446	-10 ... 300 14 ... 572
Pressure PN	min.... max. bar min.... max. psi	0,8 ... 20 11.6 ... 290	0,8 ... 10 11.6 ... 145	0,8 ... 20 11.6 ... 290	0,8 ... 10 11.6 ... 145	0,8 ... 28 11.6 ... 406	0,8 ... 10 11.6 ... 145	0,8 ... 28 11.6 ... 406	0,8 ... 10 11.6 ... 145
Speed	max. min ⁻¹ max. rpm	100 000 DN x PN		100 000 DN x PN		150 000 DN x PN		150 000 DN x PN	

Avoid operating the unit under conditions involving several maximum values attained at the same time! Inquire for greater values and other media.

Table 2: Speed limitation of formula values

DN [mm]	15	20	25	32	40	50	65	75	80	100
DN [inch]	1/2	3/4	1	1 1/4	1 1/2	2	2 1/2	3	3 1/2	4
Max. speed	min ⁻¹ rpm	470	400	340	420	370	350	300	250	200

Table 3: Transportation and storage

Storage temperature	15 °C to 30 °C 59 °F bis 86 °F
Humidity	65 %
Preservation	none; check compatibility with seal materials, if necessary

Specifications and Spare Parts

Series H / HW – DN 15 – 100 (1/2" - 4")

S-H(1)_en -Version 6– 18.06.2010

Table 4: Tightening Torques for Fastening Screws in Nm (ft lbf) with friction in the thread and connecting surface with $\mu = 0,14$ and ...

Property class 5.6 at a screw temperature of						
Size	20°C 68°F	100°C 212°F	150°C 302°F	200°C 392°F	250°C 482°F	300°C 572°F
M 6	4,0 (2.95)	3,6 (2.66)	3,4 (2.51)	3,1 (2.29)	2,9 (2.14)	2,7 (1.99)
M 8	10,0 (7.38)	9,0 (6.64)	8,5 (6.27)	7,9 (5.83)	7,3 (5.38)	6,6 (4.87)
M 10	18 (13.28)	16 (11.80)	15 (11.06)	14 (10.33)	13 (9.59)	12 (8.85)
M 12	37 (27.29)	33 (24.34)	31 (22.86)	29 (21.39)	26 (19.18)	24 (17.70)
M 16	90 (66.38)	81 (59.74)	76 (56.05)	71 (52.37)	65 (47.94)	60 (44.25)
M 20	175 (129.07)	158 (116.53)	148 (109.16)	138 (101.78)	127 (93.67)	116 (85.56)
Property class 8.8 at a screw temperature of						
Size	20°C 68°F	100°C 212°F	150°C 302°F	200°C 392°F	250°C 482°F	300°C 572°F
M 6	10,0 (7.38)	9,3 (6.86)	8,9 (6.56)	8,4 (6.20)	8,0 (5.90)	7,5 (5.53)
M 8	24,0 (17.70)	22,3 (16.45)	21,3 (15.71)	20,3 (14.97)	19,1 (14.09)	18,0 (13.28)
M 10	48 (35.40)	45 (33.19)	43 (31.72)	41 (30.24)	38 (28.03)	36 (26.55)
M 12	82 (60.48)	76 (56.05)	73 (53.84)	69 (50.89)	65 (47.94)	62 (45.73)
M 16	206 (151.94)	192 (141.61)	183 (134.97)	174 (128.34)	164 (120.96)	155 (114.32)
M 20	400 (295.02)	372 (274.37)	355 (261.83)	338 (249.30)	319 (235.28)	300 (221.27)

The property class is indicated by the designation of the fastening element. Please inquire for data on other materials.

Specifications and Spare Parts

Series H / HW – DN 15 – 100 (1/2" - 4")

S-H(1)_en -Version 6– 18.06.2010

Approved media for the pressure pipe

Series H / HW may be used for water, steam and thermal oil having the quality described below. Other media including additives (e.g. anticorrosion or antifreeze agents) must be checked for compatibility with the sealing materials in the manufacturer's plant.

Specifications - standard media

General

The quality of the medium used plays a decisive role in the service life and reliability of Maier rotary joints. It is strongly recommended to observe the specifications listed below. Insufficient quality of the medium will result in heavy wear of the sealing and premature failure of the rotary joint.

Section 1: Water at temperatures -10°C to 70°C (14°F to 158°F)

- Raw water: drinking water quality
- General: clear, no sediments
- Filtration: particle size 20 µm (788µin), max. 50µm (1969 µin)
- Water hardness: < 3,2 mmol/l (322 ppm CaCO₃)
- If required, add a suitable antifreeze agent and a **silicate-free** anticorrosion agent (ensure compatibility with the materials used in the unit, check back with manufacturer, if necessary).

Section 2: Water at temperatures of ≥ 70°C (158°F) and boiler water for steam ≤ 220°C (428°F)

- Raw water: drinking water quality
- General: clear, no sediments
- Filtration: particle size 20 µm (788µin), max. 50µm (1969 µin)
- Water hardness: < 3,2 mmol/l (322 ppm CaCO₃)
- Low salt concentration according to VdTÜV- Guideline TCh 1466 "Guideline for Circulation Water in Hot Water and Warm Water Heating Systems" ("Richtlinie für das Kreislaufwasser in Heißwasser – und Warmwasserheizungsanlagen), sheet 1
- If required, add a suitable antifreeze agent and a **silicate-free** anticorrosion agent (ensure compatibility with the materials used in the unit, check back with manufacturer, if necessary).

Section 3: Thermal oil

- Material groups:
 1. Thermal oil consisting of hydrocarbons (mineral base, group 1)
 2. Thermal oil made of isomer mixture (synthetic base – group 2)

Only upon request
Thermal oil consisting of uniform material (synthetic base – group 3)
 - General: clear, no sediments
 - Filtration: particle size 50 µm (1969 µin), max. 100µm (3937 µin)
 - Steam pressure*: The steam pressure must not exceed 0.5 bar (7.25 psi) abs at maximum operating temperature.
- *: Steam pressure is the pressure at which a liquid becomes gaseous. The steam pressure depends on the temperature of the liquid.
- Specific heat conductivity: For maximum heat dissipation in the sealing gap, the value should be as good as possible.
 - Kinematic viscosity: For excellent flow in the system and lubrication effect in the rotary joint, the following values should be attained:
 - as low as possible at minimum application temperature
 - as high as possible at maximum application temperature.

Please inquire for media not listed.



Specifications and Spare Parts

Series H / HW – DN 15 – 100 (1/2" - 4")

S-H(1)_en -Version 6– 18.06.2010

Friction torque

Friction torque is essential in designing drives and the safety device for torque monitoring. The values listed relate to measurements with water at 20°C (68°F). The operating pressure is the main factor of influence on the friction torque – in addition, speed, operating pressure and the medium play a role, but to a lesser degree. Therefore, variations of up to ± 20% are possible. The initial breakaway torque during commissioning and after longer idle periods may be twice as high as the values listed.

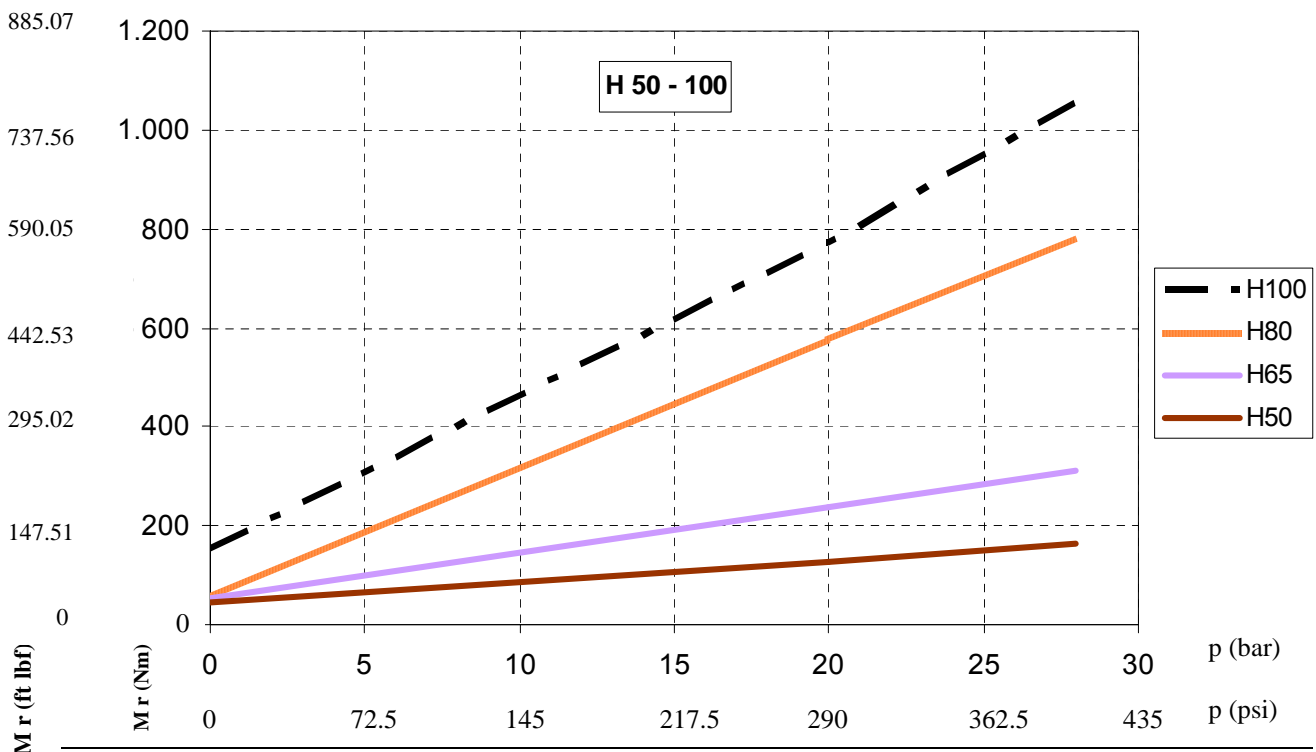
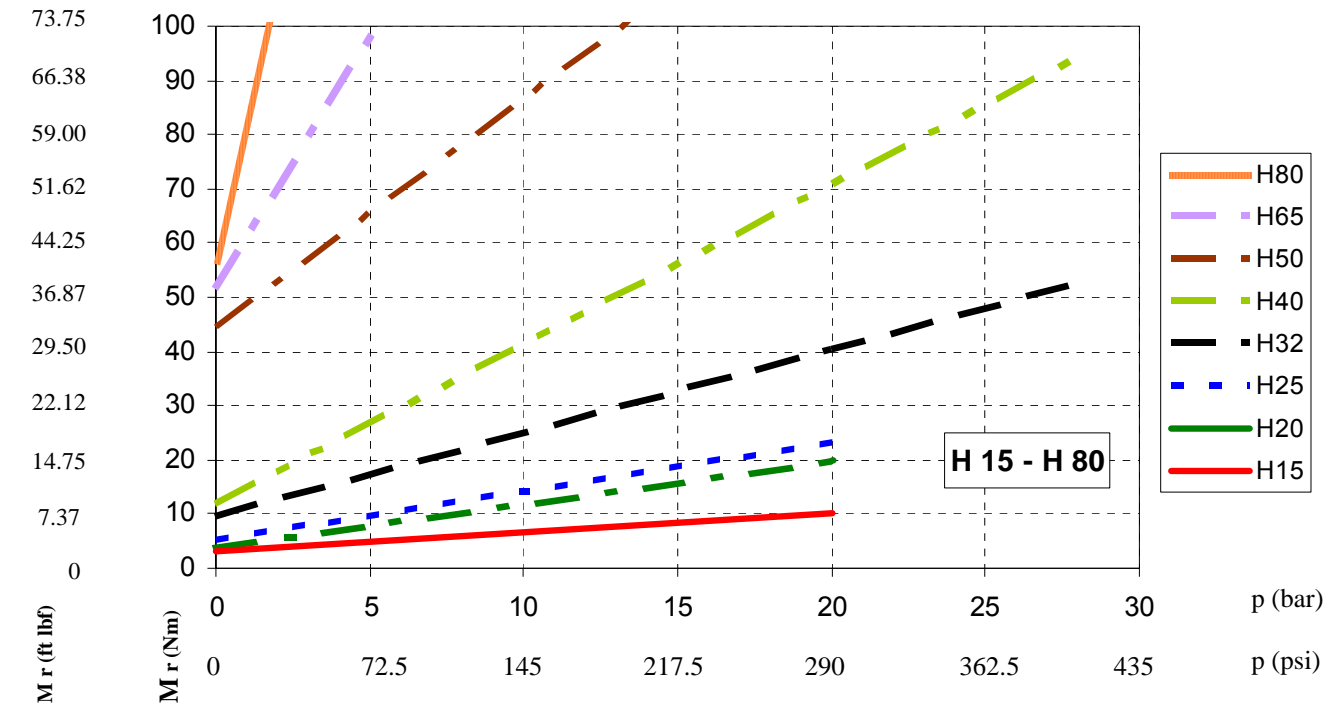

Specifications and Spare Parts

Series H / HW – DN 15 – 100 (1/2" - 4")

S-H(1)_en -Version 6– 18.06.2010

H 1 + HW 1, monoflow, DN 15-100 (1/2" - 4")

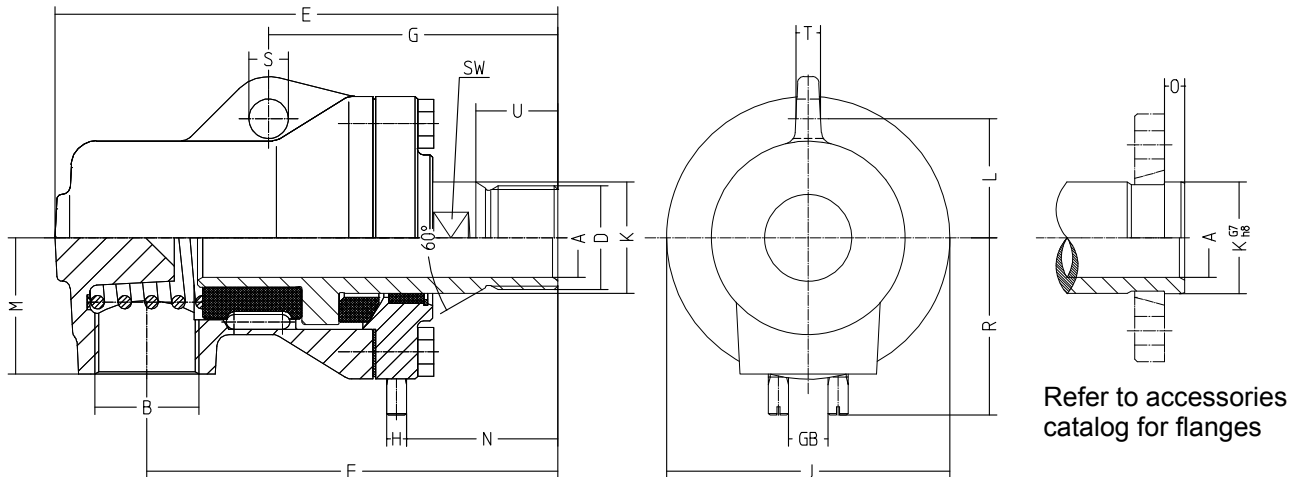

DN mm DN inch Δ dim A	15 1/2	20 3/4	25 1	32 1 1/4	40 1 1/2	50 2	65 2 1/2	80 3 1/2	100 4
Type	H 115 R	H 120 R	H 125 R	H 132 R	H 140 R	H 150 R	H 165 R	H 180 R	H 1100 R
Ordering no.	1108050	1108130	1108210	1108350	1108450	1108550	1108650	1108750	1108850
Type	H 115 L	H 120 L	H 125 L	H 132 L	H 140 L	H 150 L	H 165 L	H 180 L	H 1100 L
Ordering no.	1108051	1108131	1108211	1108351	1108451	1108551	1108651	1108751	1108851
Type	H 115 K	H 120 K	H 125 K	H 132 K	H 140 K	H 150 K	H 165 K	H 180 K	H 1100 K
Ordering no.	1108052	1108132	1108212	1108352	1108452	1108552	1108652	1108752	1108852
Type	HW 115 R	HW 120 R	HW 125 R	HW 132 R	HW 140 R	HW 150 R	HW 165 R	HW 180 R	HW 1100 R
Ordering no.	1108065	1108145	1108165	1108366	1108465	1108565	1108665	1108765	1108865
Type	HW 115 L	HW 120 L	HW 125 L	HW 132 L	HW 140 L	HW 150 L	HW 165 L	HW 180 L	HW 1100 L
Ordering no.	1108066	1108146	1108166	1108367	1108466	1108566	1108666	1108766	1108866
Type	HW 115 K	HW 120 K	HW 125 K	HW 132 K	HW 140 K	HW 150 K	HW 165 K	HW 180 K	HW 1100 K
Ordering no.	1108067	1108147	1108169	1108368	1108467	1108567	1108667	1108767	1108867

Ø A	13	20	24,5	32	38	50	66	81	98
B	G 1/2	G 3/4	G 1	G 1 1/4	G 1 1/2	G 2	G 2 1/2	G 3	G 4
D	G 1/2 A	G 3/4 A	G 1 A	G 1 1/4 A	G 1 1/2 A	G 2 A	G 2 1/2 A	G 3 1/2 A	G 4 A
E	130	146	174	203	226	275	327	398	480
F	107	120	143	167	183	225	264	320	383
G	85	91	104	118	124	146	165	203	243
H	6	6	8	8	10	16	18	18	25
Ø J	80	88	97	114	124	144	182	220	260
Ø K	25	30	35	45	52	66	85	107	118
Ø K G7/h8	24	30	35	45	50	65	85	105	114
L	31	36	40	48	53	62	80	100	115
M	34	42	48	55	65	80	90	115	135
N	44	49	53	63	66	81	93	121	143
O	6	8	8	8	10	10	10	12	12
R	52	56	64	74	82	92	115	135	168
S	12	12	12	16	16	18	20	22	26
T	7	8	9	10	12	13	15	20	22
U	23	23	28	33	36	43	48	54	66
GB	12	12	14	16	16	18	20	22	26
SW	22	27	30	41	46	60	75	95	110
Weight kg (lbs)	1,7 (3.74)	2,4 (5.29)	3,4 (7.49)	5,5 (12.12)	7,1 (15.65)	11,3 (24.91)	21,4 (47.17)	37,9 (83.55)	62 (136.68)

Specifications and Spare Parts

Series H / HW – DN 15 – 100 (1/2" - 4")

S-H(1)_en -Version 6– 18.06.2010

H 2 + HW 2, duoflow with stationary inner pipe, DN 15-100 (1/2" - 4")

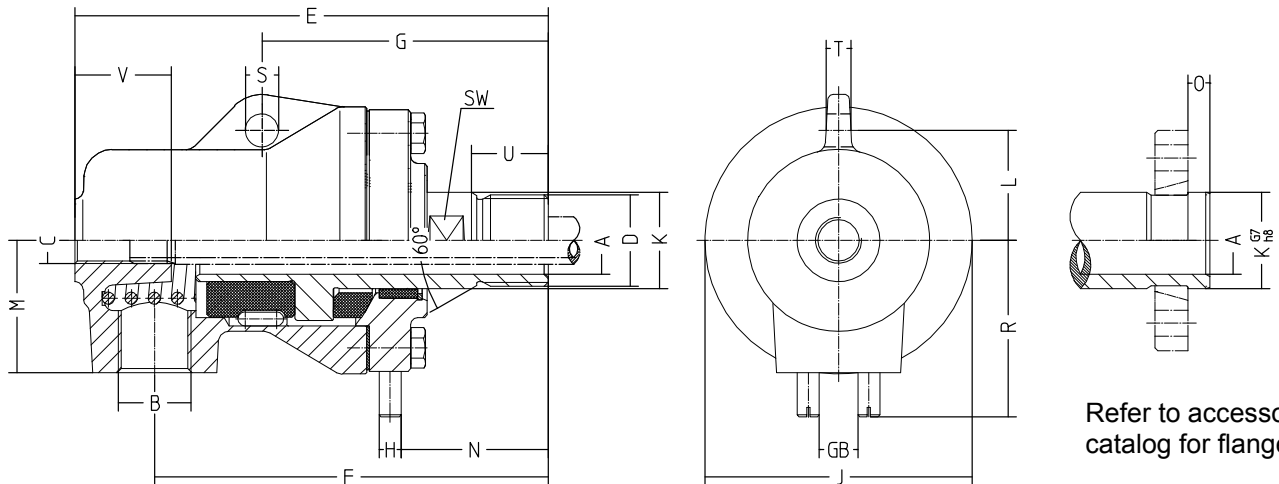

Refer to accessories catalog for flanges

DN mm DN inch dim A	15 1/2	20 3/4	25 1	32 1 1/4	40 1 1/2	50 2	65 2 1/2	80 3 1/2	100 4
Type	H 215 R	H 220 R	H 225 R	H 232 R	H 240 R	H 250 R	H 265 R	H 280 R	H 2100 R
Ordering no.	1108053	1108133	1108213	1108353	1108453	1108553	1108654	1108753	1108853
Type	H 215 L	H 220 L	H 225 L	H 232 L	H 240 L	H 250 L	H 265 L	H 280 L	H 2100 L
Ordering no.	1108054	1108134	1108214	1108354	1108454	1108554	1108655	1108754	1108854
Type	H 215 K	H 220 K	H 225 K	H 232 K	H 240 K	H 250 K	H 265 K	H 280 K	H 2100 K
Ordering no.	1108055	1108135	1108215	1108355	1108455	1108555	1108656	1108755	1108855
Type	HW 215 R	HW 220 R	HW 225 R	HW 232 R	HW 240 R	HW 250 R	HW 265 R	HW 280 R	HW 2100 R
Ordering no.	1108068	1108148	1108167	1108363	1108468	1108568	1108668	1108768	1108868
Type	HW 215 L	HW 220 L	HW 225 L	HW 232 L	HW 240 L	HW 250 L	HW 265 L	HW 280 L	HW 2100 L
Ordering no.	1108069	1108149	1108168	1108364	1108469	1108569	1108669	1108769	1108869
Type	HW 215 K	HW 220 K	HW 225 K	HW 232 K	HW 240 K	HW 250 K	HW 265 K	HW 280 K	HW 2100 K
Ordering no.	1108070	1108150	1108170	1108365	1108470	1108570	1108670	1108770	1108870

Ø A	13	20	24,5	32	38	50	66	81	98
B	G 3/8	G 1/2	G 3/4	G 1	G 1 1/4	G 1 1/2	G 2	G 2 1/2	G 3
C	G 1/8	G 1/4	G 3/8	G 1/2	G 3/4	G 1	G 1 1/2	G 1 1/2	G 2
D	G 1/2 A	G 3/4 A	G 1 A	G 1 1/4 A	G 1 1/2 A	G 2 A	G 2 1/2 A	G 3 1/2 A	G 4 A
E	128	144	172	200	223	272	324	393	475
F	107	120	143	167	183	225	264	320	383
G	85	91	104	118	124	146	165	203	243
H	6	6	8	8	10	16	18	18	25
Ø J	80	88	97	114	124	144	182	220	260
Ø K	25	30	35	45	52	66	85	107	118
Ø K G7/h8	24	30	35	45	50	65	85	105	114
L	31	36	40	48	53	62	80	100	115
M	34	42	48	55	65	80	90	115	135
N	44	49	53	63	66	81	93	121	143
O	6	8	8	8	10	10	10	12	12
R	52	56	64	74	82	92	115	135	168
S	12	12	12	16	16	18	20	22	26
T	7	8	9	10	12	13	15	20	22
U	23	23	28	33	36	43	48	54	66
V	28	32	35	45	50	60	70	80	90
GB	12	12	14	16	16	18	20	22	26
SW	22	27	30	41	46	60	75	95	110
Weight kg (lbs)	1,6 (3.52)	2,3 (5.07)	3,2 (7.05)	5,3 (11.68)	6,9 (15.21)	11,1 (24.47)	21,3 (46.95)	37,1 (81.79)	61 (134.48)

Specifications and Spare Parts

Series H / HW – DN 15 – 100 (1/2" - 4")

S-H(1)_en -Version 6– 18.06.2010

HR 2 + HWR 2, duoflow with rotating inner pipe, DN 15-100 (1/2" - 4")

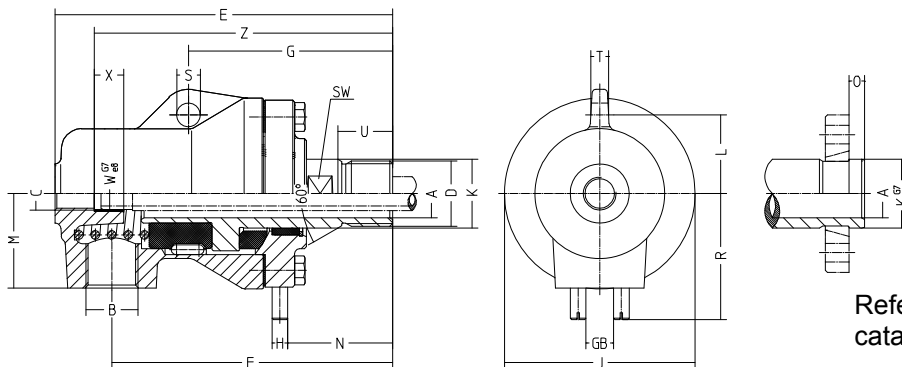

Refer to accessories catalog for flanges

DN mm DN inch △dim A	15 ½	20 ¾	25 1	32 1¼	40 1½	50 2	65 2½	80 3½	100 4
Type Best.-Nr	HR 215 R 1108056	HR 220 R 1108136	HR 225 R 1108219	HR 232 R 1108359	HR 240 R 1108459	HR 250 R 1108556	HR 265 R 1108657	HR 280 R 1108756	HR 2100 R 1108856
Type Best.-Nr	HR 215 L 1108057	HR 220 L 1108137	HR 225 L 1108220	HR 232 L 1108360	HR 240 L 1108460	HR 250 L 1108557	HR 265 L 1108658	HR 280 L 1108757	HR 2100 L 1108857
Type Best.-Nr	HR 215 K 1108058	HR 220 K 1108138	HR 225 K 1108224	HR 232 K 1108375	HR 240 K 1108463	HR 250 K 1108560	HR 265 K 1108659	HR 280 K 1108761	HR 2100 K 1108861
Type Best.-Nr	HWR 215 R 1108071	HWR 220 R 1108151	HWR 225 R 1108171	HWR 232 R 1108369	HWR 240 R 1108471	HWR 250 R 1108571	HWR 265 R 1108671	HWR 280 R 1108771	HWR 2100 R 1108871
Type Best.-Nr	HWR 215 L 1108072	HWR 220 L 1108152	HWR 225 L 1108172	HWR 232 L 1108370	HWR 240 L 1108472	HWR 250 L 1108572	HWR 265 L 1108672	HWR 280 L 1108772	HWR 2100 L 1108872
Type Best.-Nr	HWR 215 K 1108073	HWR 220 K 1108153	HWR 225 K 1108176	HWR 232 K 1108376	HWR 240 K 1108476	HWR 250 K 1108573	HWR 265 K 1108673	HWR 280 K 1108773	HWR 2100 K 1108873

Ø A	13	20	24,5	32	38	50	66	81	98
B	G 3/8	G ½	G ¾	G 1	G 1¼	G 1½	G 2	G 2½	G 3
C	G 1/8	G ¼	G 3/8	G ½	G ¾	G 1	G 1½	G 1½	G 2
D	G ½ A	G ¾ A	G 1 A	G 1¼ A	G 1½ A	G 2 A	G 2½ A	G 3½ A	G 4 A
E	128	144	172	200	223	272	324	393	475
F	107	120	143	167	183	225	264	320	383
G	85	91	104	118	124	146	165	203	243
H	6	6	8	8	10	16	18	18	25
Ø J	80	88	97	114	124	144	182	220	260
Ø K	25	30	35	45	52	66	85	107	118
Ø K G7/h8	24	30	35	45	50	65	85	105	114
L	31	36	40	48	53	62	80	100	115
M	34	42	48	55	65	80	90	115	135
N	44	49	53	63	66	81	93	121	143
O	6	8	8	8	10	10	10	12	12
R	52	56	64	74	82	92	115	135	168
S	12	12	12	16	16	18	20	22	26
T	7	8	9	10	12	13	15	20	22
U	23	23	28	33	36	43	48	54	66
Ø W G7/e8	10	12	16	20	25	31,8	45	45	60
X	15	15	15	15	25	25	30	30	40
Z	115	127	152	170	198	237	284	343	425
GB	12	12	14	16	16	18	20	22	26
SW	22	27	30	41	46	60	75	95	110
Weight kg (lbs)	1,6 (3.52)	2,3 (5.07)	3,2 (7.05)	5,3 (11.68)	6,9 (15.21)	11,1 (24.47)	21,3 (46.95)	37,1 (81.79)	61 (134.48)

Specifications and Spare Parts

Series H / HW – DN 15 – 100 (1/2" - 4")

S-H(1)_en -Version 6– 18.06.2010

H 3 + HW 3, duoflow with rotating inner pipe and vacuum valve, DN 25-40 (1" – 1½")

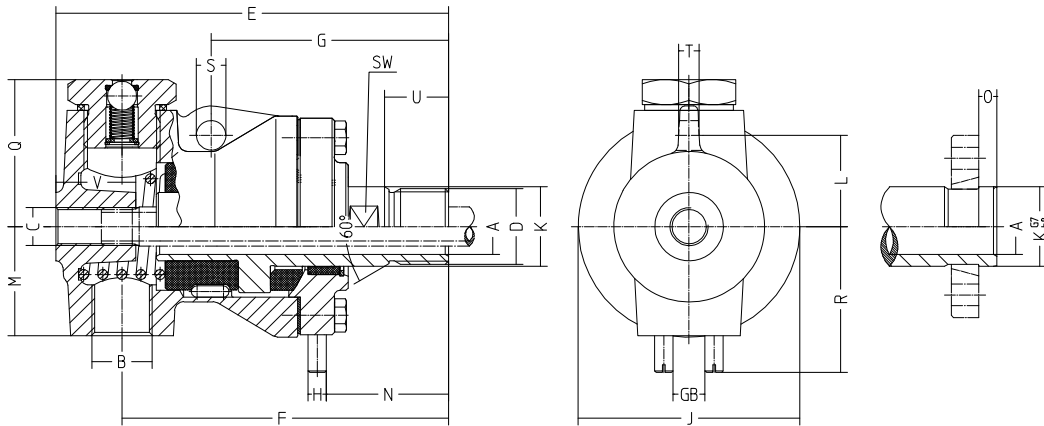

Refer to accessories
catalog for flanges

DN mm DN inch Δ dim A	25 1	32 1¼	40 1½
Type	H 325 R	H 332 R	H 340 R
Ordering no.	1108216	1108356	1108456
Type	H 325 L	H 332 L	H 340 L
Ordering no.	1108217	1108357	1108457
Type	H 325 K	H 332 K	H 340 K
Ordering no.	1108218	1108358	1108458
Type	HW 325 R	HW 332 R	HW 340 R
Ordering no.	1108173	1108371	1108473
Type	HW 325 L	HW 332 L	HW 340 L
Ordering no.	1108174	1108372	1108474
Type	HW 325 K	HW 332 K	HW 340 K
Ordering no.	1108175	1108373	1108475

Ø A	24,5	32	38
B	G ¾	G 1	G 1¼
C	G 3/8	G ½	G ¾
D	G 1 A	G 1¼ A	G 1½ A
E	172	200	223
F	143	167	183
G	104	118	124
H	8	8	10
Ø J	97	114	124
Ø K	35	45	52
Ø K G7/h8	35	45	50
L	40	48	53
M	48	55	65
N	53	63	66
O	8	8	10
Q	64,5	69	74
R	64	74	82
S	13	16	16
T	9	10	12
U	28	33	36
V	35	45	50
GB	14	16	16
SW	30	41	46
Weight kg (lbs)	3,6 (7.93)	5,7 (12.56)	7,3 (16.09)

Specifications and Spare Parts

Series H / HW – DN 15 – 100 (1/2" - 4")

S-H(1)_en -Version 6– 18.06.2010

HW 1 Series -450, monoflow, rotor material 1.4571 (SS 316 Ti), DN 15-25 (1/2" – 1")

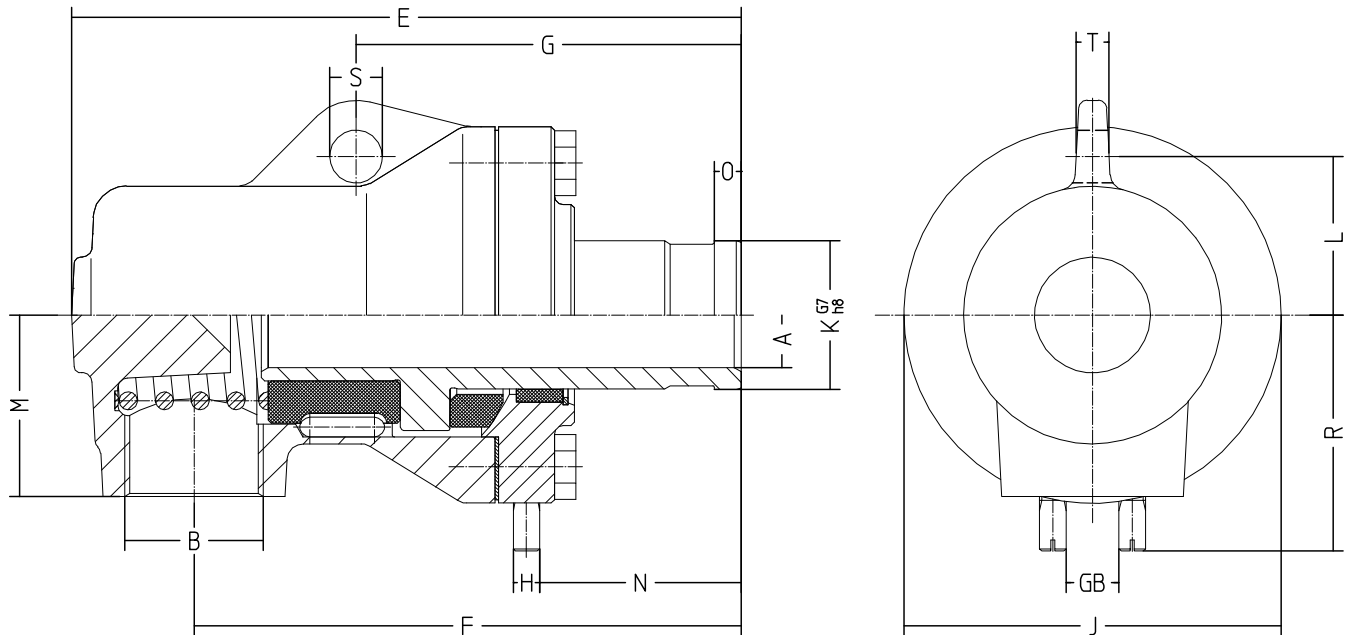

DN mm DN inch \triangle dim A	15 1/2	20 3/4	25 1
Type	HW 115 K-450	HW 120 K-450	HW 125 K-450
Ordering no.	1108067-450	1108147-450	1108169-450
\varnothing A	13	20	24,5
B	G 1/2	G 3/4	G 1
E	130	146	174
F	107	120	143
G	85	91	104
H	6	6	8
\varnothing J	80	88	97
\varnothing K G7 / h8	24	30	35
L	31	36	40
M	34	42	48
N	44	49	53
O	6	8	8
R	52	56	64
\varnothing S	12	12	12
T	7	8	9
GB	12	12	14
Weight kg (lbs)	1,7 (3.74)	2,4 (5.29)	3,4 (7.49)

Specifications and Spare Parts

Series H / HW – DN 15 – 100 (1/2" - 4")

S-H(1)_en -Version 6– 18.06.2010

HW 1 Series -500, monoflow, rotor material 1.4571 (SS 316 Ti), DN 32-100 (1¼" – 4")

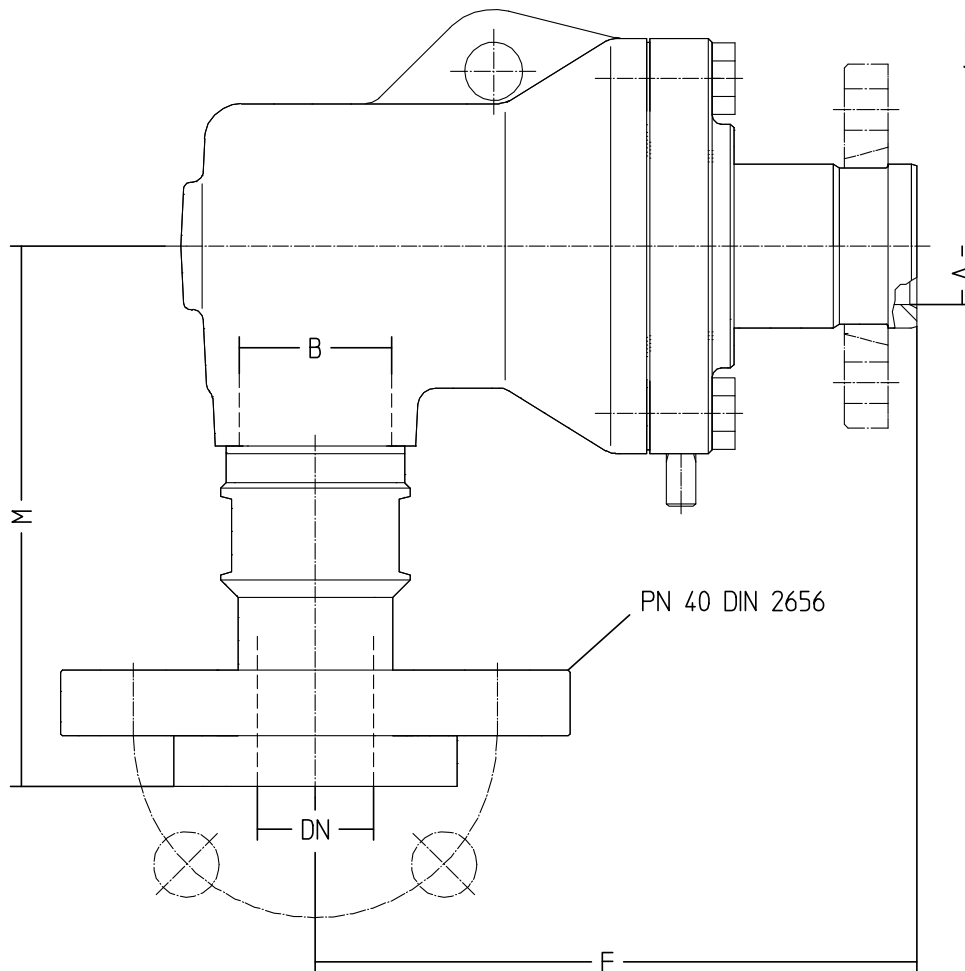

Refer to accessories catalog for flanges

PN 40 DIN 2656

DN mm DN inch Δ dim A	32 1¼	40 1½	50 2	65 2½	80 3½	100 4
Type	HW 132 K-500	HW 140 K-500	HW 150 K-500	HW 165 K-500	HW 180 K-500	HW 1100 K-500
Ordering no.	1108368-500	1108467-500	1108567-500	1108667-500	1108767-500	1108867-500
\varnothing A	32	38	50	66	81	98
B	G 1 ¼	G 1 1/2	G 2	G 2 1/2	G 3	G 4
F	167	183	225	264	320	383
M	148,5	160,5	179	193	239,5	277
DN	32	40	50	65	80	100
Weight kg (lbs)	8,5 (18.73)	10,5 (23.14)	16 (35.27)	27 (59.52)	46 (101.41)	74 (163.14)

All other dimensions can be found on page P7.

Specifications and Spare Parts

Series H / HW – DN 15 – 100 (1/2" - 4")

S-H(1)_en -Version 6– 18.06.2010

HW 2 + HWR 2 Series -450, duo flow, rotor material 1.4571 (SS 316 Ti), DN 20+25 (3/4" + 1")

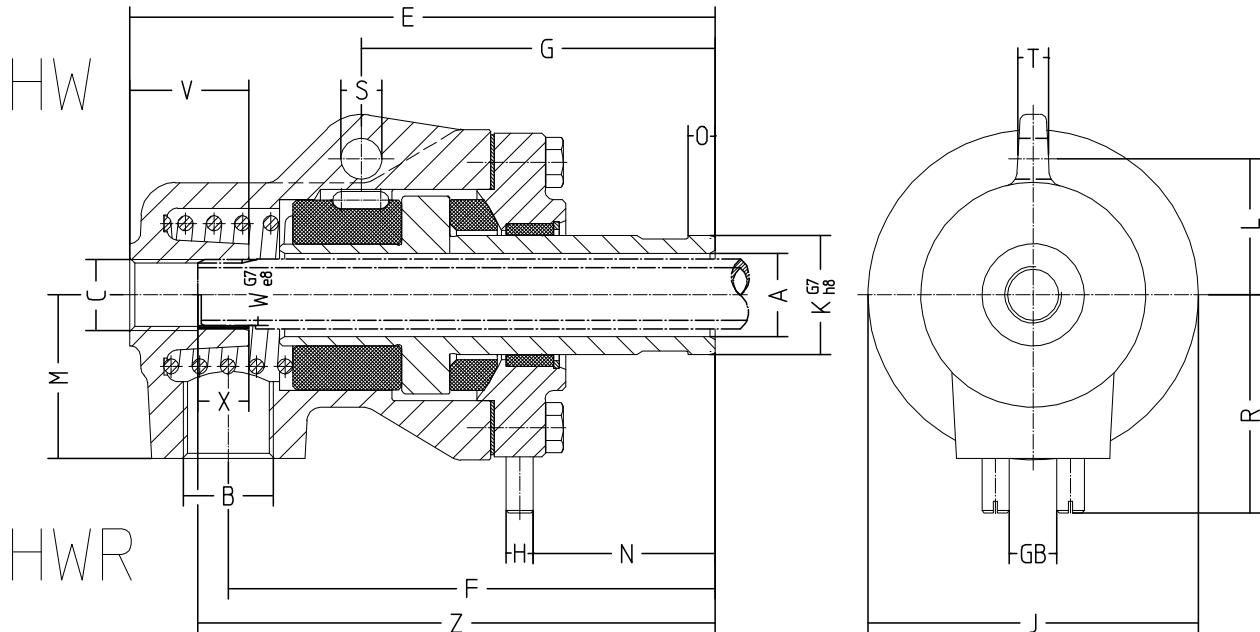

DN mm DN inch \triangle dim A	20 3/4	25 1
Type	HW 220 K-450	HW 225 K-450
Ordering no.	1108150-450	1108170-450
Type	HWR 220 K-450	HWR 225 K-450
Ordering no.	1108153-450	1108176-450

\varnothing A	20	24,5
B	G 1/2	G 3/4
C	G 3/8	G 1/2
E	144	172
F	120	143
G	91	104
H	6	8
\varnothing J	88	97
\varnothing K G7 / h8	30	35
L	36	40
M	42	48
N	49	53
O	8	8
R	56	64
\varnothing S	12	12
T	8	9
V	32	35
\varnothing W G7/e8	16	18
X	15	15
Z	127	152
GB	12	14
Weight kg (Isb)	2,3 (5.07)	3,2 (7.05)

Specifications and Spare Parts

Series H / HW – DN 15 – 100 (1/2" - 4")

S-H(1)_en -Version 6– 18.06.2010

HWX 2, duoflow, stationary inner pipe, DN 32-100 (1/4" – 4")

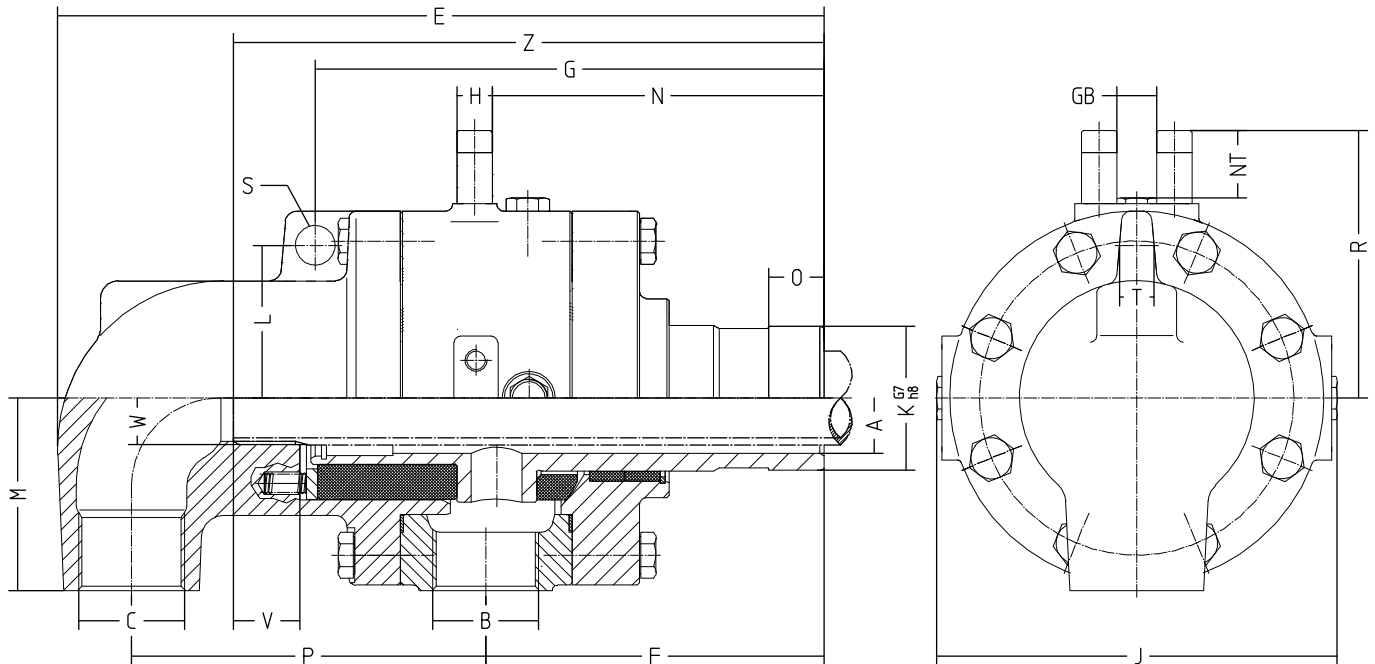

DN mm DN inch Δ dim A	32 1/4	40 1/2	50 2	65 2 1/2	75 3	80 3 1/2	100 4
Type	HWX 232 K	HWX 240 K	HWX 250 K	HWX 265 K	HWX 275 K	HWX 280 K	HWX 2100 K
Ordering no.	1108385	1108485	1108585	1108685	1108705	1108785	1108885

\varnothing A	32	38	50	66	67	80	98
B	G 1	G 1 1/4	G 1 1/2	G 2	G 2 1/2	G 2 1/2	G 3
C	G 1	G 1 1/4	G 1 1/2	G 2	G 2 1/2	G 2 1/2	G 3
E	271	313	347	402	535	540	609
F	120	132	153	178	270	275	305
G	183	204,5	230	272	380	385	424
H	13,5	16	16	18	18	18	25
J	150	159	181	218	274	274	302
\varnothing K G7 / h8	45	50	65	85	87,29	105	114
L	55	58	69	85	106	106	120
M	70	75	87	103	130	130	145
N	118	129	150	179	267	272	299
O	15	20	25	25	22,2	30	30
P	125	151	160	180	210	210	240
R	98	110	121	144	172	172	194
\varnothing S	16	16	18	20	22	22	26
T	13	15	16	18	25	25	26
V	25	30	30	30	25	30	30
W	G 3/4	G 1	G 1 1/4	G 1 1/2	G 1 1/2	G 2	G 2 1/2
Z	206	230	267	307	416	426	472
GB	16	16	18	20	22	22	26
NT	23	30,5	30,5	35	35	35	43
Weight kg (lbs)	12 (26.45)	16,5 (36.37)	22 (48.5)	37 (81.57)	73 (160.93)	73 (160.93)	92 (202.82)

Specifications and Spare Parts

Series H / HW – DN 15 – 100 (1/2" - 4")

S-H(1)_en -Version 6– 18.06.2010

HWB 2, duoflow, rotating inner pipe, DN 32-100 (1/4" – 4")

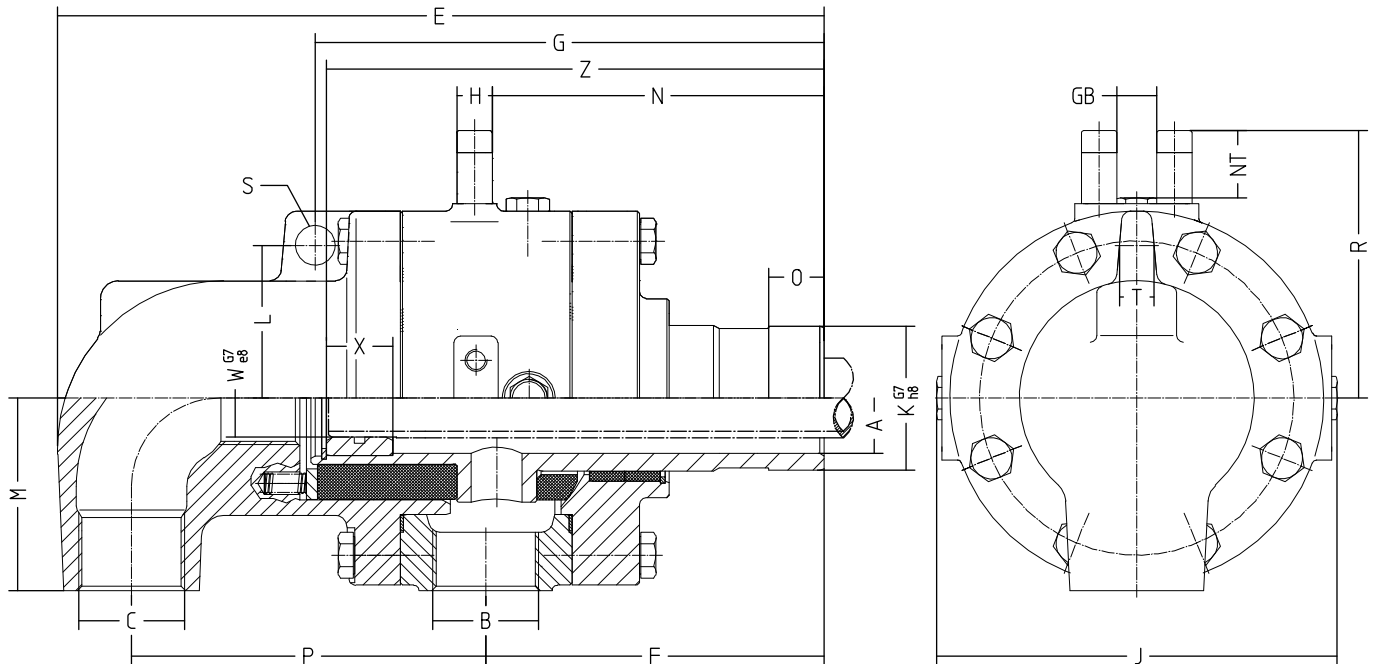

DN mm DN inch \triangle dim A	32 1 1/4	40 1 1/2	50 2	65 2 1/2	75 3	80 3 1/2	100 4
Type	HWB 232 K	HWB 240 K	HWB 250 K	HWB 265 K	HWB 275 K	HWB 280 K	HWB 2100 K
Ordering no.	1108402	1108482	1108577	1108677	1108702	1108778	1108902

\varnothing A	32	38	50	66	67	80	98
B	G 1	G 1 1/4	G 1 1/2	G 2	G 2 1/2	G 2 1/2	G 3
C	G 1	G 1 1/4	G 1 1/2	G 2	G 2 1/2	G 2 1/2	G 3
E	271	313	347	402	535	540	609
F	120	132	153	178	270	275	305
G	183	204,5	230	272	380	385	424
H	13,5	16	16	18	18	18	25
J	150	159	181	218	274	274	302
\varnothing K G7 / h8	45	50	65	85	87,29	105	114
L	55	58	69	85	106	106	120
M	70	75	87	103	130	130	145
N	118	129	150	179	267	272	299
O	15	20	25	25	22,2	30	30
P	125	151	160	180	210	210	240
R	98	110	121	144	172	172	194
\varnothing S	16	16	18	20	22	22	26
T	13	15	16	18	25	25	26
\varnothing W G7/e8	22	28	35	45	45	60	75
X	30	30	30	40	40	40	50
Z	172	190	225	260	372	377	419
GB	16	16	18	20	22	22	26
NT	23	30,5	30,5	35	35	35	43
Weight kg (lbs)	12 (26.45)	16,5 (36.37)	22 (48.5)	37 (81.57)	73 (160.93)	73 (160.93)	92 (202.82)

Specifications and Spare Parts

Series H / HW – DN 15 – 100 (1/2" - 4")

S-H(1)_en -Version 6– 18.06.2010

HWA 2, duoflow, rotating inner pipe, DN 32-100 (1/4" – 4")

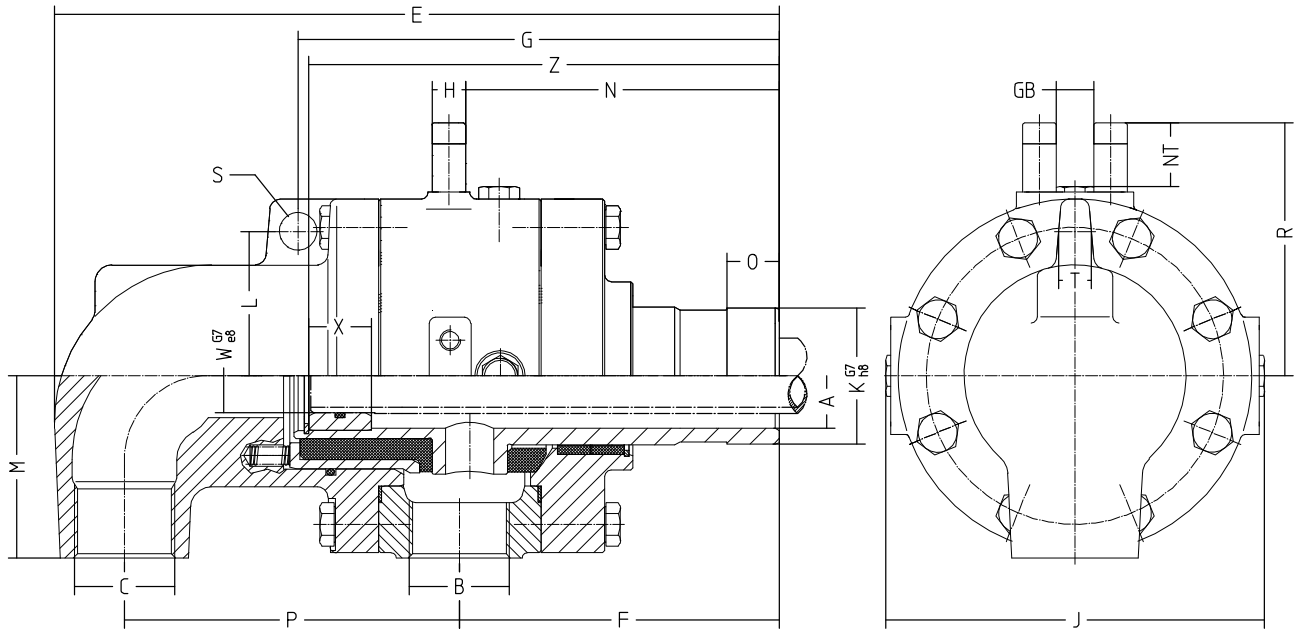

DN mm DN inch Δ dim A	32 1/4	40 1 1/2	50 2	65 2 1/2	75 3	80 3 1/2	100 4
Type	HWA 232 K	HWA 240 K	HWA 250 K	HWA 265 K	HWA 275 K	HWA 280 K	HWA 2099 K
Ordering no.	1108390	1108490	1108590	1108690	1108710	1108790	1108880

\varnothing A	32	38	50	66	67	80	98
B	G 1	G 1 1/4	G 1 1/2	G 2	G 2 1/2	G 2 1/2	G 3
C	G 1	G 1 1/4	G 1 1/2	G 2	G 2 1/2	G 2 1/2	G 3
E	271	313	347	402	535	540	609
F	120	132	153	178	270	275	305
G	183	204,5	230	272	380	385	424
H	13,5	16	16	18	18	18	25
J	150	159	181	218	274	274	302
\varnothing K G7 / h8	45	50	65	85	87,29	105	114
L	55	58	69	85	106	106	120
M	70	75	87	103	130	130	145
N	118	129	150	179	267	272	299
O	15	20	25	25	22,2	30	30
P	125	151	160	180	210	210	240
R	98	110	121	144	172	172	194
\varnothing S	16	16	18	20	22	22	26
T	13	15	16	18	25	25	26
\varnothing W G7/e8	22	28	35	45	45	60	75
X	30	30	30	40	40	40	50
Z	172	190	225	260	372	377	419
GB	16	16	18	20	22	22	26
NT	23	30,5	30,5	35	35	35	43
Weight kg (lbs)	12 (26.45)	16,5 (36.37)	22 (48.5)	37 (81.57)	73 (160.93)	73 (160.93)	92 (202.82)

Specifications and Spare Parts

Series H / HW – DN 15 – 100 (1/2" - 4")

S-H(1)_en -Version 6– 18.06.2010

HWX 2 + HWB 2 + HWA 2 Serie -500, duoflow, DN 32-100 (1¼" – 4")

Refer to accessories
catalog for flanges

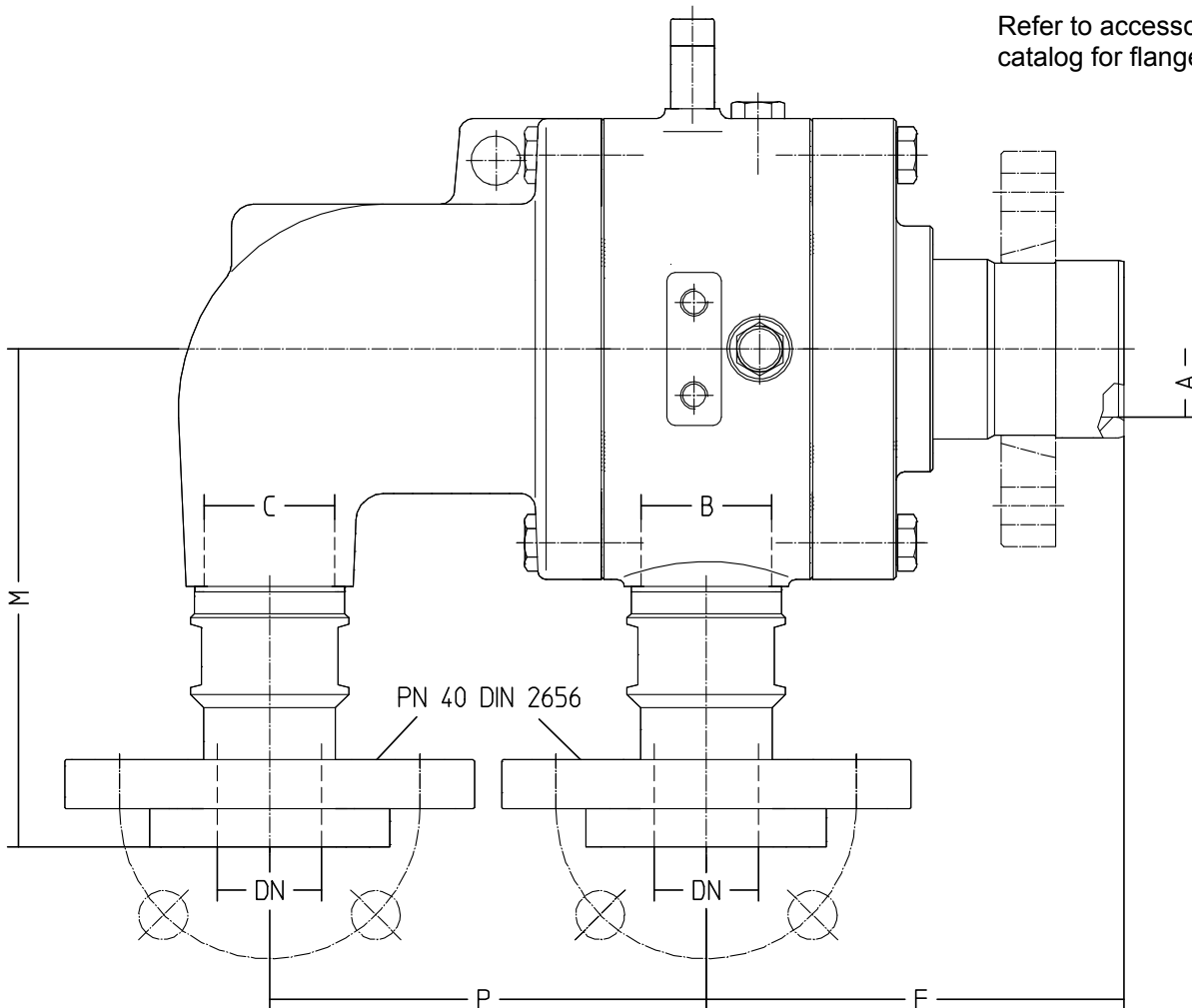

DN mm DN inch \triangle dim A	32 1¼	40 1½	50 2	65 2½	75 3	80 3½	100 4
Type Ordering no.	HWX 232 K-500 1108385-500	HWX 240 K-500 1108485-500	HWX 250 K-500 1108585-500	HWX 265 K-500 1108685-500	HWX 275 K-500 1108705-500	HWX 280 K-500 1108785-500	HWX 2100 K-500 1108885-500
Type Ordering no.	HWB 232 K-500 1108402-500	HWB 240 K-500 1108482-500	HWB 250 K-500 1108577-500	HWB 265 K-500 1108677-500	HWB 275 K-500 1108702-500	HWB 280 K-500 1108778-500	HWB 2100 K-500 1108902-500
Type Ordering no.	HWA 232 K-500 1108390-500	HWA 240 K-500 1108490-500	HWA 250 K-500 1108590-500	HWA 265 K-500 1108690-500	HWA 275 K-500 1108710-500	HWA 280 K-500 1108790-500	HWA 2099 K-500 1108880-500

Ø A	32	38	50	66	67	80	98
B	G 1	G 1 ¼	G 1 ½	G 2	G 2 ½	G 2 ½	G 3
C	G 1	G 1 ¼	G 1 ½	G 2	G 2 ½	G 2 ½	G 3
F	120	132	153	178	270	275	305
M	161,5	168,5	182,5	202	233	233	269,5
P	125	151	160	180	210	210	240
DN	25	32	40	50	65	65	80
Weight kg (lbs)	16 (35.27)	22 (48.50)	29 (63.93)	46,5 (102.51)	84,5 (186.29)	84,5 (186.29)	107 (235.89)

All other dimensions can be found on pages P14, P15 and P16.

Specifications and Spare Parts

Series H / HW – DN 15 – 100 (1/2" - 4")

S-H(1)_en -Version 6– 18.06.2010

Spare parts H 1 + HW 1, H 2 + HW 2, HR 2 + HWR 2, DN 15-100 (1/2" – 4"); H 3 + HW 3,
DN 25-40 (1" – 1 1/2")

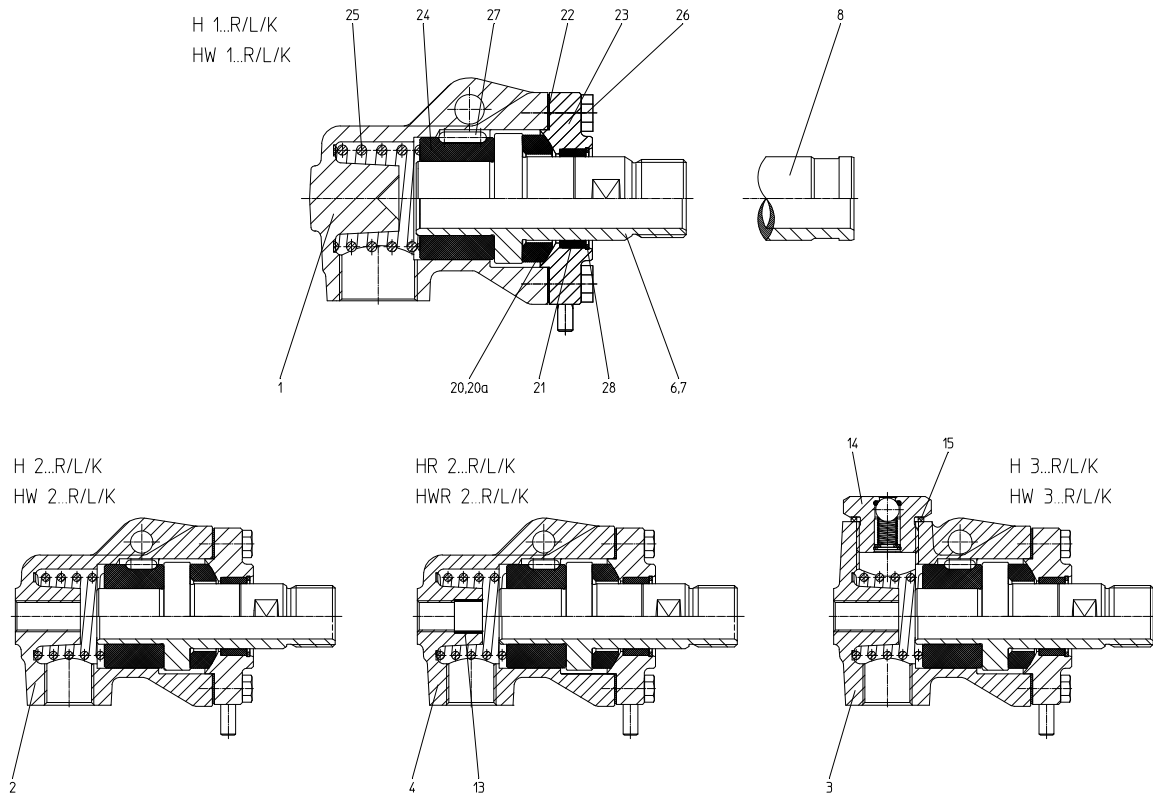

DN mm	15	20	25	32	40	50	65	80	100
DN inch Δ dim A	1/2	3/4	1	1 1/4	1 1/2	2	2 1/2	3 1/2	4
1 Housing 1	1103059	1103139	1103222	1103362	1103462	1103559	1103633	1103762	1103862
2 Housing 2	1103060	1103140	1103223	1103363	1103463	1103560	1103634	1103763	1103863
3 Housing 3	-	-	1103224	1103364	1103464	-	-	-	-
4 Housing R 2	1103061	1103141	1103225	1103365	1103465	1103561	1103649	1103765	1103865
6 Rotor R	1103063	1103143	1103227	1103367	1103467	1103563	1103643	1103767	1103867
7 Rotor L	1103064	1103144	1103228	1103368	1103468	1103564	1103644	1103768	1103868
8 Rotor K	1103065	1103145	1103229	1103369	1103469	1103565	1103637	1103769	1103869
13 Slide bearing	3510502	3510504	3510506	3510501	3510509	3510512	3510514	3510514	3510523
14 Vacuum valve	-	-	1190020	1190020	1190020	-	-	-	-
15 CU seals	-	-	3511962	3511962	3511962	-	-	-	-
20 Sealing ring	3511301	3511302	3511303	3511304	3511305	3511306	3511307	3511308	3511309
20a Sealing ring W	3510641	3510642	3510643	3510644	3510645	3510646	3510647	3510648	3510649
21 Cover bearing	3510601	3510602	3510603	3510604	3510605	3510606	3510607	3510608	3510609
22 Flat packing	3512001	3512002	3512003	3512004	3512005	3512006	3512007	3512016	3512017
23 Cover complete	1108059	1108139	1108221	1108361	1108461	1108559	1108653	1108759	1108858
24 Carbon bearing	3511341	3511342	3511343	3511344	3511345	3511346	3511347	3511348	3511349
25 Compression spring	3511616	3511617	3511618	3511619	3511620	3511621	3511622	3511626	3511627
26 Hex screw	3500087	3500087	3500087	3500125	3500125	3500165	3500163	3500163	3500197
27 Locking pin	3500932	3500932	3500932	3500933	3500933	3500934	3500934	3500934	3500934
28 Locking ring (circlip)	3500701	3500697	3500702	3500703	3500704	3500705	3500706	3500707	3500708

Please specify rotary joint type designation when inquiring and placing orders!
Repair as per separate instructions.

Specifications and Spare Parts

Series H / HW – DN 15 – 100 (1/2" - 4")

S-H(1)_en -Version 6– 18.06.2010

Spare parts HWX 2 / HWB 2 + HWA 2, DN 32-100 (1/4" – 4")

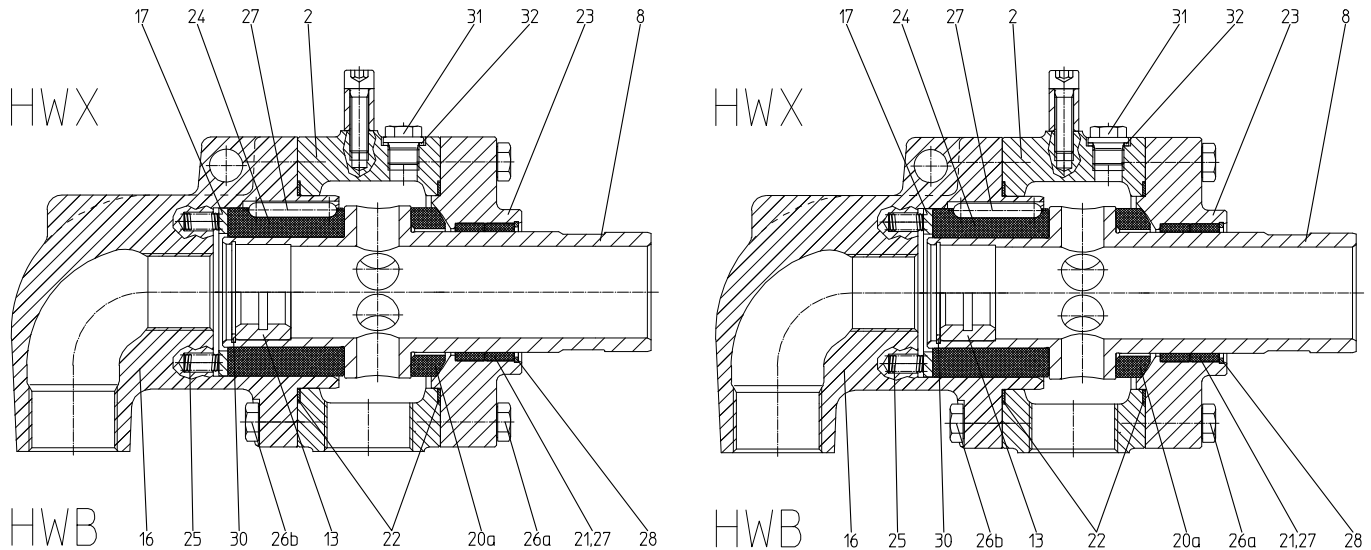

	DN mm DN inch Δ dim A	32 1 1/4	40 1 1/2	50 2	65 2 1/2	75 3	80 3 1/2	100 4
2	Housing	1103400	1103500	1103582	1103700	1103810	1103810	1103930
8	Rotor	1103404	1103504	1103587	1103704	1103752	1103814	1103934
13	Bushing	1103387-417	1103481-365	1103581-428	1103651-397	1103755-054	1103787-446	1103888-552
16	Elbow B2, X2	1103409	1103509	1103594	1103709	1103757	1103819	1103939
17a	Elbow A2	1103410	1103510	1103595	1103710	1103758	1103820	1103940
17	Trust washer	1103392-432	1103492-377	1103613-441	1103746-419	1103792-463	1103792-463	1103921-570
20a	Sealing ring W	3510644	3510645	3510646	3510647	3510648	3510648	3510649
21	Cover bearing	2x 3510604	2x 3510605	2x 3510606	2x 3510607	3511348	3511348	3511349
22	Flat packing	1114193-059	1103799-419	3512013	3512018	1110669-063	1110669-063	3512355-071
23	Cover complete	1103407	1103507	1103592	1103707	1103817	1103817	1103937
24	Carbon bear.B2, X2	3511344	3511345	3511346	3511347	3511348	3511348	3511349
24a	Carbon bearing A2	3511344-421	3511345-362	3511346-426	3511347-398	3511348-449	3511348-449	3511349-549
25	Compression spring	5x 3511668-001	6x 3511668-001	8x 3511668-001	4x 3511564	8x 3511564	8x 3511564	12x 3511564
26a	Hex screw 1	8x 3500123-008	8x 3500124-008	8x 3500166-008	8x 3500163	8x 3500197	8x 3500197	8x 3500197
26b	Hex screw 2	8x 3500125	8x 3500123-008	8x 3500165	8x 3500163	8x 3500197	8x 3500197	8x 3500197
27	Locking pin B2, X2	1x 3500933	1x 3500933	1x 3500934	1x 3500934	2x 3500934	2x 3500934	2x 3500934
27a	Locking pin 1 A2	3500951-001	3500933	3500889-001	3500961-001	3500961-001	3500961-001	3500934
27b	Locking pin 2 A2	---	---	---	---	3500934	3500934	3500934
28	Locking ring (circlip)	3500703	3500704	3500705	3500706	3501237-001	3501237-001	3501043
30	Locking ring (circlip)	3501234	3501225	3501232	3501236	3501205	3501205	3501251
31	Vent screw	3x 3500657	3x 3500658-007	3x 3500658-007	3x 3500655-007	3x 3500655-007	3x 3500655-007	3x 3500655-007
32	Sealing ring	3x 3502114-001	3x 3502116-001	3x 3502116-001	3x 3502115-001	3x 3502115-001	3x 3502115-001	3x 3502115-001
34	O-ring	3511701	3511708	3511694	3511692	3511702	3511702	3512515
35	O-ring	3511955	3511824	3511733	3511931	3511734	3511816	3511825

Please specify rotary joint type designation when inquiring and placing orders!
Repair as per separate instructions.

Repair Instructions

Series H/HW

R-h_en Rel. 01.10.2008

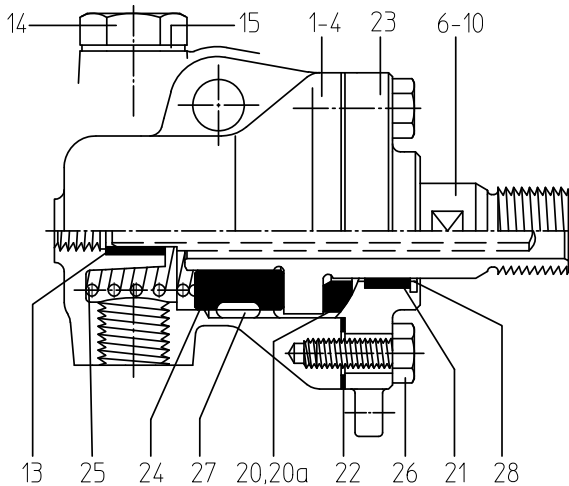

1 Housing 1	* 20a Sealing ring
2 Housing 2	* 21 Cover bearing
3 Housing 3	* 22 Flat packing
4 Housing R2	* 23 Complete cover
* 6 Rotor R	* 24 Carbon bearing bush
* 7 Rotor L	25 Pressure spring
* 8 Rotor K	26 Hex screw
* 13 Slide bearing	27 Locking pin
14 Vacuum valve	28 Locking ring
15 CU seal	29 O ring vacuum valve
* 20 Sealing ring	

* = wearing part

Repair

Repair is required during preventive maintenance or when leaks are detected between cover 23 and rotor 6-10.

Dismantling the unit

- Unscrew screws 26 at cover 23. **ATTENTION: The internal parts are under spring tension.** To slowly reduce the tension, use two threaded rods.
- Lift off cover 23. All internal parts can now be removed from housing 1-4. **Caution:** carbon bearing 24 may be difficult to remove!
- Remove cover bearing 21 from cover 23.
- Version for rotating inner pipe: remove slide bearing 13 from housing 4.
- Version H 3: unscrew vacuum valve 14 from housing.

Evaluating the parts

- The quality of the sealing surfaces of sealing ring 20/20a, rotor 6-10 and cover 23 is of particular importance. These parts are precision-turned. Therefore, always replace sealing ring 20/20a. Reuse rotor 6-10 and cover 23 only if turning of the sealing surface is still possible. Size DN 65 (2½") and greater: maximum turning tolerance at rotor is 1 mm (0.0393"). **ATTENTION!** If you detect scoring on the sealing surface of rotor 6-10 and cover 23, it is not sufficient to replace only the sealing ring 20/20a!
- Lap sealing ring 20/20a (rotor and cover 23 (fig. 2)), 2 mm (0.0787") wide. Use lapping paste (S). Then clean the parts with an agent which does not leave any residue.
- Replace cover bearing 21, flat packing 22, carbon bearing 24.
- Version H 3: check function of vacuum valve, replace, if necessary. Replace sealing ring 15 and O-ring 29.

Reassembling the unit

- Version with rotating inner pipe: press slide bearing 13 into housing 4.

- Place compression spring 25 into housing 1-4.
- Insert carbon bearing bush 24 and locking pin 27 into housing 1-4. The arrow must point towards the compression spring. Observe position of the groove in the housing (attention: danger of damage).
- Insert rotor 6-10 into housing 1-4.
- Fit sealing ring 20/20a onto rotor 6-10.
- Fit cover 23 and flat packing 22 onto housing and carefully tighten the cover by means of screws 26 (apply even torque).
- Function check apply axial load on the rotor to compress springs. If axial displacement of 2 - 3 mm (0.0787" - 0.118") is possible, the unit has been properly reassembled.
- Retighten screws 26 after a short operating period.
- Version H 3: screw vacuum valve 14 with CU sealing ring 15 into housing 3.

ATTENTION! Never oil or grease the sealing surfaces!

Spare parts

It is recommended to stock the wearing parts mentioned above. Always specify the part number and the complete type designation of the rotary joint as per data plate when ordering spare parts.

- We reserve the right to technical modifications -

Fig. 2: Lapping the sealing ring for H/HW

