



Operating Instructions for Maier Rotary Joints

Series DX / DXS





Preface	Keep this manual for future reference.
Editor	Christian Maier GmbH & Co. KG Maschinenfabrik Würzburger Str. 67-69 Postfach 16 09 D-89520 Heidenheim D-89506 Heidenheim Tel: +49 7321/317-0 Fax: +49 7321/317-139 E-Mail: ykd@maier-heidenheim.de Website: www.maier-heidenheim.de
Copyright	© Christian Maier GmbH & Co. KG Maschinenfabrik This manual including all parts of this manual is protected by international copyright laws. Any use or modification of this manual beyond the limits of the copyright laws is prohibited and a legal offense without the consent of Christian Maier GmbH & Co. KG Maschinenfabrik. This applies, but is not limited to reproduction, translation, microfilming and storing and processing in electronic systems.

Section	Contents	Designation
1	General part of the operating instructions	
2	Specifications and spare parts	

Document identification

Title: Operating Instructions for Maier Rotary Joints
Document designation: B-DX_en
Document type: Translation of the original
Date of issue: 07.2011
Version: 12

List of modifications

Version index	Comment	Date	Editor
10	1.edition Innovativ	04.2011	cma
11	Table 1 and table 3 changed	06.2011	cma
12	Table 3 text modification	07.2011	cma



B General part of the operating instructions for Maier Rotary Joints DX/DXS

Contents

1. General.....	2
1.1 Information on this manual.....	2
1.2 Explanation of symbols	2
2. Product description.....	3
2.1 Intended use	3
2.2 Reasonably foreseeable misuse.....	3
2.3 Components.....	4
2.4 Function	4
3. Safety	7
3.1 Introduction	7
3.2 General safety information.....	7
3.3 Structure of the safety instructions.....	8
3.3.1 Terms	8
3.3.2 Pictograms	9
3.4 Authorized staff.....	9
3.5 Risk assessment and residual risks.....	10
4. Transportation and storage	11
5. Information on design and mounting and operation	11
6. Mounting.....	13
6.1 Mounting the rotary joint to the roller	13
6.2 Connecting the rotary joint.....	18
7. Operation.....	21
7.1 Commissioning	21
7.2 During operation	21
7.3 Troubleshooting	22
8. Maintenance.....	23
8.1 Maintenance plan.....	23
8.2 Repair	23
8.2.1 Tools.....	23
8.2.2 Repair work	24



1. General

1.1 Information on this manual

This manual is intended for use by the operators, the maintenance and the inspection staff. It is divided into the following sections

- Section 1 "General Part of the Operating Instructions":
(pages with the designation B)
This section provides general information on the manual, on safety and on handling the product
- Section 2 "Specifications and Spare Parts":
(pages with the designation S)
This section provides product-specific data
- Section 3 "Additional information for use in hazardous areas (EX areas)":
(pages with the designation A)
(only available for products certified as per directive 94/9/EC)

The operators must read and fully understand this manual and observe all instructions it contains. Exclusion of liability: We shall not be responsible in any way for damages and interruptions or any type of consequences whatsoever resulting from the failure to read and/or observe the instructions contained in this manual.

Read chapter 3 and the specific safety instructions in the individual chapters with particular care.

We reserve the right to technical modifications, i.e. the components may actually differ from the information given in this manual to the extent to which such modifications are required to improve the rotary joint or its accessories.

1.2 Explanation of symbols

Symbol	Used for	Explanation
•	List	List of facts or instructions. No specific sequence required.
1.	Instructions consisting of several individual steps	Instructions consisting of several steps must be followed exactly in the sequence listed. Failure to observe the instructions in the correct sequence may result in damages or accidents.
[1]	Item number	Item number of the component mentioned in the corresponding illustration.



2. Product description

2.1 Intended use

Maier rotary joints are devices which may only be used to connect pressurized pipes to rotating pressurized systems. Typical examples of such rotating pressurized systems are rollers through the inside of which flow liquids or steam in order to heat or cool down the rollers. Series DX/DXS rotary joints are designed for water. Other fluids are possible; please contact the manufacturer. Please refer to the section "Specifications and Spare Parts" for approved fluids and their qualities and limits; this information must be observed in the application.

Never modify the rotary joint as this may cause hazards. Install, operate and maintain the rotary joint only as described in these operating instructions. We shall not be liable for any damage and interruption whatsoever caused by failure to adhere to the operating instructions.

Always comply with all national and local regulations applicable at the installation site as well as all regulations concerning the prevention of accidents.

Use only genuine Maier spare parts or Maier-approved standard norm parts for repairs. If you use other parts, this may have adverse effects on the safety of the unit.

2.2 Reasonably foreseeable misuse

In the case of reasonably foreseeable misuse of the product, the manufacturer's warranty shall be void and the operator shall be fully responsible for the consequences.

Reasonably foreseeable misuse includes:

- failure to adhere to application data
- failure to adhere to fluid specifications
- failure to adhere to maintenance intervals
- failure to replace wearing parts
- failure to perform maintenance work
- maintenance work performed with errors
- additional components mounted and conversions without written approval
- use of spare parts other than genuine spare parts

B Operating Instructions for Rotary Joints Series DX/DXS

2. Product description

2.3 Components

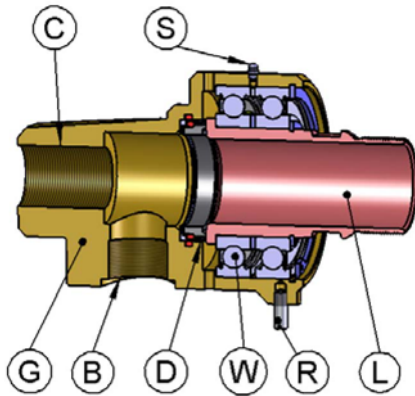

B-1

B, C Housing connections for the fluid.
Only one housing connection in the case of mono-flow (single-passage) version.

D Rotating mechanical seal

G Housing (stationary)

L Rotor (rotating)

R Locking of housing

S Lubricant inlet

W

Roller bearing

2.4 Function

Maier rotary joints are devices which allow you to connect stationary pressurized pipes to rotating pressurized systems. Typical examples of such rotating pressurized systems are rollers through the inside of which flow liquids, gases or steam, for example in order to heat or cool down the rollers.

The connection to the stationary pressure system (housing connection) is obtained via the stationary part of the rotary joint – the housing. Depending on the version of the rotary joints, the following types can be distinguished:

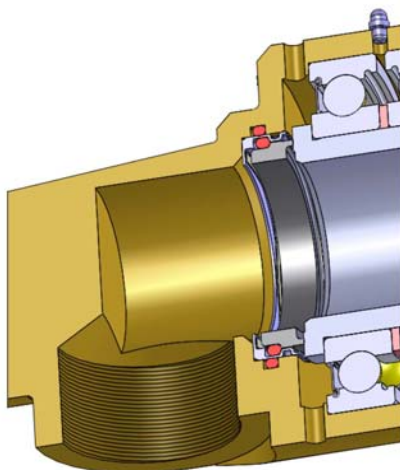

B-2

- **Mono versions (single-passage) (DX 1/DXS 1):** housing with one connection for supplying or removing the fluid to or from the rotating pressure system.

B Operating Instructions for Rotary Joints Series DX/DXS

2. Product description

- **Duo versions (dual passage):** housing with two connections for supplying and removing the fluid to and from the rotating pressure system. The second flow channel is formed by an inner pipe that is centered in the center axis of the rotating part. The design of the inner pipe differs in terms of the following versions:

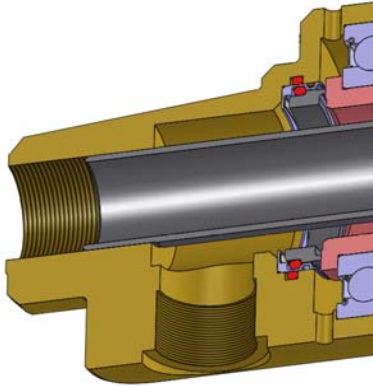

B-3

- **Stationary inner pipe (DX 2/DXS 2):** The inner pipe is screwed into the housing (standard version always with right-hand thread).

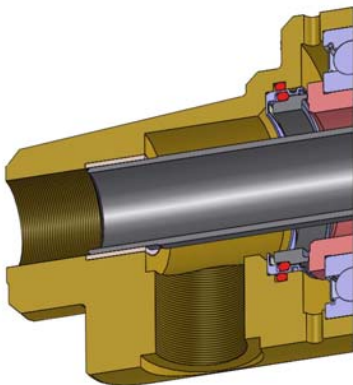

B-4

- **Rotating inner pipe supported in the housing (DXR 2/DXSR 2):** the inner pipe is supported by a self-lubricating slide bearing in the stationary housing. There is wear at the bearing point.

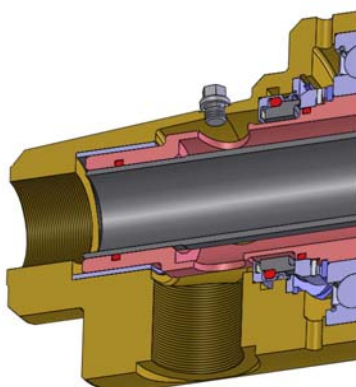

B-5

- **Rotating inner pipe for static support in the rotating part of the rotary joint (DXB 2/DXS B2):** The inner pipe is held by a guide hole in the rotor. There is no wear at the bearing point.

B Operating Instructions for Rotary Joints Series DX/DXS

2. Product description

The connection to the rotating pressure system (rotor connection) is made by the rotating part of the rotary joint – the rotor. Depending on the version, the following types can be distinguished:

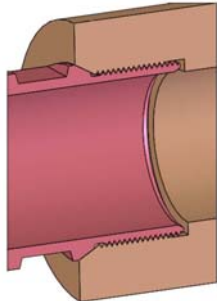

B-6

or

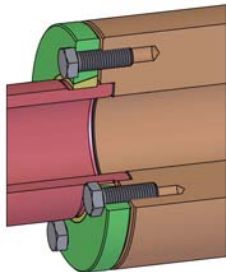

B-7

- **Threaded version:**
Connection at rotor by means of right-handed or left-handed thread (R/L).
The system is sealed by means of a sealing cone.

- **Flange version**

Connection at rotor by means of K flange (K).

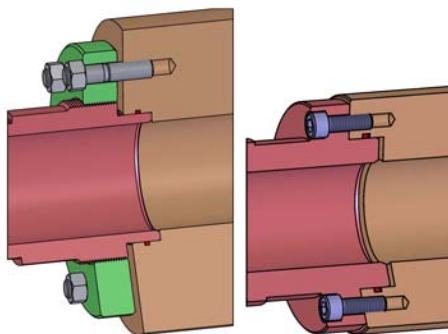

B-8

Connection at rotor by means of screw flange or fixed flange (F).

The system is sealed by means of a flat packing or an O ring.

INFORMATION



Please refer to our catalog and the corresponding outline drawing in the section "Specifications and Spare Parts" for further information.

3. Safety

3.1 Introduction

The rotary joint was designed and built according to the latest technology and complies with the pertinent safety regulations. However, the rotary joint may still cause dangers if it is not used as intended and according to the instructions or if it is used by untrained staff or if it is tampered with in any way.

Never tamper with the rotary joint or modify it in any way as this may adversely affect the safety and the performance of the rotary joint. We shall not be liable for any damages resulting from unauthorized modification of the rotary joint.

We strongly advise the owner/operator of the rotary joint to check his safety concept in terms of the effects a failure of the rotary joint may have on the environment. Make sure to take all additional safety measures required to protect persons and the environment.

3.2 General safety information

- Always keep the operating instructions at the installation site for quick and easy access.
- In addition to the instructions provided in this manual, you must also observe all the pertinent regulations and guidelines concerning workplace safety and prevention of accidents.
- Provide a sufficient torque support for the rotary joint.
- Use only flexible elements for housing connections. Do not apply forces to the housing via the connections.
- Only perform work on the rotary joint when the machine/system is at a standstill and the pressure released.
- Only operate the rotary joint if it is in perfect technical condition. Only use the rotary joint according to the instructions and specifications; never operate the unit outside of the framework of the specifications and performance data indicated. Be aware of all pertinent safety and danger aspects when operating the rotary joint. Immediately repair any malfunctions or problems or have such malfunctions or problems repaired as they may interfere with the safety of the rotary joint!
- The service life of counter-rotating parts is limited. Therefore, perform preventive maintenance of seals and bearings after no more than 12 months!
- If you need to dismantle safety devices for repair or maintenance of the rotary joint, you must refit such devices immediately upon completion of the work and check the proper function of the devices!
- When replacing the rotary joint, carefully fasten it to appropriate lifting gear and secure it in such a way that it cannot cause danger. Use only suitable lifting gear which is in perfect technical condition and which has a sufficient rating for the load to be lifted! Never step or work below suspended loads!
- Retighten all screw connections that you may have loosened for maintenance or repair work! Refer to the section "Specifications and Spare Parts" for information on the tightening torques.
- Use only genuine spare parts for repairs.

INFORMATION



Refer to the section "Specifications and Spare Parts" for additional information.

3.3 Structure of the safety instructions

3.3.1 Terms

 **DANGER**



Immediately imminent danger. Failure to observe the information will result in death or severe injuries.

 **WARNING**



Possibly imminent danger! Failure to observe the information can result in death or severe injuries.

 **CAUTION!**



Possibly imminent danger! Failure to observe the information may result in minor injuries.

NOTE

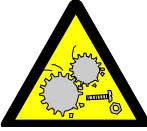

Possibly imminent danger! Failure to observe the information may result in damage to property.

INFORMATION



Provides additional information



3.3.2 Pictograms



Warning: general hazards

This warning pictogram highlights activities that involve several hazards.



Warning: hot surfaces

This warning pictogram highlights activities that involve hazards caused by hot surfaces.



Warning: crushing hazard

This warning pictogram highlights activities that involve hazards caused by rotating machine parts.

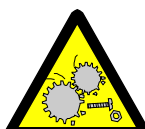

Warning: equipment damages

This warning pictogram highlights activities that involve damage to the rotary joints caused by incorrect operation.

3.4 Authorized staff

Only staff that has read and fully understood these operating instructions and that is fully aware of the dangers resulting from the unit as well as the appropriate safety precautions may work with Maier rotary joints. Such staff must have at least the knowledge of a trained locksmith or industrial mechanic who has experience with pressurized components.

Each person having to do with the installation, mounting, dismantling, commissioning, maintenance and repair of the rotary joint or any other activities concerning the rotary joint must have read and fully understood the operating instructions (and, in particular, all the safety information) before taking up such activities. It is recommended that the owner of the rotary joint have each person confirm this in writing.



3.5 Risk assessment and residual risks

Rotary joints are machine components that can be used in a large variety of machines and system. These products are not subject to the Machinery Directive 2006/42/EC – hazards caused by this product are treated by compliance with the pertinent directive 97/23/EC (Pressure Equipment Directive). Directive 94/9/EC (Explosion Protection Directive) additionally applies to "ATEX" certified rotary joints.

After installation of our rotary joints into systems/machines, these are subject to the Machinery Directive and may be subject to additional directives and legislation. The user of our products is responsible for complying with all pertinent directives and legislation as well as for performing a risk assessment in accordance with these directives. Depending on the actual installation situation and the actual use of our product, risks may arise that should be avoided by design measures, if possible.

An analysis carried out by Christian Maier GmbH & Co. KG Maschinenfabrik resulted in the aspects listed below which necessitate an additional risk assessment by the user after installation of our products in the system/machine:

- If hot parts are touched or if hot or hazardous fluids escape under high pressure or if rotating parts draw in persons, this may result in severe burns, cuts or crushing.
 - Possible measures: Mount a protective cover to the rotary joint that prevents direct contact with hot parts, safely retains escaping fluid and avoids contact with rotating parts.
 - If a hood cannot be mounted, other suitable protective measures must be taken. Always use the housing connections provided for the safe discharge of leaking fluid.
- If the rotary joint blocks and rotates along with the roller, hoses can be torn off and hot or hazardous fluids may escape under high pressure.
 - Always observe the design and mounting and operation information in chapter 5.
 - In particular in the case of greater nominal diameters in connection with higher speeds and temperatures, it is recommended to monitor the rotary joint by means of a torque monitoring system – alternatively by means of a vibration sensor.
 - Ensure that the unit is regularly maintained as per chapter 7.

The user of our products must verify the applicability and effectiveness of the possible measures listed in the actual situation.



4. Transportation and storage

Transportation

- Use suitable lifting gear to transport rotary joints weighing more than 25 kg.

Storage

- In the original packages, Maier rotary joints are not suited for a storage time of more than 6 months.
- In the case of extended shutdown or storage periods of rotary joints, it is recommended to use suitable corrosion protection film as provided, for example, by Cortec Corp. (www.CortecVCI.com).
- The storage room must be free from dust, sufficiently ventilated and not subject to major temperature changes (relative humidity below 65%, temperature between 15°C and 30°C).
- After a storage time of more than 2 years or when the package has been damaged or the unit has been subjected to shocks, the rotary joint must be checked in the factory or the nearest service center!
- If you want to preserve complete system components including the rotary joint, make sure the corrosion protection measures are compatible with the materials and sealing elements used. Risk of chemical reactions and accumulations at sealing and bearing elements.

5. Information on design and mounting and operation

The following must be noted for fast and reliable mounting and commissioning, for safe operation of the rotary joint and for ensuring that the warranty will not be void:

- Never operate the rotary joint outside of the application and performance limits specified.
- For smooth operation of rotary joint ensure concentricity and minimum run-out tolerance of roller and intermediate flange!
- The information on the admissible mounting position of the rotary joint provided in the section "Specifications and Spare Parts" must be adhered to.
- For the connection, use flexible hoses between the supply system and the rotary joint housing. This compensates for heat expansion and vibrations.
- Never apply torsional, tensile or pressure loads to metal hoses. Observe the minimum bending radius as specified by the manufacturer – if in doubt, contact your hose vendor. Section 6.2 provides examples of possible hose installation. Never use axial compensators.
- Use flat packings made of pure graphite to securely seal flange connections.
- Only operate the rotary joint with a sufficiently dimensioned torque support at the housing. Use a locking pin or an anti-rotation fork. The support element must allow for axial and radial movements of the housing.

B Operating Instructions for Rotary Joints Series DX/DXS

5. Information on design and mounting and operation

- Install an additional safety unit:
Install a torque monitoring system or a bearing monitoring system with vibration pickup (e.g. FAG or SKF) with connection to the emergency shutdown system in order to avoid bearing damage and consequential damage.
Refer to the section "Specifications and Spare Parts" for limit values concerning the admissible friction torque. Section 6.2 provides an example of the possible anti-rotation design of the housing.
If the monitoring system is activated, the rotation of the roller should be stopped immediately and the supply of the fluid should be interrupted upstream of the metal hoses.
- Center the inner pipe and the roller as well as the rotary joint. Run-out and axial tension of the inner pipe will lead to malfunctions of the rotary joint.
- In the case of greater nominal diameters of the rotary joint, long inner pipes or high speeds, it is recommended to separate the inner pipe in the area of the rotor connection. Section 6.1 provides an example of the possible design. This facilitates mounting of the rotary joint and, in the case of DXR 2/DXSR 2 rotary joints, reduces the wear and tear at the bearing bushing for the inner pipe.
- In the case of a rotary joint with rotating inner pipe, version DXR 2/DXSR 2, it is recommended to use a stainless steel inner pipe or at least a hard chromium-plated bearing seat.
- Operation with water exceeding 70°C:
In order to ensure maximum reliability and service life of the seal in the rotary joint, the hot water used in the rotary joint must be processed, treated and conditioned according to the VdTÜV Guidelines Technical Chemistry 1466 (VdTÜV - Merkblatt Technische Chemie 1466). The circulated water must have a low salt concentration and a maximum conductivity of < 100 µS/cm! If the water contains salt, this may result in deposits in the seal gap and premature failure of the seal.

For ATEX-certified products (directive 94/9/EC)

- Check the resistance between the rotary joint and the system, if necessary, use equipotential bonding conductors.
- Determine the maximum temperature of the system, if necessary, install a safety thermostat.

INFORMATION



Refer to section 3.4 for additional information.

6. Mounting

6.1 Mounting the rotary joint to the roller

INFORMATION



When using a flat packing, use pure graphite with metal insert.

Mounting preparation and separation of inner pipe for duo (dual-passage) version

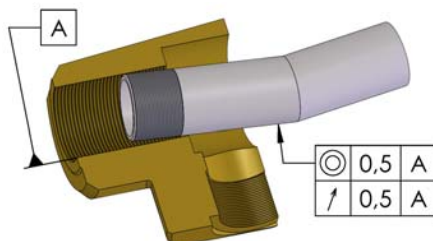

B-9

- With stationary inner pipe (DX 2/DXS 2):
Screw inner pipe [J] into housing. Make sure the inner pipe and the axis of rotation are centered.

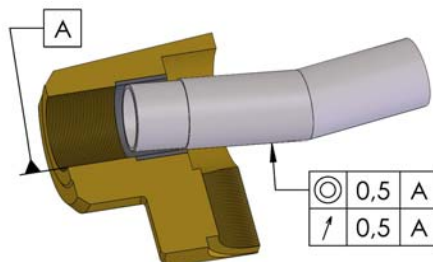

B-10

- With rotating inner pipe (DXR 2/DXSR 2):
Mount inner pipe [J] into the rotating roller. Make sure that the bearing surface of the inner pipe is centered in the slide bearing and that there is no tension.
- With rotating inner pipe (DXSB 2):
Insert inner pipe [J] into rotor, do not damage the O ring in the rotor when doing so!

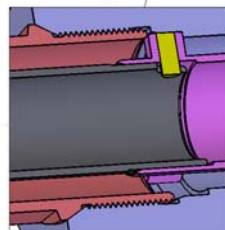
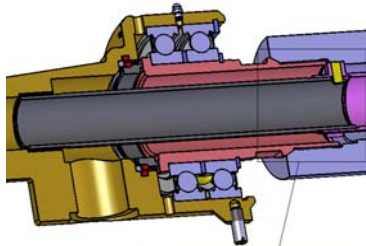

B-11

- In the case of greater nominal diameters of the rotary joint, long inner pipes or high speeds, it is recommended to separate the inner pipe in the area of the rotor connection as shown in the illustration.

B Operating Instructions for Rotary Joints Series DX/DXS

6. Mounting

Mounting with thread to rotor

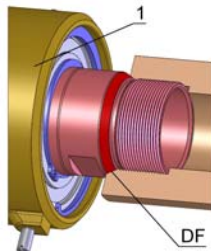

B-12

1. Clean the surfaces at the sealing cone [DF] and apply mounting paste.
2. Screw the rotary joint [1] into the roller.
3. If the rotor version is not a standard version, use a sealing ring or an O ring for sealing.

Mounting with K flange [2] and inner ring [3]

NOTE

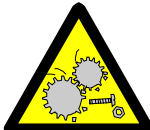

Mounting with K flange and screwed flange requires a minimum distance of [MA] ≥ 1 mm. Otherwise leakage may occur at the sealing element and the rotary joint, the inner pipe and the roller may be damaged:

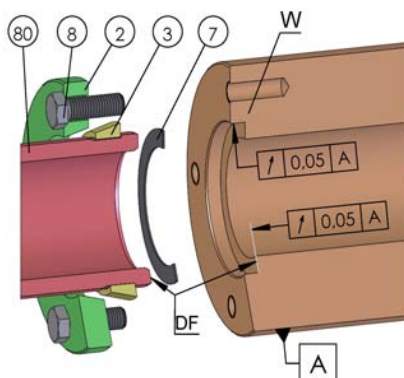

B-13

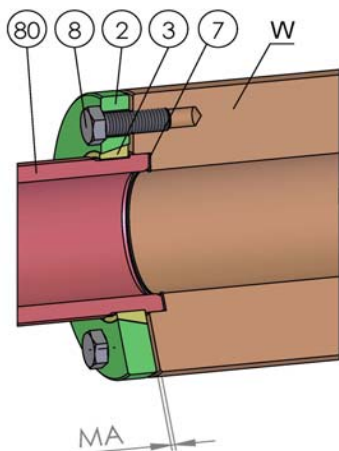

B-14

1. Clean sealing surfaces DF, apply mounting paste and place the sealing element [7] into roller [W].
2. The flat packing a standard sealing element can also be designed with a different element, e.g. O ring. Refer to the section "Specifications and Spare Parts" for additional information.
3. Mount K flange [2] with screws over rotor [80] and place inner ring [3] into rotor groove
4. Lift the rotary joint and insert it into the centering unit of the roller [W]. Versions with inner pipe: the inner pipe must be centered with reference to the rotary joint and the roller [W]. If you encounter resistance, check for correct position. Run-out and axial tension cause malfunctions of the rotary joint.
5. If you use a flat packing [7], the rotary joint must be aligned (refer to "Aligning the rotary joint in case of sealing with flat packing").
6. Assure the minimum distance [MA] - otherwise leakage will occur at the sealing element and the rotary joint and the inner pipe will be damaged:
 $MA \geq 1$ mm
7. Mount screws [8]. Maximum permissible tightening torque as per section "Specifications and Spare Parts".

B Operating Instructions for Rotary Joints Series DX/DXS

6. Mounting

Mounting with screwed flange [4]

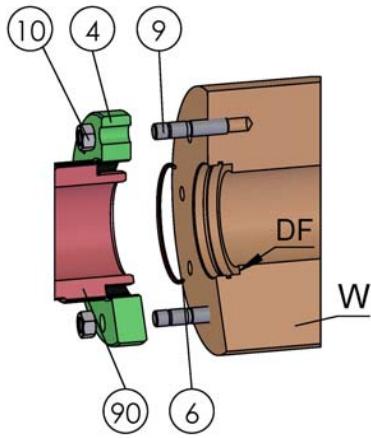

B-15

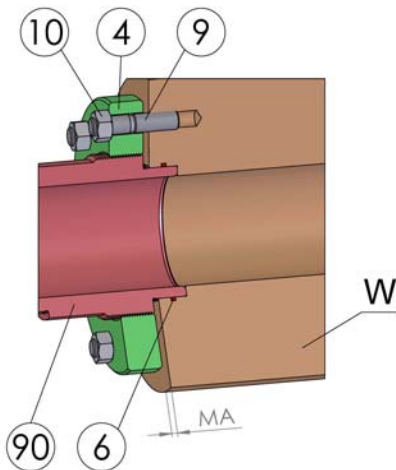

B-16

1. Clean sealing surfaces DF, apply mounting paste and place the sealing element [6] into roller [W].
2. The flat packing a standard sealing element can also be designed with a different element, e.g. O ring. Refer to the section "Specifications and Spare Parts" for additional information.
3. Screw flange [4] to rotor [90]. Make sure that dimension [MA] is obtained after mounting of rotor [90] to roller [W]. $MA \geq 1 \text{ mm}$. Otherwise leakage will occur at the sealing element and the rotary joint, the inner pipe or roller [W] will be damaged. Mount stud bolts [9].
4. Lift the rotary joint and insert it into the centering unit of the roller [W].
Versions with inner pipe: the inner pipe must be centered with reference to the rotary joint and the roller [W]. If you encounter resistance, check for correct position. Run-out and axial tension cause malfunctions of the rotary joint.
5. If you use a flat packing, the rotary joint must be aligned (refer to "Aligning the rotary joint in case of sealing with flat packing").
6. Assure the minimum distance [MA] - otherwise leakage will occur at the sealing element and the rotary joint and the inner pipe will be damaged: $MA \geq 1 \text{ mm}$
7. Mount nuts [10]. Maximum permissible tightening torque as per section "Specifications and Spare Parts".

B Operating Instructions for Rotary Joints Series DX/DXS

6. Mounting

Mounting with fixed flange (5)

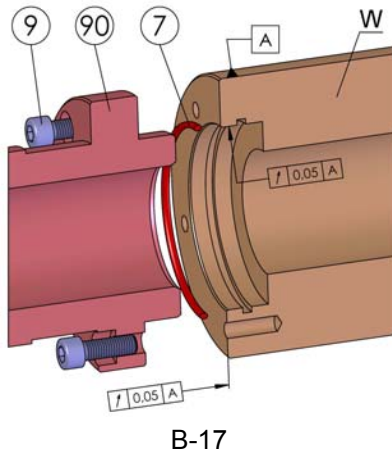

B-17

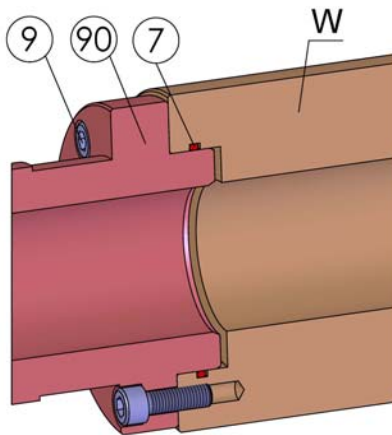

B-18

1. Mount the rotary joint to the roller [W].
2. Seal with flat packing [7].
3. Fasten the rotary joint with screws [9].
4. Clean sealing surfaces, apply mounting paste and place the sealing elements into roller [W].
5. Lift the rotary joint and insert it into the centering unit of the roller [W]. Versions with inner pipe: the inner pipe must be centered with reference to the rotary joint and the roller. If you encounter resistance, check for correct position. Run-out and axial tension cause malfunctions of the rotary joint.
6. Align the rotary joint (refer to section "Aligning the rotary joint in case of sealing with flat packing").
7. Assure the minimum distance [MA] - otherwise leakage will occur at the sealing element and the rotary joint and the inner pipe will be damaged:
 $MA \geq 1 \text{ mm}$
8. Mount screws [9]. Maximum permissible tightening torque as per section "Specifications and Spare Parts".

B Operating Instructions for Rotary Joints Series DX/DXS

6. Mounting

Aligning the rotary joint in case of sealing with flat packing

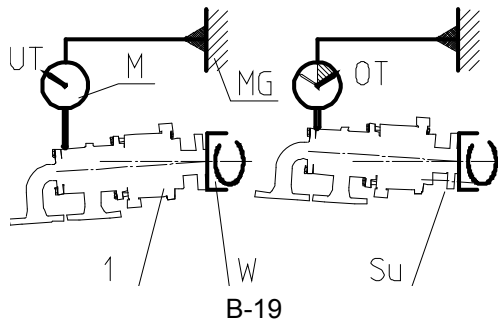

1. Place dial gauge [M] from the idle machine frame [MG] onto the rotary joint.
2. Rotate roller [W] until the dial gauge is at the bottom dead center [UT]. Mark the pointer position.
3. Rotate roller [W] until you reach the upper dead center [OT].
4. Tighten the bottom screws [Su] until the dial gauge is in the center position.
5. Repeat this alignment process until you reach the concentricity tolerance specified in the table below.
6. Tighten the screws with the permissible torque as per section "Specifications and Spare Parts"!

Permissible concentricity tolerance

DN	n (min ⁻¹ /rpm)		
	≤ 100	≤ 400	> 400
10 – 50	± 0.25 mm		
65 – 150		± 0.1 mm	

B Operating Instructions for Rotary Joints Series DX/DXS
6. Mounting

6.2 Connecting the rotary joint

⚠ WARNING



For safety reasons, always provide an anti-rotation system.

INFORMATION



Also refer to chapter 5. for important information on this section.

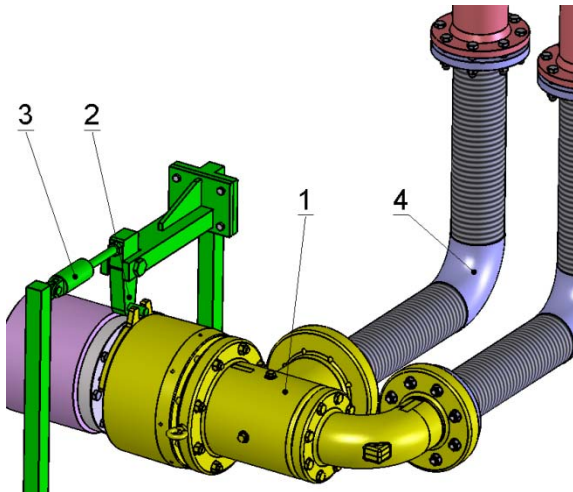

1. Mount anti-rotation device [2] of the rotary joint housing [1].
The information on the admissible mounting position of the rotary joint provided in the section "Specifications and Spare Parts" must be adhered to.
2. Mount torque monitoring system [3] or, as an alternative, a vibration pick-up to the anti-rotation device.
3. Connect the housing [4].
4. See the following sections for information on the correct design of the connection line.

General information on connection lines

The following sections show examples of the design of the flexible connection elements:

- ↔ permissible movement (go for)
- ↔ impermissible movement (avoid)

B Operating Instructions for Rotary Joints Series DX/DXS
6. Mounting



B-21

Do not compress or extend the lines.



B-22

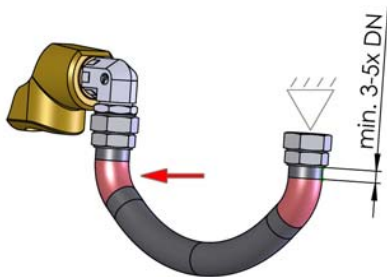

B-23

To increase the service life, add a length of 3-5x DN per connection to the length calculated on the basis of the permissible bending radius.



B-24

Avoid connection offset. Take length changes into account in the case of bending.

B Operating Instructions for Rotary Joints Series DX/DXS

6. Mounting

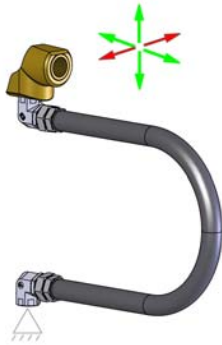

B-25

Take into account limited degrees of freedom and the minimum permissible bending radius.

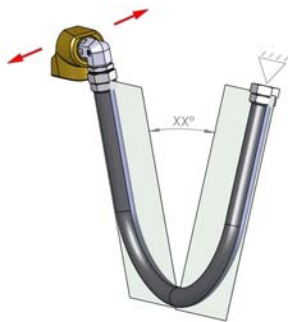

B-26



B-27

If possible, use fixed elbows, dual-line version, for bends.

All degrees of freedom are possible without tension if the length is sufficient.

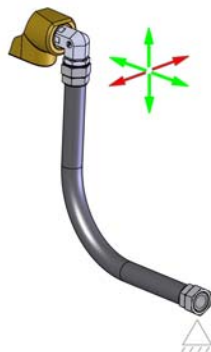

B-28



7. Operation

NOTE

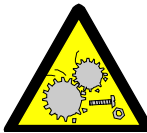

1. Dry-run causes damage to the rotary joint.
The rotary joint must not run dry.
Exception: test run for a maximum of 30 minutes and at very low speed.
2. Sudden temperature and pressure loads cause damage to the rotary joint.
Maximum temperature change during startup $\Delta T \leq 2 \text{ K/min}$.
3. Exceeding the permissible application data as per section "Specifications and Spare Parts" causes damage to the rotary joint. Avoid operating the unit under conditions involving several maximum values attained at the same time.

7.1 Commissioning

- During initial commissioning, minor amounts of drops of leaking fluid may occur during the breaking in period of the dynamic seal. The duration of the breaking in period depends on the speed and the pressure; usually, it is terminated after a few days.
- To avoid premature damage to seals in the rotary joint, it is recommended to check the installed filters for the fluid at more frequent intervals when a new system is commissioned for the first time. During this period, expect more pollution such as chips, rust or scales in the piping system. This is particularly true if the system has not been flushed prior to the initial startup.

7.2 During operation

Check the following:

- Centric arrangement of the rotor with reference to the roller driver
The radial deflection in the rear area of the housing must not exceed the values listed in the section "Permissible concentricity tolerance"
- Quality of the fluid in the system
Document the checked data. Refer to the section "Specifications and Spare Parts" for the required values.
- Visible leakage at the relief connection
The operating behavior of the rotating mechanical seal does not change suddenly. Slowly increasing leakage indicates seal failure. This way you can acquire values concerning the operating behavior of the rotary joint installed in the system.



7.3 Troubleshooting

Problem	Reason	Remedy
Leakage at the housing via the relief holes.	<ul style="list-style-type: none"> Rotating mechanical seal damaged or worn 	<ul style="list-style-type: none"> Install a new rotating mechanical seal Check the quality of the fluid and the status of the bearings
Noise and out-of-center run	<ul style="list-style-type: none"> Insufficient lubrication Bearing worn Bearing damage 	<ul style="list-style-type: none"> Repair; adhere to lubrication intervals! Replace rotary joint in case of damage
Friction torque exceeded	<ul style="list-style-type: none"> Bearing damage Seal damage Moving parts touch Permissible application data exceeded 	<ul style="list-style-type: none"> Inspection of the rotary joint or the system.
Leakage at sealing points	<ul style="list-style-type: none"> Flat packing or sealing element damaged Screw torque of connection insufficient 	<ul style="list-style-type: none"> Replace flat packing or sealing element during the next planned shutdown. In the case of considerable leakage, immediately shut down the rotary joint. Tighten the screws with the correct torque as per section "S Specifications and Spare parts". Do not overload screws as this will destroy them. Immediately replace overloaded screws!

8. Maintenance

INFORMATION



Maier offers on site service by our experts and training of your service staff.

- Observe the safety instructions in chapter 3.
- Maintenance may only be performed by authorized staff as per chapter 3.4.
- Work on the rotary joint may only be performed when the machine/system is at a standstill and after the rotary joint has cooled down.
- Always wear safety glasses when performing work on the rotary joint to protect against escaping fluid.
- Use only genuine spare parts.
- If you have removed protective equipment, refit such equipment after having finished your work and verify proper operation of such equipment.
- All screws must be tightened with the specified tightening torque (refer to section "Specifications and Spare Parts").

8.1 Maintenance plan

Interval	Activity	Explanation
Refer to section "Specifications and Spare Parts"	<ul style="list-style-type: none">• Relubricate the rolling bearings if a lubricating nipple is installed	Refer to the section "Specifications and Spare Parts" for the lubricant quantity
Every 12 months	<ul style="list-style-type: none">• Check bearings• Check seals	Repair can be performed by Maier customer service.

8.2 Repair

8.2.1 Tools

- Suitable lifting gear must be used to mount the rotary joint to the roller.
- A torque wrench must be used for tightening screws with a specified tightening torque.



B Operating Instructions for Rotary Joints Series DX/DXS

8. Maintenance

8.2.2 Repair work

8.2.2.1 Dismounting the rotary joint from the roller

Prerequisites:

- Unpressurize the rotary joint.
- Drain the fluid contained in the roller.
- Remove the protective hood and the torque supports.

Procedure: **WARNING**

Risk of injury caused by escaping fluid under pressure.
Make sure that shut-off fittings cannot be opened inadvertently or intentionally during repair work.

INFORMATION

Refer to the operating instructions for the complete system for any further information on properly performing the preparation work.

1. Dismount the housing connections.
2. Secure the rotary joint with a belt (nominal diameter 32 - 80) or via the eye bolt (nominal diameter 100 and greater) and a crane.
3. Loosen the connection between rotor and roller.
 - In the case of thread at rotor by unscrewing with wrench at wrench surfaces.
 - In the case of flange connection at rotor by removing the screws at the flange. Slowly pull the rotary joint out of the flange. If the rotary joint cannot be pulled out easily, loosen it from the centering unit by slightly moving it up and down with the crane.

B Operating Instructions for Rotary Joints Series DX/DXS

8. Maintenance

8.2.2.2 Dismounting the rotary joint

Prerequisite

- The rotary joint must have been dismantled from the roller.

INFORMATION



The design of the rotary joints is shown in the section "Specifications and Spare Parts".

Rotary joint with one-piece housing

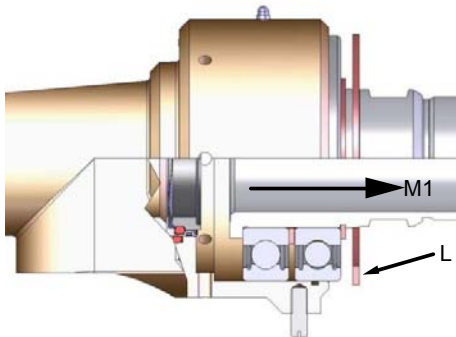

B-29

1. Remove circlip [L] in the housing of the rotary joint.
2. Remove the rotor [M1] with the bearing from the housing.

Rotary joint with housing consisting of several pieces

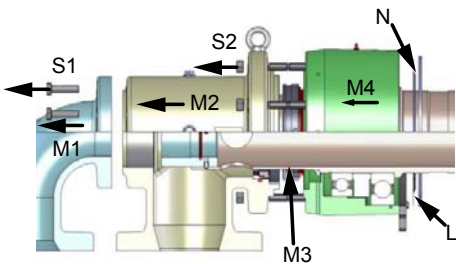

B-30

1. Remove the screw connections [S1 + S2].
2. Remove the housing parts [M1 + M2].
3. Dismount the counter ring [M3] from the rotor.
4. Remove the circlip [L] and the Nilos ring [N] from the bearing housing.
5. Dismount the bearing housing [M4].
6. Dismount all parts, in particular the installed seals and bearings.

Dismounting the rotating mechanical seal

INFORMATION



The rotating mechanical seal of rotary joints with nominal diameters 10 – 80 can be removed with an extractor (A) without damage.
Refer to the section "Specifications and Spare Parts" for the ordering numbers of the extractors.

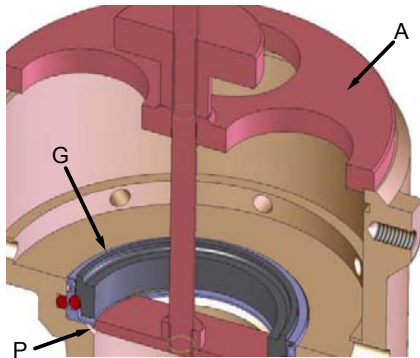

B-31

1. Pull off the rotating mechanical seal [G] at position [P].

8.2.2.3 Evaluating the individual parts

Prerequisite

- The rotary joint must have been dismantled.

INFORMATION



The wearing parts V listed in the spare parts list in the section "Specifications and Spare Parts" must be replaced.
The spare parts E listed must be evaluated before they are re-used.
If you re-use them, you must thoroughly clean them with a solvent that does not leave residue (such as propyl alcohol and cellulose cloth).

Evaluating the roller bearings

- Quantity and condition of the existing lubricant:
If the lubricant no longer has its normal consistency, this indicates unfavorable operating conditions. It is recommended to always renew the lubricant.
- Color and surface quality of the outer ring and the inner ring as well as the rolling element:
If the surfaces are discolored or if there are grooves, the bearing is worn and must be replaced.
- Checking the smoothness:
If the bearing does not run smoothly or if the axial bearing backlash is too high, the bearing is worn and must be replaced.

B Operating Instructions for Rotary Joints Series DX/DXS

8. Maintenance

Evaluating the sealing surfaces

- The rotating mechanical seal must be replaced! The wearing height at the carbon sealing ring should be at least 2 mm. Axial movements of the spring-loaded carbon sealing ring must be possible.
- Pay particular attention to the quality of the sealing surfaces. When new, the sealing surfaces are lapped. Before re-using the sealing parts, you must lap them again!

8.2.2.4 Mounting the rotary joint

NOTE

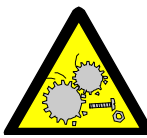

Never lubricate or grease the sealing surfaces of the rotating mechanical seal!

Apply a very thin layer of a suitable lubricant to the Eastover sealing rings (O rings) and shaft sealing rings. They must never come into contact with mineral oil-based lubricants (seal failure a result of expansion or decomposition! Use "Parker Super-O-Lube" as a mounting aid.

Never apply excessive force during mounting!

Prerequisite

- Only use new spare parts and wearing parts.

Mounting

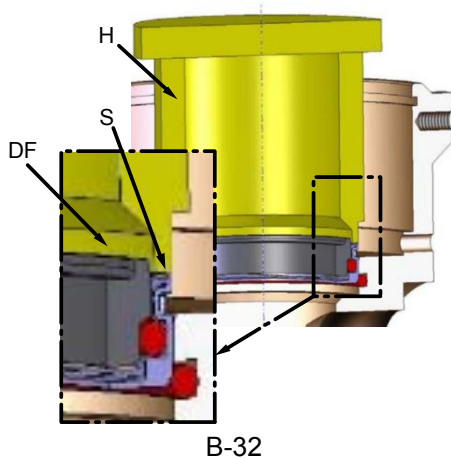

1. The spare parts are mounted in the same way as they are dismantled, but in reverse order.
2. Special note on mounting the rotating mechanical seal:
Never press on the sealing surface [DF] of the carbon ring for mounting. It is recommended to use a mounting bushing [H] to insert the rotating mechanical seal at the housing shoulder [S] of the rotating mechanical seal.
3. Prior to the next mounting steps, clean the sealing surfaces [DF] at the inserted rotating mechanical seal and at the rotor / counter ring with a solvent that does not leave residue. Do not grease or oil the sealing surfaces.
4. Refer to the section "Specifications and Spare Parts" for the recommended lubricant and volume for initial greasing of the roller bearings.



S Specifications and spare parts

Contents

1. Application data	2
2. Tightening torques in Nm for fastening screws.....	2
3. Initial lubrication and relubrication	3
4. Extracting tools	3
5. Limit values for the friction torque at the rotary joint	4
6. Fluids specifications	5
7. Outline drawings.....	6
7.1 DX1 + DXS 1, passage of one fluid in one direction, DN 10-80.....	6
7.2 DX2 + DXS 2, passage of one fluid in two directions with stationary inner pipe, DN 10-80	7
7.3 DXR2 + DXSR 2, passage of one fluid in two directions with rotating inner pipe DN 15-80.....	8
7.4 DSB2, passage of one fluid in two directions with rotating inner pipe, DN 50-80	9
7.5 DXS 1, passage of one fluid in one direction, DN 100-150.....	10
7.6 DXS 2, passage of one fluid in two directions with stationary inner pipe, DN 100-150	11
7.7 DXSB 2, passage of one fluid in two directions, rotating inner pipe, DN 100-150.....	12
8. Spare parts.....	13
8.1 DX1 + DXS1, DX2 + DXS2, DXR2 + DXSR2, DN 10 – 80	13
8.2 DXSB2, DN 50 – 80	14
8.3 DXS 1, DN 100 – 150	15
8.4 DXSB 2, DN 100 – 150	15
8.5 DXSB 2, DN 100 – 150	16



S Specifications and Spare Parts Series DX / DXS

1. Application data

1. Application data

	DX	DXS	DXS	DXS	DXS-200
Version	1, 2, R2	1, 2	R2	B2	1, 2, B2
Nominal diameter DN [mm]	10...80	10...80	10...80	50...80	100...150
Fluid	Water as per fluids specification				
Mounting position	Any; however, the position of the relief connection at the housing must allow for safe draining of leaking fluid				
Temperature max. °C	-10...80	-10...150	-10...150	-10...150	-10...150
Pressure PN, min...max. bar	-0.2...8	-0.2...8	-0.2...8	-0.2...8	-0.2...8
Test pressure during standstill max. bar	11.5	11.5	11.5	11.5	11.5
Speed max. min ⁻¹	<u>50000</u> DN	<u>55000</u> DN	<u>50000</u> DN	<u>55000</u> DN	DN100:300 DN125:300 DN150:100

2. Tightening torques in Nm for fastening screws

Property class 5.6 at screw temperature						
Size	20°C	100°C	150°C	200°C	250°C	300°C
M6	4.0	3.6	3.4	3.1	2.9	2.7
M8	10.0	9.0	8.5	7.9	7.3	6.6
M10	18	16	15	14	13	12
M12	37	33	31	29	26	24
M16	90	81	76	71	65	60
M20	175	158	148	138	127	116
Property class 8.8 at screw temperature						
Size	20°C	100°C	150°C	200°C	250°C	300°C
M6	10.0	9.3	8.9	8.4	8.0	7.5
M8	24.0	22.3	21.3	20.3	19.1	18.0
M10	48	45	43	41	38	36
M12	82	76	73	69	65	62
M16	206	192	183	174	164	155
M20	400	372	355	338	319	300

S Specifications and Spare Parts Series DX / DXS

3. Initial lubrication and relubrication

3. Initial lubrication and relubrication

Lubricants	The rotary joints are factory-lubricated with PETAMO GY 193 by Klüber Lubrication KG. (Phone: +49-(0)89-7876-271 www.klueber.com) Relubrication at nipple – used grease escapes via the bearing housing. Attention: Warranty is forfeited when using greases not approved by us.														
Volume at ...	DN	mm	10	15	20	25	32	40	50	65	80	100	125	150	
Initial lubrication (Q_E)	Bearing 1	cm ³	1,5	3	5	6	12	15	28	45	100	120	210	300	
	Bearing 2	cm ³	1,5	3	5	6	12	15	28	45	100	60	105	150	
Relubrication (Q_N)	Rotary joint	Strokes	2	4	5	6	8	10	15	20	40	50	70	100	
	<p>1 Grease volume as recommended value for one bearing (spaces filled to 50%)</p> <p>2 Strokes of a grease gun as per DIN 1283 with 1.2 cm³ per stroke and rotary joint</p> <p>The relubrication intervals are recommended values. Reduce the intervals to one half in the case of exceptional operating or environmental conditions (such as high pressures or loads, heavy machine vibrations or polluted bearing grease). Experiences of the owner/operator can be considered in optimizing the lubrication intervals.</p>														
Temperature	up to 80 °C			80 °C to 120 °C			120 °C to 140 °C			140 °C to 150 °C					
Intervals	Factory lifetime lubrication			Every 6 months			Every 12 weeks			Every 2 weeks					

4. Extracting tools

DX / DXS	Product no.
10	1190325
15	1190326
20	1190327
25	1190328
32	1190329
40	1190330
50	1190331
65	1190332
80	1190333

S Specifications and Spare Parts Series DX / DXS

5. Limit values for the friction torque at the rotary joint

5. Limit values for the friction torque at the rotary joint

Maier series DX / DXS rotary joints are equipped with contacting seals and rolling bearings. The table below lists the friction torque depending on the nominal width DN generated during rotation at maximum operating pressure and speed of rotation to allow for torque monitoring recommended for safety reasons.

The following applies to the individual columns:

Column Normal:	The friction torque to be expected during normal operation.
Column Warning:	If these values are exceeded, the rotary joint and the installation should be checked within the next 3 days.
Column Stop:	If these values are exceeded, stop the rotary joint immediately for safety reasons; check and repair it, if necessary!

Friction torque for Maier rotary joints series DX / DXS at maximum pressure PN (Observe the information provided below)

DN	Normal in Nm	WARNING in Nm	STOP in Nm
10 - 25	3	6	9
32 - 40	7	14	21
50	11	22	33
65	15	30	45
80	20	40	60
100	32	64	96
125	50	100	150
150	80	160	240

Further torques may be generated during operation of the rotary joint in addition to the friction torques listed. These additional torques may be caused by tilting as a result of horizontal housing connection pieces, shut-off valves mounted directly to the housing connection piece or by righting forces generated by the metal hoses for the supply of the fluid. If the roller with the connected rotary joint is to move during running, the hoses may also cause additional loads as a result of righting forces of the hoses.

All these additional loads which cause an additional torque must be considered in defining the switching point for the pre-alarm and the main alarm.



6. Fluids specifications

Series DX / DXS rotary joints may be used for water having the quality described below. Other fluids including additives for the water (e.g. anticorrosion or antifreeze agents) must be checked for compatibility with the materials used in the manufacturer's plant.

General

The quality of the water used plays a decisive role in the service life and reliability of a Maier rotary joint. It is strongly recommended to observe the specifications listed below. Insufficient water quality will result in heavy wear of the seal and premature failure of the rotary joint.

Section 1

Water with temperatures from 10°C to 70°C

- Raw water: drinking water quality
- General: clear, no sediments
- Filtration: particle size 20 µm, max. 50µm
- Water hardness: < 3.2 mmol/l
- Low salt concentration according to VdTÜV- Guideline TCh 1466 "Guideline for Circulation Water in Hot Water and Warm Water Heating Systems" ("Richtlinie für das Kreislaufwasser in Heißwasser – und Warmwasserheizungsanlagen), sheet 1.
- If required, add a suitable antifreeze agent and a silicate-free anticorrosion agent (ensure compatibility with the materials used in the unit, check back with manufacturer, if necessary).

Section 2

Water with a temperature of > 70°C

- Raw water: drinking water quality
- General: clear, no sediments
- Filtration: particle size 20 µm, max. 50µm
- Water hardness: < 3.2 mmol/l
- Low salt concentration according to VdTÜV- Guideline TCh 1466 "Guideline for Circulation Water in Hot Water and Warm Water Heating Systems" ("Richtlinie für das Kreislaufwasser in Heißwasser – und Warmwasserheizungsanlagen), sheet 1.
- If required, add a suitable antifreeze agent and a silicate-free anticorrosion agent (ensure compatibility with the materials used in the unit, check back with manufacturer, if necessary).

S Specifications and Spare Parts Series DX / DXS

7. Outline drawings

7. Outline drawings

7.1 DX1 + DXS 1, passage of one fluid in one direction, DN 10-80

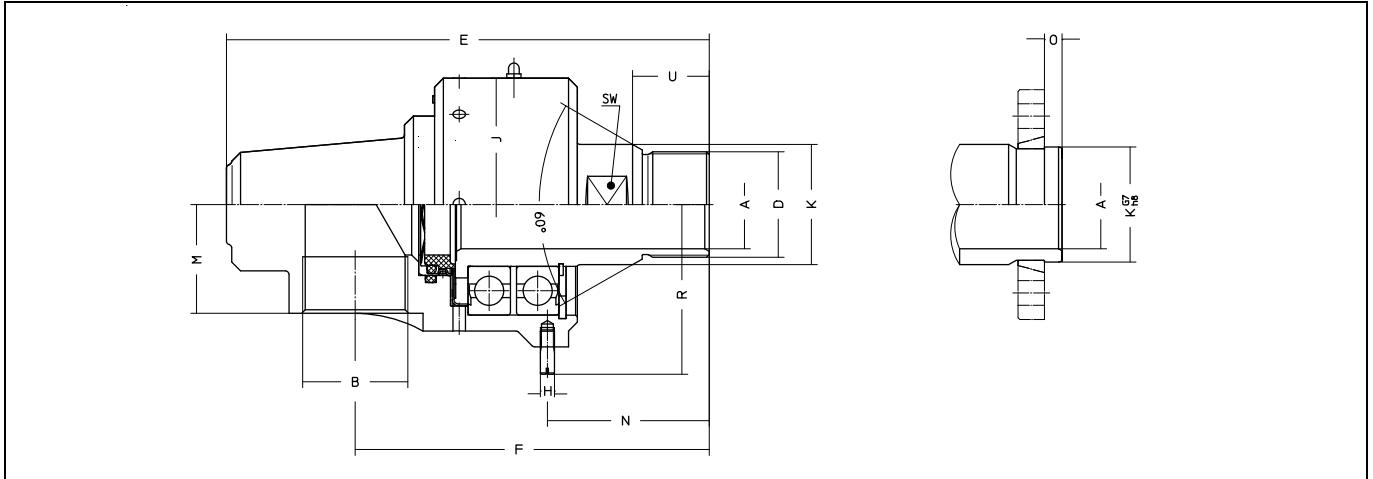

DNmm	10	15	20	25	32	40	50	65	80
Type	DX 110 R	DX 115 R	DX 120 R	DX 125 R	DX 132 R	DX 140 R	DX 150 R	DX 165 R	DX 180 R
Ordering no.	1106000	1106050	1106100	1106150	1106200	1106250	1106300	1106350	1106400
Type	DX 110 L	DX 115 L	DX 120 L	DX 125 L	DX 132 L	DX 140 L	DX 150 L	DX 165 L	DX 180 L
Ordering no.	1106001	1106051	1106101	1106151	1106201	1106251	1106301	1106351	1106401
Type	DX 110 K	DX 115 K	DX 120 K	DX 125 K	DX 132 K	DX 140 K	DX 150 K	DX 165 K	DX 180 K
Ordering no.	1106002	1106052	1106102	1106152	1106202	1106252	1106302	1106352	1106402
Type	DXS 110 R	DXS 115 R	DXS 120 R	DXS 125 R	DXS 132 R	DXS 140 R	DXS 150 R	DXS 165 R	DXS 180 R
Ordering no.	1105000	1105075	1105150	1105225	1105300	1105375	1105450	1105525	1105600
Type	DXS 110 L	DXS 115 L	DXS 120 L	DXS 125 L	DXS 132 L	DXS 140 R	DXS 150 L	DXS 165 L	DXS 180 L
Ordering no.	1105001	1105076	1105151	1105226	1105301	1105376	1105451	1105526	1105601
Type	DXS 110 K	DXS 115 K	DXS 120 K	DXS 125 K	DXS 132 K	DXS 140 K	DXS 150 K	DXS 165 K	DXS 180 K
Ordering no.	1105002	1105077	1105152	1105227	1106302	1105377	1105452	1105527	1105602

ØA	10	13	20	25	32	38	50	66	80
B	G $\frac{3}{8}$	G $\frac{1}{2}$	G $\frac{3}{4}$	G1	G1 $\frac{1}{4}$	G1 $\frac{1}{2}$	G2	G2 $\frac{1}{2}$	G3
D	G $\frac{3}{8}$ A	G $\frac{1}{2}$ A	G $\frac{3}{4}$ A	G1A	G1 $\frac{1}{4}$ A	G1 $\frac{1}{2}$ A	G2A	G2 $\frac{1}{2}$ A	G3 $\frac{1}{2}$ A
E	119	139	151	168	208	227	274	313	378
F	94	110	118	129	156	167	201	225	278
ØH	5	5	5	6	6	8	8	10	10
ØJ	54	65	75	85	105	115	143	170	222
ØK	20	25	30	35	48	52	68	84	108
ØKG7/h8	18	24	30	35	45	50	65	85	105
M	24	29	33	37	45	49	61	70	96
N	42	48	50	59	68	75	92	100	125
O	6	6	8	8	8	10	10	10	12
R	43	48	53	63	73	83	97	114	140
U	19	23	23	28	33	36	43	48	54
SW	17	22	27	30	41	46	60	75	95
Weight (kg)	0.9	1.5	2	2.6	4.9	6.4	11	17.8	35.5

72

DX2 + DXS 2, passage of one fluid in two directions with stationary inner pipe, DN 10-80

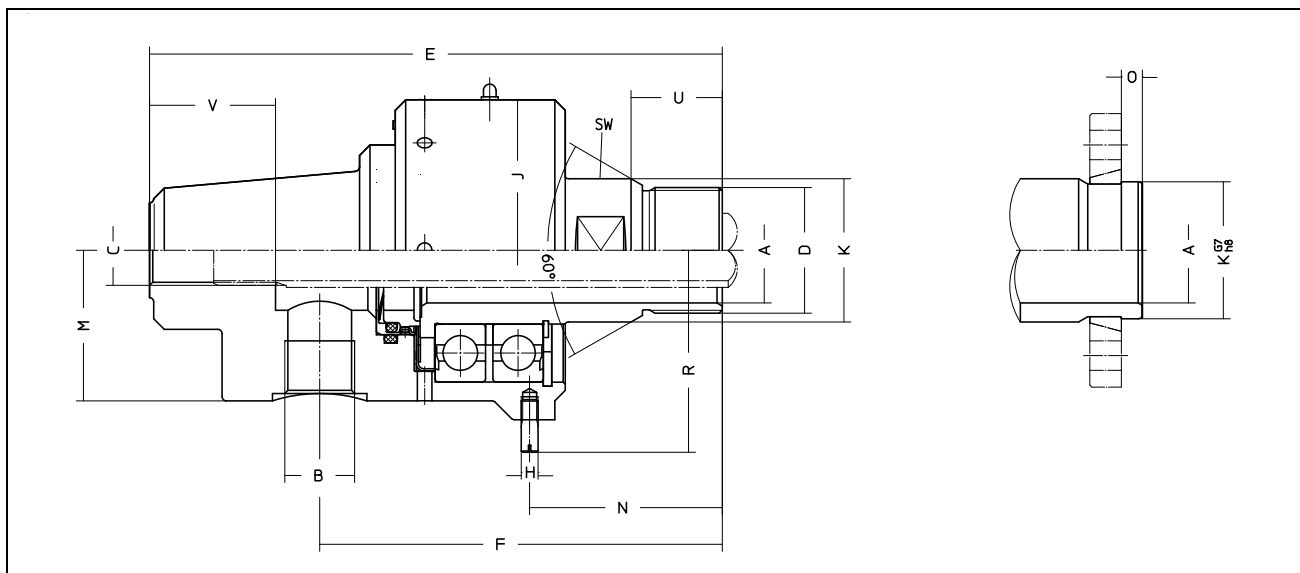

DNmm	10	15	20	25	32	40	50	65	80
Type	DX210R	DX215R	DX220R	DX225R	DX232R	DX240R	DX250R	DX265R	DX280R
Ordering no.	1106003	1106053	1106103	1106153	1106203	1106253	1106300	1106353	1106403
Type	DX210L	DX215L	DX220L	DX225L	DX232L	DX240L	DX250L	DX265L	DX280L
Ordering no.	1106004	1106054	1106104	1106154	1106204	1106254	1106304	1106354	1106404
Type	DX210K	DX215K	DX220K	DX225K	DX232K	DX240K	DX250K	DX265K	DX280K
Ordering no.	1106005	1106055	1106105	1106155	1106205	1106255	1106305	1106355	1106405
Type	DXS210R	DXS215R	DXS220R	DXS225R	DXS232R	DXS240R	DXS250R	DXS265R	DXS280R
Ordering no.	1105004	1105079	1105154	1105229	1105304	1105379	1105454	1105559	1105604
Type	DXS210L	DXS215L	DXS220L	DXS225L	DXS232L	DXS240R	DXS250L	DXS265L	DXS280L
Ordering no.	1105005	1105080	1105155	1105230	1105305	1105380	1105455	1105530	1105605
Type	DXS210K	DXS215K	DXS220K	DXS225K	DXS232K	DXS240K	DXS250K	DXS265K	DXS280K
Ordering no.	1105006	1105081	1105156	1105231	1106306	1105381	1105456	1105531	1105606

ØA	10	13	20	25	32	38	50	66	80
B	G ¹ / ₈	G ¹ / ₈	G ¹ / ₄	G ³ / ₈	G ¹ / ₂	G ³ / ₄	G1	G ¹ / ₂	G2
C	G ¹ / ₈ M8x0,5	G ¹ / ₈	G ¹ / ₄	G ³ / ₈	G ¹ / ₂	G ³ / ₄	G1	G ¹ / ₂	G2
D	G ³ / ₈ A	G ¹ / ₂ A	G ³ / ₄ A	G1A	G ¹ / ₄ A	G ¹ / ₂ A	G2A	G ² / ₂ A	G ³ / ₂ A
E	118	138	150	167	207	226	273	312	377
F	92	106	114	124	149	162	192	512	268
ØH	5	5	5	6	6	8	8	10	10
ØJ	54	65	75	85	105	115	143	170	222
ØK	20	25	30	35	48	52	68	84	108
ØKG7/h8	18	24	30	35	45	50	65	85	105
M	26	31	36	40	50	54	68	80	105
N	42	48	50	59	68	75	92	100	125
O	6	6	8	8	8	10	10	10	12
R	43	48	53	63	73	83	97	114	140
U	19	23	23	28	33	36	43	48	54
V	20	25	30	35	45	50	60	70	80
SW	17	22	27	30	41	46	60	75	95
Weight									
kg	0.8	1.4	1.9	2.5	4.8	6.2	10.8	17.5	35

S Specifications and Spare Parts Series DX / DXS

7. Outline drawings

7.3 DXR2 + DXSR 2, passage of one fluid in two directions with rotating inner pipe DN 15-80

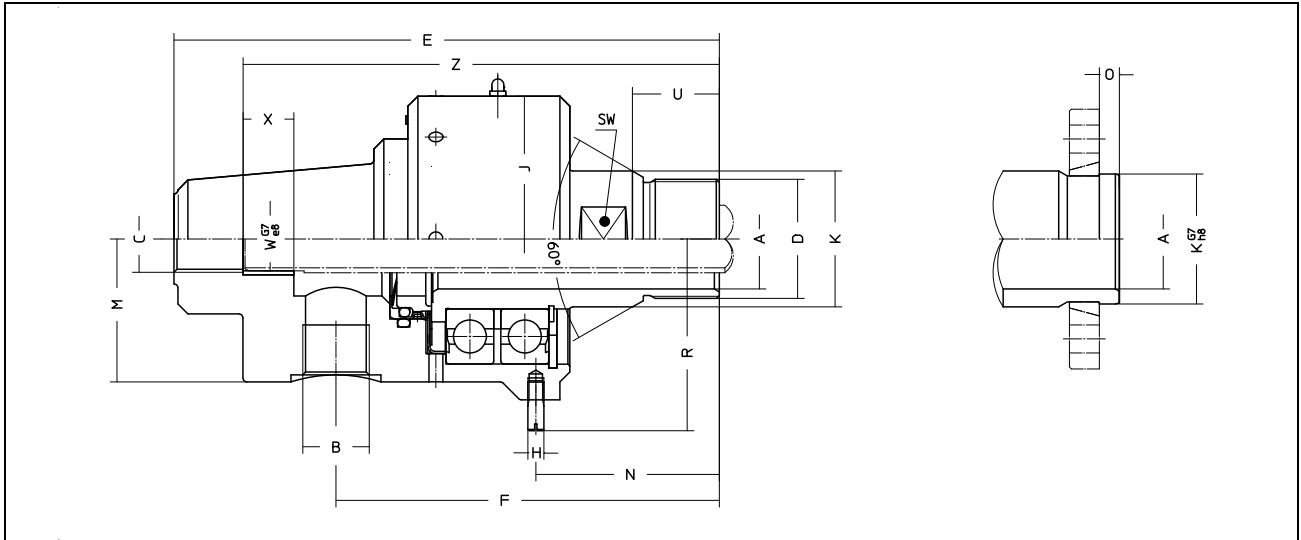

DN mm	15	20	25	32	40	50	65	80
Type	DXR 215 R	DXR 220 R	DXR 225 R	DXR 232 R	DXR 240 R	DXR 250 R	DXR 265 R	DXR 280 R
Ordering no.	1106056	1106106	1106156	1106206	1106256	1106306	1106356	1106406
Type	DXR 215 L	DXR 220 L	DXR 225 L	DXR 232 L	DXR 240 L	DXR 250 L	DXR 265 L	DXR 280 L
Ordering no.	1106057	1106107	1106157	1106207	1106257	1106307	1106357	1106407
Type	DXR 215 K	DXR 220 K	DXR 225 K	DXR 232 K	DXR 240 K	DXR 250 K	DXR 265 K	DXR 280 K
Ordering no.	1106058	1106108	1106158	1106208	1106258	1106308	1106358	1106408
Type	DXSR 215 R	DXSR 220 R	DXSR 225 R	DXSR 232 R	DXSR 240 R	DXSR 250 R	DXSR 265 R	DXSR 280 R
Ordering no.	1105083	1105158	1105233	1105308	1105375	1105483	1105533	1105608
Type	DXSR 215 L	DXSR 220 L	DXSR 225 L	DXSR 232 L	DXSR 240 L	DXSR 250 L	DXSR 265 L	DXSR 280 L
Ordering no.	1105084	1105159	1105234	1105309	1105384	1105459	1105534	1105609
Type	DXSR 215 K	DXSR 220 K	DXSR 225 K	DXSR 232 K	DXSR 240 K	DXSR 250 K	DXSR 265 K	DXSR 280 K
Ordering no.	1105085	1105160	1105235	1106310	1105385	1105460	1105535	1105610

Ø A	13	20	25	32	38	50	66	80
B	G $\frac{1}{8}$	G $\frac{1}{4}$	G $\frac{3}{8}$	G $\frac{1}{2}$	G $\frac{3}{4}$	G1	G $1\frac{1}{2}$	G2
C	G $\frac{1}{8}$	G $\frac{1}{4}$	G $\frac{3}{8}$	G $\frac{1}{2}$	G $\frac{3}{4}$	G1	G $1\frac{1}{2}$	G2
D	G $1\frac{1}{2}$ A	G $3\frac{1}{4}$ A	G1A	G $1\frac{1}{4}$ A	G $1\frac{1}{2}$ A	G2A	G $2\frac{1}{2}$ A	G $3\frac{1}{2}$ A
E	138	150	167	207	226	273	312	377
F	106	114	124	149	162	192	215	268
Ø H	5	5	6	6	8	8	10	10
Ø J	65	75	85	105	115	143	170	222
Ø K	25	30	35	48	52	68	84	108
Ø KG7/h8	24	30	35	45	50	65	85	105
M	31	36	40	50	54	68	80	105
N	48	50	59	68	75	92	100	125
O	6	8	8	8	10	10	10	12
R	48	53	63	73	83	97	114	140
U	23	23	28	33	36	43	48	54
Ø WG7/e8	10	12	16	20	25	31,8	45	60
X	15	15	15	15	25	25	30	40
Z	128	135	147	177	201	238	373	337
SW	22	27	30	41	46	60	75	95
Weight (kg)	1.5	2.1	2.8	5.1	6.5	11.5	18.2	36.5

S Specifications and Spare Parts Series DX / DXS
7. Outline drawings

7.4 **DSB2, passage of one fluid in two directions with rotating inner pipe, DN 50-80**

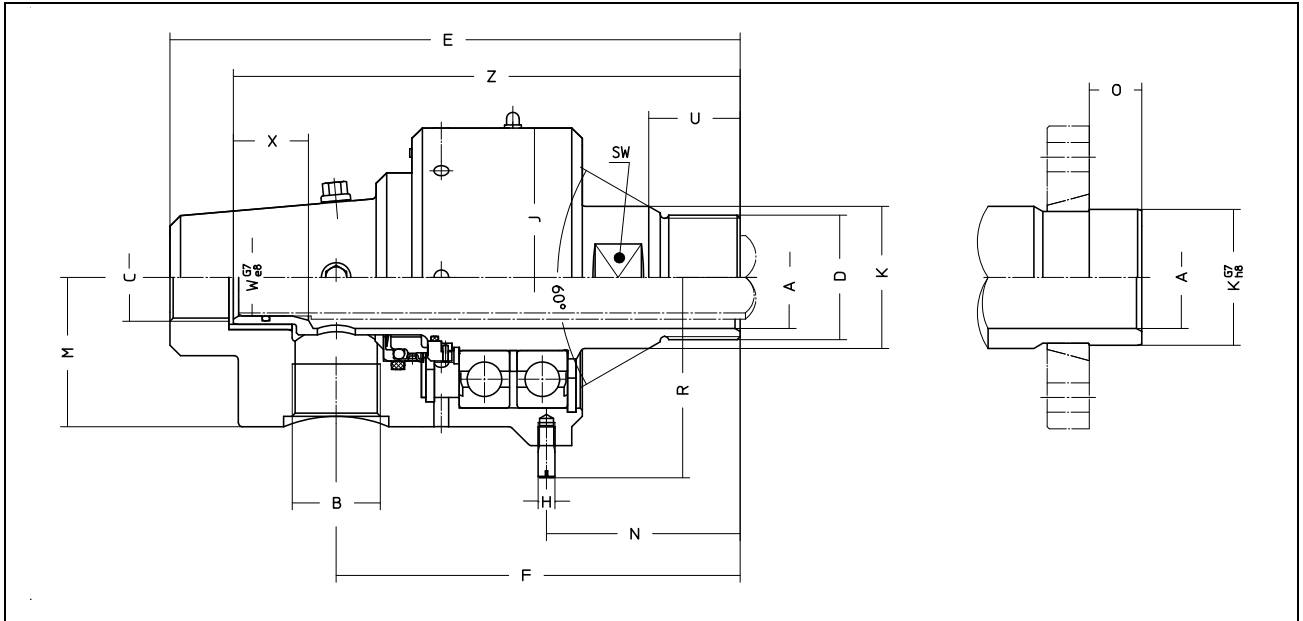

DNmm	50	65	80
Type	DXSB 250 R	DXSB 265 R	DXSB 280 R
Ordering no.	1105466	1105541	1105616
Type	DXSB 250 L	DXSB 265 L	DXSB 280 L
Ordering no.	1105467	1105542	1105617
Type	DXSB 250 K	DXSB 265 K	DXSB 280 K
Ordering no.	1105468	1105543	1105618

ØA	49	63	78
B	G 1¼	G 1½	G 2
C	G 1¼	G 1½A	G 2
D	G 2A	G 2½A	G 3½A
E	271	312	377
F	192	215	268
ØH	8	10	10
ØJ	143	170	222
ØK	68	84	108
ØKG7/h8	65	85	105
M	65	80	105
N	92	100	125
O	25	25	30
R	97	114	140
U	43	48	54
ØWG7/e8	37	45	60
X	35	47	40
Z	241	274	334
SW	60	75	95
Weight (kg)	12	19	40

S Specifications and Spare Parts Series DX / DXS
7. Outline drawings

7.5 **DXS 1, passage of one fluid in one direction, DN 100-150**

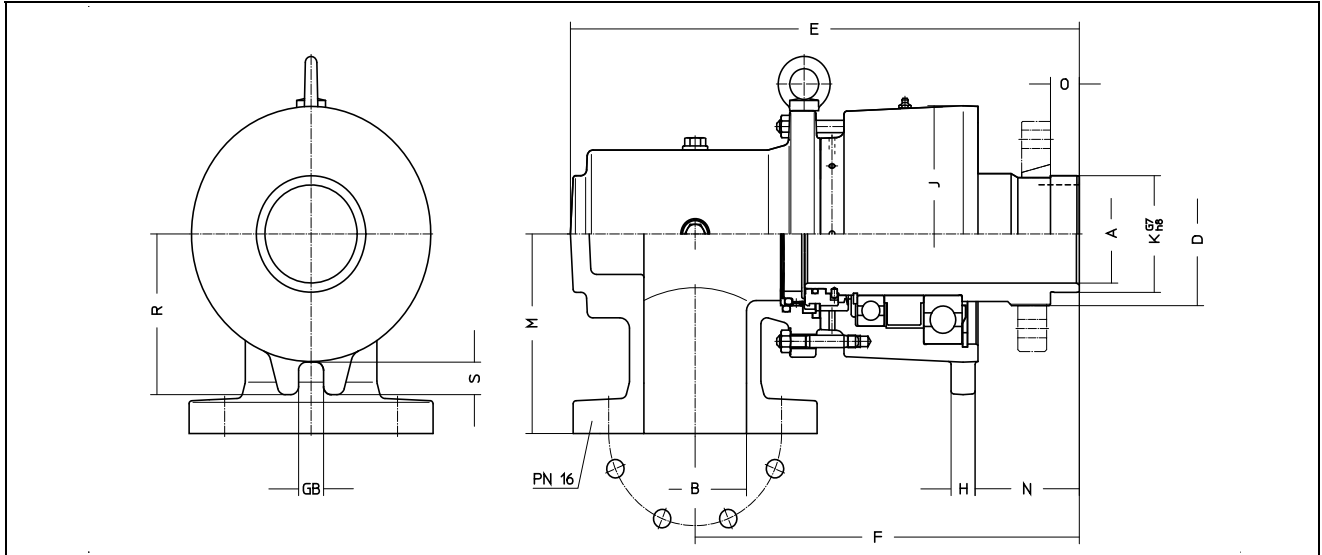

DN mm	100	125	150
Type	DXS 1100 K-200	DXS 1125 K-200	DXS 180 K-200
Ordering no.	1105677-200	1105752-200	1105827-600
Type	DXS 150 F-200	DXS 165 F-200	DXS 180 F-200
Ordering no.	1105678-200	1105753-200	1105828-200

Ø A	96	118	150
B (DIN 2633)	100	125	150
Ø D	M 140x2	M 168x3	M 205x3
E	530	603,5	694
F	400	460	530
H	25	30	15
Ø J	251	302,5	364
Ø KG7/h8	114	150	180
M	195	230	260
N	108,5	129	121,5
O	30	35	40
R	157	187	216,2
S	31,5	35,5	35
GB	26	30	30
Weight (kg)	70	124	198

76

DXS 2, passage of one fluid in two directions with stationary inner pipe, DN 100-150

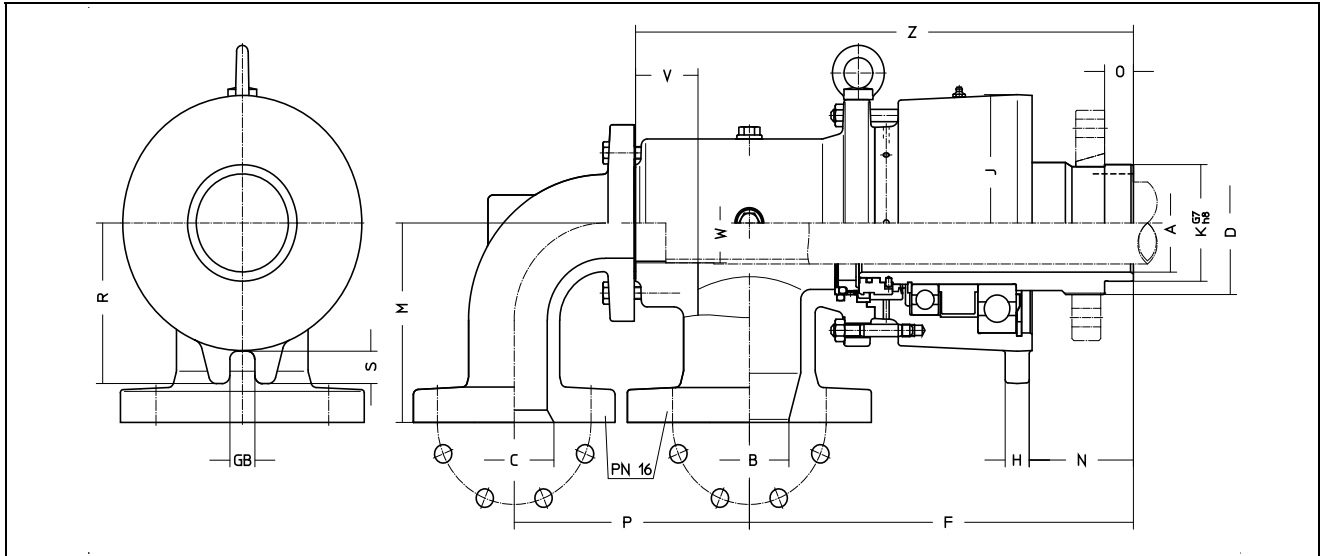

DNmm	100	125	150
Type	DXS 2100 K-200	DXS 2125 K-200	DXS 280 K-200
Ordering no.	1105681-200	1105756-200	1105831-600
Type	DXS 250 F-200	DXS 265 F-200	DXS 280 F-200
Ordering no.	1105682-200	1105757-200	1105832-200

Ø A	96	118	150
B (DIN 2633)	80	100	125
C (DIN 2633)	80	100	125
Ø D	M 140x2	M 168x3	M 205x3
F	400	460	530
H	25	30	15
Ø J	251	302,5	364
Ø K G7/h8	114	150	180
M	195	230	260
N	108,5	129	121,5
O	30	35	40
P	245	285	325
R	157	187	216,2
S	31,5	35,5	35
V	65	70	68
Ø W	G 2½	G 3	G 4
Z	518	595	676
GB	26	30	30
Weight (kg)	85	135	230

S Specifications and Spare Parts Series DX / DXS
7. Outline drawings

7.7 DXSB 2, passage of one fluid in two directions, rotating inner pipe, DN 100-150

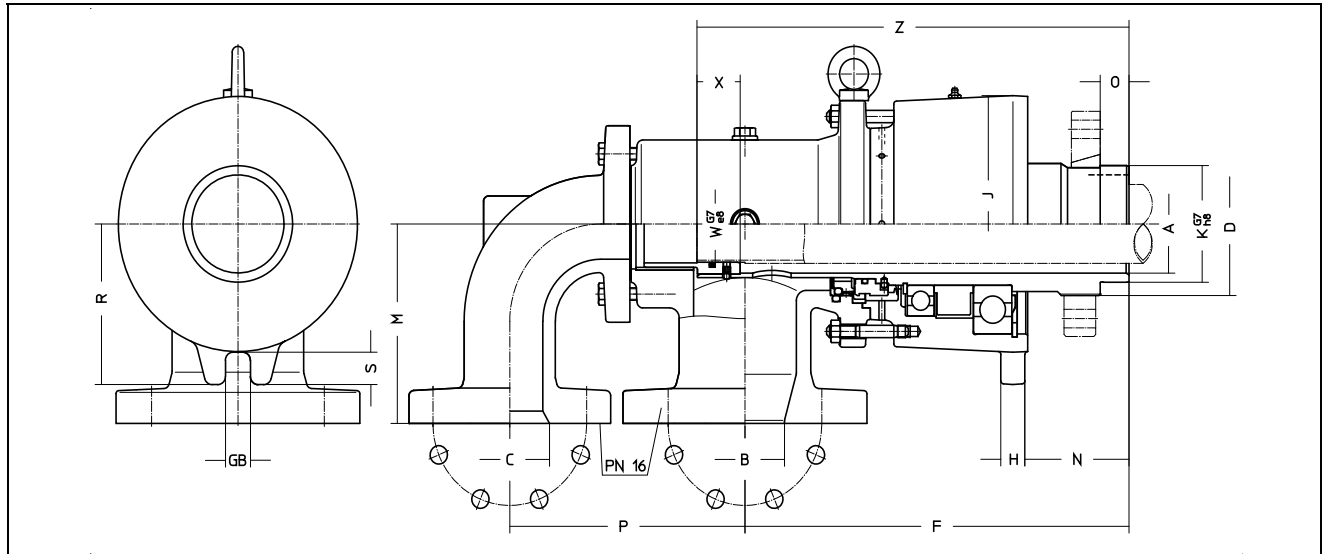

DN mm	100	125	150
Type	DXSB 2100 K-200	DXSB 2125 K-200	DXSB 280 K-200
Ordering no.	1105693-200	1105766-200	1105841-600
Type	DXSB 250 F-200	DXSB 265 F-200	DXSB 280 F-200
Ordering no.	1105694-200	1105767-200	1105842-200

Ø A	96	118	150
B (DIN 2633)	80	100	125
C (DIN 2633)	80	100	125
Ø D	M 140x2	M 168x3	M 205x3
F	400	460	530
H	25	30	15
Ø J	251	302,5	364
Ø KG7/h8	114	150	180
M	195	230	260
N	108,5	129	121,5
O	30	35	40
P	245	285	325
R	157	187	216,2
S	31,5	35,5	35
Ø WG7/e8	75	88	110
X	45	50	60
Z	450	525	605
GB	26	30	30
Weight (kg)	92	143	245

S Specifications and Spare Parts Series DX / DXS

8. Spare parts

8. Spare parts

8.1 DX1 + DXS1, DX2 + DXS2, DXR2 + DXSR2, DN 10 – 80

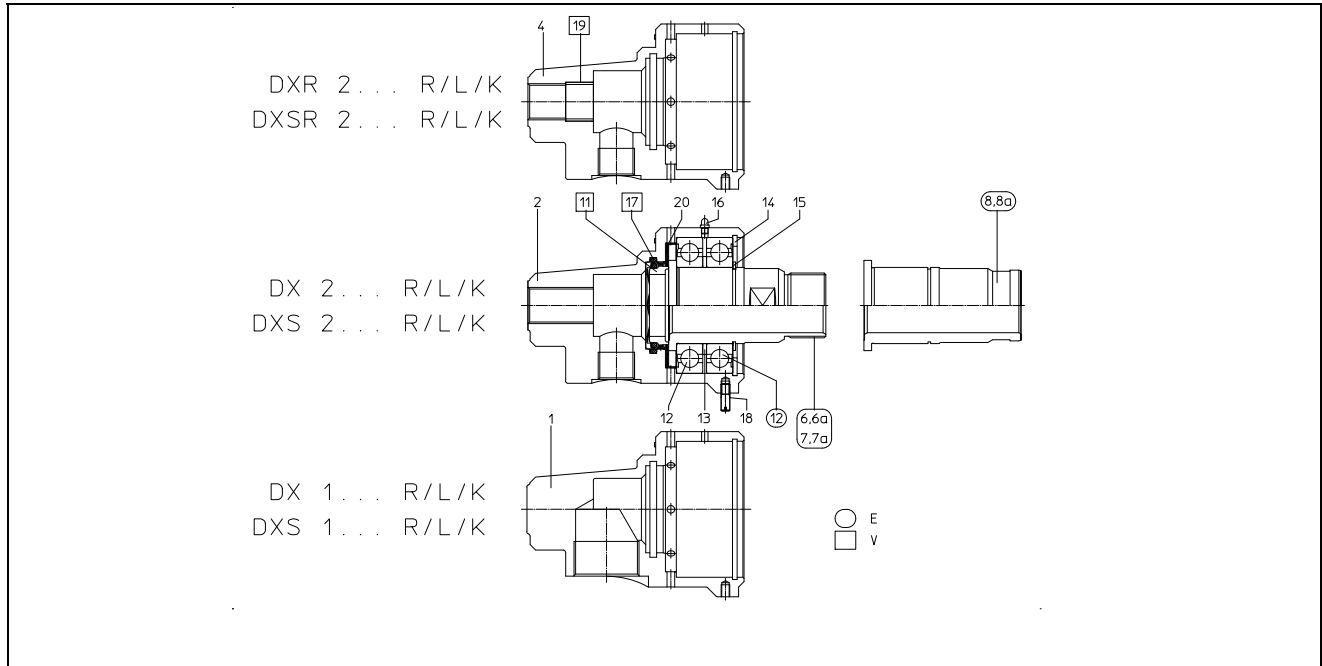

		E Spare part		V Wearing part						
DNmm	E V	10	15	20	25	32	40	50	65	80
1	Housing 1	1106010	1106060	1106110	1106160	1106210	1106260	1106310	1106360	1106410
2	Housing 2	1106011	1106061	1106111	1106161	1106211	1106261	1106311	1106361	1106411
4	Housing R2	—	1106062	1106112	1106162	1106212	1106262	1106312	1106362	1106412
6	Rotor R	E 1106015	1106065	1106115	1106165	1106215	1106265	1106315	1106365	1106415
6a	Rotor SR	E 1106015-023	1106065-023	1106115-023	1106165-023	1106215-023	1106265-023	1106315-023	1106365-023	1106415-023
7	Rotor L	E 1106016	1106066	1106116	1106166	1106216	1106266	1106316	1106366	1106416
7a	Rotor SL	E 1106016-023	1106066-023	1106116-023	1106166-023	1106216-023	1106266-023	1106316-023	1106366-023	1106416-023
8	Rotor K	E 1106017	1106067	1106117	1106167	1106217	1106267	1106317	1106367	1106417
8a	Rotor SK	E 1106017-022	1106067-022	1106117-022	1106167-022	1106217-022	1106267-022	1106317-022	1106367-022	1106417-022
11	Rotating mechanical seal	V 1501010-001	1501015-001	1501020-001	1501025-001	1501035-001	1501040-001	1501055-001	1501070-001	1501085-001
12	Deep groove ball bearing	E 3510200	3510201	3510202	3510203	3510204	3510205	3510206	3510207	3510208
13	Support disk	3510215	3510216	3510217	3510218	3510219	3510220	3510221	3510222	3510223
14	Locking ring, circlip	3501220	3501232	3501222	3501223	3501221	3501206	3501207	3501237	3501238
15	Locking ring, circlip	3501000	3501001	3501002	3501003	3501014	3501023	3501024	3501026	3501006
16	Lubrication nipple	3500918	3500918	3500918	3500918	3500918	3500918	3500918	3500918	3500918
17	O-ring	V 3511875	3511876	3511877	3511878	3511879	3511880	3511881	3511882	3511883
18	Set screw	3500675	3500675	3500675	3500676	3500676	3500677	3500677	3500678	3500678
19	Slide bearing	V —	3510502	3510504	3510506	3510501	3510509	3510512	3510514	3510523
20	Retainer ring	—	—	—	—	—	—	3509066	1106373-381	1106423-390

S Specifications and Spare Parts Series DX / DXS

8. Spare parts

82

DXSB2, DN 50 – 80

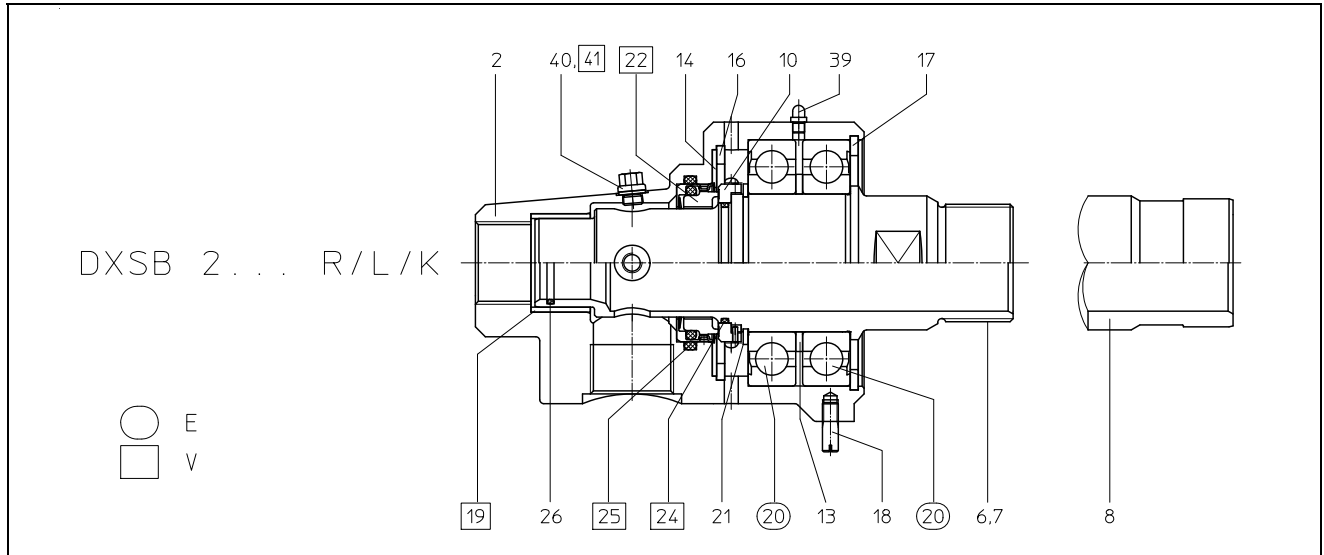

	E Spare part	V Wearing part			
		DNmm	50	65	80
2	Housing		1106312-273	1106362-248	1106412-273
6	Rotor R		1105486-236	1105561-275	1105636-275
7	Rotor L		1105487-236	1105562-275	1105637-275
8	Rotor K		1105488-276	1105563-247	1105638-276
10	Counter ring	E	1105502-278	1105577-246	1105652-278
13	Support disk		3510221	3510222	3510223
14	Holding disk		1106323-051	1106373-245	1106423-264
16	Locking ring, circlip		3501235	3500873	3500693
17	Locking ring, circlip		3501207	3501237	3501238
18	Set screw		3500677	3500678	3500678
19	Slide bearing	V	3510514	3510523	3510525
20	Deep groove ball bearing		3510206	3510207	3510208
21	Locking ring, circlip		3501024	3501026	3501006
22	Rotating mechanical seal	V	1501055-001	1501070-001	1501085-001
24	O ring for item 10	V	3511752	3511720	3511894
25	O ring for item 22	V	3511881	3511882	3511883
26	O ring for rotor	V	3511947	3511930	3511946
39	Lubrication nipple		3500918	3500918	3500918
40	Screw plug		3500660	3500660	3500660
41	Sealing ring	V	3502130-011	3502130-001	3502130-001

S Specifications and Spare Parts Series DX / DXS
8. Spare parts

8.3 DXS 1, DN 100 – 150

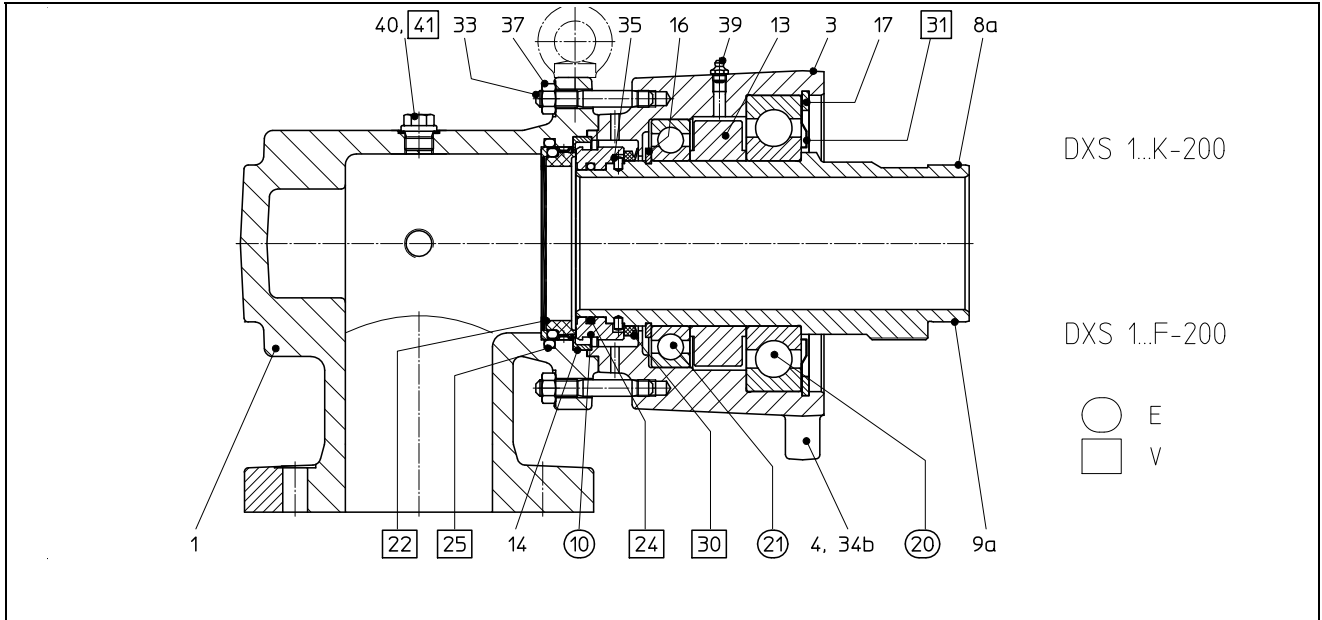

E Spare part V Wearing part

8.4 DXSB 2, DN 100 – 150

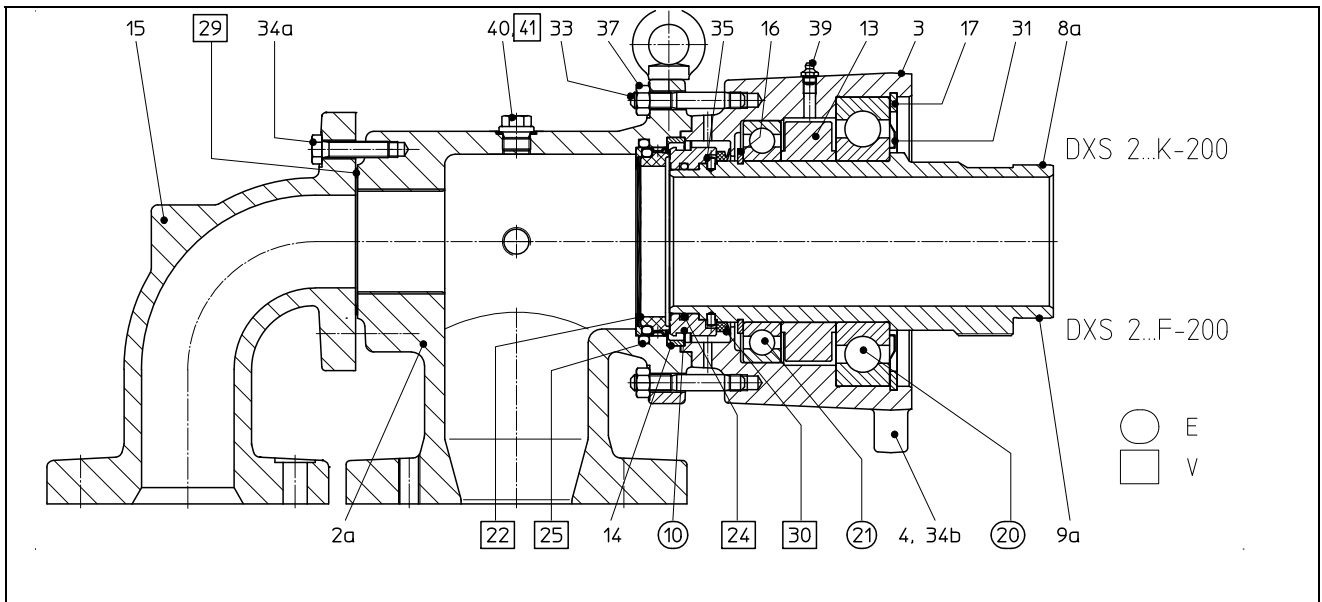

E Spare part V Wearing part

S Specifications and Spare Parts Series DX / DXS

8. Spare parts

8.5 DXSB 2, DN 100 – 150

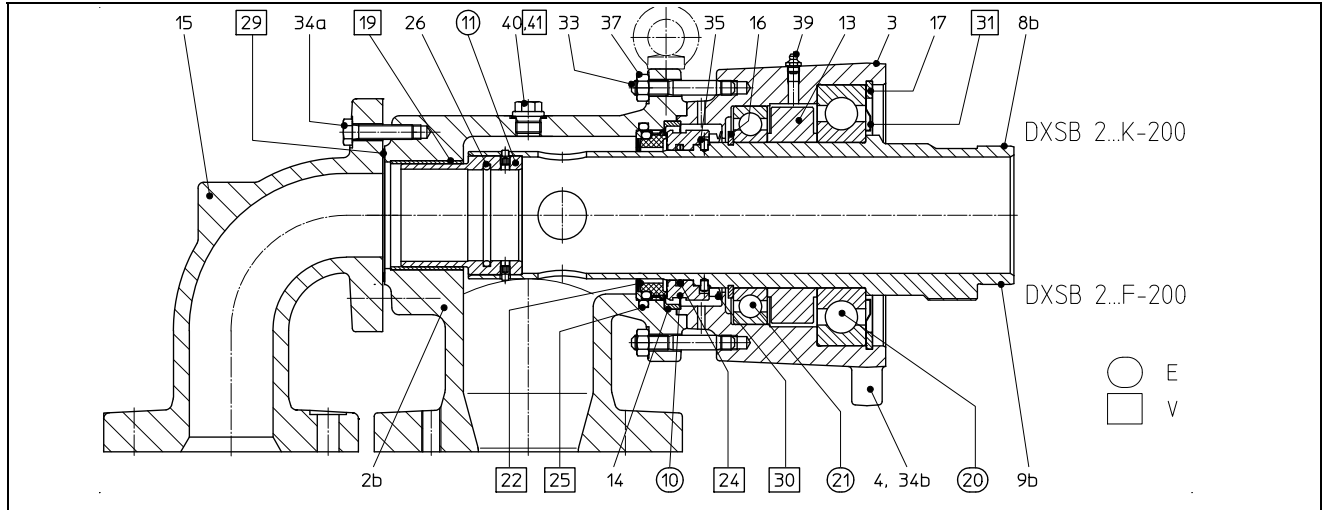

E Spare part

V Wearing part

	DNmm	E/V	100	125	150
1	Housing 1		1105700-393	1105775-281	1105850-134
2a	Housing 2		1105701-522	1105776-419	1105851-238
2b	Housing B2		1105701-390	1105776-285	1105851-133
3	Bearing housing		1105706-388	1105781-284	1105856-135
4	Anti-rotation fork				1105893
8a	Rotor K 1,2		1105717-383	1105792-279	1105867-138
8b	Rotor KB2		1105713-382	1105788-278	1105863-139
9a	Rotor F 1,2		1105718-523	1105793-420	1105868-239
9b	Rotor FB2		1105714-524	1105789-421	1105864-240
10	Counter ring	V	1105727-385	1105802-274	1105877-130
11	Rotor bushing complete	V	1105721-387	1105796-277	1105871-142
13	Spacer		1105732-384	1105807-275	1105882-140
14	Holding disk		1105733-386	1105808-276	1105883-141
15	Elbow		1105735-392	1105810-283	1110739
16	Locking ring, circlip 1		3501007	3501029	3501028
17	Locking ring, circlip 2		3501240	3501243	3501242
19	Slide bearing	V	3510536	3510493-001	3510495-001
20	Deep groove ball bearing 1	E	3510209	3510210	3510211
21	Deep groove ball bearing 2	E	3510015-011	3510083	3510018-011
22	Rotating mechanical seal	V	1501110-001	150113-001	1501170-001
24	O ring for item 10	V	3511770	3511740	3511743
25	O ring for item 22	V	3511693	3511899	3511893
26	O ring for item 11	V	3511825	3511826	3511692
29	Flat packing	V	3512092	3512271	3512255
30	shaft seal	V	3511984	3511987	3511747
31	Nilos ring	V	3509024	3509028	3509026
33	Stud bolt		3500263-007	3500271-007	3500271-007
34a	Hex screw		3500159-007	3500166	3500204-007
34b	Hex screw				3500084
35	Cylinder bolt		3500943-001	3500943-001	3500944-001
37	Hex nut		3500285-007	3500287-007	3500387-007
39	Lubrication nipple		3500913	3500913	3500913
40	Screw plug		3500655	3500655-007	3500655-007
41	Sealing ring	V	3502115-001	3502115-001	3502115-001