

Operating Instructions Maier Rotary Joints

Series DQ

B-DQ_en. Version 01.10.2008



Christian Maier GmbH & Co. KG Maschinenfabrik

Würzburger Str. 67-69 Postfach 16 09

D-89520 Heidenheim D-89506 Heidenheim

☎ +49 7321 317-0; 📠 +49 7321 317-139; 📧 vkd@maier-heidenheim.de; 🌐 www.maier-heidenheim.de



Operating Instructions Maier Rotary Joints

Series DQ

B-DQ_en - Version 01.10.2008

Contents

1	Safety	2
2	Design and function	3
3	Information on design and mounting	4
4	Transportation and storage	5
5	Mounting	6
6	Operation	9
7	Maintenance	10

Christian Maier GmbH & Co. KG reserves the copyright to this manual. The instructions, information and illustrations contained in this manual may not be copied in any way, neither partially nor completely. Neither may the instructions, information and illustrations be disclosed to third parties nor used to create competing products, systems or facilities or assist in such activities in any way

Operating Instructions Maier Rotary Joints

Series DQ

B-DQ_en - Version 01.10.2008

1 Safety

1.1 Intended use

Maier rotary joints are devices which may only be used to connect pressurized pipes to rotating pressurized systems. A typical example of such rotating pressurized systems are rollers through the inside of which flow liquids or steam in order to heat or cool down the rollers. Series DQ rotary joints can only be used for thermal oil. The limit values specified in the "Specifications and Spare Parts" part of the manual must not be exceeded in the application.

Never modify the rotary joint as this may cause danger. Install, operate and maintain the rotary joint only as described in these operating instructions. We shall not be liable for any damage and interruption whatsoever caused by failure to adhere to the operating instructions.

These operating instructions do not contain all information important for the safe operation of the unit. Always comply with all national and local regulations applicable at the installation site as well as all regulations concerning the prevention of accidents.

Use only genuine Maier spare parts or Maier-approved standard norm parts for repairs. If you use other parts, this may have adverse effects on the safety of the unit.

1.2 Requirements concerning installation and maintenance staff as well as operators

Only staff that has read and fully understood these operating instructions and that is fully aware of the dangers resulting from the unit as well as the appropriate safety precautions may work with Maier rotary joints. Such staff must have at least the knowledge of a trained locksmith or industrial mechanic who has experience with pressurized components.

1.3 Dangers



Warning!

If you touch hot parts or come into contact with hot liquids escaping under high pressure, this may result in dangerous burns.

⇒ Mount a protective cover to the rotary joint that prevents direct contact with hot medium and safely retains escaping medium.



Warning!

If the rotary joint blocks and rotates along with the roller, hoses can be torn off and hot liquids may escape under high pressure.

⇒ Observe the design and mounting information in chapter 3.

Monitor the rotary joint by means of a torque sensor and a vibration sensor.

Ensure that the unit is regularly maintained as per chapter 7.

1.4 Safety precautions

Always observe the following safety precautions for the operation of the unit:

- DQ, DQT and DQTX rotary joints may only be operated with a properly working cooling unit.
- DQL rotary joints do not need a cooling unit but must be lubricated (see 7.2 on page 10).

Operating Instructions Maier Rotary Joints

Series DQ

B-DQ_en - Version 01.10.2008

2 Design and function

2.1 Components

- B, C Housing connections for the medium. Only one housing connection in the case of mono-flow (single-passage) version.
- D Sealing element (flat packing or O ring)
- F Flange (K flange with inner ring, screwed flange or fixed flange) for mounting to roller
- G Housing
- I Optional inner pipe for duo (dual-passage) version, e.g. rotating along with rotor
- L Rotor, rotates along with roller
- R Anti-rotation fork
- S Sensor plug for bearing monitoring
- QE Inlet quench medium (for DQ, DQT, DQTX)
- QA Outlet quench medium (for DQ, DQT, DQTX)
- W Roller

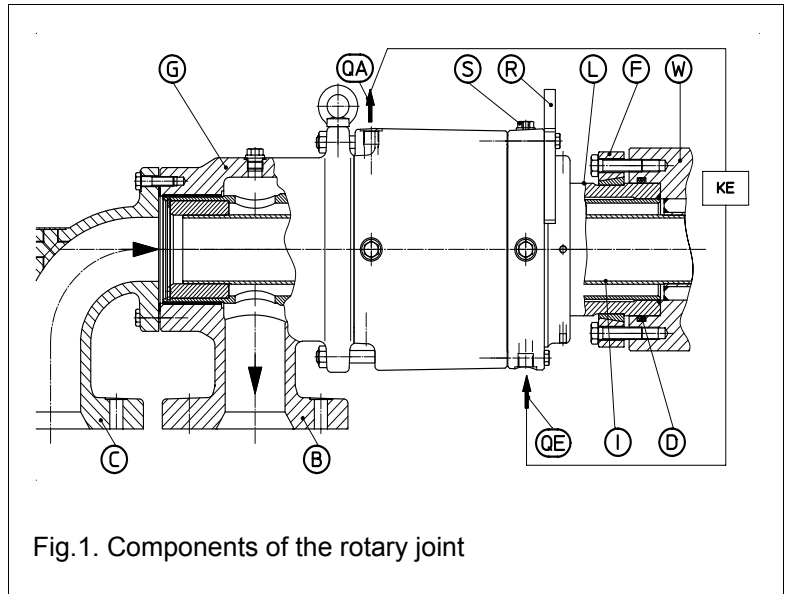

Fig. 1. Components of the rotary joint

2.2 Function

The rotary joint is mounted to the rotating roller "W" by means of flange "F". Sealing element "D" seals the unit. The medium enters the rotary joint via the stationary housing "G" of the rotary joint and flows into the roller. In the case of duo versions, inlet and outlet of the medium via the same rotary joint. In such a case, a second flow channel is created by means of an inner pipe "I", arranged centrally with reference to the rotating rotor "L". The stationary housing is supported by means of anti-rotation fork "R". Sensor plug "S" is provided for the installation of a vibration pickup to enable monitoring of the bearings in the rotary joint.

Series DQ rotary joints are suitable for supplying thermal oil up to 400°C (752°F) and for speeds of rotation of up to 2000 min⁻¹(mpr). These applications are typical in coating and laminating systems, paper, non-woven and textile calendars, dryers, rotation reactors.

If hot thermal oil comes into contact with the oxygen in the air, chemical reactions such as cracking and coking result. This damages seals; oil and oil vapor escape. The DQ system separates the air oxygen from the hot oil by means of quench oil - same thermal transfer medium as in the main circuit. In addition, the quench medium lubricates the seals and the bearing of the rotary joint.

If more than one rotary joint is supplied to a cooling unit, an oil distributor must be used which supplies each rotary joint with a sufficient volume of quench medium.

To return the quench medium, an additional cooling unit "KE" is used with versions DQ, DQT and DQTX. Version DQL does not require a cooling unit; the application limit is 250°C (482°F); the application limit of nominal diameter 50 is 200°C (392°F).

Operating Instructions Maier Rotary Joints

Series DQ

B-DQ_en - Version 01.10.2008

3 Information on design and mounting



Caution!

Damage to components caused by vibration and heat expansion.

⇒ **Use only flexible hoses to connect the unit!**

- For the connection of the hot oil and the cooling oil, use flexible hoses between the supply system and the rotary joint housing. This compensates for heat expansion and vibrations.
- Never apply torsional, tensile or pressure loads to metal hoses. Observe the minimum bending radius quoted by the manufacturers.
- Use flat packings made of pure graphite to securely seal flange connections.
- Only operate the rotary joint with a sufficiently dimensioned torque support. The support element must allow for axial and radial movements of the housing.
- In addition, install a torque monitoring system with connection to the emergency shutdown system in order to avoid consequential damages resulting from bearing damage. If the torque monitoring system is activated, the rotation of the roller should be stopped immediately and the supply of the thermal oil should be interrupted upstream of the metal hoses.
- If the bearings in the rotary joint are to be monitored, connect a vibration pickup to sensor plug "S" (female thread M6x1; see fig. 1 on page 3).
- Center the inner pipe and the roller as well as the rotary joint. Run-out and axial tension of the inner pipe will lead to malfunctions of the rotary joint.
- For smooth operation of rotary joint ensure concentricity and minimum run-out tolerance at roller or intermediate flange.

3.1 Overview for preparing mounting

- | | |
|--------------------|-------------------------------------|
| 1 | Rotary joint series DQ |
| 2 | Flange, e.g. KF... |
| 3 | Inner ring IR... with flange KF |
| 4 ¹⁾ | Sealing element (e.g. flat packing) |
| 5a/ | Screw connection for supply/ |
| 5b ²⁾ | alternatively hose for supply |
| 6a/ | Screw connection for return/ |
| 6b ²⁾ | alternatively hose for return |
| 7 | Metal hose E...CC |
| 8 | Flat packing |
| 9 ²⁾ | Cooling unit KE... |
| 10 ²⁾³⁾ | Quench oil distributor |

¹⁾ Depending on the roller design, other sealing elements are possible

²⁾ Not required for DQ.

³⁾ Only in case of connection of several rotary joints to one cooling unit.

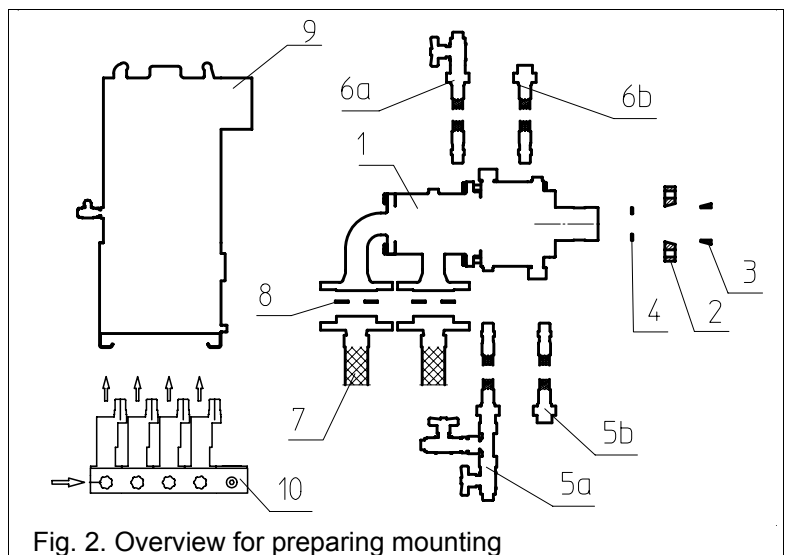

Fig. 2. Overview for preparing mounting

Operating Instructions Maier Rotary Joints

Series DQ

B-DQ_en - Version 01.10.2008

3.2 Design of the cooling oil circuit

If you use a Maier cooling unit, observe the information provided in the corresponding operating instructions. In all other cases, observe the information provided in the operating instructions of the corresponding manufacturer. The cooling oil circuit must meet the following requirements:

- Install the cooling unit in such a way as to assure that
 - the cooling oil pipes have a maximum total length of 25 m (82 ft) (please contact the manufacturer if this is impossible)
 - the operating side is easily accessible
 - contact with hot surfaces that are not insulated is impossible
 - escaping oil is collected (e.g. by an oil collector below the unit)
- If several rotary joints are connected to a cooling unit, connect the rotary joints in parallel and use an oil distributor. Refer to the part "Specifications and Spare Parts" for information on the required oil flow.
- The following operating parameters should be met and monitored to ensure proper operation of the rotary joint:
 - Min. cooling oil flow V1 according to "Specifications and Spare Parts" (remedy problems within 10 minutes; If this is impossible, immediately shut down the cooling unit and the rotary joint in order to prevent damage to the rotary joint and prevent blocking). It is best to integrate the sensor in the oil distributor. Monitor each rotary joint individually.
 - Max. cooling oil temperature (problems must be remedied within 30 minutes; if this is impossible, shut down the cooling unit and the rotary joint in order to prevent damage to the rotary joint and blocking). Monitor the temperature at a central point in the cooling unit.
 - Cooling oil filtering (problems must be remedied within 3 days; if this is impossible, shut down the cooling unit and the rotary joint in order to prevent damage to the rotary joint and blocking).
 - Min. and max. cooling oil level. This allows you to draw conclusions on the status of the rotary joint:
 - Min. level = primary seal with internal leak or secondary seal with external leak.
 - Max. level = primary seal with internal leak

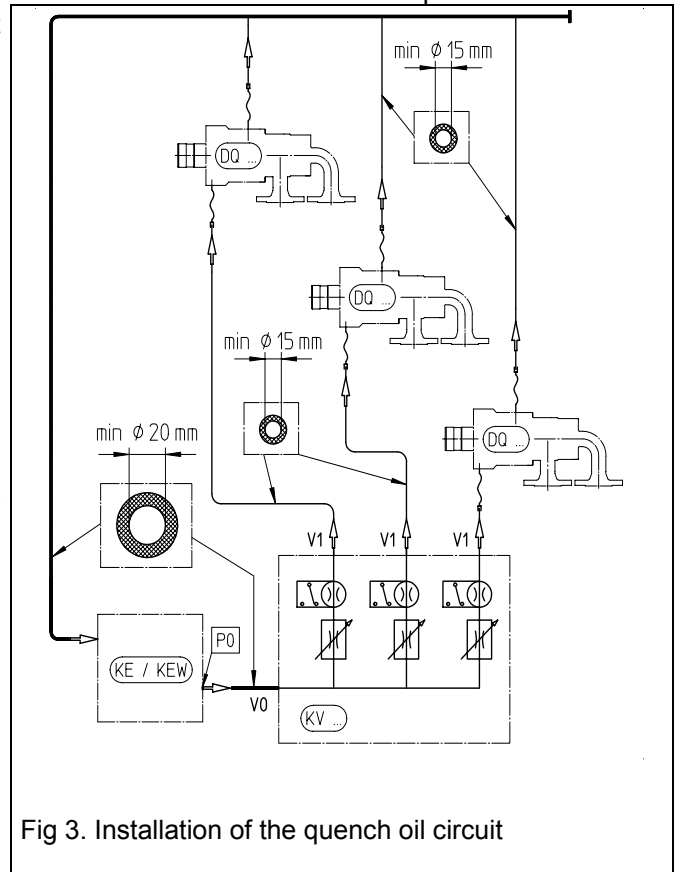

Fig 3. Installation of the quench oil circuit

4 Transportation and storage

- Use suitable lifting gear to transport rotary joints weighing more than 25 kg (55lb). Use a suitable ring bolt (see "Specifications and Spare Parts").
- Store the rotary joints only in the original package.
- Make sure the storage conditions specified in "Specifications and Spare Parts" are met.
- If the rotary joint is shut down for a longer period of time or stored, protect it against corrosion. We recommend filling the complete bearing chamber with clean oil (e.g. thermal oil or corrosion protection oil) via the cooling oil connections.
- If the rotary joint itself or the facility in which the rotary joint is installed is to be preserved, make sure the preservation agent and the seals of the rotary joint are compatible.

Operating Instructions Maier Rotary Joints

Series DQ

B-DQ_en - Version 01.10.2008

5 Mounting

5.1 Adapting the hot oil connections

Connections B / C can be turned in increments of 45°. To do so:

- Loosen the fastening screws.
- Turn the housing parts to the desired position.
- Make sure not to damage flat packings 360 and 370!
- Tighten screw connections 360 and 370 as per table 3 in the "Specifications and Spare Parts" part of the instruction manual

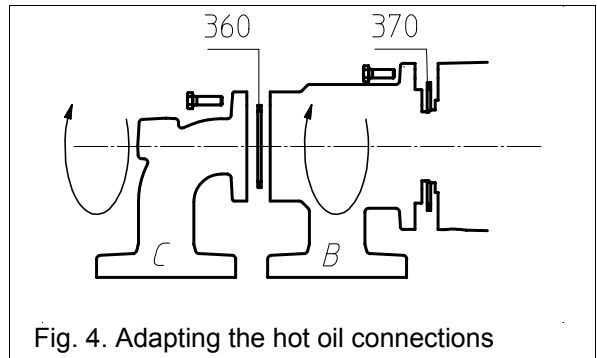

Fig. 4. Adapting the hot oil connections

5.2 Adapting the cooling oil connections - DQ, DQT, DQTX only

The cooling oil inlet "IN" may be in any position in the A-A plane.

In the B-B plane, the cooling outlet must always be at the highest point. If not, you must de-aerate the system every time you start it. Changing the oil outlet "OUT":

- Change the position of plug 265 in increments of 4 x 90°. This assures sufficient safety for de-aeration, even if the rotary joint is in an intermediate position.
- In case of bearing monitoring with vibration pickup: Interchange sensor plug "S" with M6x1 blind hole with any other plug 265 at planes A-A or B-B.

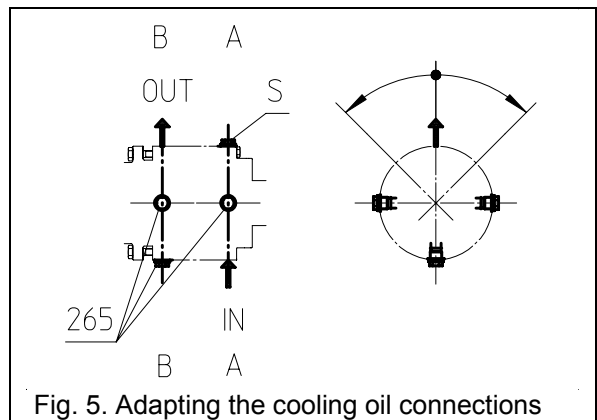

Fig. 5. Adapting the cooling oil connections

5.3 Adapting the leakage connection - DQL only

Series DQL rotary joints feature a relief connection (4 connections with G thread) for leakage at the seal in plane B-B. Leakage should be discharged from the rotary joint to a safe point:

- If the rotary joint is mounted *horizontally*: use the bottom housing connection to discharge leakage. Ensure a continuous hydraulic slope so that the leakage may be discharged without backpressure. It may be necessary to interchange the plugs.
- If the rotary joint is mounted *vertically*: you may use any housing connection.

5.4 Adapting the anti-rotation fork

- Support the rotary joint with anti-rotation fork 180. Adapt the position in increments of 8 x 45°.
- Dismount clamping screws 410 and 420 and reposition them.
- Always make sure that the housing parts are tightly held by at least two screws – danger of tension and damage to the seal.

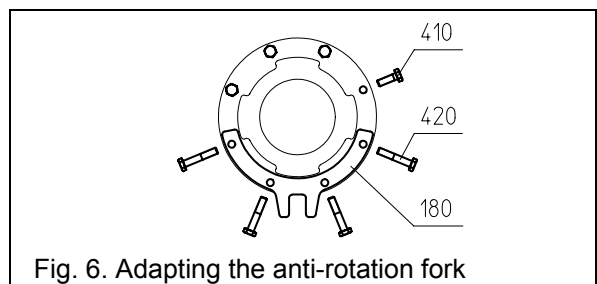

Fig. 6. Adapting the anti-rotation fork

Operating Instructions Maier Rotary Joints

Series DQ

B-DQ_en - Version 01.10.2008

5.5 Mounting the rotary joint to the roller

- Mount rotary joint 1 to roller:
as per drawing A with K flange and inner ring 3
as per drawing B with screwed flange 4 or
as per drawing C with fixed flange 5
- Seal with O ring 6, flat packing 7 or another suitable
sealing element.
- Fasten the rotary joint with screw 8 or stud bolt 9 and
nut 10.
- Clean sealing surfaces DF, apply mounting paste and
place the sealing element into roller W.
Recommended material for flat packing:
pure graphite with metal insert.
- Rotary joint with inner pipe: screw or plug the inner pipe
into the rotary joint, depending on the version. For easier
mounting of the rotary joint, it is recommended to
loosen the elbow at connection C. Do not damage the
seal!
- Mount K flange 2 with screws over rotor 80 and place
inner ring 3 into rotor groove or screw flange 4 to rotor
90. Mount stud bolts 9.
- Lift the rotary joint at the suspension point with a ring
bolt and insert it into the centering unit of the roller.
Versions with inner pipe: the inner pipe must be centered
with reference to the rotary joint and the roller. If
you encounter resistance, check for correct position.
Run-out and axial tension cause malfunctions of the ro-
tary joint.
- Mount screws 8 and nuts 10.
- Maximum permissible torque for all screw connections
as per table 3 in "Specifications and Spare Parts".

Caution:

- When sealing with flat packing, do not fully tighten
the screws until you have aligned the rotary joint
as per section 5.6!
- Assure the minimum distance MA - otherwise
leakage will occur at the sealing element and the
rotary joint and the inner pipe will be damaged:
drawings A and B: $MA \geq 1 \text{ mm (0.04")}$
drawing C : $MA = 0 \text{ mm (0.00")}$

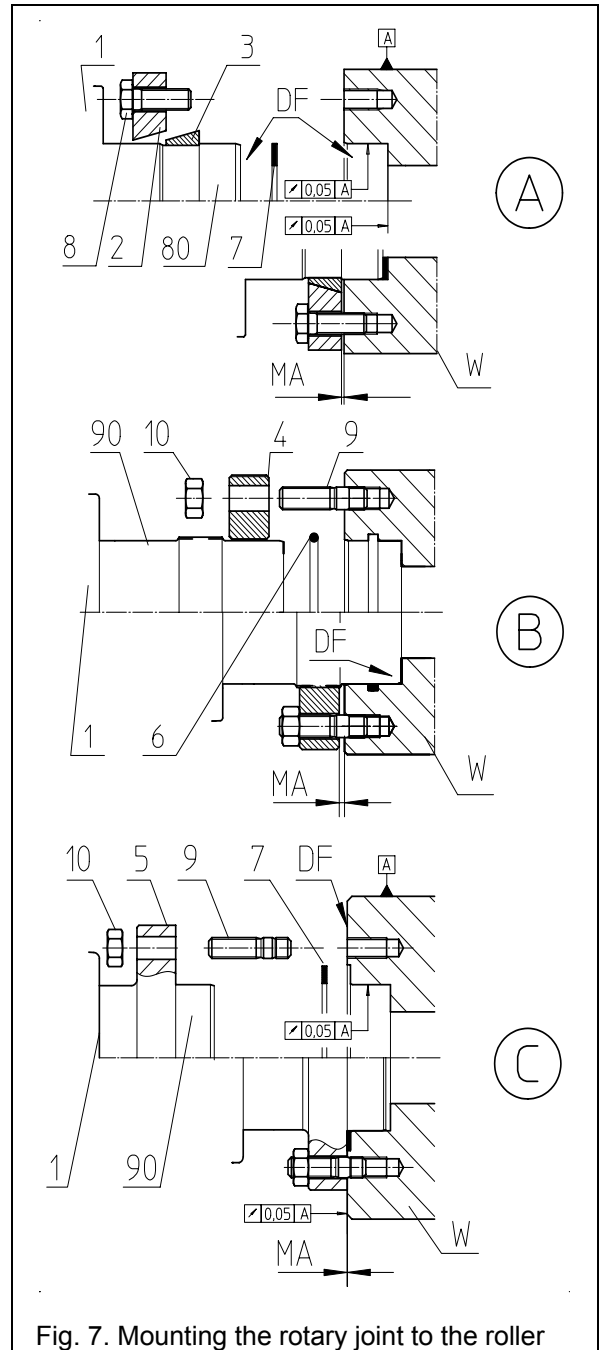

Fig. 7. Mounting the rotary joint to the roller



Note!
For smooth operation of rotary joint ensure concentricity and minimum run-out tolerance of roller.

Operating Instructions Maier Rotary Joints

Series DQ

B-DQ_en - Version 01.10.2008

5.6 Aligning the rotary joint

- Place dial gauge "M" from the idle machine frame "MG" onto the rotary joint.
- Rotate roller "W" until the dial gauge is at the bottom dead center UT. Mark the pointer position.
- Rotate roller until you reach the upper dead center "OT".
- Tighten the bottom screws "Su" until the dial gauge is in the center position.
- Repeat this alignment process until you reach the concentricity tolerance specified in the table below.
- Tighten the screws with torque specified in table 3 in "Specifications and Spare"!

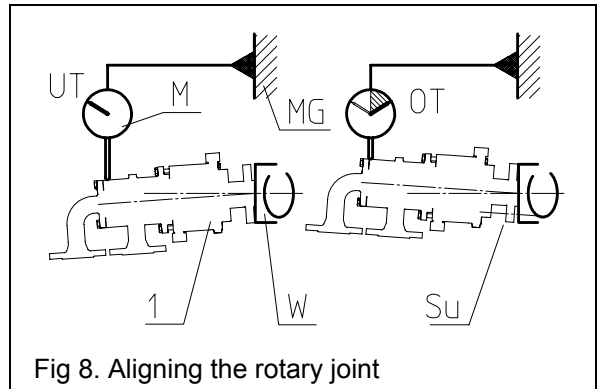

Fig 8. Aligning the rotary joint

Permissible concentricity tolerance

	n (min ⁻¹ / rpm)		
DN	≤ 100	≤ 400	> 400
25-50	±0.25 mm (±0.01")		
65-150	±0.1 mm (±0.004")		

5.7 Connecting the rotary joint



Caution!

Bearing damage due to overheating.

- ⇒ **DQ, DQT, DQTX: Never operate the rotary joint without cooling!**
- ⇒ **Never operate the unit beyond the application data specified in the section "Specifications and Spare Parts".**
- ⇒ **The rotary joint must never run dry.**

- Mount anti-rotation device 30 of the rotary joint housing. Mount the torque monitoring unit or, alternatively, the vibration pickup for bearing monitoring to the sensor connection "S".
- Connect the housing flanges "B" and "C" for the thermal oil:
- **DQ, DQT, DQTX:**
 - Connect the cooling oil circuit as per section 3.2 and according to the mounting instructions for the cooling unit.
 - Connect the cooling oil supply to connection "QE" and the cooling oil return to connection "QA"
- **DQL:** connect the bore hole for the leakage
 - Filter the thermal oil since the service life of the seal depends to a large degree on the concentration of solid matter in the oil.

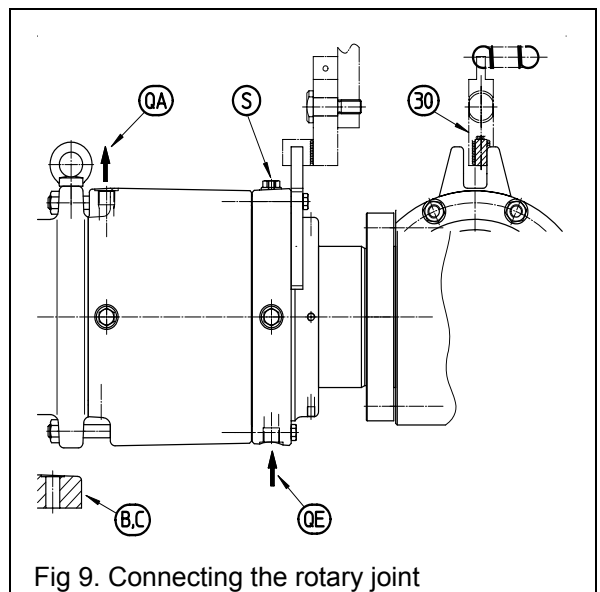

Fig 9. Connecting the rotary joint



Note!

Refer to the "Specifications and Spare Parts" section for information on the lubricants to be used.

Observe the information in section 3!

Operating Instructions Maier Rotary Joints

Series DQ

B-DQ_en - Version 01.10.2008

6 Operation

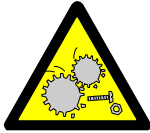

Caution!

Danger of damage if the rotary joint is not operated as per instructions.

- ⇒ **Never operate the unit beyond the application data specified in the section "Specifications and Spare Parts".**
- ⇒ **Observe the application limitations specified in section 1.1 on page 2!**

6.1 Observe and check during operation

Check the following during operation:

- Check the centric arrangement of the rotor and the roller driver. The radial deflection at the housing in the area of the elbow must not exceed 0.1 mm (0.004"). Measure with dial gauge from idle machine frame to rotary joint. Refer to section 5.6 for further details.
- Check the quench oil circuit for leaks and effectiveness. Also check the volume flow monitoring system for the circuit (cooling unit or oil distributor).
- Check the cooling unit for effectiveness according to the separate instructions.
- Check the quality of the thermal oil and the quench oil.

6.2 Troubleshooting

Problem	Reason	Repair
Cooling circuit does not operate properly	Cooling medium low, leakage, failure of the pump or the quench oil cooling.	Check the level and flow. The problem must be remedied within 30 minutes in order to prevent damage to the rotary joint! Refer to the information in the instructions for the KE/KEW cooling unit.
Leakage at the sealing point between <ul style="list-style-type: none"> • Housing/bearing housing (item 360) or • Elbow/housing (item 370) or • Rotor/roller 	<ul style="list-style-type: none"> • Flat packing damaged • Screw torque of connection insufficient 	<ul style="list-style-type: none"> • Replace flat packing during the next planned shutdown In the case of considerable leakage, immediately shut down the rotary joint. • Tighten the screws with the correct torque as per table 3 in "Specifications and Spare parts". Do not overload screws as this will destroy them. Immediately replace overloaded screws!



Operating Instructions Maier Rotary Joints

Series DQ

B-DQ_en - Version 01.10.2008

7 Maintenance

7.1 Safety during maintenance

Only staff that has read and fully understood these operating instructions and that is fully aware of the dangers resulting from the unit as well as the appropriate safety precautions may work with Maier rotary joints. Such staff must have at least the knowledge of a trained locksmith or industrial mechanic who has experience with pressurized components.

Only perform work on the rotary joint when the machine/system is off.

Allow the rotary joint to cool down before you take up work or wear safety equipment to protect against the heat.

Always wear safety glasses when performing work on the rotary joint to protect against escaping medium.

Use only genuine Maier spare parts or Maier-approved standard norm parts for repairs. If you use other parts, this may have adverse effects on the safety of the unit.

Maier offers on site service by experts. We can also train your service staff - just get in touch with us!

If you have to remove protective equipment to perform the work, refit such equipment when you are done and check it for proper operation.

Make sure to properly tighten all screws. It is recommended to regularly check and retighten screw connections as per section 7.2. This applies in particular to seals 360 and 370.

Always observe the safety information in chapter 1, page 2.

7.2 Maintenance plan

Interval	Activity	Explanations
As per section "Specifications and Spare Parts"	<u>Lubricate DQL</u> rotary joints, depending on the operating temperature.	Only use the lubricants listed in the section "Specifications and Spare Parts". Lubrication volumes depend on the nominal diameter of the rotary joint (see section "Specifications and Spare Parts").
6 weeks	Retighten the screw connections with a torque wrench - in particular at the seals, items 360 370 (see spare parts)	Use the torques shown in table 3 in the section "Specifications and Spare Parts". If retightening is only possible under operating conditions, the reduced torques for the respective temperatures apply. Exceeding the tightening torque will destroy the screw! In this case, the screw must be replaced.
8 weeks	Check the quench oil and thermal oil circuits as well as the connections for leaks.	
	Check the relief connections of the rotary joint for leaks.	Slowly increasing leakage indicates seal failure.
	Check the quality of the quench oil and the thermal oil and record the values.	
	Check the lubrication oil unit.	Refer to separate instructions KE/KEW
	Check the quench oil level.	Decreasing levels indicate leaks in the quench supply system, increasing levels indicate leaks at the mechanical seal.
Every 24 months	Check and replace all bearings and seals.	By Maier customer service

Specifications and Spare Parts

Series DQ

S-DQ_en - Version 01.10.2008

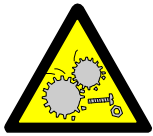

Caution!

Danger of damage if the rotary joint is not operated as per instructions.

- ⇒ The specifications listed in this part of the instruction manual are binding.
- ⇒ Never operate the unit beyond the application data specified!
- ⇒ Use only approved media and lubricants!
- ⇒ We shall not be liable for any damage whatsoever caused by failure to adhere to limit values or use of unsuitable media and lubricants!

Table 1: Application data

	DQL	DQ	DQT	DQTX	
Version	1, B2	1, B2	1, B2	1, B2	
Nominal diameter DN [mm]	25-150	25-150	25-150	25-150	
Nominal diameter DN [inch]	1-6	1-6	1-6	1-6	
Additional equipment for cooling and lubrication	--	KE / KEW	KE / KEW	KE / KEW	
Medium	Thermal oil (mineral oil based or synthetic) filtered with 0.25 mm (0.00984") filter fineness				
Temperature	max. °C max. °F	250 ^{*1} 482	300 572	350 662	400 752
Pressure PN	max bar max. psi	10 145	10 145	10 145	13 189
Speed	max. min⁻¹ max. rpm	<u>55.000</u> ^{*2} DN (mm)	<u>100.000</u> DN (mm)	<u>100.000</u> DN (mm)	<u>100.000</u> DN (mm)

*1 At nominal diameter 50: 200 °C (392 °F).

*2 Speed depends on temperature - greater than 200 °C (392°F): contact manufacturer.

Avoid operating the unit under conditions involving several maximum values attained at the same time.

Table 2: Transportation and storage

Storage temperature	15 °C to 30 °C 59 °F to 86 °F	
Humidity	65 %	
Preservation	none; check compatibility with seal materials, if necessary	
Fastening		
Nom. diameter mm	Nom. diameter inch	Thread diameter for ring bolt
25 - 40	1 – 1½	not applicable
50 - 65	2 – 2½	M 10
80 - 200	3½ - 8	M 12



Specifications and Spare Parts

Series DQ

S-DQ_en - Version 01.10.2008

Table 3: Torque for fastening screws in Nm (ft-lbf) at friction in thread and heat seat $\mu = 0,14$ and ...

Property class 5.6 at screw temperature						
Size	20°C 68°F	100°C 212°F	150°C 302°F	200°C 392°F	250°C 482°F	300°C 572°F
M 6	4.0 (2.95)	3.6 (2.66)	3.4 (2.51)	3.1 (2.29)	2.9 (2.14)	2.7 (1.99)
M 8	10.0 (7.38)	9.0 (6.64)	8.5 (6.27)	7.9 (5.83)	7.3 (5.38)	6.6 (4.87)
M 10	18 (13.28)	16 (11.80)	15 (11.06)	14 (10.33)	13 (9.59)	12 (8.85)
M 12	37 (27.29)	33 (24.34)	31 (22.86)	29 (21.39)	26 (19.18)	24 (17.70)
M 16	90 (66.38)	81 (59.74)	76 (56.05)	71 (52.37)	65 (47.94)	60 (44.25)
M 20	175 (129.07)	158 (116.53)	148 (109.16)	138 (101.78)	127 (93.67)	116 (85.56)
Property class 8.8 at screw temperature						
Size	20°C 68°F	100°C 212°F	150°C 302°F	200°C 392°F	250°C 482°F	300°C 572°F
M 6	10.0 (7.38)	9.3 (6.86)	8.9 (6.56)	8.4 (6.20)	8.0 (5.90)	7.5 (5.53)
M 8	24.0 (17.70)	22.3 (16.45)	21.3 (15.71)	20.3 (14.97)	19.1 (14.09)	18.0 (13.28)
M 10	48 (35.40)	45 (33.19)	43 (31.72)	41 (30.24)	38 (28.03)	36 (26.55)
M 12	82 (60.48)	76 (56.05)	73 (53.84)	69 (50.89)	65 (47.94)	62 (45.73)
M 16	206 (151.94)	192 (141.61)	183 (134.97)	174 (128.34)	164 (120.96)	155 (114.32)
M 20	400 (295.02)	372 (274.37)	355 (261.83)	338 (249.30)	319 (235.28)	300 (221.27)

Specifications and Spare Parts

Series DQ

S-DQ_en - Version 01.10.2008

Table 4: Bearing lubrication and cooling

Lubricant	DQL	TURMOTEMP LP 5002 by Lubricant Consult GmbH (www.lubcon.com) <u>Caution:</u> Other lubricants only after consultation with your lubricant supplier. We shall not be liable in any way whatsoever if lubricants other than the lubricants approved by us are used.										
	DQ, DQT	The best solution is to use the same oil as in the thermal oil circuit. Required quality: - clean, free from solid matter - viscosity at least 15 mm ² /s at 40 °C (104 °F) - temperature resistance at least 150 °C (302 °F)										
	DQTX	As per separate specification. This specification is agreed upon with us when the order is placed.										
Volume		DN [mm] DN [inch]	25 1	32 1¼	40 1½	50 2	65 2½	80 3½	100 4	125 5	150 6	200 8
	DQL	Q grease [cm ³] Q grease [in ³]	11 0.67	11 0.67	16 0.98	10 0.61	16 0.98	19 1.16	24 1.46	36 2.20	90 5.49	-
	DQ, DQT	Q oil (V1) [l/min] ^{*1} [gal _{US} /min] ^{*1}	3.5 0.92	3.5 0.92	4 1.06	5 1.32	6 1.58	7 1.85	8 2.11	9 2.38	11 2.90	14 3.67
	DQTX		As per separate specification. This specification is agreed upon with us when the order is placed.									
			^{*1} If several rotary joints are operated via a single cooling unit, one oil distributor per rotary joint is required. It is recommended to evenly distribute the volume flow per rotary joint via the oil distributor. The minimum values specified must be adhered to.									
Lubrication intervals		up to 150 °C up to 302 °C			150 °C to 200 °C 302 °F to 392 °F			200 °C to 250 °C 392 °F to 482 °F				
	DQL	every 6 months			every 8 weeks			every 2 weeks				
	DQ, DQT, DQTX	These rotary joints are lubricated by the circulated cooling oil. Therefore, they do not require maintenance as long as there is no error condition at the cooling unit.										
Max. permissible temperature T _{max} for lubricant inlet		DN mm	DN inch		T _{max} (°C)		T _{max} (°F)					
	DQL	25-200	1 - 8		-		-					
	DQ, DQT				80		176					
	DQTX				65		149					

Specifications and Spare Parts

Series DQ

S-DQ_en - Version 01.10.2008

Outline drawing DN 25-40 (1" - 1½")

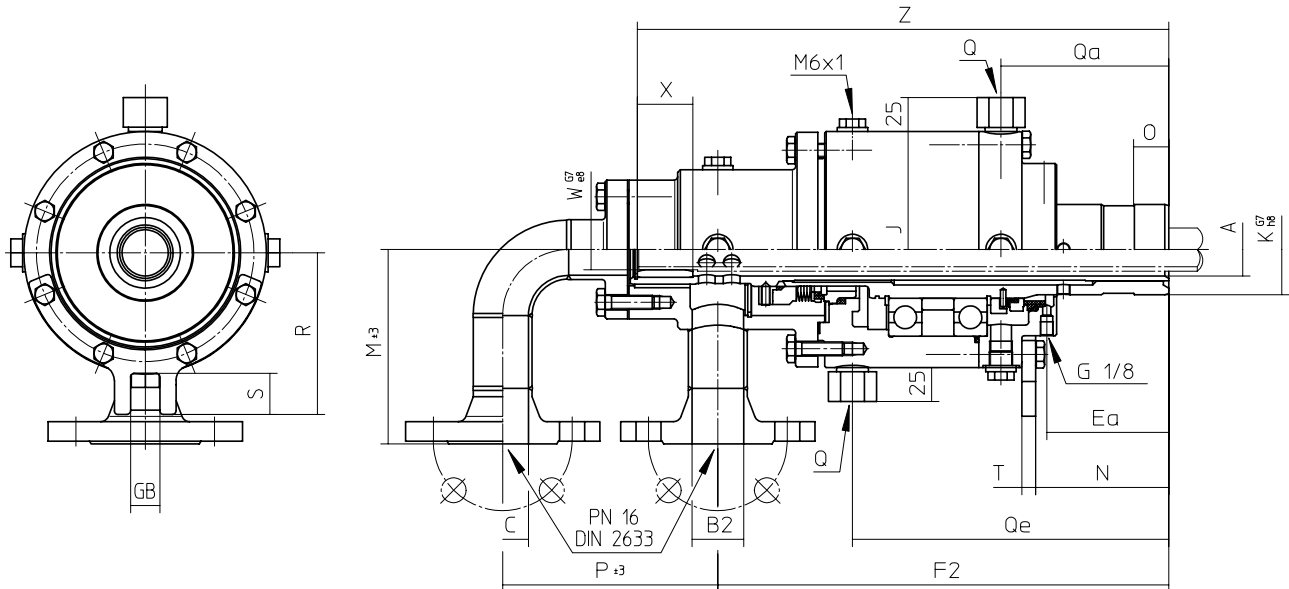

DN [mm]	25	32	40
DN [inch]	1	1¼	1½
Type	DQLB 225 K	DQLB 232 K	DQLB 240 K
Ordering no.	1110097	1110172	1110247
Type	DQB 225 K	DQB 232 K	DQB 240 K
Ordering no.	1110081	1110156	1110231
Type	DQTB 225 K	DQTB 232 K	DQTB 240 K
Ordering no.	1110091	1110166	1110241

φ A	25	32	38
B2	DN20	DN25	DN32
C	DN20	DN25	DN32
Ea	71	76	88
F2	280	285	325
φ J	150	150	170
φ K G7/h8	45	50	65
M ± 3	120	120	140
N	77	82	96
O	20	25	25
P ± 3	140	140	155
Q (4x90°)	G 1/2	G 1/2	G 1/2
Qa	100	105	121
Qe	183	188	228
R	102	102	120
S	24	24	25
T	10	10	10
φ W G7/e8	18	24	29
X	30	30	40
Z	325	330	383
GB	20	20	20
Weight kg	25	25	35
(lbs)	(55.12)	(55.12)	(77.16)

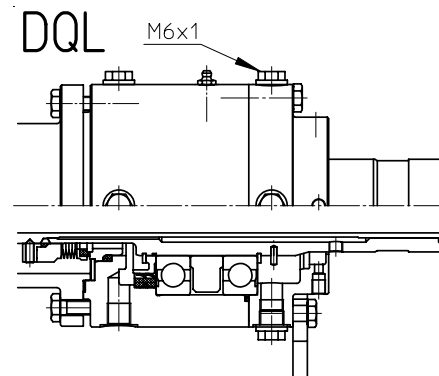



Specifications and Spare Parts

Series DQ

S-DQ_en - Version 01.10.2008

Outline drawing DN 50-150 (2" - 6")

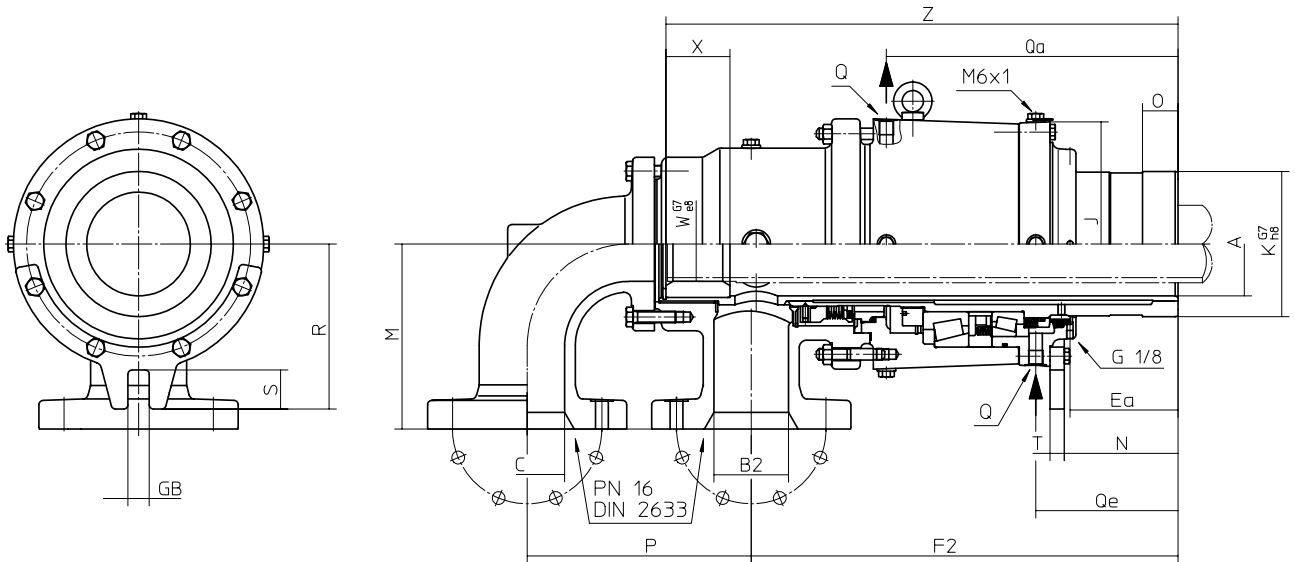

DN [mm]	50	65	80	100	125	150
DN [inch]	2	2½	3½	4	5	6
Type	DQLB 250 K-100	DQLB 265 K-100	DQLB 280 K-100	DQLB 2100 K-100	DQLB 2125 K-100	DQLB 2150 K
Ordering no.	1110322-100	1110397-100	1110472-100	1110547-100	1110622-100	1110697
Type	DQB 250 K-100	DQB 265 K-100	DQB 280 K-100	DQB 2100 K-100	DQB 2125 K-100	DQB 2150 K
Ordering no.	1110306-100	1110381-100	1110456-100	1110531-100	1110606-100	1110681
Type	DQTB 250 K-100	DQTB 265 K-100	DQTB 280 K-100	DQTB 2100 K-100	DQTB 2125 K-100	DQTB 2150 K
Ordering no.	1110316-100	1110391-100	1110466-100	1110541-100	1110616-100	1110691
φ A	50	66	81	99	119	146
B2	DN 40	DN 50	DN 65	DN 80	DN 100	DN125
C	DN 40	DN 50	DN 65	DN 80	DN 100	DN125
Ea	101	116	119,5	134,5	138,5	152
F2	400	425	455	502	560	600
φ J	186	204	234	265	310	352
φ K G7/h8	85	105	114	135	170	204
M	145	170	180	195	230	260
N	83	125	131,5	146,5	149	160
O	30	35	40	45	50	50
P	170	180	205	225	280	315
Q (4x90°)	G 1/2	G 1/2	G 1/2	G 1/2	G 1/2	G 1/2
Qa	277	308,5	325	362	401	410
Qe	124,5	154	164,5	179,5	189,5	200
R	115	130	155	177	205	232
S	23	25	36,5	55	50	55
T	10	10	15	15	15	20
φ W G7/e8	37	45	60	75	88	105
X	50	50	40	50	80	90
Z	460	500	535	587	676	720
GB	22	22	26	30	30	30
Weight kg	50	68	95	130	208	284
(lbs)	(110.23)	(149.91)	(209.44)	(286.60)	(458.56)	(626.11)

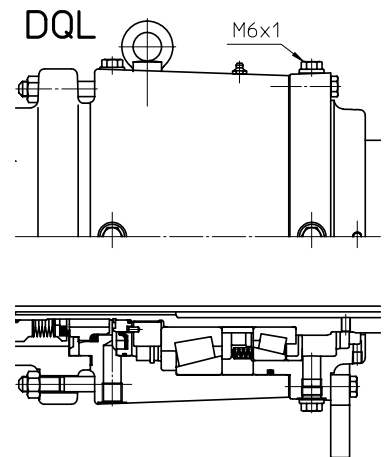

Specifications and Spare Parts

Series DQ

S-DQ_en - Version 01.10.2008

Spare parts DQ 25-40 (1" - 1½")

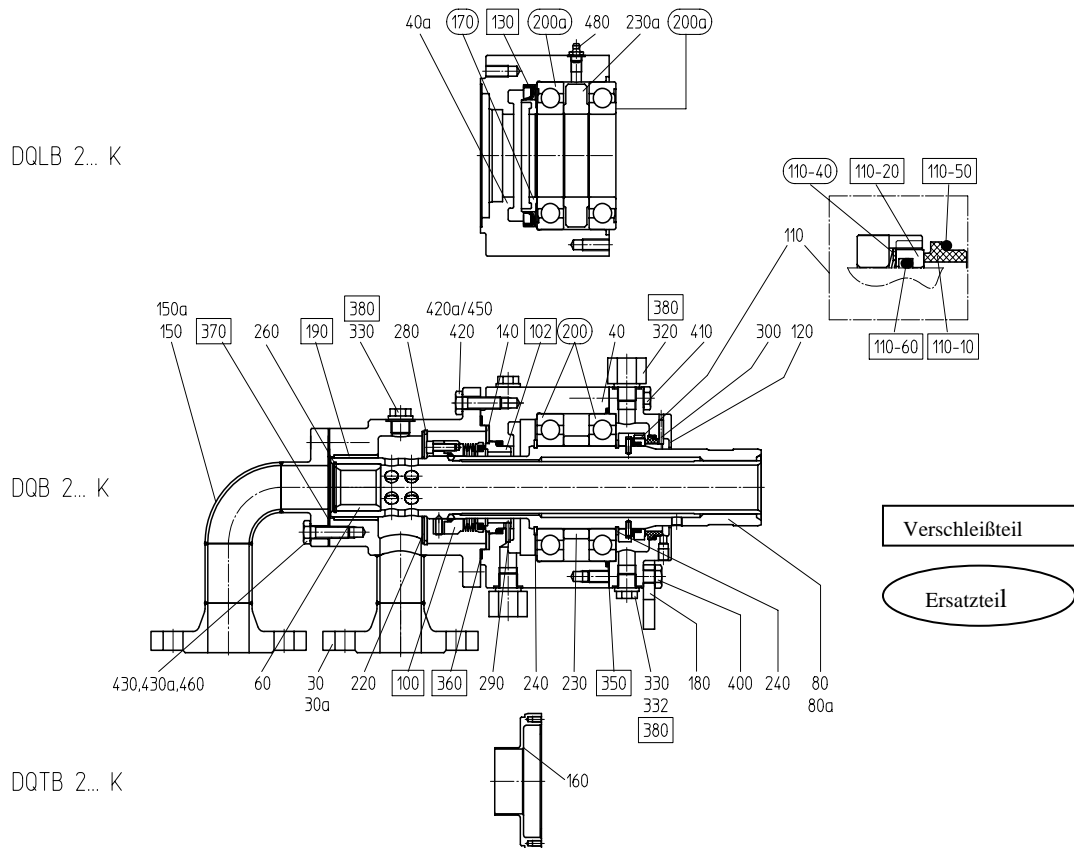

	DN [mm]	25	32	40		DN [mm]	25	32	40
	DN [inch]	1	1¼	1½		DN [inch]	1	1¼	1½
30	Housing DQB2 / DQLB2	1110102	1110177-120	1110252-090	220	Pressure plate	1110174	1110174	1110282-058
30a	Housing DQTB2	1110102-068	1110177-155	1110252-114	230	Spacer ring DQ / DQT	1110208	1110208	1110283
40	Bearing housing DQ / DQT	1110184-145	1110184-145	1110259	230a	Spacer ring DQL	1110208-151	1110208-151	1110283-082
40a	Bearing housing DQL	1110184-150	1110184-150	1110259-122	240	Circlip 1	3501023	3501023	3501024
60	Rotor bush	1110119	1110194	1110269	260	Circlip 2	3501239	3500697	3501225
80	Rotor K DQB2 / DQLB2	1110115	1110190-146	1110265	280	Retainer ring	3500696	3500696	3500706
80a	Rotor K DQTB2	1110115-072	1110190-157	1110265-116	290	Grooved pin 1	3500886	3500886	3500909-004
100	Spring unit prim. rot. mechanical seal	3511188-011	3511188-011	3511190-011	300	Grooved pin 2	3500890	3500890	3500890
102	Counter ring prim. Rot. mechanical seal	1110202-133	1110202-133	1110277-101	320	Reducer DQ / DQT	3513354	3513354	3513354
110	Second. rot. mechanical seal complete	1110201-141	1110201-141	1110276	330	Screw plug 1	3500658	3500658	3500658
110-10	Counter ring	3511404-077	3511404-077	3511405-046	332	Sensor plug	3500658-063	3500658-063	3500658-063
110-20	Slip ring	1110201-139	1110201-139	1110278	350	O ring	3511871-001	3511871-001	3511719-001
110-40	Compression spring	3511681	3511681	3511682	360	Flat packing 1	1110143-050	1110143-050	3512013
110-50	O ring 1	3511701-001	3511701-001	3511894-001	370	Flat packing 2	3512012	3512012	3212014
110-60	O ring 2	3511696-001	3511696-001	3511708-001	380	Sealing ring 1	3502116-001	3502116-001	3502116-001
120	Cover	1110210-092	1110210-092	1110285-086	400	Hex screw 1	3500053-007	3500053-007	3500128-007
130	Shaft sealing ring DQL	3511781-001	3511781-001	3511782-001	410	Hex screw 2	3500052-007	3500052-007	3500127-007
140	Holding disk	1110206	1110206	1110281-057	420	Hex screw 3 DQ / DQL	3500085-007	3500085-007	3500123-007
150	Elbow DQ / DQL	1110139	1110214-123	1110289-092	420a	Stud bolt 1 DQT	3500275	3500275	3500232
150a	Elbow DQT	1110139-064	1110214-152	1110289-119	430	Hex screw 4 DQ / DQL	3500084-007	3500084-007	3500123-007
160	Deflection bushing DQT	1110209	1110209	1110295-123	430a	Stud bolt 2 DQT	3500275	3500275	3500232
170	Shaft bushing DQL	1110223-154	1110223-154	1110298	450	Hex nut 1 DQT	3500301	3500301	3500303
180	Anti-rotation fork	1110212-066	1110212-066	1110287	460	Hex nut 2 DQT	3500301	3500301	3500303
190	Bushing	3510482	3210482	3510532	480	Conical lubr. nipple DQL	3500914	3500914	3500914
200	Deep groove ball bearing DQ/DQT	3510135-251	3510135-251	3510206-251					
200a	Deep groove ball bearing DQL	3510135-250	3510135-250	3510206-250					

Please specify exact rotary joint designation when inquiring or placing orders!.

Specifications and Spare Parts

Series DQ

S-DQ_en - Version 01.10.2008

Spare parts DQ 50-150 (1" - 6"

DQLB 2... K

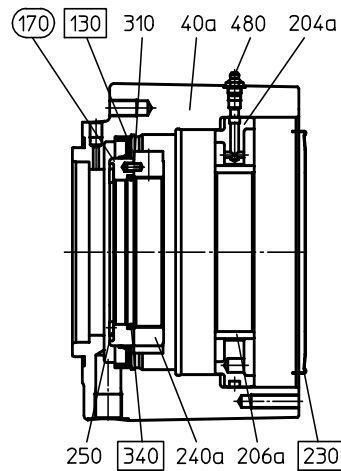

Wearing part

Spare part

DQB 2... K

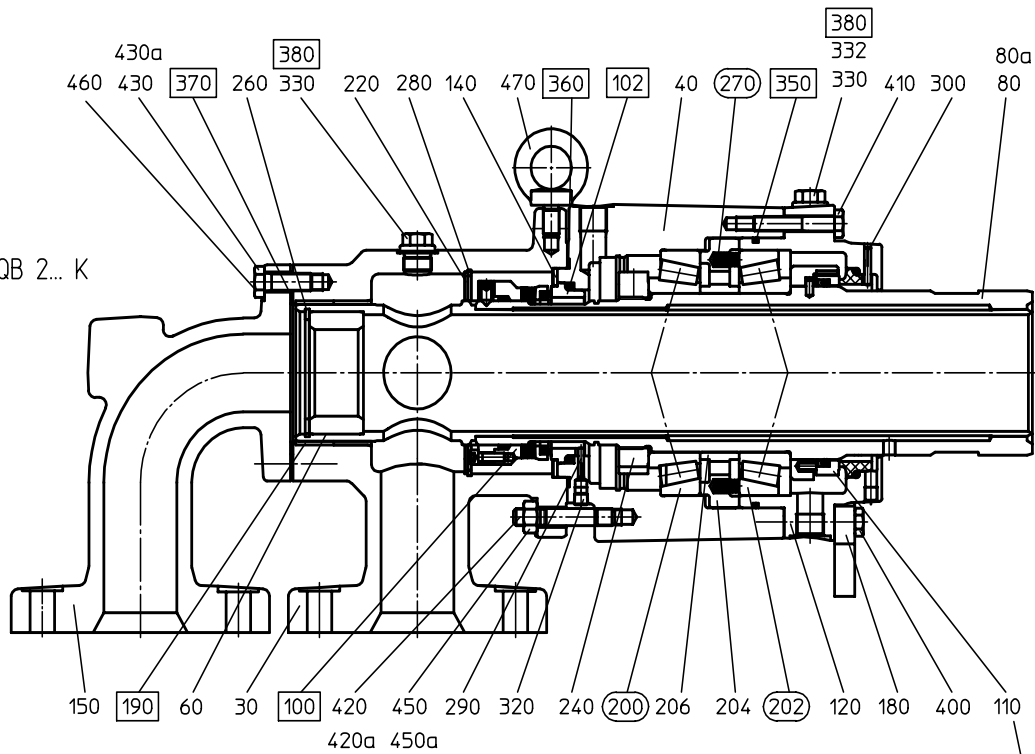

DQTB 2... K

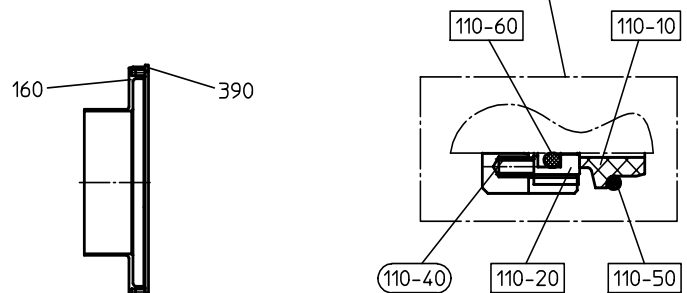



Specifications and Spare Parts

Series DQ

S-DQ_en - Version 01.10.2008

DN [mm] DN [inch]	50 2	65 2½	80 3½	100 4	125 5	150 6
30 Housing B2	1110327-135	1110402-142	1110477-209	1110552-148	1110627	1110702
40 Bearing housing DQ / DQT	1110334-137	1110409-141	1110484-210	1110559-135	1110634	1110709
40a Bearing housing DQL	1110334-151	1110409-145	1110484-224	1110559-159	1110634-160	1110709-146
60 Rotor bushing	1110344-080	1110419	1110494-140	1110569-109	1110644	1110719
80 Rotor K DQB2 / DQLB2	1110340-138	1110415-108	1110490-214	1110565-136	1110640-132	1110715
80a Rotor K DQTB2	1110340-141	1110145-159	1110490-232	1110565-166	1110640-165	1110715-171
100 Spring unit prim. rot. mechanical seal	3511191-011	3511192-011	3511193-011	3511194-011	3511195-011	3511196-011
102 Counter ring prim. rot. mechanical seal	1110352-119	1110399-102	1110502-198	1110549-130	1110652-113	1110727-126
110 Second. rot. mechanical seal compl.	1110351	1110426	1110501	1110576	1110651	1110726
110-10 Counter ring	3511406-043	3511407-049	3511408-077	3511409-043	3511410-043	3511411-041
110-20 Slip ring	1110353	1110399-092	1110503-111	1110578	1110653	1110728-153
110-40 Compression spring	3511683	3511685	8 x 3511553	8 x 3511550	8 x 3511551	8 x 3511551
110-50 O ring 1	3511871-001	3511716-001	3511873-001	3511703-001	3511725-001	3511727-004
110-60 O ring 2	3511869-001	3511715-001	3511874-001	3511702-001	3511712-001	3511726-004
120 Cover	1110360	1110435-144	1110510-212	1110585-145	1110660-125	1110735
130 Shaft sealing ring DQL	3511180-001	3511953	3511972	3511178-001	3511181-001	3511165
140 Holding disk	1110356-144	1110431-120	1110506-219	1110581-150	1110656-059	1110731-054
150 Elbow	1110364	1110439-143	1110514-138	1110589-097	1110664	1110739
160 Deflection bushing DQT	1110348-146	1110423	1110522-231	1110597-149	1110648	1110723
170 Shaft bushing DQL	1110373-145	1110448-134	1110523-222	1110598-139	1110673-139	1110729
180 Anti-rotation fork	1110362-083	1110437-115	1110512-220	1110587-146	1110662-140	1110737
190 Bushing	3510523	3510539	3510513	3510519	3510485	3510491
200 Tapered roller bearing 1	3510142	3510044	3510027-250	3510025-250	3510072-250	3510024-250
202 Tapered roller bearing2	3510045	3510044	3510027-250	3510021-250	3510072-250	3510023-250
204 Spacer ring DQ,DQT	1110358-147	1110433-113	1110508-217	1110583-144	1110658-136	1110733
204a Spacer ring DQL	1110358-148	1110433-132	1110508-225	1110583-162	1110658-162	1110733-140
206 Adapter ring	1110359-136	1110436	1110509-218	1110586-143	1110661	1110736
206a Adapter ring DQL	1110359-152	1110436-135	1110509-226	1110586-169	1110661-168	1110736
220 Pressure plate	1110357-149	1110432-065	1110507-180	1110582-151	1110657-061	1110732-056
230 NILOS ring DQL	3509060	3509076	3509075	3509062	3509058	1110738
240 Grooved nut DQ / DQT	3513513	3513512	3513508	3513505	1110624-137	1110699-138
240a Grooved nut DQL	1110324-150	1110399-133	1110474-223	1110549-160	1110624-137	1110699-138
250 Circlip 1 DQL	3500930	3500950	3501037	3500949	3500959	3500954
260 Circlip 2	3501232	3501236	3501205	3501251	3501207	3501237
270 Compr. spring for bearing seat	3511525	3511558	3511560	3511558	3511587	3511557
280 Retainer ring	3500870	3500874	3500693	3501050	3500709	3500871
290 Grooved pin 1	3500909-004	3500909-004	3500890	3500922	3500922	3500896
300 Grooved pin 2	3500909-004	3500909-004	3500922	3500922	3500922	3500922
310 Grooved pin 3	3500940	3500940	3500940	3500940	3500940	3500940
320 Screw plug G 1/8	3500664	3500664	3500664	3500664	3500664	3500664
330 Screw plug G 1/2	3500655	3500655	3500655	3500655	3500655	3500655
332 Sensor plug	3500655-158	3500655-158	3500655-158	3500655-158	3500655-158	3500655-158
340 O ring DQL	3511701-001	3511869-001	3511871-001	3511776-004	3511780-004	3511758-001
350 O ring DQ / DQT	3511755-001	3511839-001	3511758-001	3511773-001	3511757-001	3511759-001
360 Flat packing 1	1110444-062	3512018	1110594-070	1110669-063	1110668-084	1110743-116
370 Flat packing 2	3512281	1103449-261	1110519-154	3512018	3512020	3512255
380 Sealing ring	3502115-001	3502115-001	3502115-001	3502115-001	3502115-001	3502115-001
390 Circlip DQT	3500873	3500948	3500692	3500947	3500699	3500875
400 Hex screw 1	3500137-007	3500094-007	3500134-007	3500137-007	3500137-007	3500173-007
410 Hex screw 2	3500134-007	3500092-007	3500128-007	3500128-007	3500134-007	3500164-007
420 Stud bolt or hex screw	3500123-007	3500164-007	3500274-007	3500271-007	3500271-007	3500271-007
420a Stud bolt DQT	3500257	3500279	3500986	3500242-007	3500242-007	3500242-007
430 Hex screw 3	3500123-007	3500123-007	3500165-007	3500161-007	3500166-007	3500204-007
430a Stud bolt DQT	3500257	3500257	3500227-007	3500234	3500234	3500236
450 Hex screw	---	---	3500285-007	3500287-007	3500287-007	3500287-007
450a Hex nut DQT	3500303	3500285-001	3500285-001	3500300	3500300	3500300
460 Hex nut DQT	3500303	3500303	3500285-001	3500285-001	3500285-001	3500300
470 Ring bolt	3500668	3500686	3500668	3500668	3500668	3500668
480 Conical lubrication nipple	3500914	3500914	3500914	3500914	3500914	3500914



Specifications and Spare Parts

Series DQ

S-DQ_en - Version 01.10.2008

Please specify exact rotary joint designation when inquiring or placing orders!