

Fuels Burned and Control Systems

- Natural Gas, Propane, Digester or Mixed Gases
- Light #2 through Heavy #6 Fuel Oil
- Low Fire Start, Low-High-Low, Modulating or Micro Modulation
- Control Circuit Requires 120 vac, 60 Hz, Single Phase Voltage Supply

Check appropriate box to indicate selected version. (Dimensions are +/- 1/4inch)

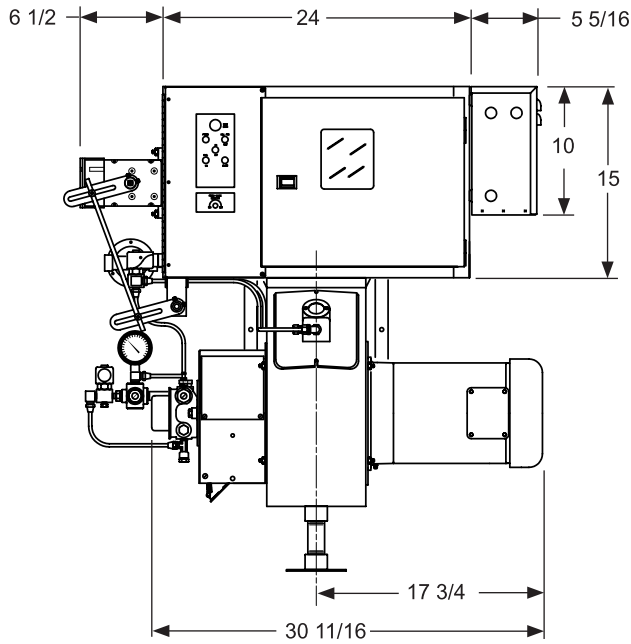

**Standard Arrangement
End View**

Check Box

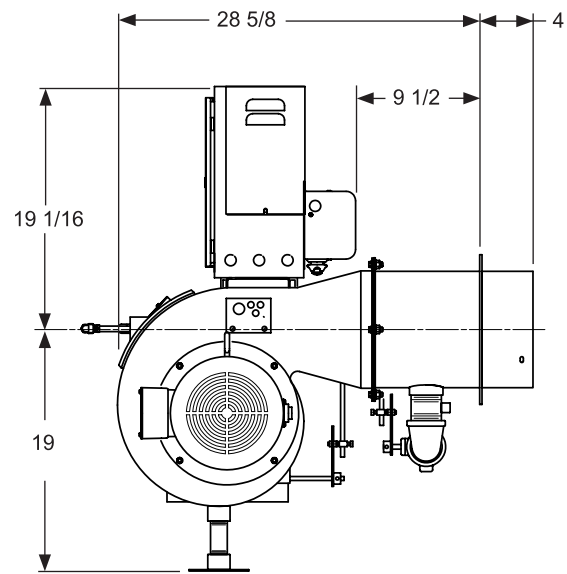

**Standard Arrangement
Elevation
Side View**

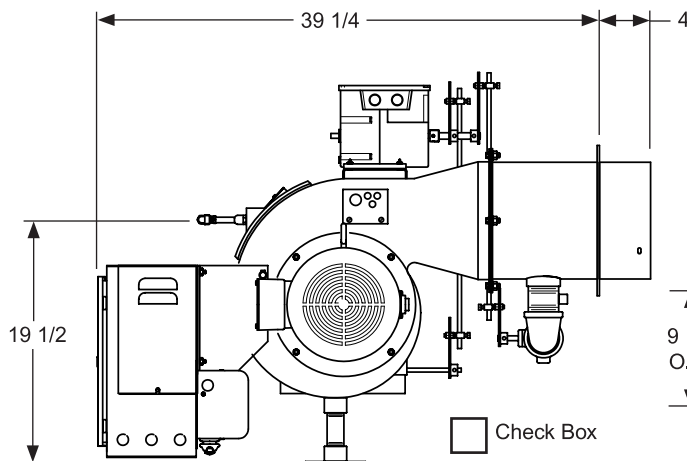

**Standard Burner Arrangement
Elevation
W/ Optional Back Mount Control Cabinet
Side View**

Check Box

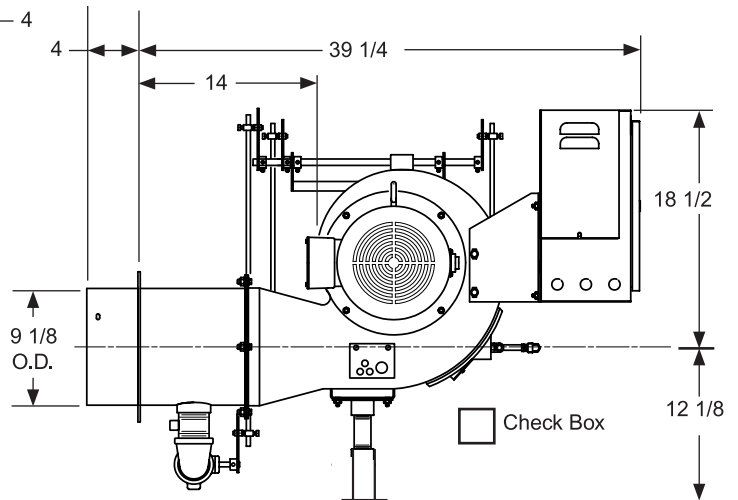

**Inverted Burner Arrangement
Elevation
Side View**

Check Box

Model JB2 burners are listed by Underwriters Laboratories, Inc. (UL / ULC). Also by the State of Massachusetts Fire Marshal, City of New York Board of Standards and Appeals, State of Minnesota and can be packaged to meet specific requirements of IRI, FM, GE GAP, NFPA, MIL spec. or other special insurance or local code requirements.

(1) STANDARD UL EQUIPMENT AND IMPORTANT OPTIONS		Gas	No. 2 Oil		STANDARD UL EQUIPMENT AND IMPORTANT OPTIONS		Gas	No. 2 Oil	
			Pressure Atomized	Air Atomized				Pressure Atomized	Air Atomized
General	Motor, Fan and Air Inlet Control	X	X	X	Gas Fuel	Main Manual Shutoff Valve	X		
	Air Flow Switch	X	X	X		Main Safety Shutoff Valve	X		
	(2) Burner Mounted Control Panel, Switch and Indicator Lights	X	X	X		Second Safety Shutoff Valve	X		
	Flame Safety Control	X	X	X		Main Gas Regulator	X		
	Ultra Violet Scanner	X	X	X		Gas Checking Valve	X		
	Motor Controller (single phase voltage)	X	X	X		High and Low Gas Pressure Switches	X		
	Motor Starter w/Overloads (3 PH volt)	X	X	X		Metering Valve (modulating systems)	X		
	Fuel Selector Switch	Duel Fuel Burners Only				Normally Open Vent Valve	Opt.		
Ignition	Proven Gas Pilot Ignition	X		X	Oil Fuel	Oil Drawer Assembly with Diffuser		X	X
	(1) JB2-30 and JB2-50	X	X	X		Oil Nozzles		X	X
	Pilot Solenoid Gas Valve	X		X		Integral Oil Pump (JB2-07 to JB2-20)		X	
	Pilot Gas Regulator & Manual Valve	X		X		Remote Oil Pump (JB2-30 to JB2-50)		X	Opt.
	Pilot Gas Ignition Transformer	X		X		Two Safety Shutoff Valves		X	X
	Direct Spark Oil Ignition			(3)		Low Air Atomizing Switch			X
	Direct Spark Oil Ignition Transformer			(3)		Low Oil Pressure Switch (STD when using remote oil pump)		X	X
Options	Inverted Housing	X	X	X		Oil Pressure Gauge		X	X
	Alternate Control Cabinet Positioning	X	X	X		Oil Metering Valve (modulating system)		X	X
	Remote Control Panel	X	X	X		Future Gas Combustion Head		Opt.	Opt.
	Fuel Metering CAM-NETIC II	X	X	X		Air Compressor			X

1. The configuration of each unit will vary with specific job requirements such as input rating, electrical specification and special agency approval codes. The above chart shows those items standard to a basic burner plus a few options that may be added.

2. Indicator lights are "Power On", "Call for Heat", "Fuel On" and "Flame Fail" for hard wired panels. "Alarm", "Low Water", "Power", "Call for Heat", "Ignition On", and "Fuel On" for circuit board light panels.

3. Maximum rate for direct spark is 20 GPH at low fire or 35 GPH at high fire. (standard on straight oil burners, pressure atomized)

Model JB2 - Sizing and Application Data (contact Webster for complete information)

Model Number	Maximum Furnace Pressure	Burner Firing Capability Range		Burner Motor HP	Gas Train			Oil Pump Motor HP		Air Compressor Motor HP
					Pipe Size	(3) Inlet Press (in wc)		Pressure Atomizing	Air Atomizing	
		Gas scfh	#2 Oil gph			LFS, LHL	Modulation			
JB2-07	2	900 / 2800	10 / 20	3/4	1 1/2"	10 / 14"	13"	Integral	N/A	N/A
JB2-10	2	900 / 3500	10 / 25	1	2"	8 / 14"	9 / 14"	Integral	Optional	2
JB2-15	2	900 / 3500	10 / 25	1 1/2	2"	8 / 14"	9 / 14"	Integral	Optional	2
JB2-20	2	1200 / 4200	12 / 30	2	2"	(4) 12 / 14"	(3) 13 / 14"	Integral	Optional	2
JB2-30	2.5	1200 / 5300	12 / 37.8	3	2 1/2"	N/A	13 / 14"	3/4	Optional	2
JB2-50	2.5	1200 / 6000	12 / 42.8	5	2 1/2"	N/A	2-5 psi	3/4	Optional	2

3. Lower pressures may apply to reduced inputs.

4. 11-14" with IRI and LFS or LHL. 12-14" with IRI and modulation.

The above maximum ratings are based on 0 furnace pressure, an altitude of 1000 feet, 90°F air temperature and 60 HZ electrical supply. Use the following corrections for higher temperatures and altitude. Capacity decreases by 17% for 50 Hertz.

Capacity decreases by 4% for each 1000 feet above 1000 foot altitude.

Capacity decreases by 6% for each 1 inch of furnace pressure.

Capacity decreases by 2% for each 10°F increase in air temperature over 90°F.

Gas input ratings based on 1000 BTU/cu ft. and 0.64 specific gravity. Sizes and pressure will vary with different gas properties.

Oil input ratings are based on 140,000 BTU/gal. for ASTM #2 fuel oil.

The vessel draft must be between -0.1 and +0.1 wc.

Essential Ordering Information and Data:

Power Supply - Confirm 120-60-1 for control circuit and electrical supply for burner motor(s) (voltage, frequency and phase).

Describe Boiler or Heater to be Fired - Including the manufacturer, model number, furnace pressure and furnace size.

Firing Rate - Define firing rates in MBH for gas and GPH for oil.

Fuel to be Burned - Type of gas and/or oil, including the BTU value.

Approval Agency - UL, FM, IRI (GE GAP), CSD-1, NFPA, Mil spec and local codes, if applicable.

Flame Safety Control Preferred - Honeywell or Fireye controls. Gas Train Components Preferred - ASCO/ITT, Honeywell or Landis

Control System - ON-OFF, Low Fire Start, Low High Low, Modulation, Posi-Control. Required Options - Mounting plate, limit controls, etc.