

M70

Issue Date: February 2018

Introduction

Reasonable Care has been taken whilst preparing this technical manual. The information provided in this manual should be treated as guidance only. VEKA PLC cannot control how the information is interpreted and therefore, cannot be held responsible for any failure and is supplied on the understanding that the user accepts all risks associated with the use of the information contained within it. Regulations regarding health and safety of operatives along with relevant building regulations should be strictly adhered to, as such VEKA PLC cannot be held responsible for any failure to comply with them. This statement does not affect the fabricators statutory rights.

The copyright of this manual remains the property of VEKA PLC this document may not be copied or used for any other purpose other than its intended use without the prior written consent of VEKA PLC.

Do not scale drawings in this manual. The drawings shown are visual representations only. VEKA PLC has the right to alter the designs, specification & descriptions without prior notice as part of our policy of continuous development and improvement.

The M70 system is designed to internally beaded only. Any glazing used should be in accordance with the most recent British standard applicable to the installation.

Air equalisation is not mandatory in all situations and may only be necessary for windows or doors in exposed locations or where installed above three floors or 10 meters above ground level. It is not therefore required for general domestic installations unless weather conditions are known to be particularly severe. Chamber venting for dark foiled material may also be required on large profile sections in some locations. For advice on this please refer to the appropriate VEKA guide lines manual or contact the Technical Department for advice.

1.01.1	Outerframes, Transoms/Mullions & Thresholds
1.02.1	Sashes/Transoms/Mullions, Mullion Adapters
1.02.2	Glazing Options
1.03.1	Moulded Parts, Repair Gasket & Drips
1.04.1	Frame Extenders & Cills
1.05.1	Inline Couplers
1.06.1	Bay Couplers
1.07.1	Bay Couplers Continued
1.08.1	Plant On Reinforcing
2.01.1	Reinforcement Specification and Minimum & Maximum Sizes
2.02.1	Combined Safety Iyy Values
2.03.1	Profile Combinations - Casement
2.04.1	Profile Combinations - Tilt & Turn
2.05.1	Profile Combinations - Open In Door
2.06.1	Profile Combinations - Open Out Door
2.07.1	Profile Combinations - Low Thresholds
2.08.1	Profile Combinations - Alternative Door Frame Transoms
2.09.1	Profile Combinations - French Door Mullion
2.10.1	Profile Combinations - French Casement Mullion
2.11.1	Fire Egress - Tilt & Turn
2.12.1	Fire Egress - Casement
2.13.1	Reductions - Casement
2.14.1	Reductions - Casement
2.15.1	Reductions - Casement
2.16.1	Reductions - Casement
2.17.1	Reductions - Tilt & Turn
2.18.1	Reductions - Tilt & Turn
2.19.1	Reductions - Residential Door
2.20.1	Reductions - Residential Door
2.21.1	Reductions - French Door
2.22.1	Reductions - French Door
2.23.1	Weld Test Data
3.01.1	Drainage
3.02.1	Drainage Continued
3.03.1	Drainage Routes
3.04.1	Drainage Routes Continued
3.05.1	Drainage Routes Continued
3.06.1	Profile Milling Dimensions
3.07.1	Reinforcing
3.08.1	Reinforcing Continued
3.09.1	Mechanical Joint Reinforcing
3.10.1	Low Threshold Preparation
3.11.1	Low Threshold Fixing
3.12.1	Hardware Specification
3.13.1	Screw Specification
3.14.1	Screw Specification Continued
4.01.1	Thermal Performance - Windows
4.02.1	Thermal Performance - Doors
4.03.1	Kitemark Schedule - Windows
4.04.1	Kitemark Schedule - Doors
4.05.1	Kitemark Approved Hardware - Top Hung Casement
4.06.1	Kitemark Approved Hardware - Side Hung Casement
4.07.1	Kitemark Approved Hardware - Tilt And Turn
4.08.1	Kitemark Approved Hardware - Single Door & French Door
4.09.1	Kitemark Additional Hardware Positions
4.10.1	Kitemark - Profiles
4.11.1	Kitemark - Profiles Continued
5.01.1	Amendments 1
5.02.1	Amendments 2
5.03.1	Amendments 3
5.04.1	Amendments 4

COMPONENTS

1.00.1	This Page
1.01.1	Outerframes, Transoms/Mullions & Thresholds
1.02.1	Sashes/Transoms/Mullions, Mullion Adapters
1.02.2	Glazing Options
1.03.1	Moulded Parts, Repair Gasket & Drips
1.04.1	Frame Extenders & Cills
1.05.1	Inline Couplers
1.06.1	Bay Couplers
1.07.1	Bay Couplers Continued
1.08.1	Plant On Reinforcing

COMPONENTS

1

DESIGNS AND STATISTICS

2

MANUFACTURE

3

ACCREDITATIONS

4

REVISIONS

5

Outerframes, Transoms/Mullions & Thresholds.

1

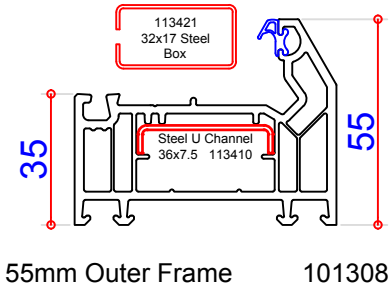

55mm Outer Frame 101308

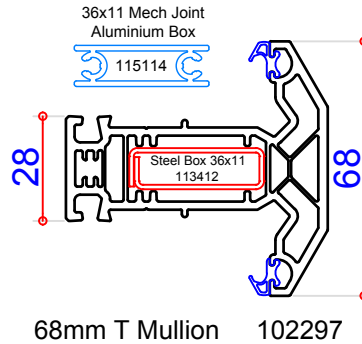

68mm T Mullion 102297

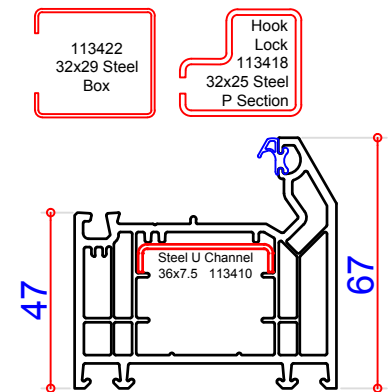

67mm Outer Frame 101309

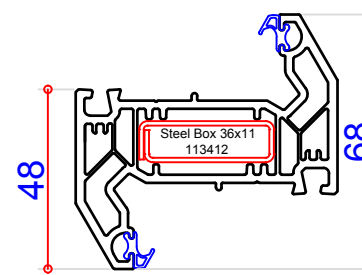

68mm Z Mullion 102298

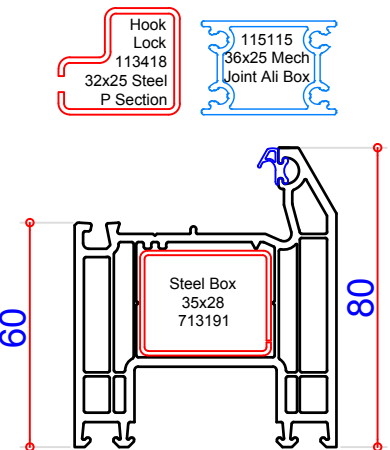

80mm Outer Frame 105176

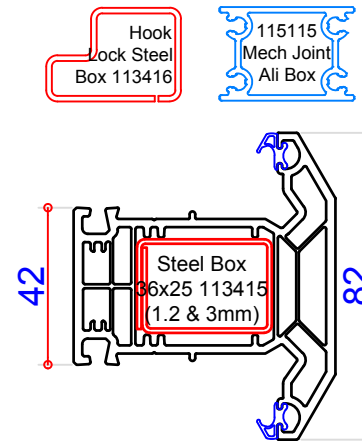

82mm T Mullion 102299

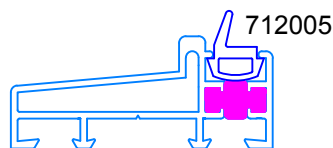

Standard Low Threshold 704092

709225 Part M Low Threshold adapter

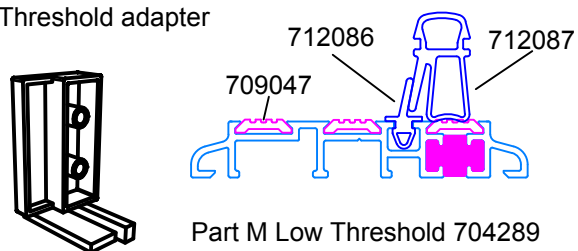

Part M Low Threshold 704289

Sashes/Transoms/Mullions.

1



Steel P Section 113423
 Available in prepped lengths
 475mm 113423.000001
 775mm 113423.000002
 1075mm 113423.000003
 1150mm 113423.000005
 1200mm 113423.000006

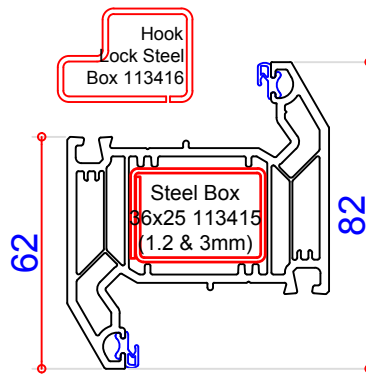

Hook Lock Steel Box 113416
 Steel Box 36x25 113415 (1.2 & 3mm)
 62
 82

82mm Z Mullion 102296

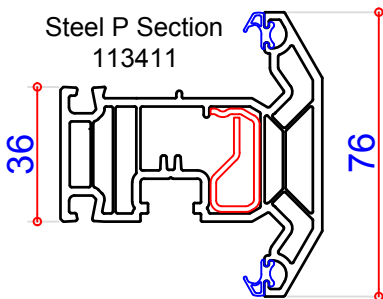

Steel P Section 113411
 36
 76

76mm Casement Sash/T Mullion 103365

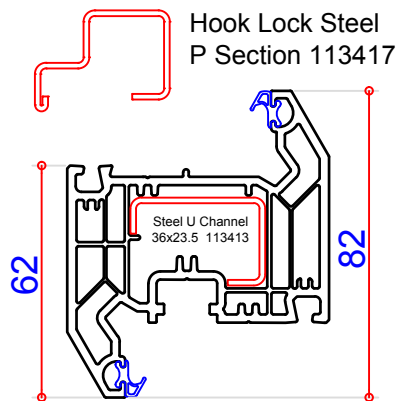

Hook Lock Steel P Section 113417
 Steel U Channel 36x23.5 113413
 62
 82

82mm Tilt & Turn Sash/Z Mullion 103364

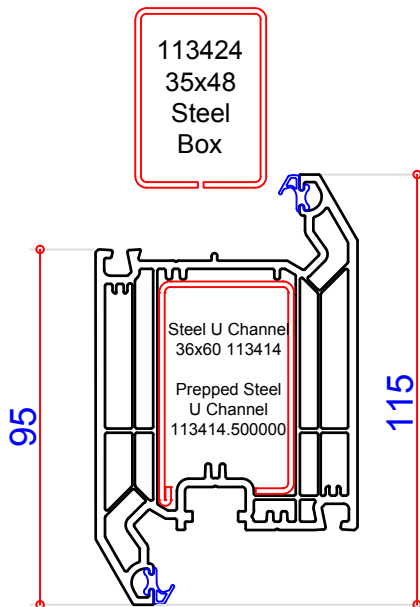

113424 35x48 Steel Box
 Steel U Channel 36x60 113414
 Prepped Steel U Channel 113414.500000
 95
 115

115mm Open In Door Sash/Z Midrail 103366

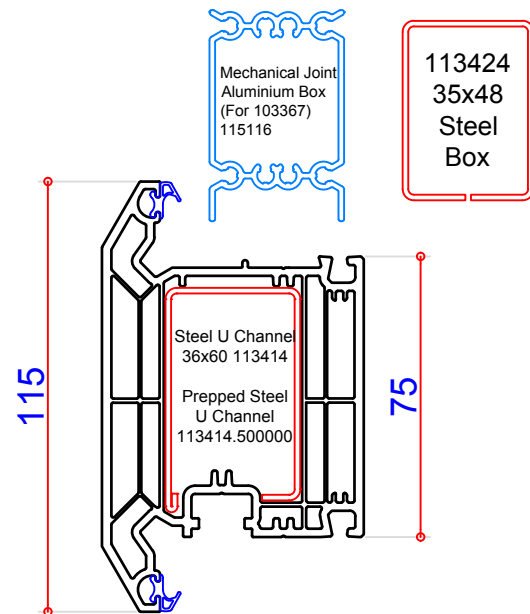

Mechanical Joint Aluminium Box (For 103367) 115116
 113424 35x48 Steel Box
 Steel U Channel 36x60 113414
 Prepped Steel U Channel 113414.500000
 115
 75

115mm Open Out Door Sash/T Midrail 103367

Glazing Bead Options.

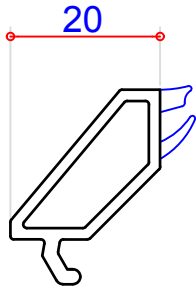

28mm Chamfered
Glazing Bead 107154

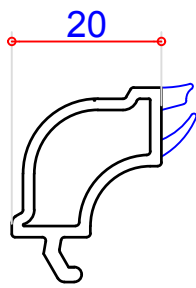

28mm Feature
Glazing Bead 107153

Due to the gasket form on 107218 & 107228 when used with dark foiled profiles it is recommended that the DGU size is reduced by 4mm to prevent the section of PVC between the two gaskets being visible externally.

36mm Glazing
Bead 107218

1

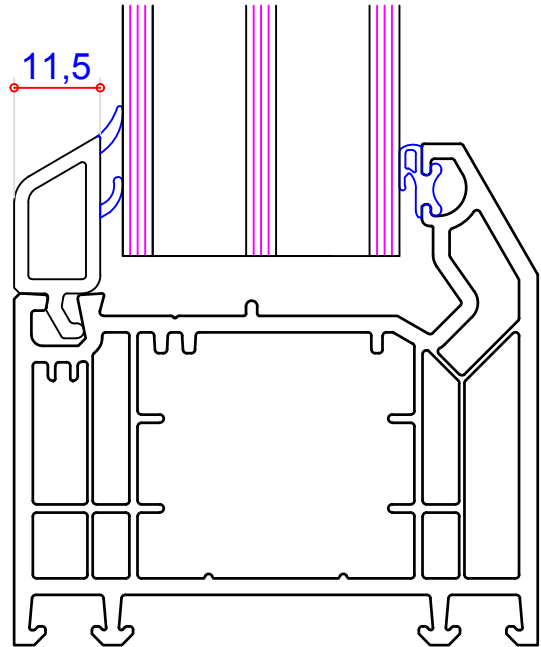

40mm Glazing
Bead 107228

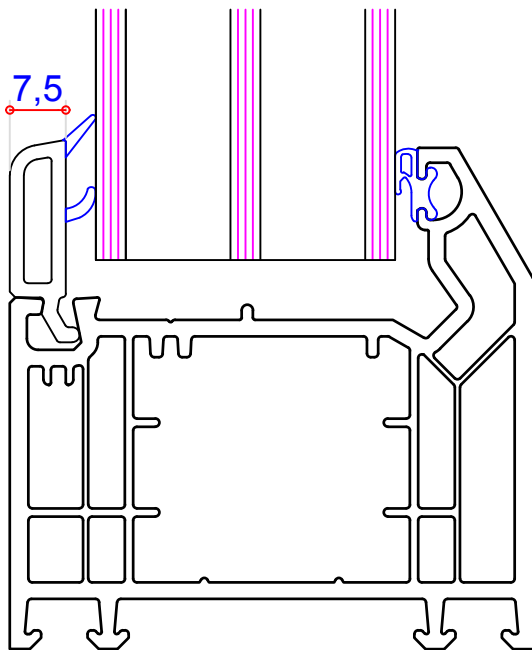

44mm Glazing Bead 107156 (no gasket)
Gasket 112135

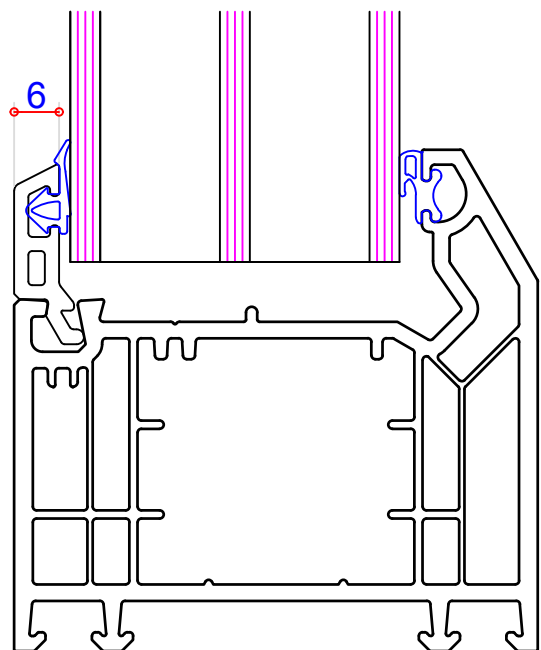

Moulded Parts, Repair Gasket & Drips.

1



French Door Mullion Adapter
(For 102297) 104396



French Window Mullion Adapter
(For 102297) 104397

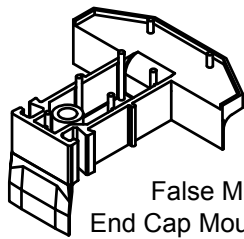

False Mullion
End Cap Moulding
(for 102297) 109057

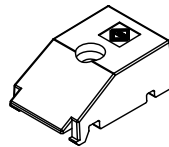

Casement Rider Block
(17-18mm Stack) 109056

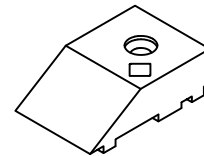

Door & Tilt & Turn
Rider Block 109398

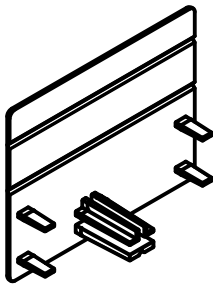

109167
Profile Cover Cap

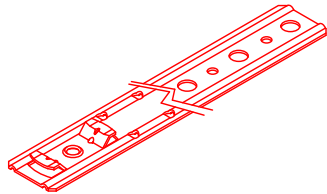

Frame Fixing Bracket 141428
available sizes 175, 200 & 250mm

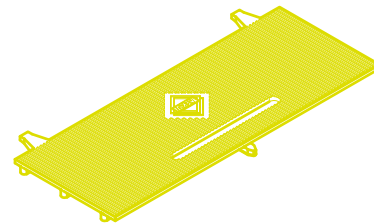

Clip In Packer 109060



Eurogroove Infill
109045



Universal Frame
Infill 105173



Snap-on Head
Drip 109230



3.5mm Repair Gasket
112279



Door Drip End Cap 709192
709223



Drip Bar End Cap 709149
709220



Drip Bar End Cap 709317
709232



Nipple Screw
744163

Frame Extenders & Cills.

1

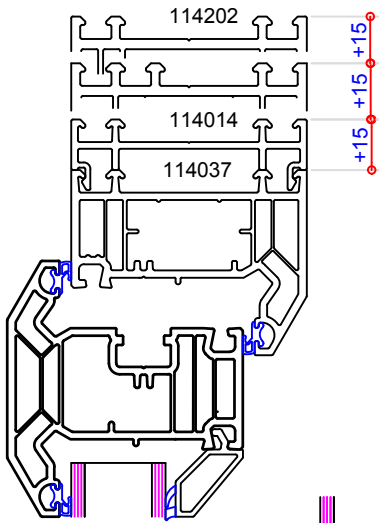

Frame Extensions are available for increasing clearance when required at installation.

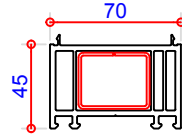

45mm Frame Extension 114202
Steel Box 38 x 30mm 113271

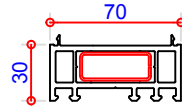

30mm Frame Extension 114014
Steel Box 38 x 15mm 113073

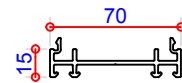

15mm Frame Extension 114037

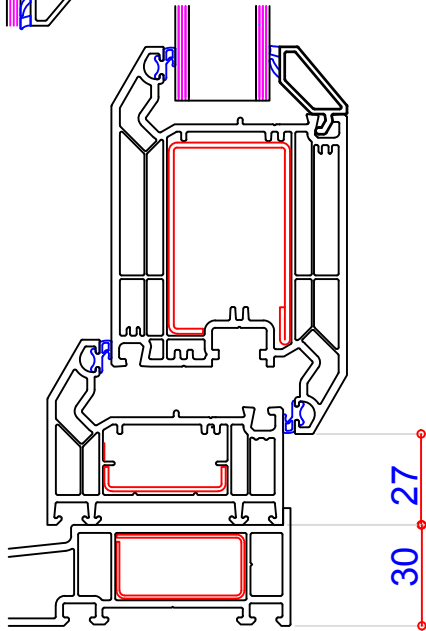

55mm Outer Frame 101308

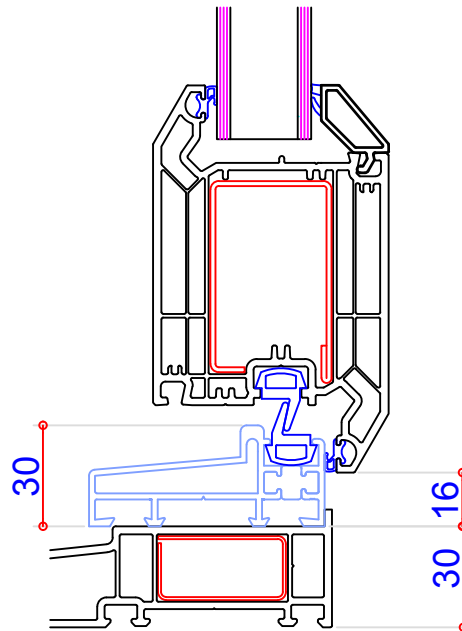

Standard Low Threshold 704092

Optional Cills are available where required

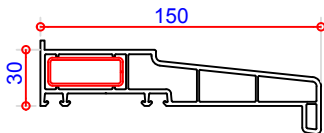

150mm Cill 110103
Steel Box 713016
End Caps 109006
Straight Coupler 109010

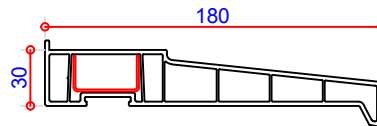

180mm Cill 110076
Steel U Channel 113377
End Cap 109090

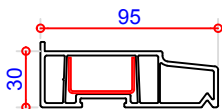

95mm Cill 110074
Steel U Channel 113377
End Cap 109074

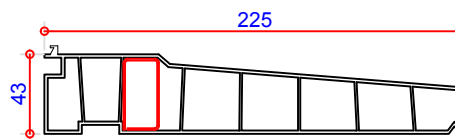

225mm Cill 110106
Steel Box 113048
Steel L Box 113345
End Cap 109647

Inline Couplers (Non Load Bearing).

1

$i_{yy} = 11.77\text{cm}^4$ (equivalent aluminium i_{yy} value = 37.75cm^4)

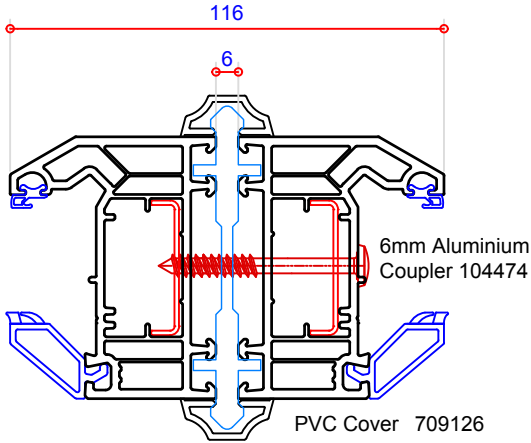

$i_{yy} = 19.06\text{cm}^4$ (equivalent aluminium i_{yy} value = 61.1cm^4)

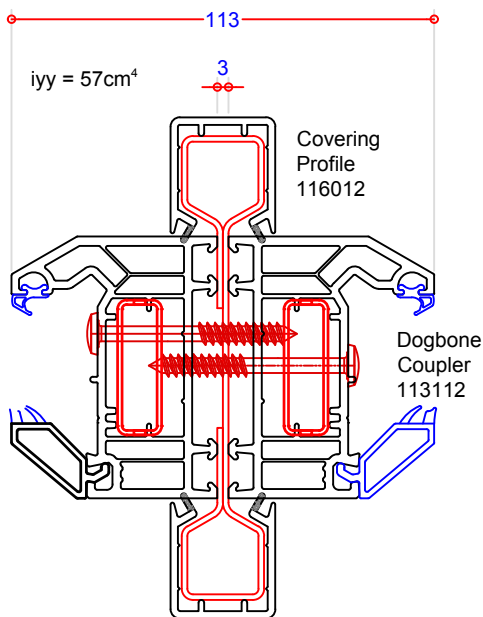
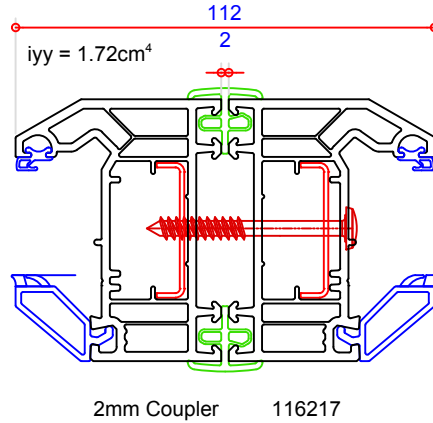
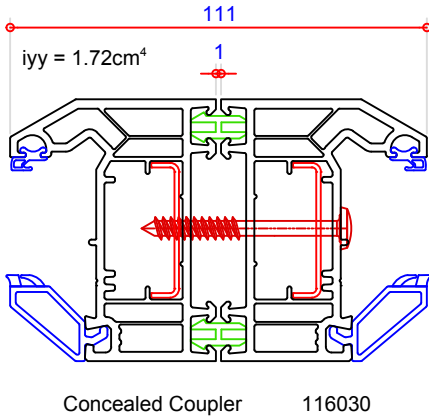
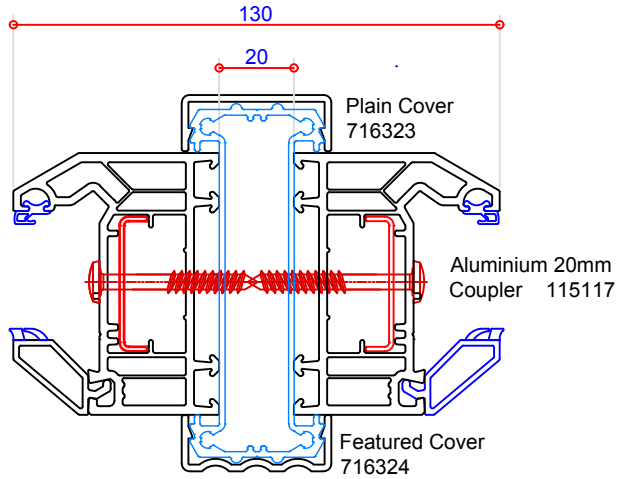

5.5 x 50mm Pan Head or bay pole Self Tapping Screw (Non VEKA part) Maximum 300mm Centres.



The suitability and required "i" value of couplings depends on frame type, design, size and location. For advice please refer to the VEKA "Reinforcement Guide Lines" manual or contact the VEKA Technical Team.

Bay Couplers.



709162 Featured Cover

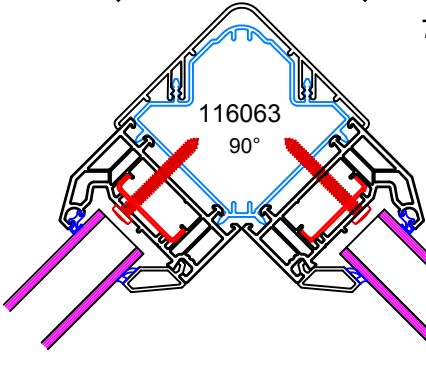

709321 Plain Cover

Zero frame deduction required

163

5.5 x 50mm Pan Head or bay pole Self Tapping Screw (Non VEKA part) Maximum 300mm Centres.



709168 Featured Cover

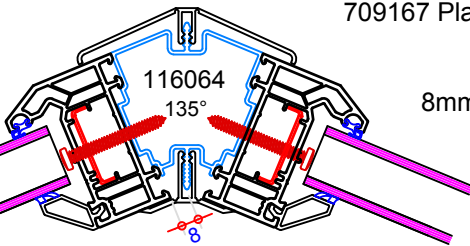

709167 Plain Cover

8mm per frame deduction required

709164 Small Cover

162



709166 Featured Cover

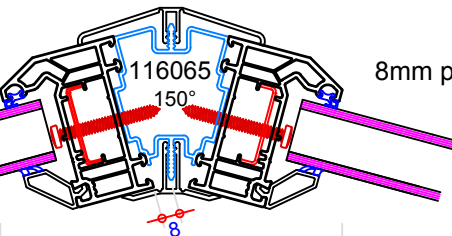

709165 Plain Cover

8mm per frame deduction required

709164 Small Cover

153

For load bearing applications load bearing plates are required. Please refer to the VEKA Coupling manual or contact the VEKA Technical Team for advice.

Bay Couplers Continued.

709164 120 - 145°
Internal Post Cover

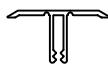

709163 146 - 170°
Internal Post Cover



704801 Variable
Bay Post

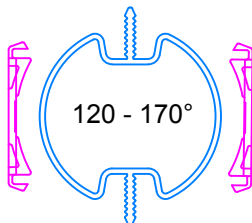

109059 Adapter
(For 704801)

709165 146 - 170°
Plain Post Cover



709166 146 - 170°
Featured Post Cover



709167 120 - 145°
Plain Post Cover

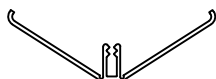

709168 120 - 145°
Featured Post Cover

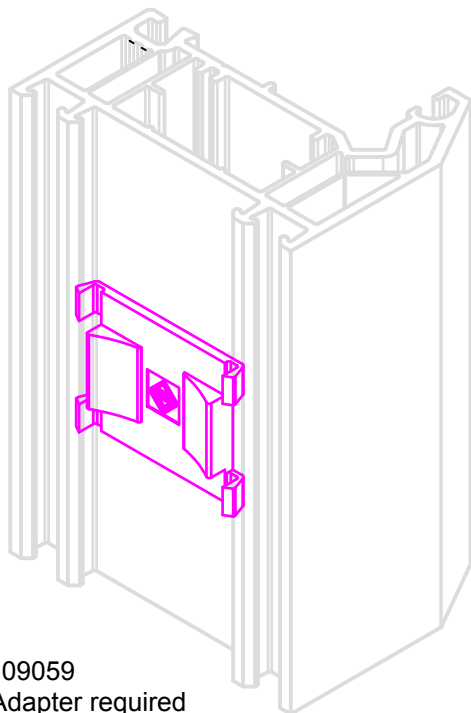

109059
Adapter required
top - bottom and adjacent to
required fixings.

Reductions Per Frame

Angle (°)	Per Frame (mm)		Angle (°)	Per Frame (mm)
170°	-22mm		140°	-13mm
169°	-22mm		139°	-12mm
168°	-22mm		138°	-12mm
167°	-21mm		137°	-12mm
166°	-21mm		136°	-11mm
165°	-21mm		135°	-11mm
164°	-20mm		134°	-10mm
163°	-20mm		133°	-10mm
162°	-20mm		132°	-10mm
161°	-19mm		131°	-9mm
160°	-19mm		130°	-9mm
159°	-19mm		129°	-9mm
158°	-19mm		128°	-8mm
157°	-18mm		127°	-8mm
156°	-18mm		126°	-8mm
155°	-18mm		125°	-7mm
154°	-17mm		124°	-7mm
153°	-17mm		123°	-6mm
152°	-17mm		122°	-6mm
151°	-16mm		121°	-6mm
150°	-16mm		120°	-5mm
149°	-16mm			
148°	-15mm			
147°	-15mm			
146°	-15mm			
145°	-14mm			
144°	-14mm			
143°	-14mm			
142°	-13mm			
141°	-13mm			

1

PLANT-ON REINFORCEMENT

1

In order to increase the strength of both the mullion / transom, the use of a 'plant-on reinforcement' is recommended. The 'plant-on' may be secured to either the external or internal face of the profile as detailed below.

External - Sealant must be used down the sides of the PVC-u trim & the ends must be capped / treated.
Internal - No further sealing is necessary.

Plant-on reinforcement must be secured to the mullion / transom with fixing screws positioned as follows; at each end of the mullion / transom (secured into outer frame), within 100mm to 150mm of the weld & at no more than 300mm intervals along the full length of the mullion / transom.

Attention should be taken by the installer to select adequate fixings at both ends of the mullion / transom. The frame must also be continuously reinforced to help distribute end loads

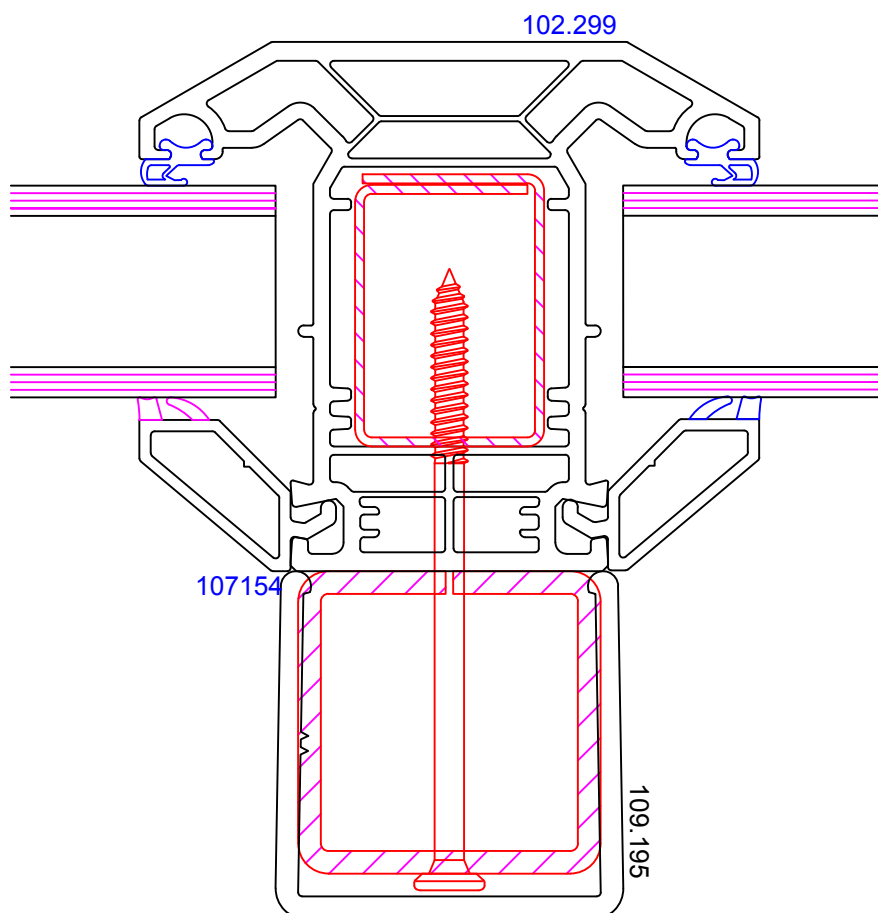

DESIGNS & STATISTICS

2.00.1	This page
2.01.1	Reinforcement Specification and Minimum & Maximum Sizes
2.02.1	Combined Safety iyy Values
2.03.1	Profile Combinations - Casement
2.04.1	Profile Combinations - Tilt & Turn
2.05.1	Profile Combinations - Open In Door
2.06.1	Profile Combinations - Open Out Door
2.07.1	Profile Combinations - Low Thresholds
2.08.1	Profile Combinations - Alternative Door Frame Transoms
2.09.1	Profile Combinations - French Door Mullion
2.10.1	Profile Combinations - French Casement Mullion
2.11.1	Fire Egress - Tilt & Turn
2.12.1	Fire Egress - Casement
2.13.1	Reductions - Casement
2.14.1	Reductions - Casement
2.15.1	Reductions - Casement
2.16.1	Reductions - Casement
2.17.1	Reductions - Tilt & Turn
2.18.1	Reductions - Tilt & Turn
2.19.1	Reductions - Residential Door
2.20.1	Reductions - Residential Door
2.21.1	Reductions - French Door
2.22.1	Reductions - French Door
2.23.1	Weld Test Data

COMPONENTS

1

DESIGNS AND STATISTICS

2

MANUFACTURE

3

ACCREDITATIONS

4

REVISIONS

5

Domestic Reinforcement Specification (maximum exposure 1200Pa)

The domestic reinforcement specification is applicable to the New Matrix 70 profile system using white and light coloured profiles only. This specification should only be used for houses up to 3 storeys in height and in geographical locations where wind loads do not exceed 1200 pascals.

Please note that some window installations falling into this category must be either locally or fully reinforced due to client specifications which must be confirmed prior to manufacture.

When producing windows & doorsets covered with dark coloured foils, please contact the VEKA Technical Team for further guidance regarding issues related to thermal expansion.

Consideration needs to be made to other factors involved which include requirements for PAS24 / SBD.

Outer Frame 101308 / 101309 / 105176

No reinforcement is required as long as direct fixing is possible in accordance with the recommendations of the relevant British Standard BS8213-4:2007 (Code of practice for the survey and installation of windows and external doorsets).

All frame members that are to be coupled together shall be reinforced, depending upon the coupling section which is used, it's application and the required rigidity of the section the reinforcement may have to be continuous.

Mullion / Transom 102297 / 102298 / 102299 / 102296

<u>Mullion length</u>	<u>Mullion selection*</u>
0mm - 1200mm	Un-reinforced
1201mm - 1400mm	68mm mullion with 113412 reinf.
1401mm - 1585mm	82mm mullion with 113415 std. reinf.
1586mm - 1725mm	82mm mullion with 113415 hd. reinf.
1726mm - 2200mm	82mm mullion with 113415 & 113128 'plant-on' reinf.

*based upon 1000mm mullion split

Sashes 103365 / 103364 / 103366 / 103367

The maximum sash sizes are determined by the choice of hinge, glazing unit, hardware, the profile and reinforcement specification. Ensure that the hinge manufactures recommendations for the overall sash weight and size restrictions are not exceeded. Due to these factors, it may not always be possible to manufacture sashes to the limits shown, if in any doubt contact your hinge supplier for advice. Wrap around gearing may be required to ensure the sash is sealed sufficiently.

Sash Type	Max. Width	Max. Height	Reinforcement Regime
 Side Hung Casement	700mm	1300mm	Un-reinforced
	800mm	1500mm	Fully reinforced
 Top Hung Casement	1100mm*	1100mm	Un-reinforced
	1400mm	1400mm	Fully reinforced
 Tilt & Turn	1200mm*	1200mm	Un-reinforced
	1600mm	1600mm	Fully reinforced
 Residential Door	850mm	2122mm	Locally reinforced ^
	1122mm	2122mm	Fully reinforced
 French Door	850mm	2122mm	Locally reinforced ^
	1122mm	2122mm	Fully reinforced

* When using the espagnolette sashes the bottom rail of the sash should be reinforced over 900mm in a continuous length.

^ Due to the overall size of the sashes that may be manufactured, the weight and loadings on the hinges will increase pro-rata. Therefore, the frame stile where the hinges are to be secured shall be reinforced. The reinforcement may be pieced but shall be of a length to enable the screws attaching the hardware to the frames to be secured into the steel reinforcement. Reinforcement of the sash is to take place where it is necessary for hardware to be secured into steel and always down the locking stile which is to be fit in one continuous piece.

Cills

Maximum cill length without expansion joints is 3000mm, dark coloured cills must be reinforced and vented.

Notes:

- Any sizes stated are either:- sash rebate lengths or the overall frame edge lengths.
- Mullions, transoms and sash sizes are based upon a design wind pressure of 1200Pa.
- For all other exposure categories contact Veka UK Group Technical Department for advice and guidance.
- When using cockspur handles, locally reinforce the area where the handle is to be secured.
- Use cavity locking wedges, run up blocks and glass packers as detailed in the manual.
- Consider glass weight - This specification is based upon 28mm DGUs using 4mm float / toughened glass.
- All dark coloured profiles must be fully reinforced with a maximum fixing centre distance of 300mm.
- Doorsets with glass or solid panels at low levels can be vulnerable to attack, therefore additional security retention devices may be required.

Combined Steel Iyy Values

2

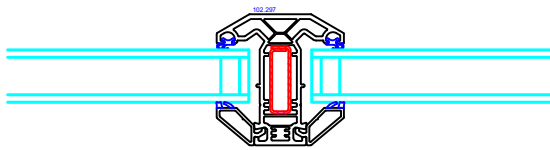

102297 68mm Mullion (Fixed - Fixed)

$I_{yy} = 3.19\text{cm}^4$

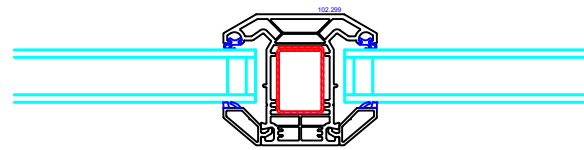

102299 82mm Mullion (Fixed - Fixed)

$I_{yy} = 3.79\text{cm}^4$ (1.2mm) / 5.04cm^4 (3.0mm)

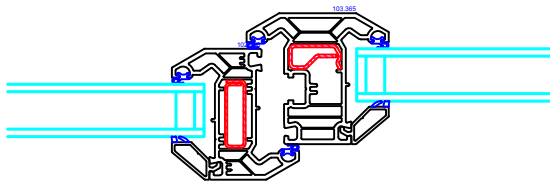

102298/103365 68mm Mullion Casement (Fixed - Sash)

$I_{yy} = 5.10\text{cm}^4$

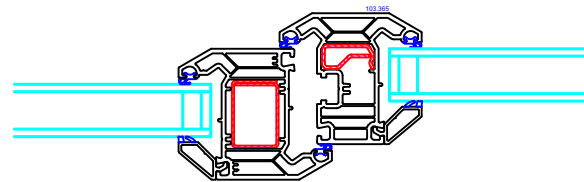

103364/103365 82mm Mullion Casement (Fixed - Sash)

$I_{yy} = 5.59\text{cm}^4$ (1.2mm) / 6.84cm^4 (3.0mm)

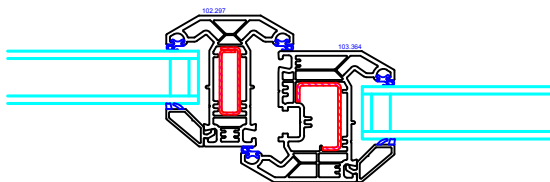

102297/103364 68mm Mullion Tilt & Turn (Fixed - Sash)

$I_{yy} = 5.10\text{cm}^4$

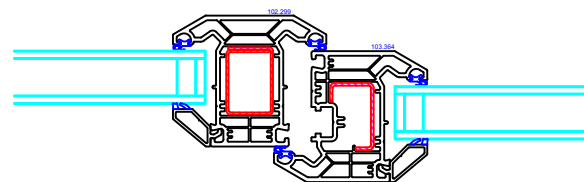

102299/103364 82mm Mullion Tilt & Turn (Fixed - Sash)

$I_{yy} = 5.78\text{cm}^4$ (1.2mm) / 7.03cm^4 (3.0mm)

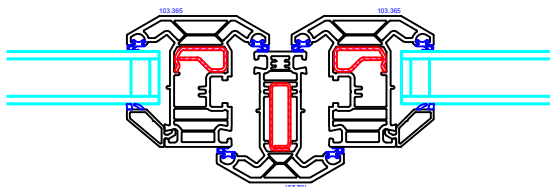

102297/103365 68mm Mullion Casement (Sash - Sash)

$I_{yy} = 5.21\text{cm}^4$

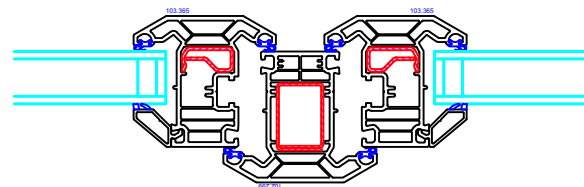

102299/103365 82mm Mullion Casement (Sash - Sash)

$I_{yy} = 5.96\text{cm}^4$ (1.2mm) / 7.21cm^4 (3.0mm)

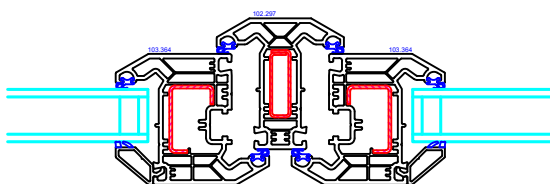

102297/103364 68mm Mullion Tilt & Turn (Sash - Sash)

$I_{yy} = 5.21\text{cm}^4$

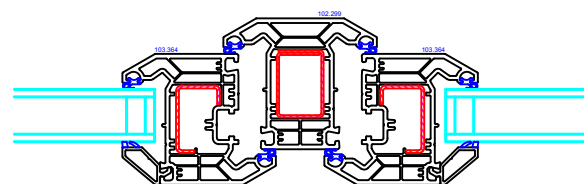

102299/103364 82mm Mullion Tilt & Turn (Sash - Sash)

$I_{yy} = 5.96\text{cm}^4$ (1.2mm) / 7.21cm^4 (3.0mm)

The suitability and required "I" value of mullions depends on frame type, design, size and location. For advice using the above values please refer to the VEKA "Reinforcement Guide Lines" manual or contact the VEKA Technical Team.

The above theoretical I values were calculated based upon indicative testing carried out in the Technical Workshop as detailed in test report WT235.

The I value is based upon the deflection experienced on frames which were fully reinforced and glazed with 4:20:4 glazed units when tested up to 2000Pa.

Profile Combinations.

Casement Window.

Internally Beaded

102297 68mm T Mullion

102298 68mm Z Mullion

103365 76mm Casement Sash

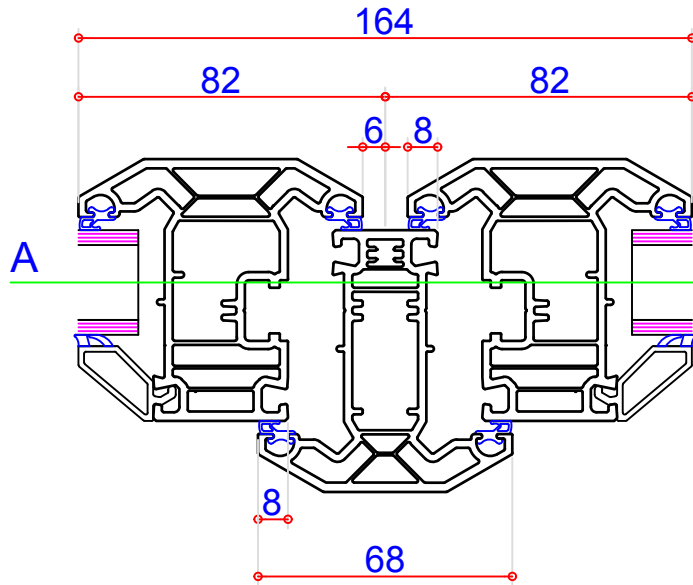
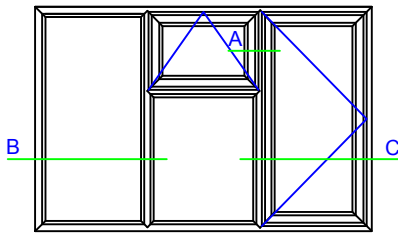

2

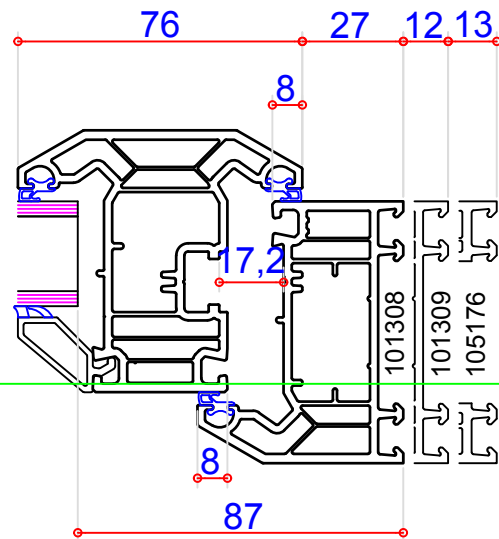
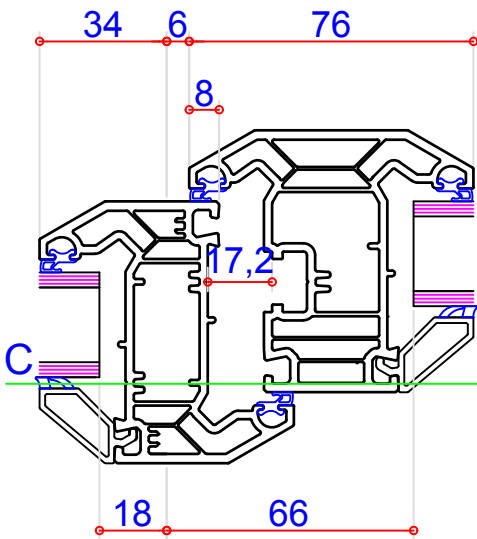
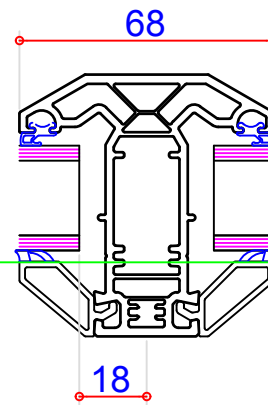
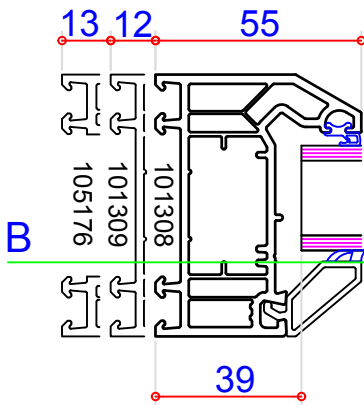

Reinforcement sections removed for clarity.

Profile Combinations.

Tilt & Turn Window.

Internally Beaded

102299 82mm T Mullion

103364 82mm Tilt & Turn Sash

2

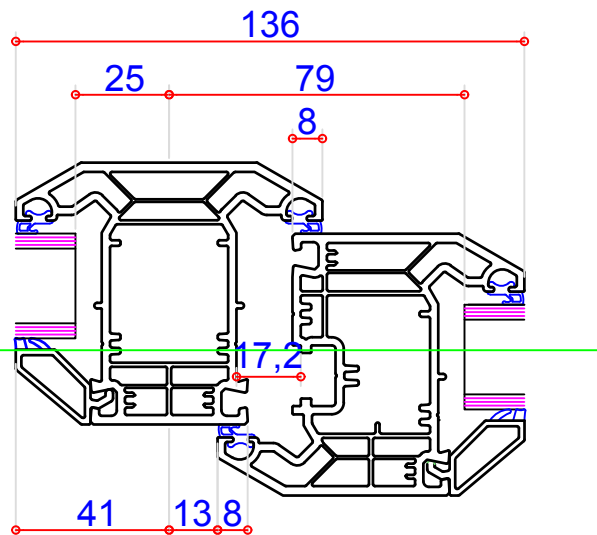
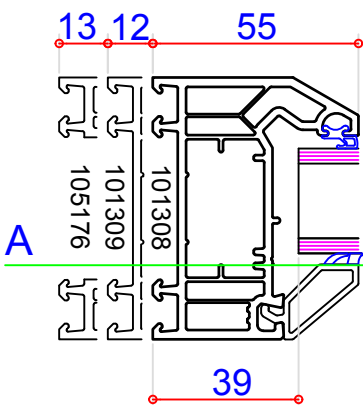
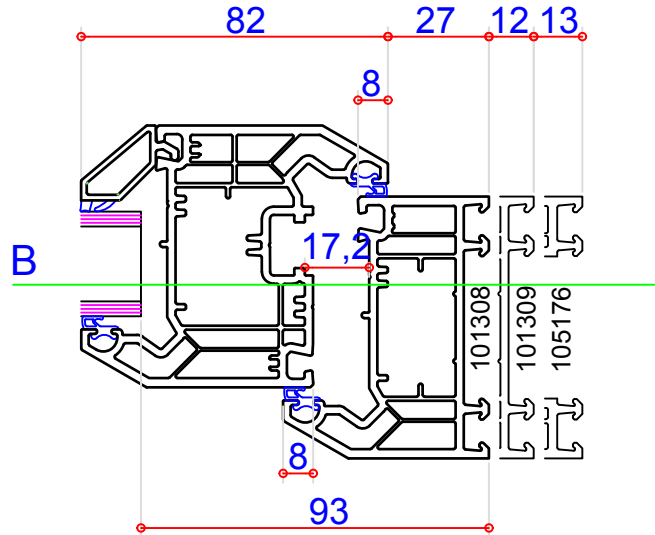
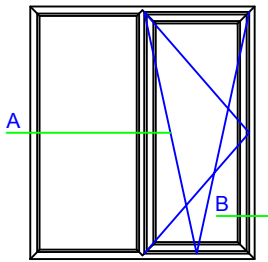

Reinforcement sections removed for clarity.

Profile Combinations.

Open In Residential Door.

Internally Beaded

103366 115mm Z Door Sash

103367 115mm T Midrail

102299 82mm T Mullion

2

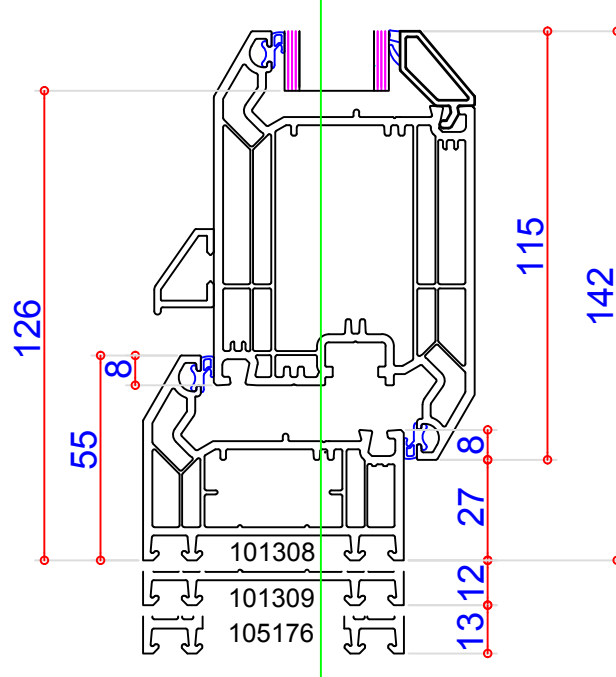
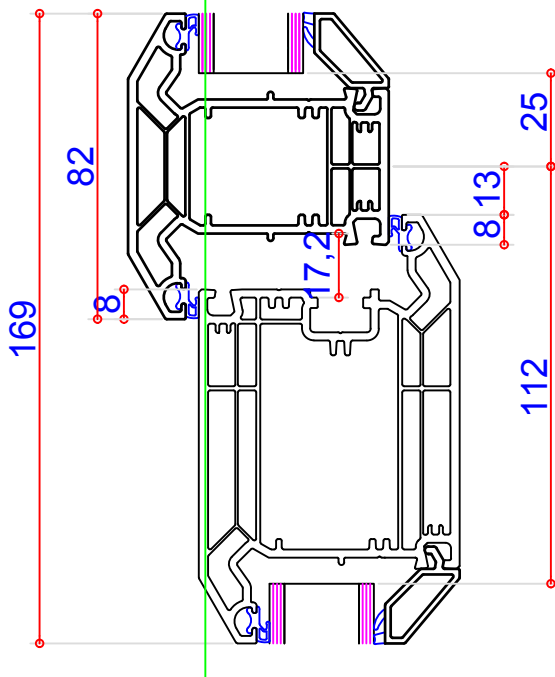
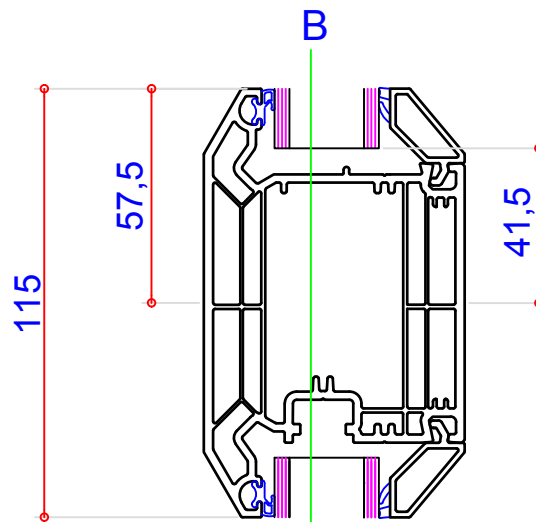
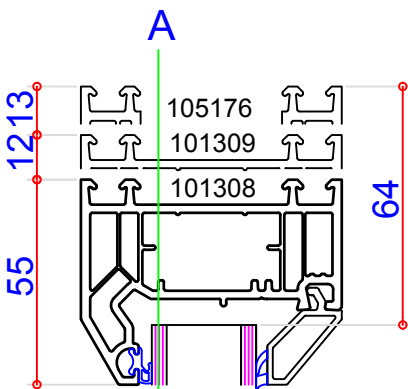
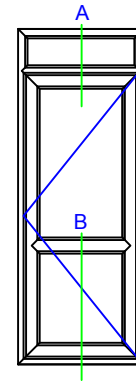

Reinforcement sections removed for clarity.

Profile Combinations.

Open Out Residential Door.

Internally Beaded

103367 115mm T Door Sash

103367 115mm T Midrail

103364 82mm Z Mullion

2

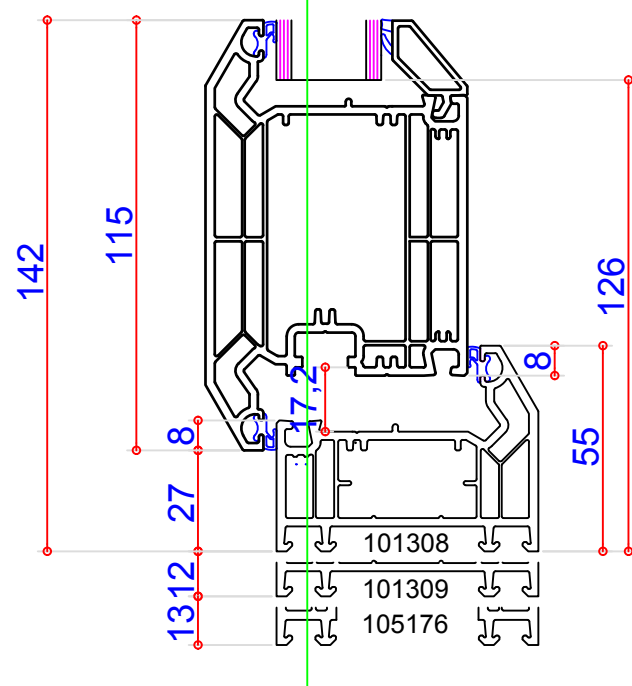
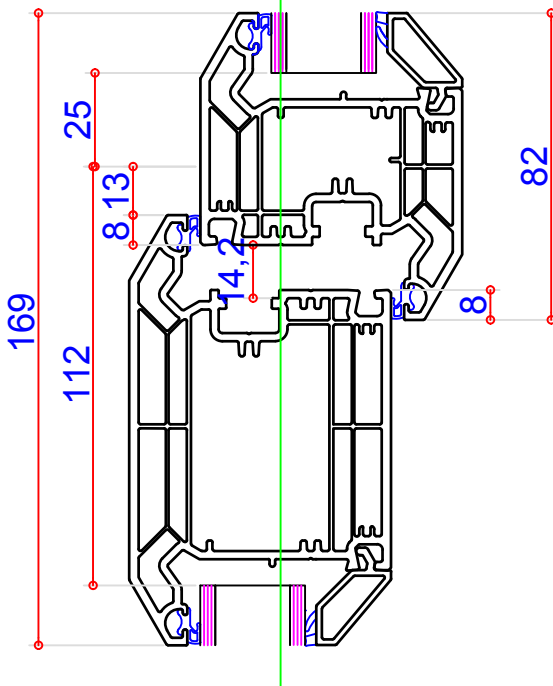
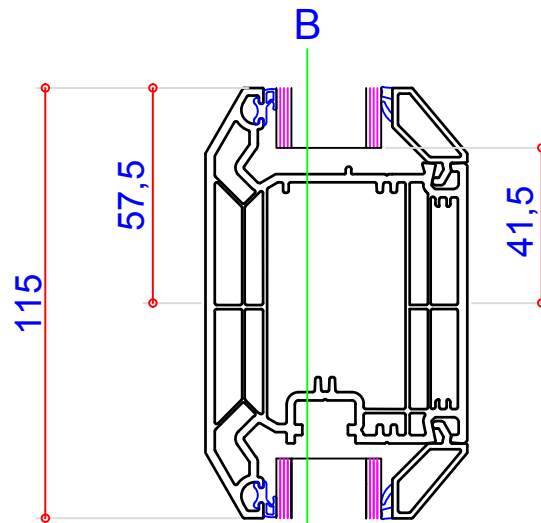
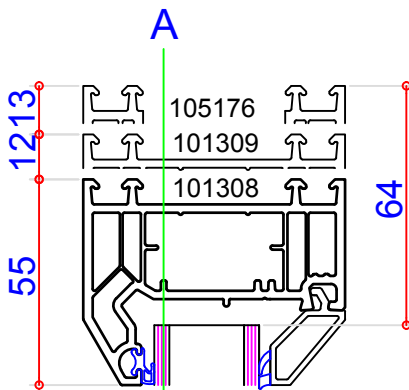
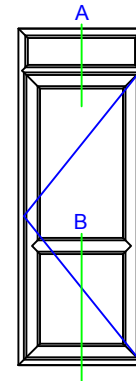

Reinforcement sections removed for clarity.

Profile Combinations.

Alternative Transoms

Open Inwards

68mm T Mullion 102297

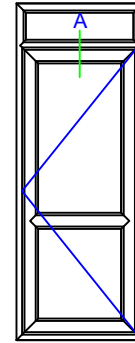
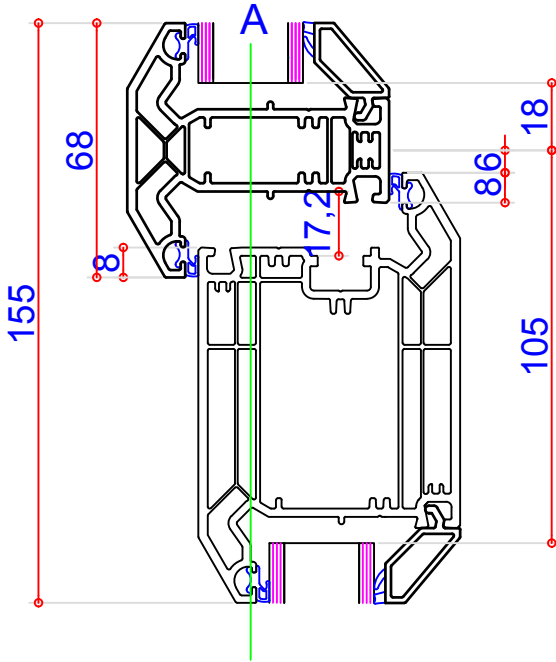

2

Open Outwards

68mm Z Mullion 102298

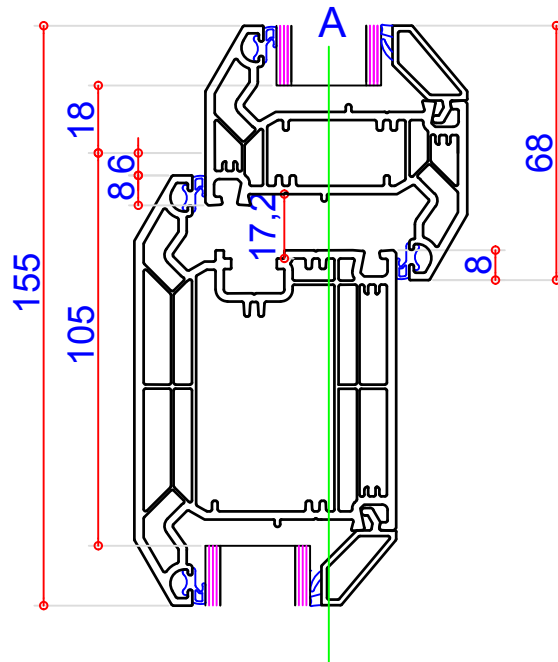

Open Inwards

76mm Casement Sash/T Mullion 103365

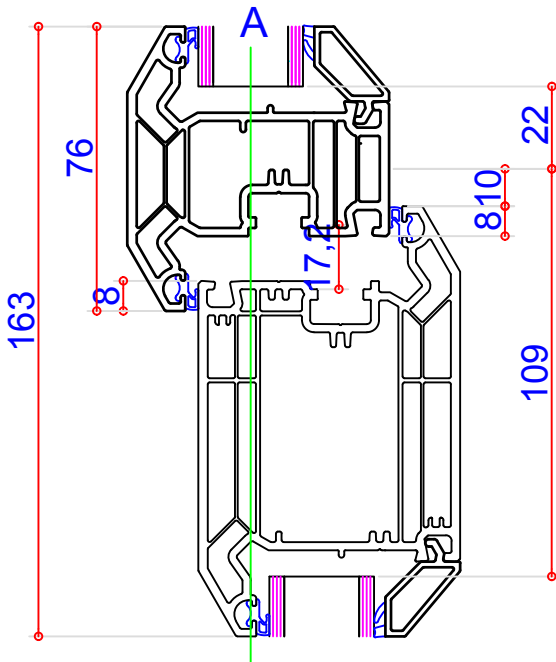

Reinforcement sections removed for clarity.

Profile Combinations.

Low Thresholds

Open Inwards

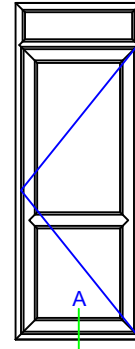
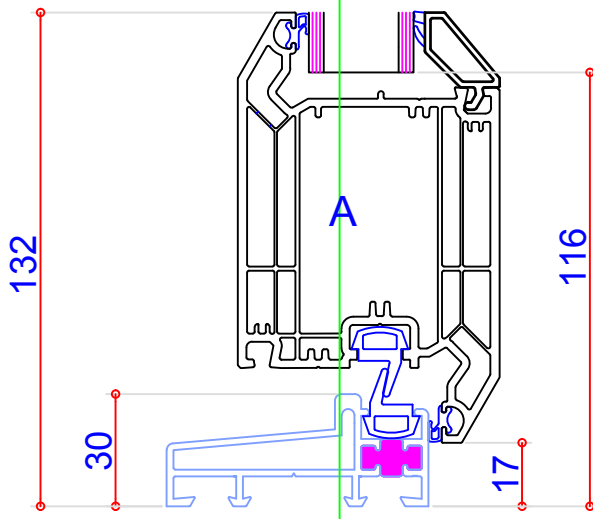

2

704829 Is not recommended for open in doors due to the possibility of water ingress due to its poor weather performance.

Open Outwards

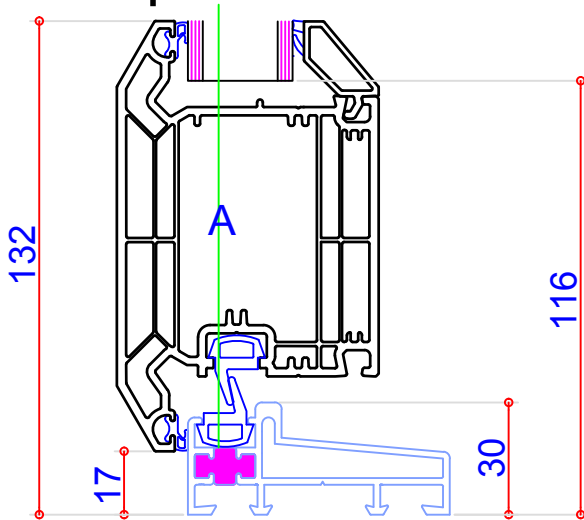

Open Outwards

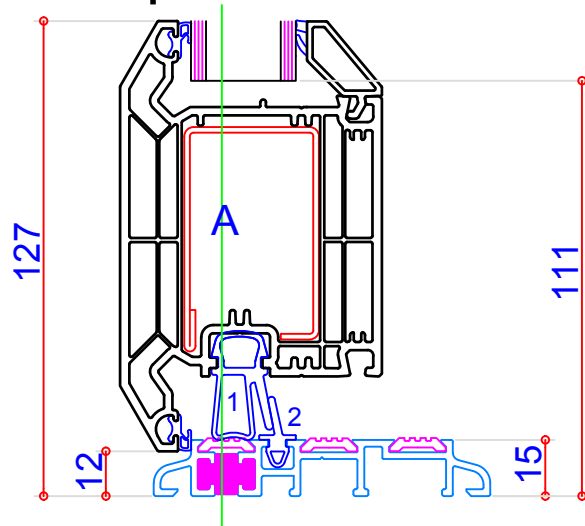

- 704092 Standard Low Threshold
- 712005 Threshold Seal
- 103366 115mm Z Door sash (Open In)
- 103367 115mm T Door Sash (Open Out)

- Open Out Residential Door Part M Low Threshold.
- 103367 115mm T Door Sash (Open Out)
- 704289 Part M Low Threshold
- 712087 Threshold Seal 1
- 712086 Threshold Seal 2
- 709047 Threshold Strip

Reinforcement sections removed for clarity.

Profile Combinations.

Door - French Mullion.

- 103366 115mm Z Door sash (Open In)
- 103367 115mm T Door Sash (Open Out)
- 104396 French Door Mullion Adapter
- 102297 68mm T Mullion

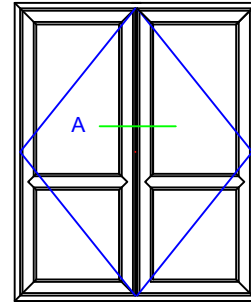

2

Door - Open Inwards

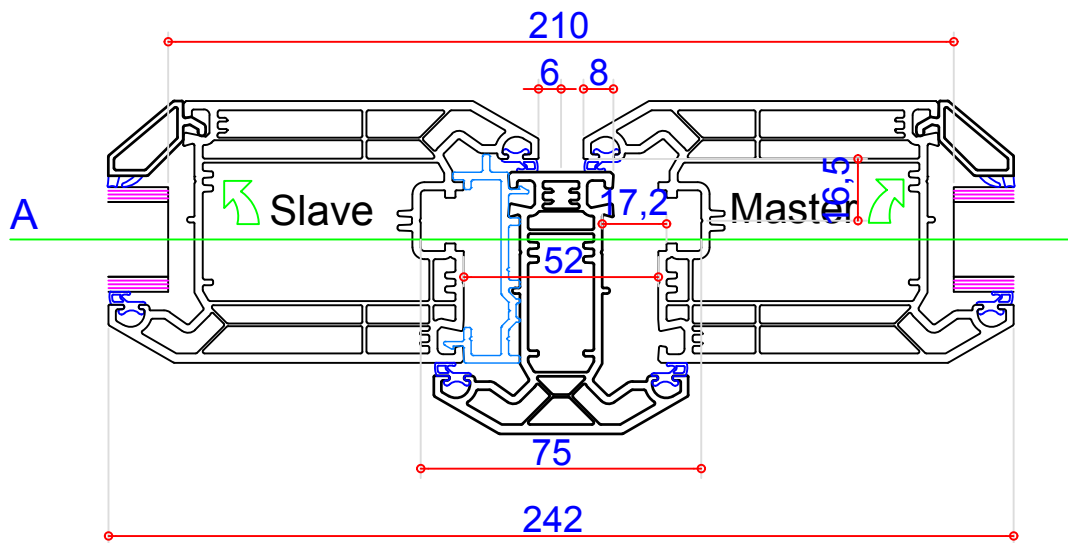

Door - Open Outwards

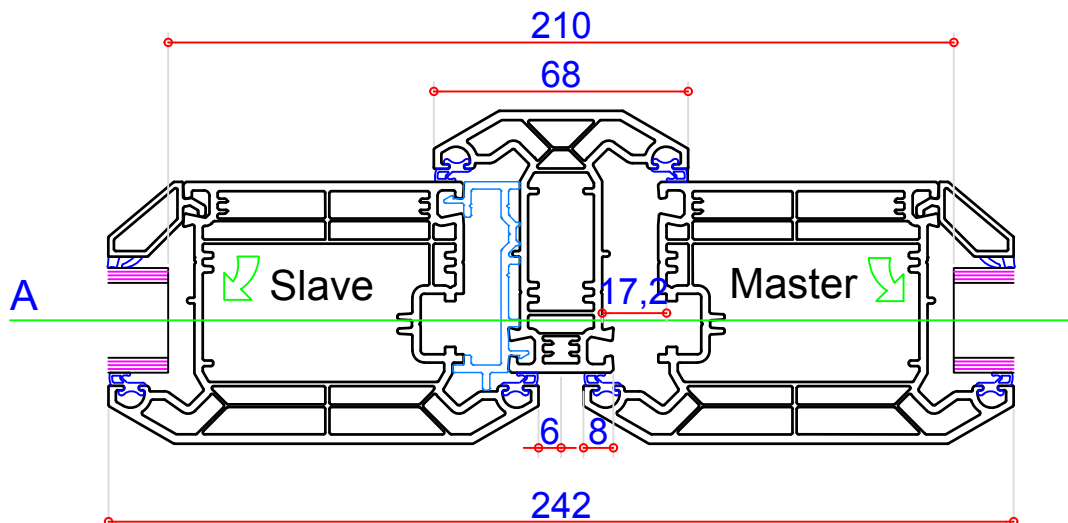

Reinforcement sections removed for clarity.

Profile Combinations.

Window - French Mullion.

103367 76mm T Casement Sash

104397 French Window Mullion Adapter

102297 68mm T Mullion

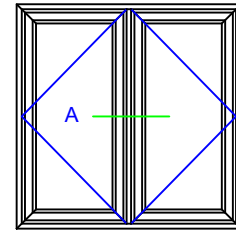

2

Casement Window - Open Out.

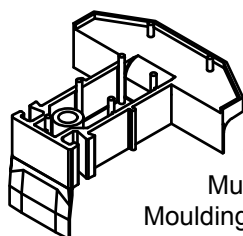
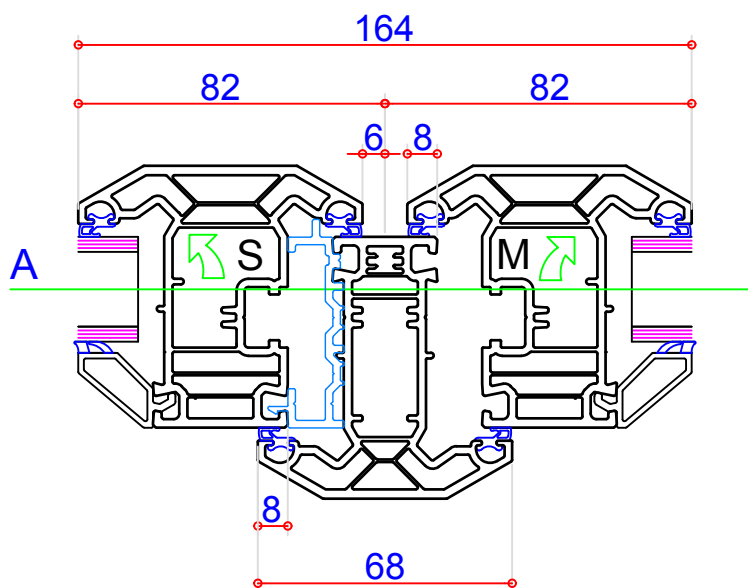

109057 False
Mullion End Cap
Moulding (for 102297)

Reinforcement sections removed for clarity.

Building Regulations 2000 Part B Fire Safety (Part E Scotland)

The following information is intended only as a guide for window surveyors/manufacturers based upon the specified issue of the Building Regulations, the profiles and gearing (if applicable) shown on the sheet. It is the responsibility of the surveyor/ manufacturer to ensure that the finished window fully complies with the requirements of the regulations and whilst every effort has been made to ensure that the information given is correct, Veka plc do not accept any liability for any errors or omissions contained herein.

2

Extract taken from 'Approved Document B; Section B1:Page 24, Section 2.11:2000'

The Regulation States: The window should have an unobstructed openable area that is at least 0.33m² and at least 450mm high or 450mm wide (the route through the window may be at an angle rather than straight through). The bottom of the openable area should be not more than 1100mm above the floor.

How to determine minimum sash sizes

Table 1 shows the minimum permissible frame widths that allow a clear width of 450mm with the sash open at 90°. Determine where the sash is to be situated within the frame and the frame profiles to obtain the minimum size.

Table 2 shows the minimum frame heights that are permissible when combined with the widths shown in Table 1 to allow a minimum opening area of 0.33 sq/m. Again, determine where the sash is situated within the frame and the frame profile sizes.

Tilt & Turn Fire Escape Windows

Minimum overall sash size = 538mm wide x 791mm high.

Table 1

Min Frame Width	55mm	67mm	80mm
Frame To Frame	>592	>616	>642
Frame To Mullion	>578	>590	>603
Mullion To Mullion	>564	>564	>564

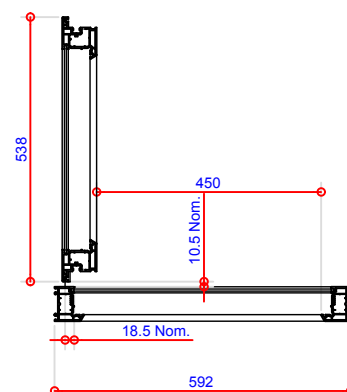
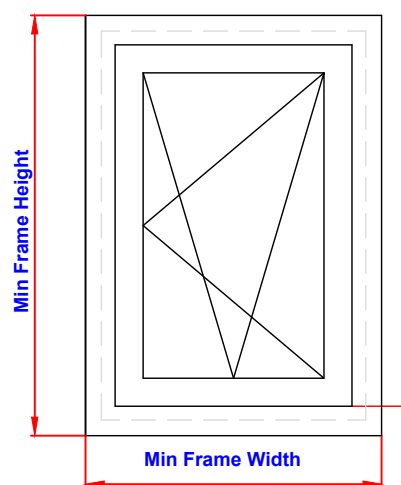

Table 2

Min Frame Height	55mm	67mm	80mm
Frame To Frame	>845	>869	>895
Frame To Transom	>817	>817	>817
Transom To Transom	>831	>843	>856



The information is based on the use of a typical face mounted hinge using the 103364 sash profile and 102299 Transom/Mullion.

Casement Fire Escape Windows

Based On Securistyle 16" Standard Side Hung Stay Using Sash 103365 and 102297/102298 Transom/Mullion.

Sash Weight = * 16kg at sash size of 716 w x 794 h (Fully Reinforced) Max Sash Weight not to exceed 24kg.

Min Overall Sash Size = 716mm Wide X 791mm High

Table 1

Min Frame Width	55mm	67mm	80mm
Frame To Frame	>620	>644	>670
Frame To Mullion	>595	>611	>624
Mullion To Mullion	>570	>578	>578

Table 2

Min Frame Height	55mm	67mm	80mm
Frame To Frame	>820	>863	>885
Frame To Transom	>824	>836	>849
Transom To Transom	>817	>817	>817

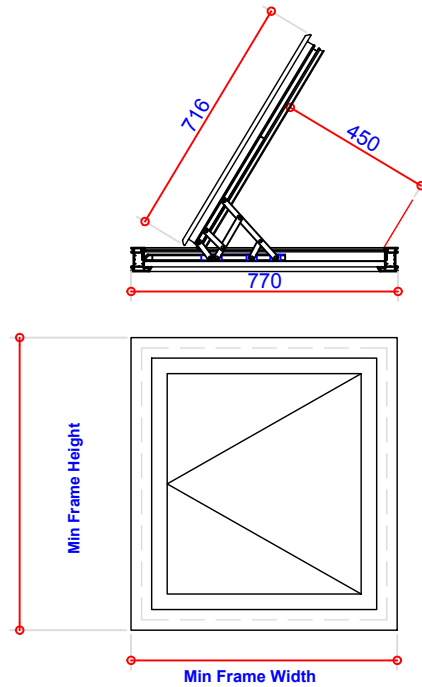

2

Based On Securistyle 16" Egress Side Hung Stay Using Sash 103365 and 102297/102298 Transom/Mullion.

Sash Weight = * 13.25kg at sash size of 566 w x 796 h (Fully Reinforced) Max Sash Weight not to exceed 24kg.

Min Overall Sash Size = 566mm Wide X 796mm High

Table 1

Min Frame Width	55mm	67mm	80mm
Frame To Frame	>620	>644	>670
Frame To Mullion	>595	>611	>624
Mullion To Mullion	>570	>578	>578

Table 2

Min Frame Height	50mm	60mm	70mm
Frame To Frame	>850	>874	>900
Frame To Transom	>825	>841	>854
Transom To Transom	>800	>808	>808

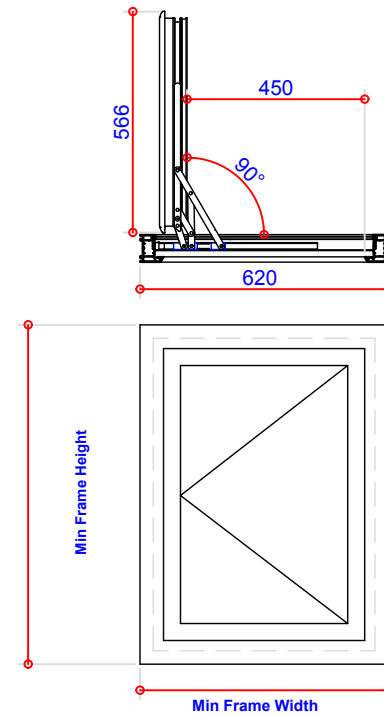

* Approx Weight Based On 4/16/4 or 4/20/4 Glass Units Sash Weight = Glass Area @ 20 Kg per metre/2, plus Sash Perimeter Dimension (mm) x .0026 Kg per mm

Reduction Factors - Casement

103365 Casement Sash.

102297/102298 T/Z Transom/Mullion

101308	Frame	55
101309	Frame	67
105176	Frame	80
102297	Mull (T)	68
102298	Mull (Z)	68
103365	Sash	76

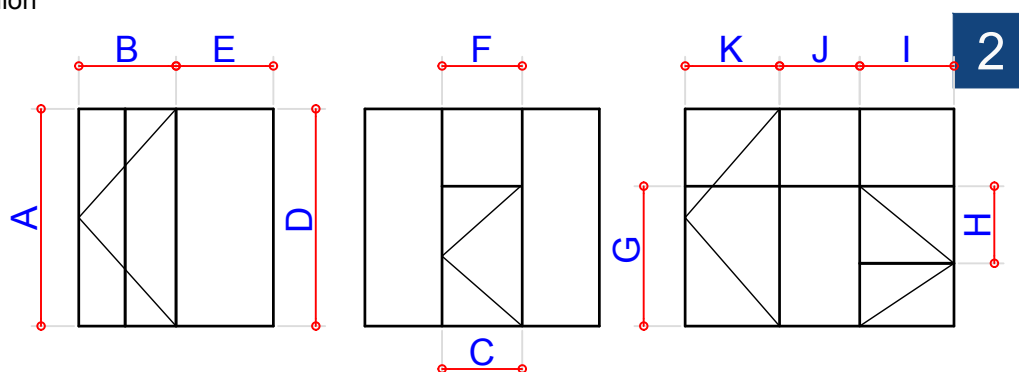

NOTE: Dimensions are in millimeters and do **NOT** include weld allowance.

Section		55mm	Glass	67mm	Glass	80mm	Glass
Sash size frame to frame	A	-54	-174	-78	-198	-104	-224
Sash size frame to mullion	B	-33	-153	-45	-165	-58	-178
Sash size mullion to mullion	C	-12	-132	-12	-132	-12	-132
Glass size frame to frame	D		-78		-102		-128
Glass size frame to mullion	E		-57		-69		-82
Glass size mullion to mullion	F		-36		-36		-36
Glass size frame to tran in sash	G		-105		-117		-130
Glass size tran to tran in sash	H		-84		-84		-84

Welded transom/mullion size		55mm	Glass	67mm	Glass	80mm	Glass
Frame to frame in frame	A	+26		+2		-24	
Frame to mullion in frame	I	+47		+35		+22	
Transom to mullion in frame	J	+68		+68		+68	
Frame to frame in sash	A	-70		-94		-120	
Frame to mullion in sash	K	-49		-61		-74	
Transom to transom in sash	C	-28		-28		-28	

Mechanical transom/mullion cut size		55mm	Glass	67mm	Glass	80mm	Glass
Frame to frame in frame	A	-65		-89		-115	
Frame to mullion in frame	I	-44		-56		-69	
Transom to mullion in frame	J	-23		-23		-23	
Frame to frame in sash	A	-20		-185		-211	
Frame to mullion in sash	K	-140		-152		-165	

Reduction Factors - Casement

103365 Casement Sash.

103365 T Transom/Mullion

101308	Frame	55
101309	Frame	67
105176	Frame	80
103365	Mull (T)	76
103365	Sash	76

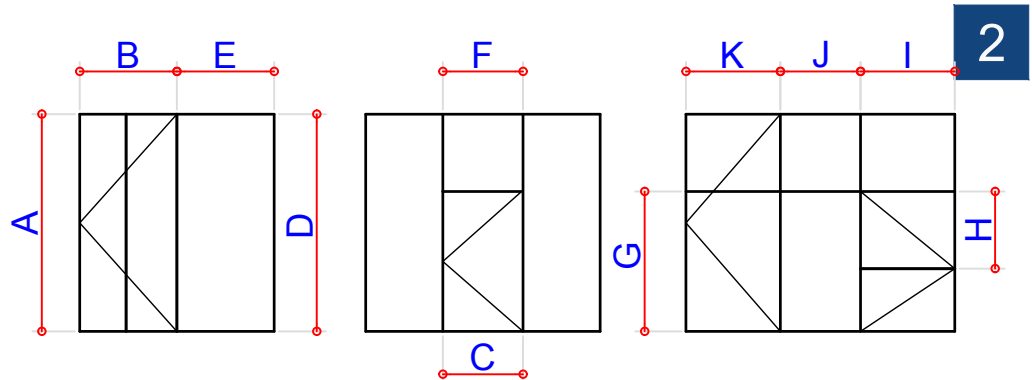

NOTE: Dimensions are in millimeters and do **NOT** include weld allowance.

Section		55mm	Glass	67mm	Glass	80mm	Glass
Sash size frame to frame	A	-54	-174	-78	-198	-104	-224
Sash size frame to mullion	B	-37	-157	-49	-169	-62	-182
Sash size mullion to mullion	C	-20	-140	-20	-40	-20	-140
Glass size frame to frame	D		-78		-102		-128
Glass size frame to mullion	E		-61		-73		-86
Glass size mullion to mullion	F		-44		-44		-44
Glass size frame to tran (sash)	G		-113		-125		-138
Glass size tran to tran (sash)	H		-96		-96		-96

Welded Transom/Mullion size		55mm	Glass	67mm	Glass	80mm	Glass
Frame to frame in frame	A	+42		+18		-3	
Frame to mullion in frame	I	+59		+47		+34	
Transom to mullion in frame	J	+76		+76		+76	
Frame to frame in sash	A	-54		-78		-104	
Frame to mullion in sash	K	-37		-49		-62	
Transom to mullion in sash	C	-20		-20		-20	

Mechanical transom/mullion cut size		55mm	Glass	67mm	Glass	80mm	Glass
Frame to frame in frame	A	-65		-89		-115	
Frame to mullion in frame	I	-48		-60		-73	
Transom to mullion in frame	J	-31		-31		-31	
Frame to frame in sash	A	-161		-185		-211	
Frame to mullion in sash	K	-144		-156		-169	

Reduction Factors - Casement

103365 Casement Sash.

102299/103364 T/Z Transom/Mullion

101308	Frame	55
101309	Frame	67
105176	Frame	80
102299	Mull (T)	82
103364	Mull (Z)	82
103365	Sash	76

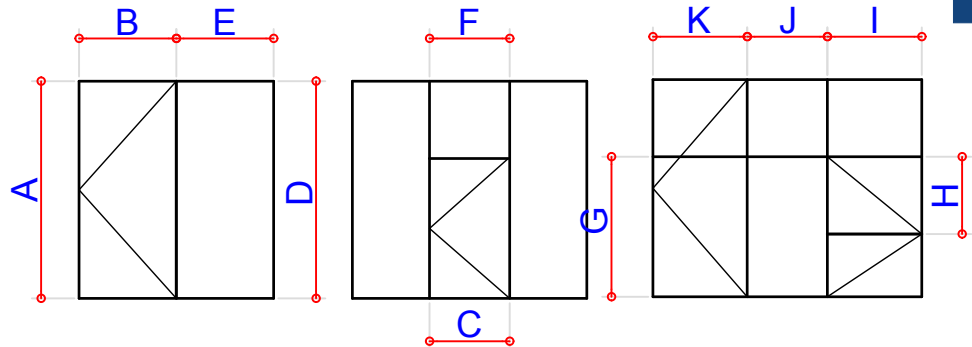

NOTE: Dimensions are in millimeters and do **NOT** include weld allowance.

Section		55mm	Glass	67mm	Glass	80mm	Glass
Sash size frame to frame	A	-54	-174	-78	-198	-104	-224
Sash size frame to mullion	B	-40	-160	-52	-172	-65	-185
Sash size mullion to mullion	C	-26	-146	-26	-146	-26	-146
Glass size frame to frame	D	-78		-102		-128	
Glass size frame to mullion	E	-64		-76		-89	
Glass size mullion to mullion	F	-50		-50		-50	
Glass size frame to tran in sash	G	-112		-124		-137	
Glass size tran to tran in sash	H	-98		-98		-98	

Welded transom/mullion size		55mm	Glass	67mm	Glass	80mm	Glass
Frame to frame in frame	A	+54		+30		+4	
Frame to mullion in frame	I	+68		+56		+43	
Transom to mullion in frame	J	+82		+82		+82	
Frame to frame in sash	A	-42		-66		-92	
Frame to mullion in sash	K	-20		+8		-5	
Transom to mullion in sash	C	+34		+34		+34	

Mechanical Mull cut size		55mm	Glass	67mm	Glass	80mm	Glass
Frame to frame in frame	A	-65		-89		-115	
Frame to transom in frame	I	-51		-63		-76	
Transom to transom in frame	J	-37		-37		-37	
Frame to frame in sash	A	-161		-185		-211	
Frame to transom in sash	K	-119		-131		-144	

Reduction Factors - French Casement

103365 Casement Sash.
102297 T Transom/Mullion

101308	Frame	55
101309	Frame	67
105176	Frame	80
102297	French Mull (T)	68
102297	Mull (T)	68
103365	Sash	76

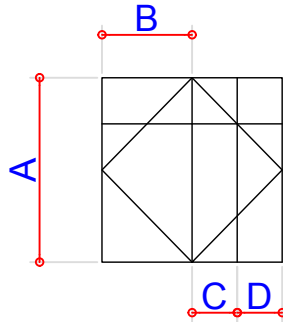

2

NOTE: Dimensions are in millimeters and do **NOT** include weld allowance.

Section		55mm	Glass	67mm	Glass	80mm	Glass
Sash size frame to frame	A	-54	-174	-78	-198	-104	-224
Sash size frame to french mullion	B	-33	-153	-45	-165	-58	-178
Glass size mull to french mull in sash	C		-84		-84		-84
Glass size frame to f mull	D		-105		-117		-130

Welded transom/mullion size		55mm	Glass	67mm	Glass	80mm	Glass
Frame to frame in sash	A	-70		-94		-120	
Frame to french mullion in sash	B	-49		-61		-74	
Mullion to french mullion in sash	C	+20		+20		+20	
Frame to false mullion in sash	D	-1		-13		-26	

Mechanical transom/mullion cut size		55mm	Glass	67mm	Glass	80mm	Glass
Frame to frame in sash	A	-161		-185		-211	
Frame to french mullion in sash	B	-140		-152		-165	
Mullion to french mullion in sash	C	-71		-71		-71	
Frame to mullion in sash	D	-92		-104		-117	

French mullion cut size		55mm	Glass	67mm	Glass	80mm	Glass
Frame to frame		-126		-150		-176	

Reduction Factors - Tilt & Turn

103364 Tilt & Turn Sash.

102299/103364 T/Z Transom/Mullion

102297 False Mullion

101308	Frame	55
101309	Frame	67
105176	Frame	80
102299	Mull (T)	82
103364	Mull (Z)	82
103364	Sash	82

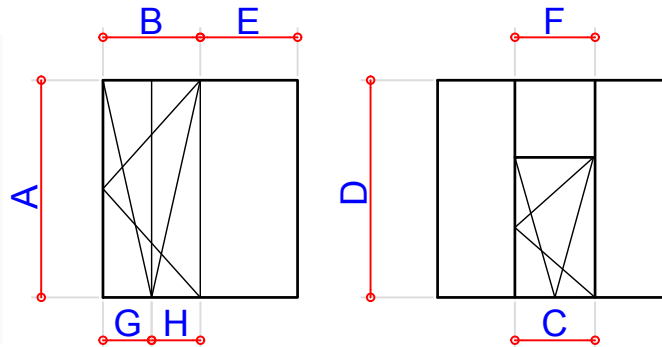

2

NOTE: Dimensions are in millimeters and do **NOT** include weld allowance.

Section		55mm	Glass	67mm	Glass	80mm	Glass
Sash size frame to frame	A	-54	-186	-78	-210	-104	-236
Sash size frame to mullion	B	-40	-172	-52	-184	-65	-197
Sash size mullion to mullion	C	-26	-158	-26	-158	-26	-158
Glass size frame to frame	D		-78		-102		-128
Glass size frame to mullion	E		-64		-76		-89
Glass size mullion to mullion	F		-50		-50		-50
Glass size frame to f mullion	G		-118		-130		-143
Glass size tran to f mullion	H		-104		-104		-104

Welded transom/mullion size		55mm	Glass	67mm	Glass	80mm	Glass
Frame to frame	A	+54		+30		+4	
Frame to mullion	E	+68		+56		+43	
Transom to mullion	F	+82		+82		+82	
Frame to frame in sash	A	-54		-78		-104	
Frame to mullion in sash	B	-40		-52		-65	
Mullion to mullion in sash	C	-54		-54		-54	

Mechanical Tran/Mull out size		55mm	Glass	67mm	Glass	80mm	Glass
Frame to frame in frame	D	-65		-89		-115	
Frame to mullion in frame	E	-51		-63		-76	
Mullion to mullion in frame	F	-37		-37		-37	
Frame to frame in sash	A	-173		-197		-223	
Frame to mullion in sash	B	-159		-171		-184	
Mullion to mullion in sash	C	-145		-145		-145	

Reduction Factors - French Tilt & Turn

103364 Tilt & Turn Sash.
102297 T Transom/Mullion
102299 False Tran/Mullion

101308	Frame	55
101309	Frame	67
105176	Frame	80
102297	French mull (T)	68
102299	Mull (T)	82
103364	Sash	82

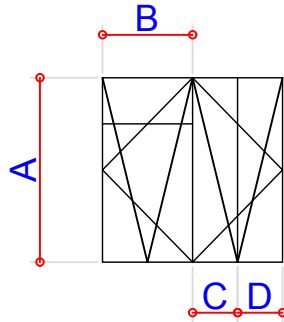

2

NOTE: Dimensions are in millimeters and do **NOT** include weld allowance.

Section		55mm	Glass	67mm	Glass	80mm	Glass
Sash size frame to frame	A	-54	-186	-78	-210	-104	-236
Sash size frame to french mullion	B	-33	-165	-45	-177	-58	-190
Glass size french mull to mull in sash	C		-90		-90		-90
Glass size frame to f mull in sash	D		-111		-123		-136

Welded Mullion size		55mm	Glass	67mm	Glass	80mm	Glass
Frame to frame in sash	A	-54		-78		-104	
Frame to mullion in sash	D	+14		+2		-11	
French mullion to mullion in sash	C	+35		+23		+10	
Frame to French mullion in sash	B	-35		-45		-58	

Mechanical Mull cut size		55mm	Glass	67mm	Glass	80mm	Glass
Frame to frame in sash	A	-173		-197		-223	
Frame to mullion in sash	D	-105		-117		-130	
French mullion to mull in sash	C	-84		-84		-84	
Frame to French mullion in sash	B	-152		-164		-177	

French mullion cut size		55mm	Glass	67mm	Glass	80mm	Glass
Frame to frame	A	-126		-150		-176	

Reduction Factors - Residential Door

103366/103367 Door Sash

103367 Midrail

102299/103364 Mullion

101309	Frame	67
105176	Frame	80
102299	Mull (T)	82
103364	Mull (Z)	82
103366	Sash (Z)	115
103367	Sash (T)	115
103367	Midrail	115
704289	15mm Ali	15
704092	30mm Ali	30

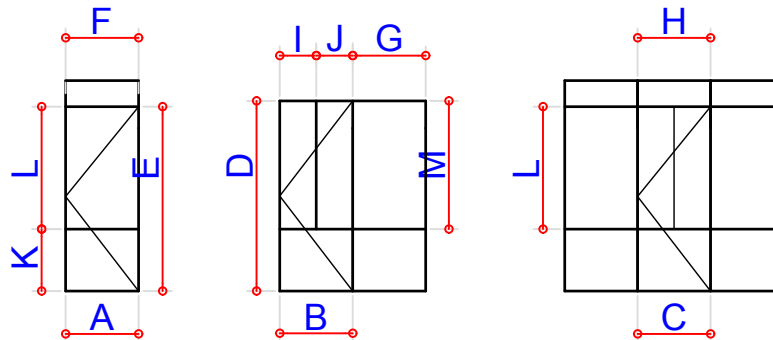

2

NOTE: Dimensions are in millimeters and do **NOT** include weld allowance.

Section			67mm	Glass	80mm	Glass
Sash size	Frame to frame	A	-78	-276	-104	-302
Sash size	Frame to mullion	B	-52	-250	-65	-263
Sash size	Threshold to frame (15mm)	D	-51	-249	-64	-262
Sash size	Threshold to Transom (15mm)	E	-25	-223	-25	-223
Sash size	Threshold to frame (30mm)	D	-56	-254	-69	-267
Sash size	Threshold to Transom (30mm)	E	-30	-228	-30	-228
Glass size	Frame to frame in frame	F		-102		-128
Glass size	Frame to mullion in frame	G		-76		-89
Glass size	Mullion to mullion in frame	L		-50		-50
Glass size	Frame to mullion in sash	I		-163		-176
Glass size	Mullion to mullion in sash	J		-137		-137
Glass size	15mm Threshold to midrail in sash	K		-152		-152
Glass size	30mm Threshold to midrail in sash	K		-157		-157
Glass size	Transom to midrail in sash	L		-153		-153
Glass size	Frame to midrail in sash	M		-179		-192

102299/103364 welded transom/mullion Size			67mm	Glass	80mm	Glass
Frame to frame in frame	D	+30			+4	
Frame to mullion in frame	G	+56			+43	
Mullion to mullion in frame	H	+82			+82	
Frame to midrail in sash	M	-31			-44	
Transom to midrail in sash	L	-5			-5	

Reduction Factors - Residential Door Continued

103366/103367 Door Sash

103367 Midrail

102299/103364 Mullion

101309	Frame	67
105176	Frame	80
102299	Mull (T)	82
103364	Mull (Z)	82
103366	Sash (Z)	115
103367	Sash (T)	115
103367	Midrail	115
704289	15mm Ali	15
704092	30mm Ali	30

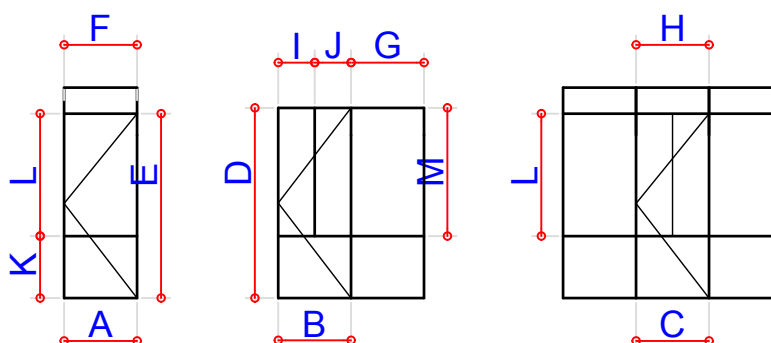

2

NOTE: Dimensions are in millimeters and do **NOT** include weld allowance.

103367 Midrail Size Welded		67mm	Glass	80mm	Glass
Frame to frame in sash	A	-78		-104	
Frame to mullion in sash	B	-52		-65	
Mullion to mullion in sash	C	-26		-26	
Frame to frame in frame	F	+96		+70	
Frame to mullion in frame	G	+122		+109	

Mechanical Mullion/Midrail Cut Size		67mm	Glass	80mm	Glass
Frame to frame in frame	F	-89		-115	
Frame to mullion in frame	G	-63		-76	
Mullion to mullion in frame	H	-37		-37	
Frame to frame in sash	A	-263		-289	
Frame to mullion in sash	B	-237		-250	
Mullion to mullion in sash	C	-211		-211	
Frame to midrail in sash	M	-167		-180	
Transom to midrail in sash	L	-141		-141	

Reduction Factors - French Door

103366/103367 Door Sash

103367 Midrail

102299/103364 Mullion

102297 False Mullion

101309	Frame	67
105176	Frame	80
102297	French Mull (T)	68
102299	Mull (T)	82
103364	Mull (Z)	82
103366	Sash (Z)	115
103367	Sash (T)	115
103367	Midrail	115
704289	15mm Ali	15

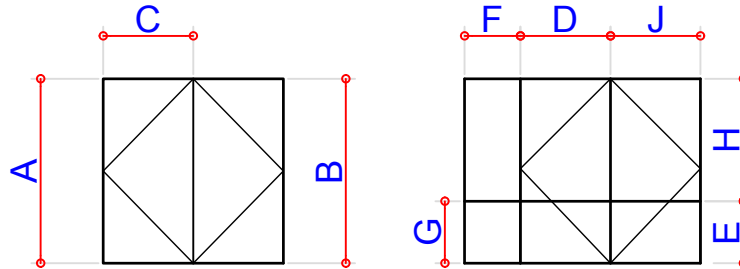

2

NOTE: Dimensions are in millimeters and do **NOT** include weld allowance.

Section			67mm	Glass	80mm	Glass
Sash size	Frame to frame	A	-78	-276	-104	-302
Sash size	Threshold (30mm) to frame	B	-55	-253	-68	-266
Sash size	Frame to french mullion	C	-45	-243	-58	-256
Sash size	Mullion to french mullion	D	-19	-217	-19	-217
Glass size	Threshold (30mm) to midrail	E		-156		-156
Glass size	Frame to frame			-102		-128
Glass size	Frame to mullion	F		-76		-89
Glass size	Frame to midrail in frame	G		-93		-106
Glass size	Frame to midrail in sash	H		-180		-193

102299/103364 welded transom/mullion sash			67mm	Glass	80mm	Glass
Frame to frame in frame	A		+30		+4	
Frame to mullion in frame	F		56		+43	
Frame to french mullion in sash	J		-111		-124	
Mullion to french mullion in sash	D		-85		-85	

Reduction Factors - French Door Continued

- 103366/103367 Door Sash
- 103367 Midrail
- 102299/103364 Mullion
- 102297 False Mullion

101309	Frame	67
105176	Frame	80
102297	F-Mull (T)	68
102299	Mull (T)	82
103364	Mull (Z)	82
103366	Sash (Z)	115
103367	Sash (T)	115
103367	Midrail	115
704289	15mm Ali	15

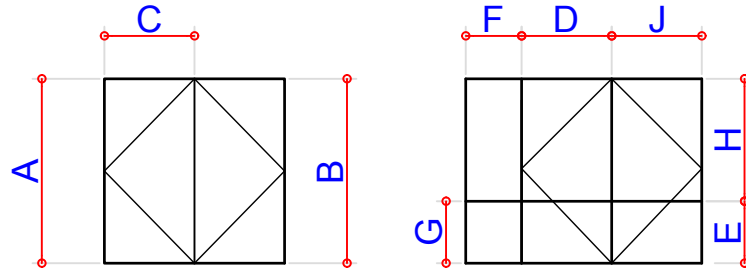

2

NOTE: Dimensions are in millimeters and do **NOT** include weld allowance.

102299/103364 Mechanical transom/mullion Cut Size		67mm	Glass	80mm	Glass
Frame to mullion in frame	F	-63		-76	
Frame to French mullion in sash	J	-230		-243	
Mullion to French mullion in sash	D	-204		-204	

French mullion cut size		67mm	Glass	80mm	Glass
Frame to frame	A	-150		-176	

Weld Test Data - Values in accordance with BS EN 514

2

Corner Weld Test Data									
Product	Values used to calculate as per BS EN 514			Destructive loads as per BS EN 514 (fig 1)		Dimensions to "V" using either 25kg or 50kg as per BS EN 514 (fig 1 & 2)		Destructive load and profile cut size as per BS EN 514 (fig 3)	
	Width	'i' Value (cm ⁴)	'e' Value (mm)	Minimum Load (kg)	Average Load (kg)	BS 7412 25 kg (mm)	BS 7412 50 kg (mm)	Failure Load Min. (kn)	Cut Size (mm)
101308	55	13.80	33.15	28.3	35.4	339	170	1.41	322
101309	67	27.20	39.15	47.2	59.0	567	283	2.42	334
105176	80	46.29	45.35	69.4	86.7	832	416	3.65	347
102297	68	13.24	34.00	32.5	40.6	390	195	1.63	346
102298	68	16.23	34.00	32.4	40.5	389	195	1.63	346
102299	82	33.30	41.00	55.2	69.0	662	331	2.85	360
103364	82	34.50	41.89	56.0	70.0	672	336	2.90	358
103365	76	25.47	38.48	45.0	56.2	540	270	2.30	353
103366	115	116.69	59.50	133.3	166.6	1599	800	7.45	389
103367	115	116.46	59.30	133.5	166.8	1602	801	7.45	389

MANUFACTURE

COMPONENTS

1

DESIGNS AND STATISTICS

2

MANUFACTURE

3

ACCREDITATIONS

4

REVISIONS

5

3.00.1	This page
3.01.1	Drainage
3.02.1	Drainage Continued
3.03.1	Drainage Routes
3.04.1	Drainage Routes Continued
3.05.1	Drainage Routes Continued
3.06.1	Profile Milling Dimensions
3.07.1	Reinforcing
3.08.1	Reinforcing Continued
3.09.1	Mechanical Joint Reinforcing
3.10.1	Mechanical Joint Crucifix
3.11.1	Low Threshold Preparation
3.12.1	Low Threshold Fixing
3.13.1	Screw Specification
3.14.1	Screw Specification Continued
3.15.1	Hardware Specification

Drainage Of Window/Door Frames And Sashes

All horizontal lower rails of frames, transoms, and sashes within a window or door require drainage to allow any water that may enter the rebate a means of escape.

This is achieved by milling entry slots from the upper rebate into the outer profile chamber and escape slots through the base or face of the profile. The exact positions of the entry and exit slots vary depending on the shape of the sections that are being used, and the details are shown on the following pages.

When milling the slots, exercise care not to cut through the wall into the central reinforcement chamber otherwise any water entering will not be able to escape and will corrode the steel.

Some profiles have additional horizontal walls in the chambers and, dependent on the profile and the type of drainage that is required, these walls must be 'broken through'. See the following pages that show the details for profiles in the M70 range.

To prevent air flow from restricting water flow through the drainage slots, they should be offset.

This creates an indirect path through the profile which improves the efficiency of the drainage.

Drainage slots should be 5mm wide x 30mm long, and the offset distance should be 100mm +20mm/-0mm between the entry and exit slots.

Clear any swarf or debris that can build up within the inner chambers when milling has been completed as this will restrict the flow of the water.

3

Slot Positions In Outer Frames

Example Shown
Reverse for opposite hand.

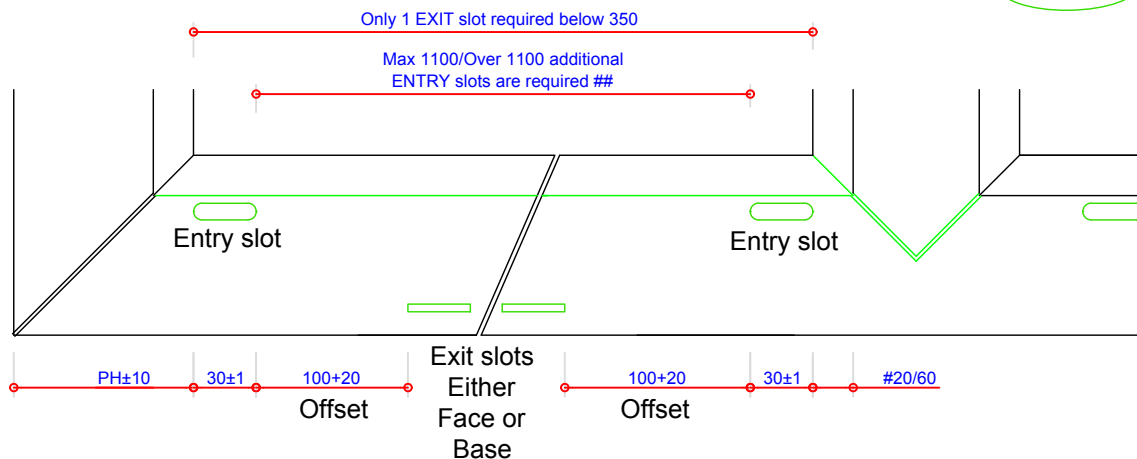
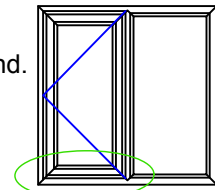

When manufacturing casement windows, the distance from the rebate corner to the entry slot will vary depending on whether an espagnolette or shootbolt locking mechanism is to be fitted because of the keeper and its fixing screw position.

Espagnolette Distance: approx 20mm

Shootbolt Distance: approx 60mm

For French casements below 1100mm additional drainage slots located centrally are recommended.

PH = Profile height.

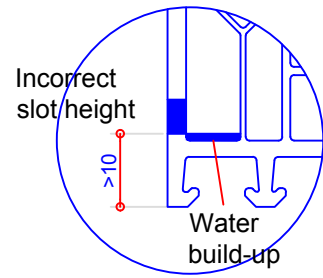
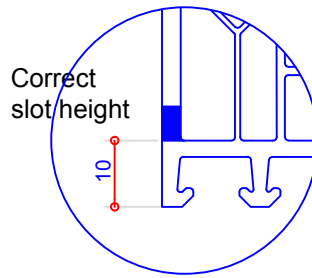
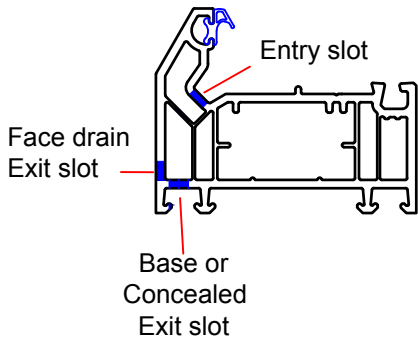

Where possible face drainage slots should be milled at the closest point to the horizontal wall to reduce water build-up.

3

Slot Positions In Transoms

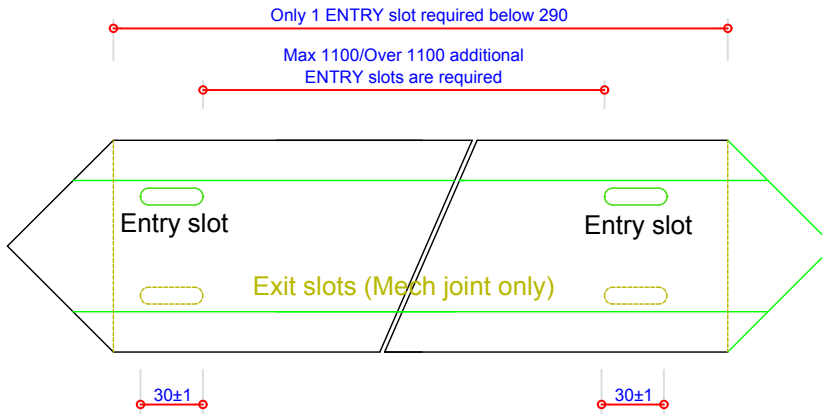

Slot Positions In Sashes

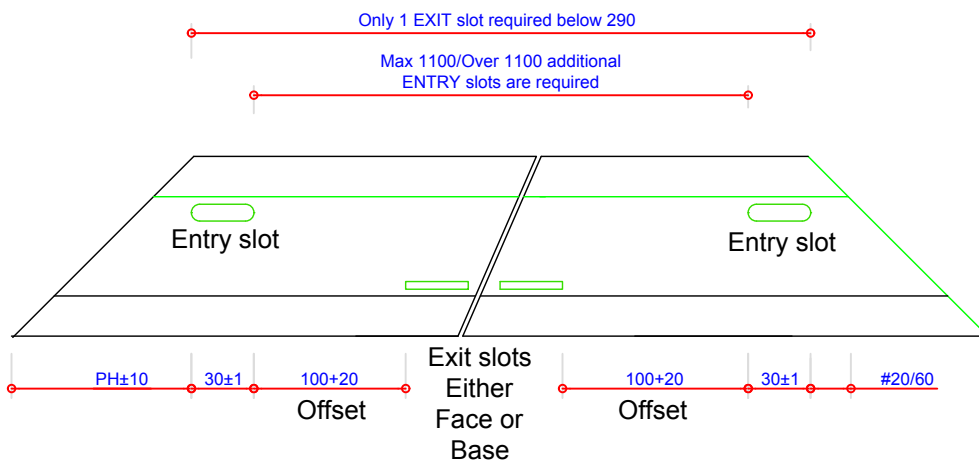

Drainage Routes

When running up or down vertically into a web ensure the cutter penetrates the web by 5mm.

55mm Outer Frame 101308

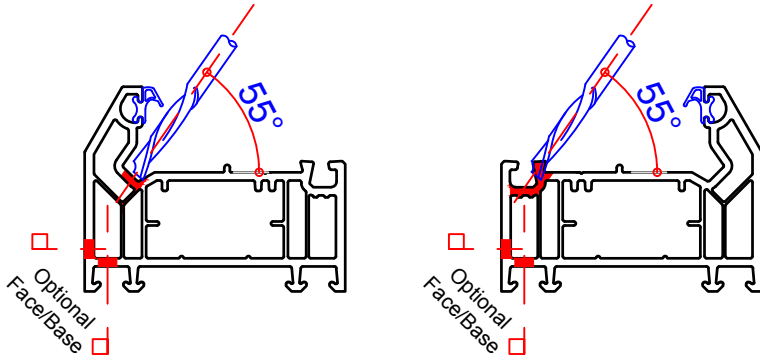

68mm T Mullion 102297

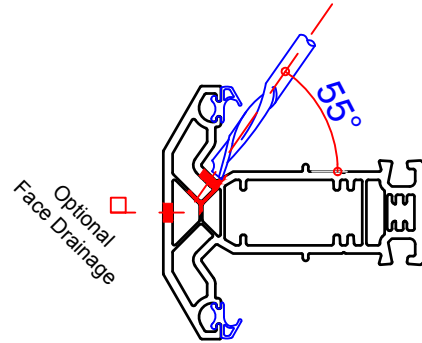

3

67mm Outer Frame 101309

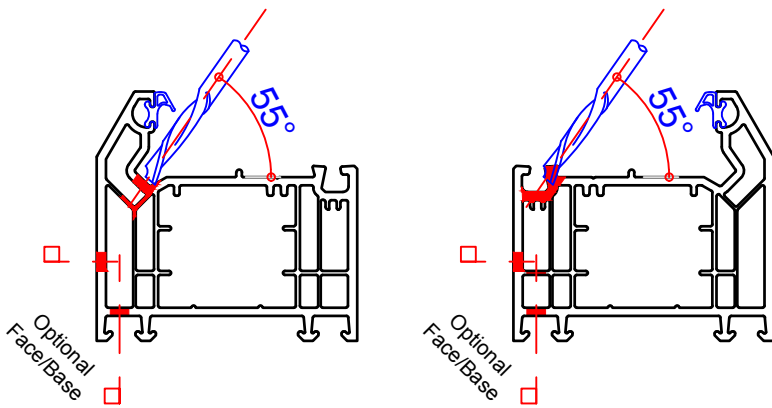

68mm Z Mullion 102298

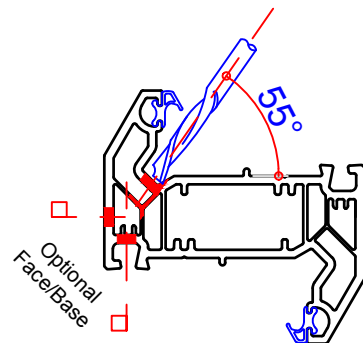

80mm Outer Frame 105176

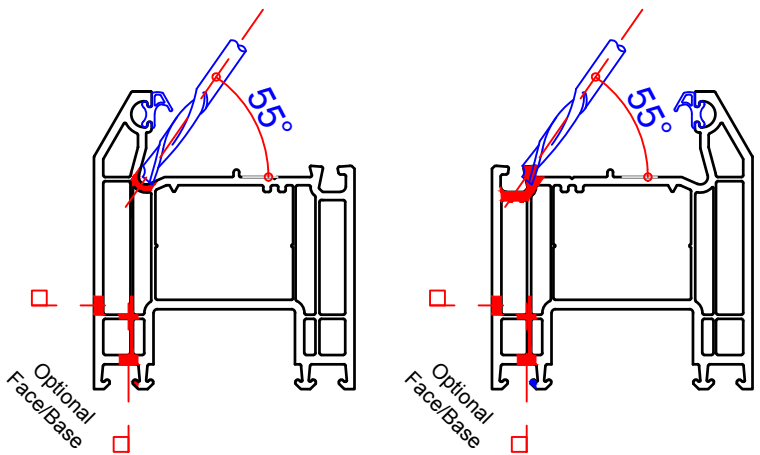

82mm T Mullion 102299

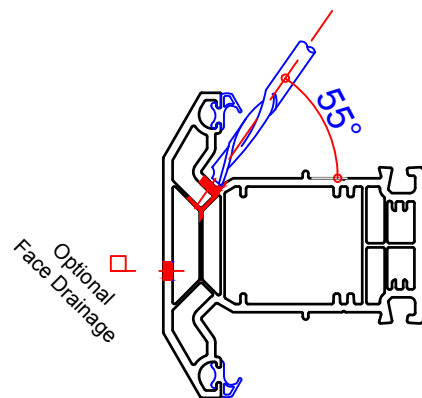

3

68mm T Mullion 102297

76mm Casement Sash/T Mullion 103365

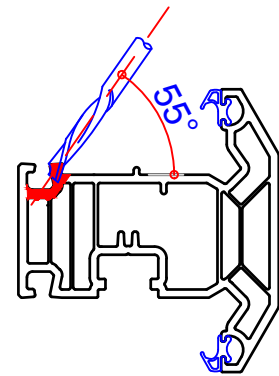
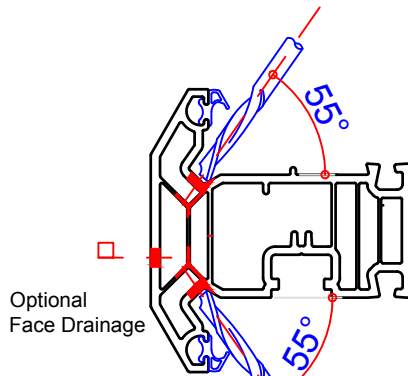
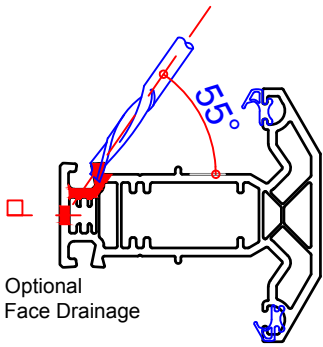

68mm Z Mullion 102298

82mm Tilt N Turn Sash/Z Mullion 103364

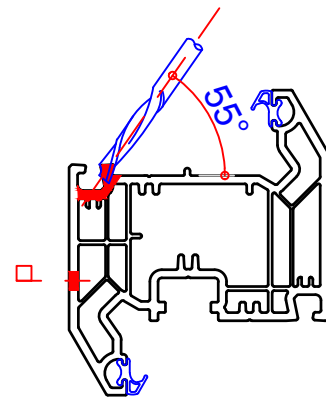
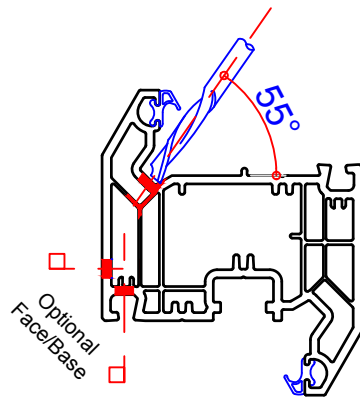
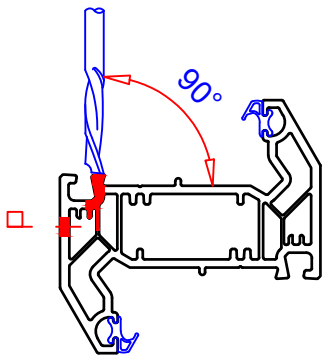

115mm Open In Door Sash/Z Midrail 103366

82mm T Mullion 102299

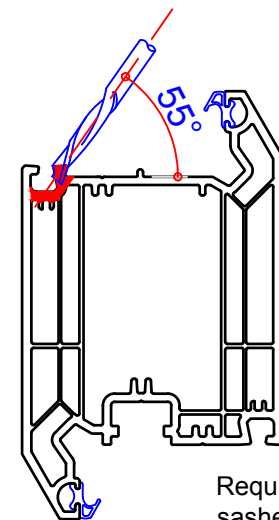
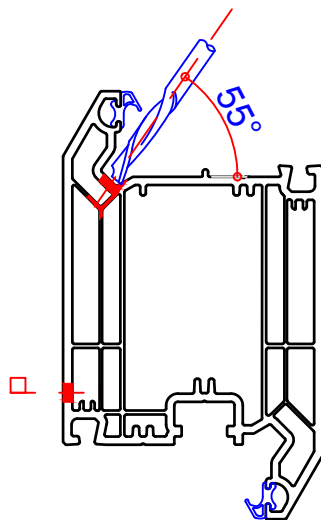
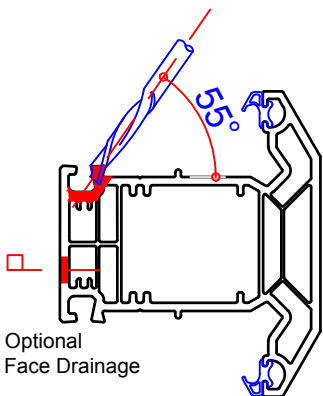

Required for sashes not for midrails.

115mm Open Out Door Sash/T Midrail 103367

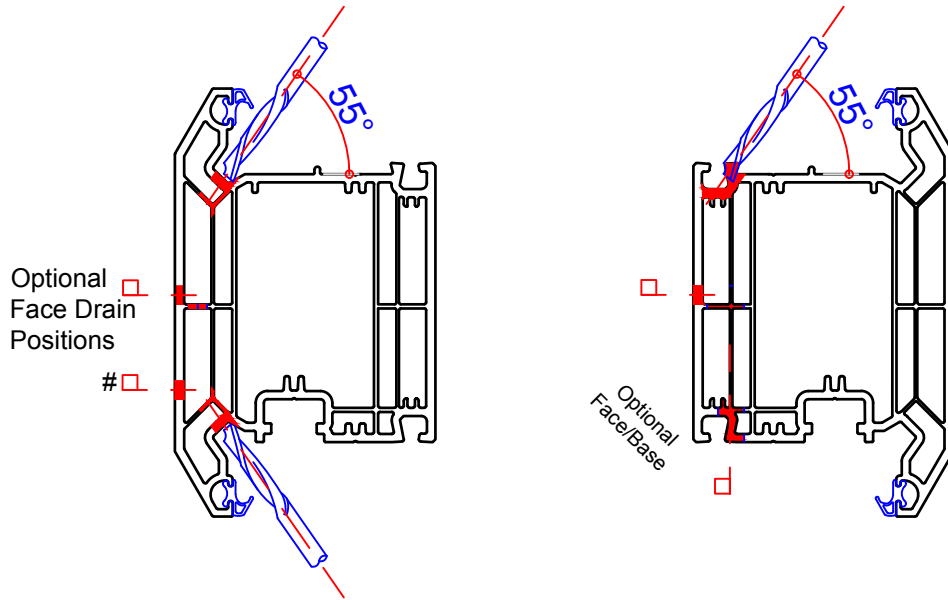

3

When using the lower face drain option the 115mm Open Out Door Sash/T Midrail 103367 centre web will need to be slotted prior to welding.

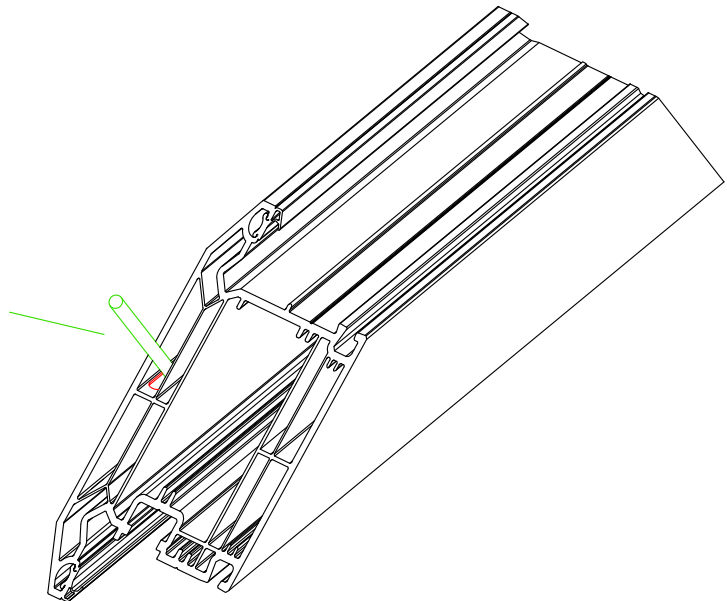

Mechanical Joint Dimensions

DXF/CAD files are available for all profiles through Technical Services or by contacting the VEKA Technical Department. Please quote the relevant part number.

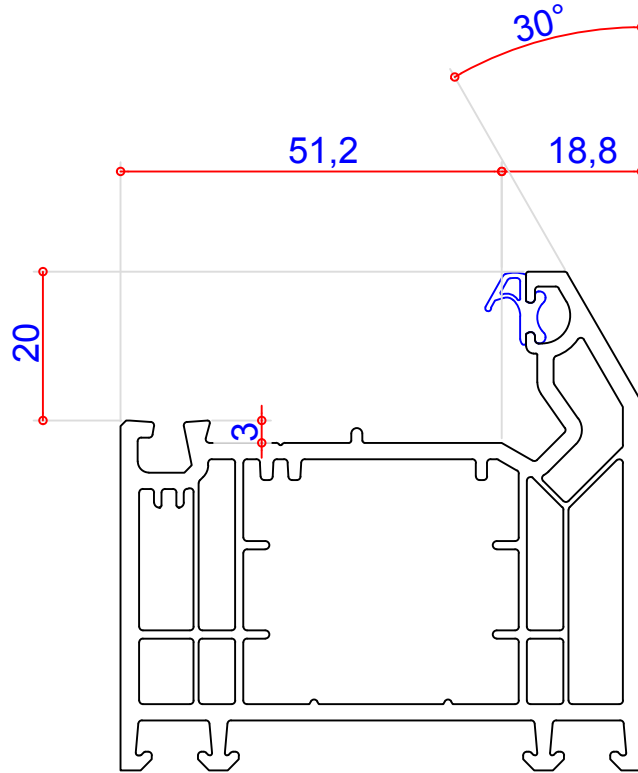

3

Scribed Beads & Georgian Bar Dimensions

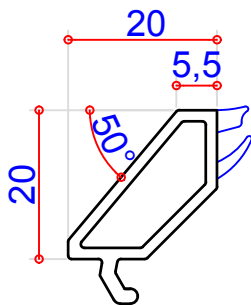

28mm Chamfered Glazing Bead 107154
Scribed bead rebate deduction = 11mm

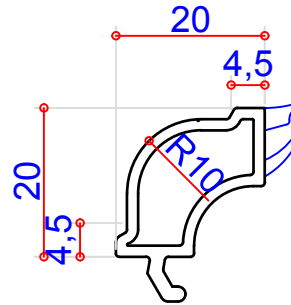

28mm Feature Glazing Bead 107153
Scribed bead rebate deduction = 9mm

Reinforcing

Optional reinforcing positions for 113410 Steel U Channel offer additional benefits to manufacturing & performance.

Standard position for 101308 55mm outer frames where reinforcing is required. Continuous reinforcing is achievable on jambs V cut to accept 102297 & 102298 68mm transoms.

Standard position for 101309 67mm outer frames where reinforcing is required. Continuous reinforcing is achievable on jambs V cut to all transoms apart from 103366 & 103367 115mm Midrails.

3



Optional secondary position for outer frames where reinforcing is required. Optimum screw retention for hardware.



Prepped Steel for 35mm Back set door locks
113414.500000

Steel Box 113424

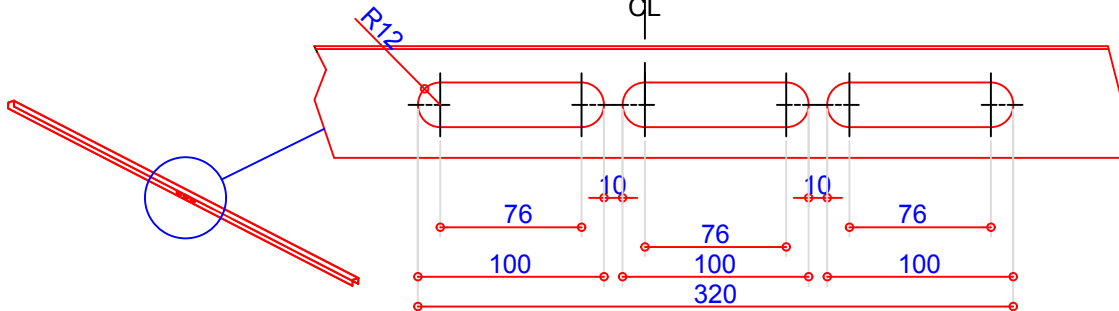
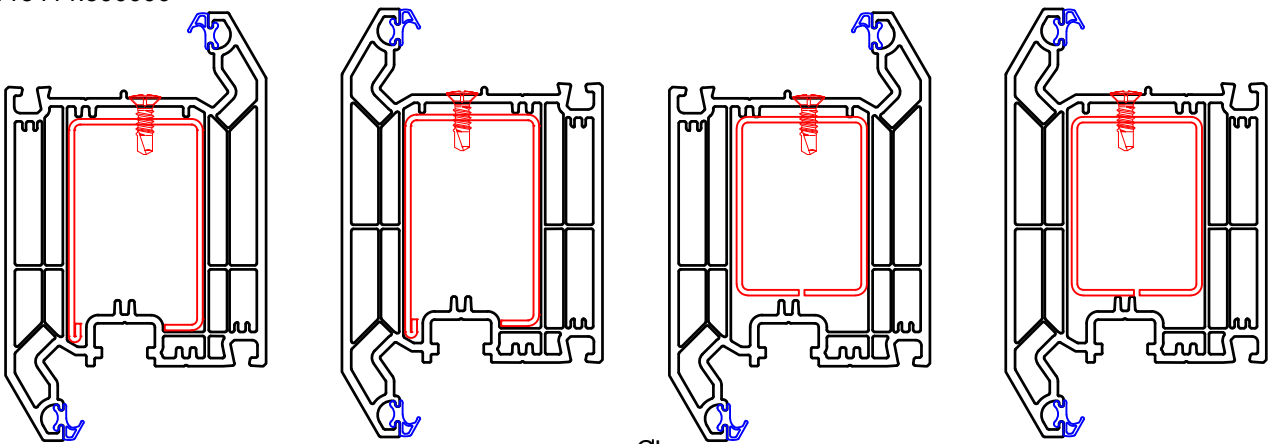

Hook lock reinforcing for door outer frames and mullions.

Reinforcing for sashes and mullions.

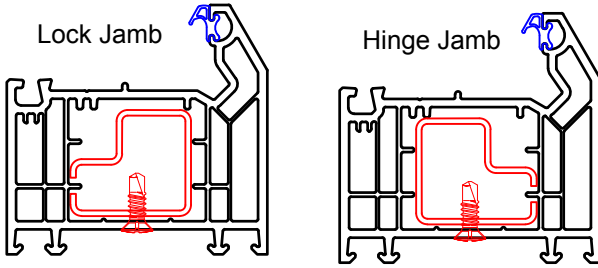

67mm Outer Frame 101309
Hook Lock Steel Box 113418

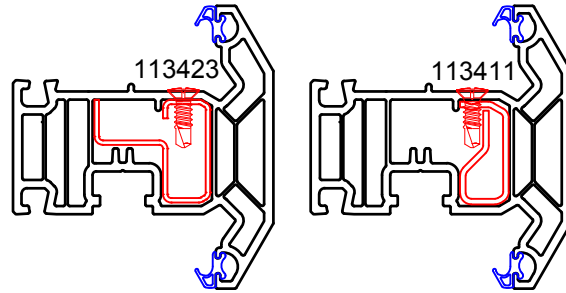

76mm Casement Sash/T Mullion 103365
Steel P Sections 113423 & 113411

3

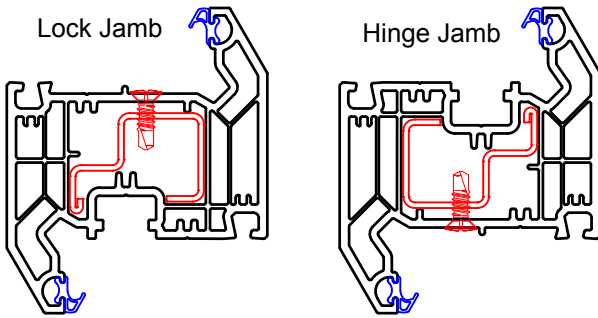

82mm Tilt N Turn Sash/Z Mullion 103364
*Hook Lock Steel U Channel 113417

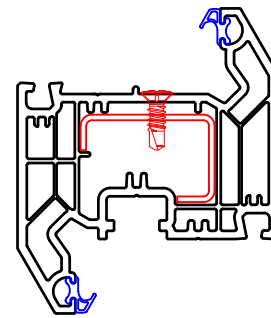

82mm Tilt & Turn Sash/Z Mullion 103364
*Steel U Channel 113413

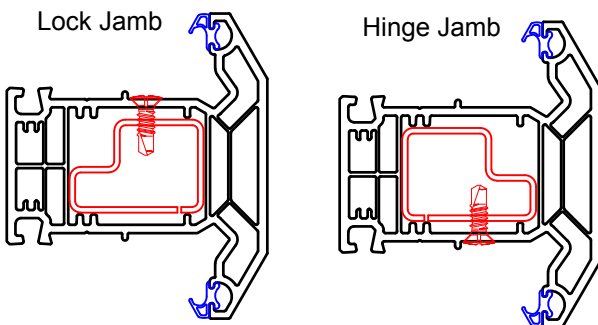

82mm T Mullion 102299
*Hook Lock Steel Box 113416

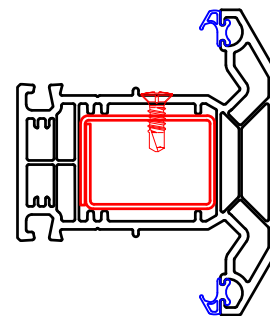

82mm T Mullion 102299
*Steel Box 113415



Screw size 3.9mm x 16mm drill point. Finish: yellow chromated, bright zinc plated or stainless steel.

Ported aluminium for mechanically jointed transoms and mullions.

68mm T Mullion 102297

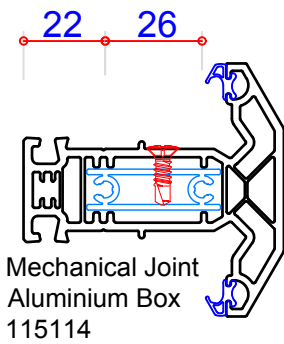

82mm T Mullion 102299

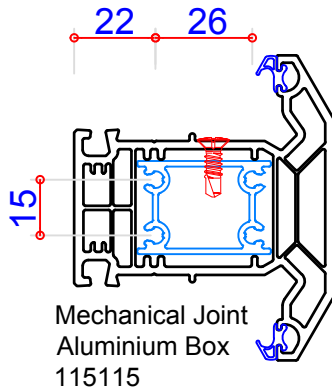

115mm T Midrail 103367

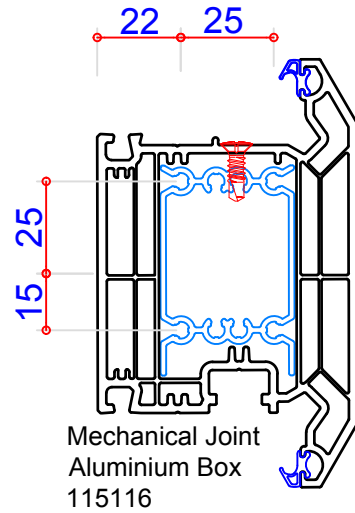

3

Mechanical Joints Mixed Reinforcement

In certain circumstances the ported aluminium reinforcement may not achieve the necessary strength and steel reinforcement would be required.

Mechanically coupling is possible by inserting the correct steel section between two 100mm long pieces of ported aluminium.

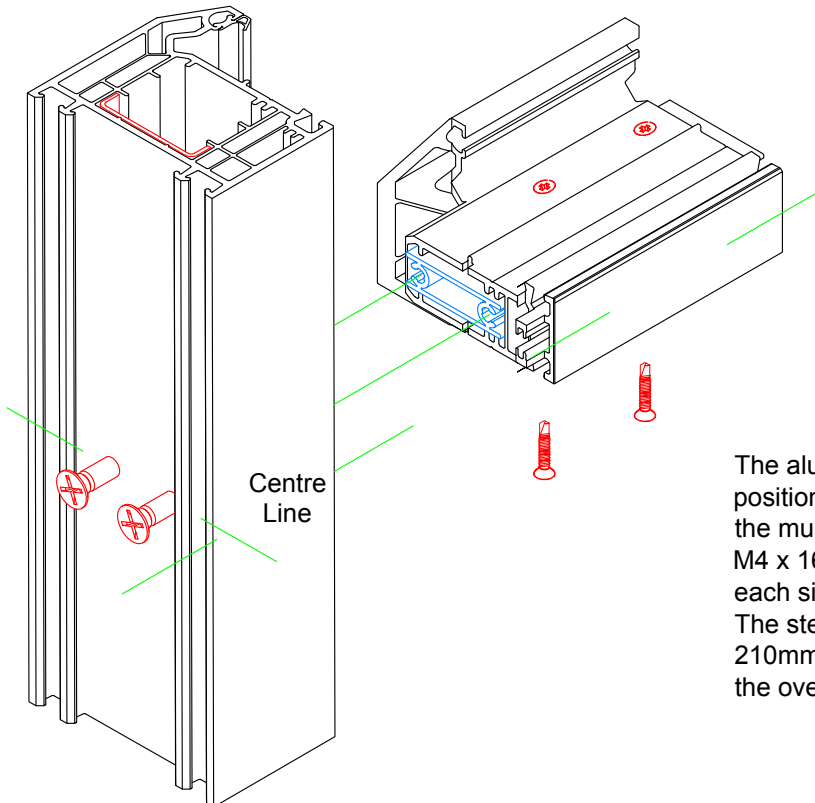

The aluminium section should be positioned 2mm back from the end of the mullion and secured in position with M4 x 16mm screws - two screws at each side of the section.

The steel reinforcement should be cut 210mm shorter than the overall length of the mullion.

Mechanical Joints: Cruciform Construction

The following procedure assumes that the mullions and transom are reinforced with steel and short aluminium blocks for coupling to the frame.

When the reinforcement cut-out in the profile has been prepared, the section can be reinforced. The steel section for this profile has to stop short at either side of the cut out to allow the other steel section to pass through the profile.

Fit and secure the short lengths of steel within the profile with the cut-out and also fit a 100mm block to both ends.

Fit and secure one 100mm aluminium block to the outer ends of the remaining short profiles.

Mill all the ends of the profiles as normal. The ends of the short sections where they abut the continuous profile will not have any reinforcement fitted, so ensure that the sections do not distort when machining is taking place.

Slide the continuous steel reinforcement through the slot in the continuous profile bar. Slide onto the steel reinforcement the shorter prepared profiles, one at either side.

Apply silicone sealant to the ends at the centre before proceeding any further.

Fit the cruciform grid into the frame, sealing the milled ends prior to final positioning.

With the use of a window frame clamp, pull the centre joints tight and secure the profile to the steel reinforcement, finally securing the end joints to the frame in the normal manner.

Note! When fitting the reinforcement and the aluminium blocks, ensure that there is a gap between each section of 3mm.

End mill the transom and mullions at points marked 'A'.
Where the steel is in 2 pieces, leave a 3mm gap at centre to clear the continuous steel

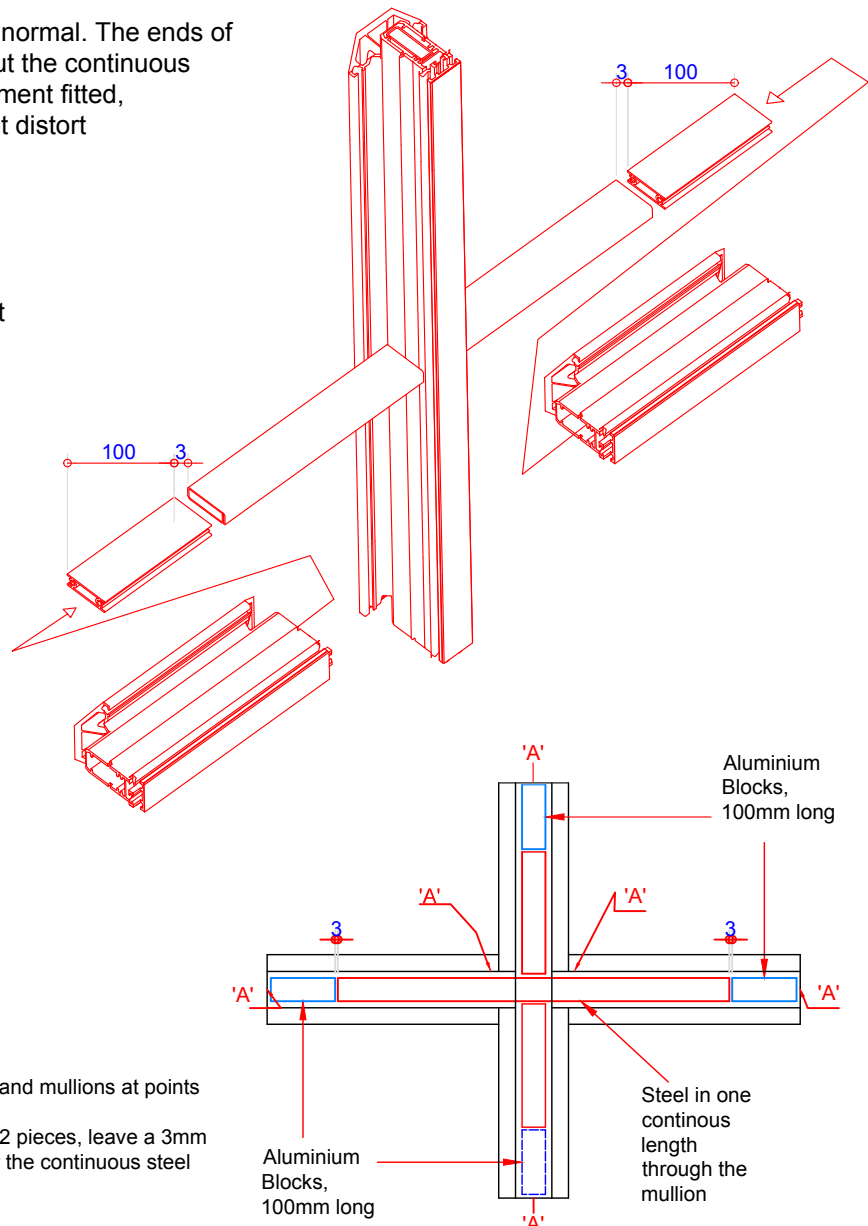

3

Low Threshold Preparation

Standard Low Threshold 704092
Standard Threshold Gasket 712005

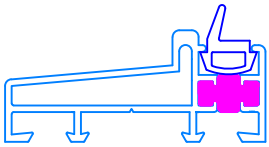

712005 Gasket cut length = 101309
Outer frame width - 88mm + (5-10mm)
to ensure good compression.

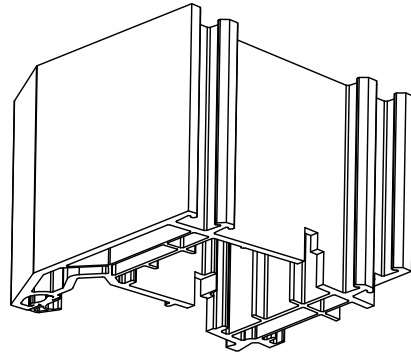

3

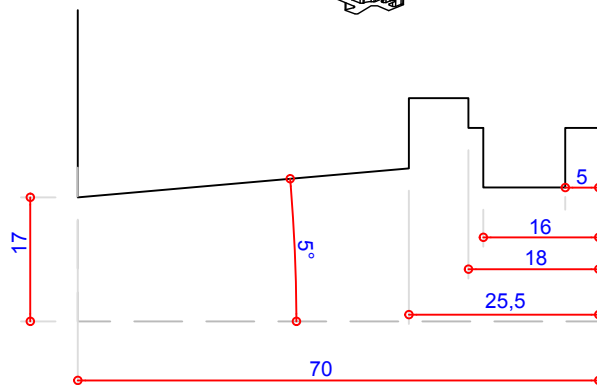

Part M Low THreshold 704289
Threshold Seal 712086
Sash Seal 712087
Threshold Strip 709047
Threshold Adapter 709225

709047 Gasket cut length
= Sash width - 30mm.

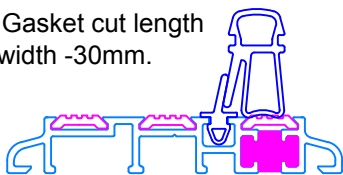

712086 Gasket cut length = 101309
Outer frame width - 88mm + (5-10mm).

709047 Threshold Strip to be trimmed to
sit inside outer frame then sealed using
a good quality sealant.

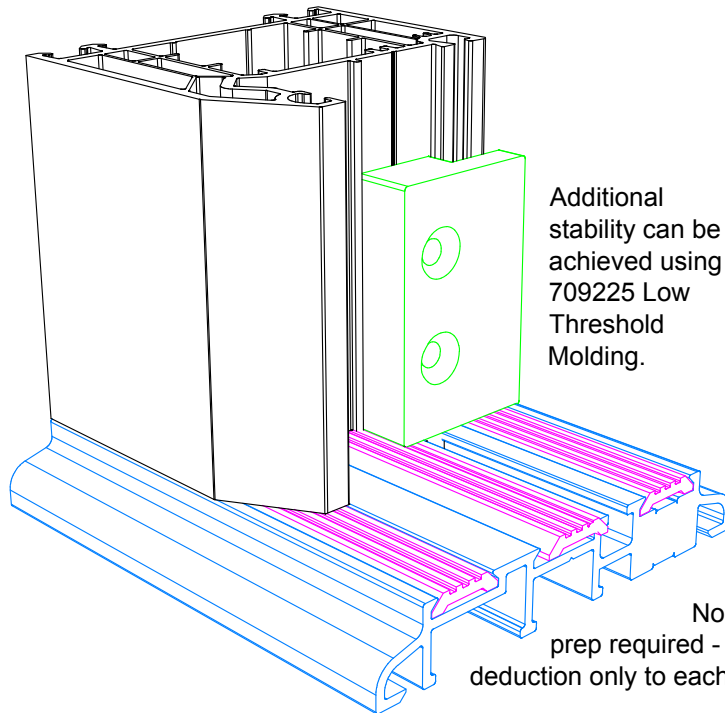

Additional
stability can be
achieved using
709225 Low
Threshold
Molding.

No milled
prep required - 15mm
deduction only to each jamb.

Low Threshold Fixing Positions

Using ported aluminium 115115

4 Possible/Optional fixing positions - minimum 2 fixings required to reduce twist.

Seal all mating faces.

Secure with 4.8mm x 50mm pan head screws.

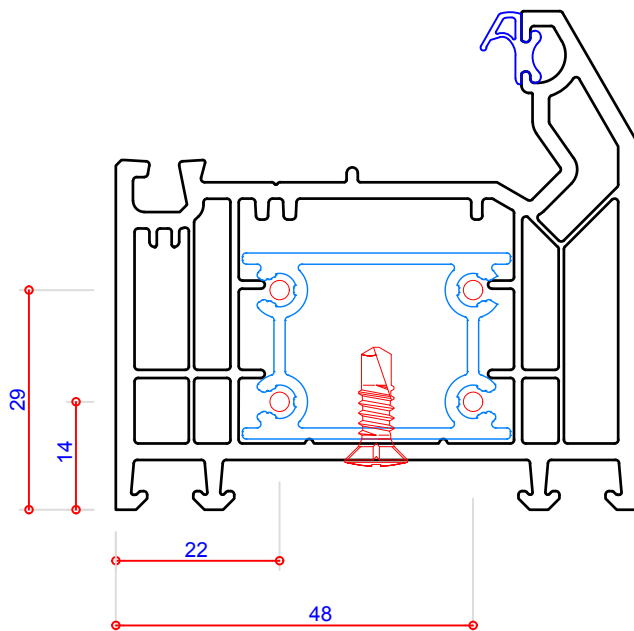

Fixing detail also applies to 704289 Threshold.

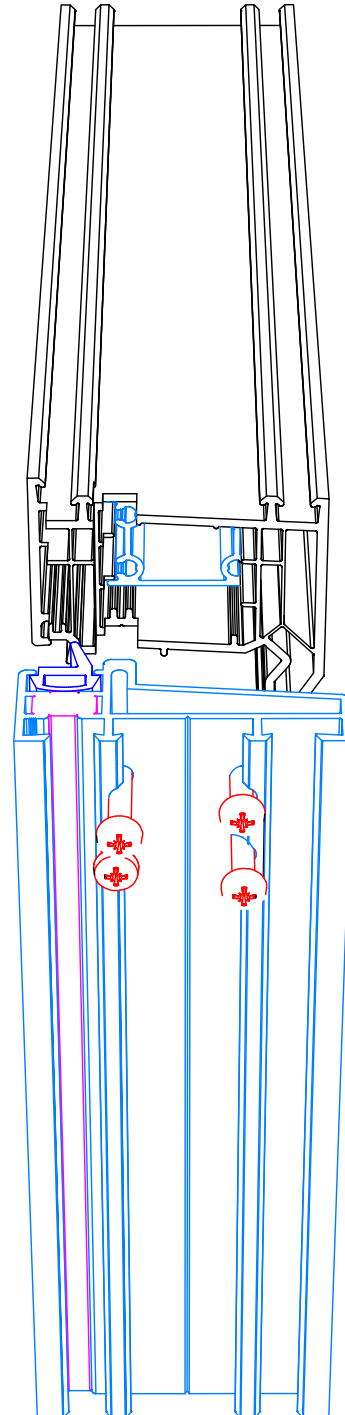

3

Screw Specification

Espagnolette

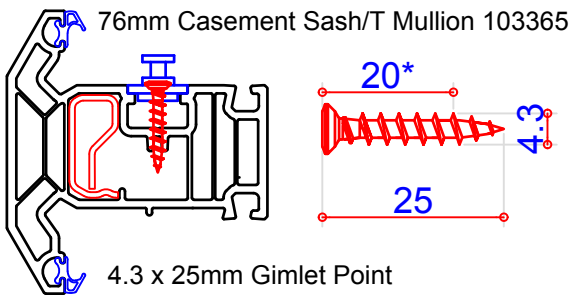

*Effective thread length

Note: In order to prevent bi-metallic corrosion VEKA plc. recommends that all stainless steel friction stays should be attached to the frame and sash with suitable stainless steel screws

3

Friction Stays

Reinforced Outer Frame

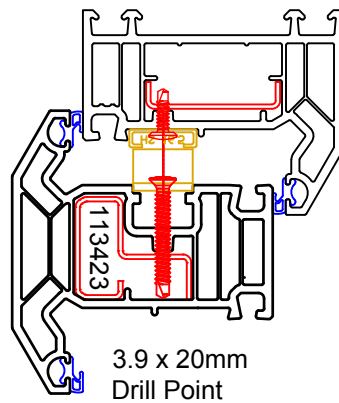
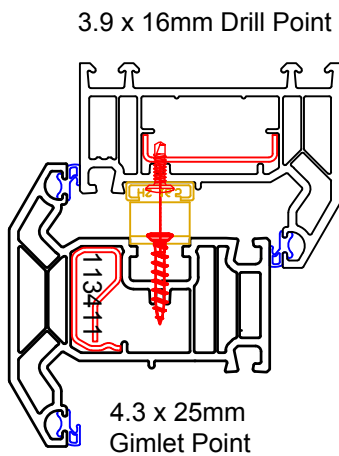

Un-reinforced Outer Frame



Rider Blocks

Reinforced Outer Frame

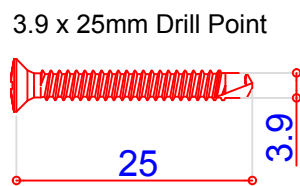
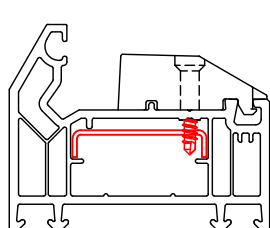

4.3 x 25mm Gimlet Point

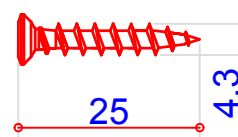

Un-reinforced Outer Frame

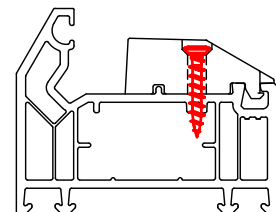

Screw Specification

French Mullion - Doors

Step 1

The first two screws to be positioned top and bottom, 50mm from either end (+/- 20mm) then equally spaced approximately 200mm centres the full length of the mullion.

3.9 x 16mm Drill Point

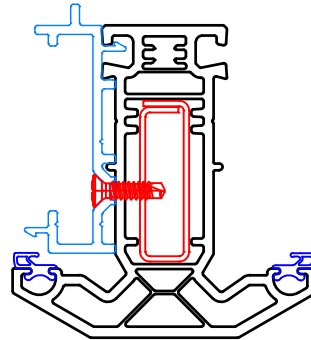

3

Step 2

Pre drill and countersink prior to fixing. The first two screws to be positioned top and bottom, 100mm from either end (+/- 20mm) then equally spaced maximum 300mm centres. The top screws may not pick up reinforcing on tall slave doors where pre routed steel has been fitted.

6.0mm x Self Tapping Screw Length 55mm - 65mm for casements or 60mm - 70mm for doors.

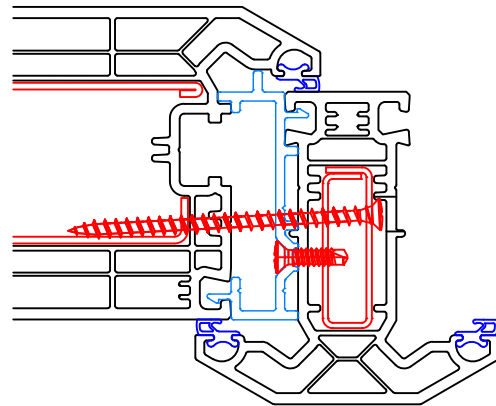
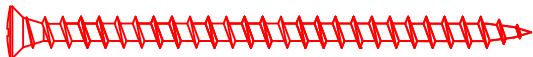

Step 3

Attach the 109057 end cap to the 102297 mullion using a 6mm self tapping screw. Seal all mating faces with a good quality silicone for improved weather performance.

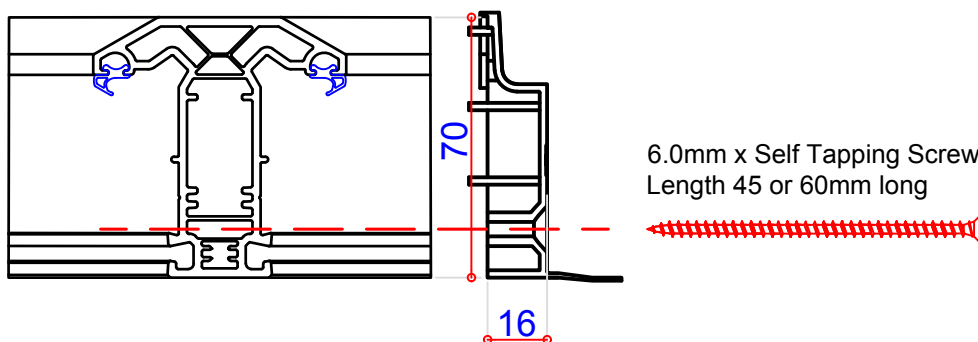

Hardware Specification

Casement

Sash Cover	8 Both sides
Back Set	22
Stack Height	17
Spindle length	35
Mushroom/Cam	9

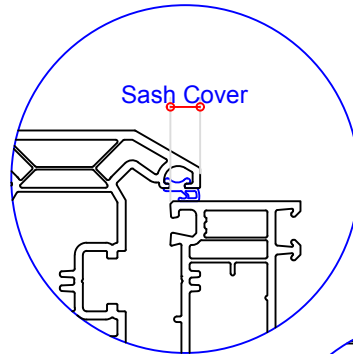

3

Tilt & Turn

Sash Cover	8 Both Sides
Back Set	14/15
Hinge Height	19
Mushroom/Cam	8
Spindle length	40

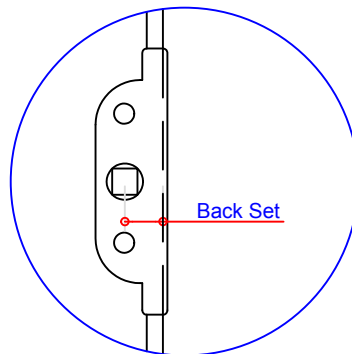
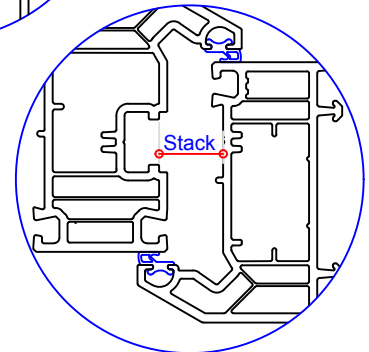

Door

Sash Cover	8
Back Set	35
Hinge Height	19
Cylinder size	40/50 or 35/10/45

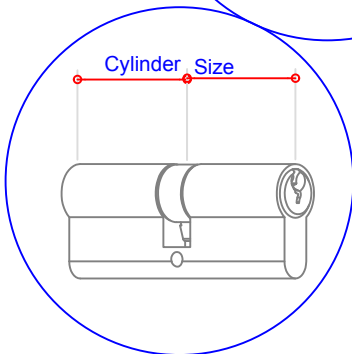
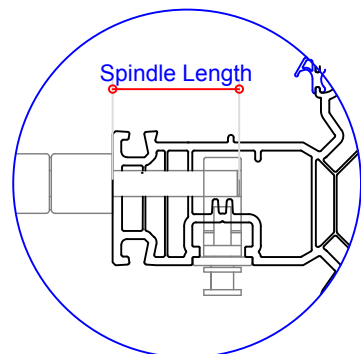
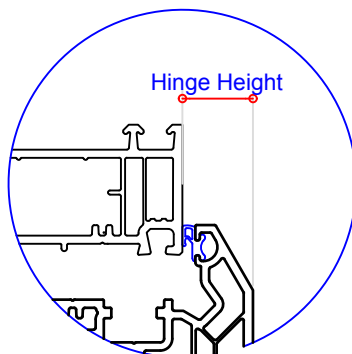
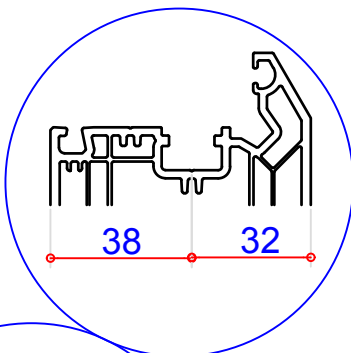
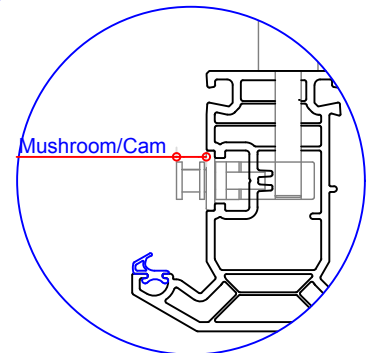

ACCREDITATIONS

COMPONENTS

1

DESIGNS AND STATISTICS

2

MANUFACTURE

3

ACCREDITATIONS

4

REVISIONS

5

4.00.1	This page
4.01.1	Thermal Performance - Windows
4.02.1	Thermal Performance - Doors
4.03.1	Kitemark Schedule - Windows
4.04.1	Kitemark Schedule - Doors
4.05.1	Kitemark Approved Hardware - Top Hung Casement
4.06.1	Kitemark Approved Hardware - Side Hung Casement
4.07.1	Kitemark Approved Hardware - Tilt And Turn
4.08.1	Kitemark Approved Hardware - Single Door & French Door
4.09.1	Kitemark Additional Hardware Positions
4.10.1	Kitemark - Profiles
4.11.1	Kitemark - Profiles Continued

Typical U-Values & Energy Rating Examples

Casement Window

Using a warm edge spacer and argon gas filled cavity.

Frame	Mullion	Sash	Reinforcing	Outer Pane	Inner Pane	Glazing	Rating	Index	U-value
55	68	76	Full	Clear	0.05	28mm	A	5	1.4
55	68	76	Domestic	Clear	0.05	28mm	A	7	1.3
55	68	76	Full	Low Iron	0.05	28mm	A	9	1.4
55	68	76	Domestic	Low Iron	0.05	28mm	A+	11	1.3
55	68	76	Full	Clear	2x 0.05	44mm	A+	19	0.93
55	68	76	Domestic	Clear	2x 0.05	44mm	A++	21	0.90
55	68	76	Full	Low Iron	2x 0.05	44mm	A++	24	0.93
55	68	76	Domestic	Low Iron	2x 0.05	44mm	A++	26	0.90
67	68	76	Full	Clear	0.05	28mm	A	1	1.4
67	68	76	Domestic	Clear	0.05	28mm	A	2	1.4
67	68	76	Full	Low Iron	0.05	28mm	A	5	1.4
67	68	76	Domestic	Low Iron	0.05	28mm	A	7	1.3

4

Tilt And Turn Window

Using a warm edge spacer and argon gas filled cavity.

Frame	Mullion	Sash	Reinforcing	Outer Pane	Inner Pane	Glazing	Rating	Index	U-value
55	68	82	Full	Clear	0.05	28mm	A	1	1.4
55	68	82	Domestic	Clear	0.05	28mm	A	4	1.4
55	68	82	Full	Low Iron	0.05	28mm	A	5	1.4
55	68	82	Domestic	Low Iron	0.05	28mm	A	8	1.4
67	68	82	Full	Clear	0.055	28mm	B	-3	1.4
67	68	82	Domestic	Clear	0.05	28mm	A	0	1.3
67	68	82	Full	Low Iron	0.05	28mm	A	1	1.4
67	68	82	Domestic	Low Iron	0.05	28mm	A	4	1.3

Residential Door

Using a warm edge spacer and argon gas filled cavity.

Frame	Mullion	Sash	Threshold	Reinforcing	Outer Pane	Inner Pane	Glazing	Rating	Index	U-value
67	115	115	67	Full	Clear	0.05	28mm	C	-94	1.4
67	115	115	15	Full	Clear	0.05	28mm	C	-96	1.4
80	115	115	80	Full	Clear	0.05	28mm	C	-94	1.4
80	115	115	15	Full	Clear	0.05	28mm	C	-96	1.4

4

French Door

Using a warm edge spacer and argon gas filled cavity.

Frame	Mullion	Sash	Threshold	Reinforcing	Outer Pane	Inner Pane	Glazing	Rating	Index	U-value
67	115	115	67	Full	Clear	0.05	28mm	B	-6	1.4
67	115	115	26	Full	Clear	0.05	28mm	B	-9	1.4
67	115	115	67	Full	Low Iron	0.05	28mm	B	-2	1.4
67	115	115	26	Full	Low Iron	0.05	28mm	B	-3	1.4
80	115	115	80	Full	Clear	0.05	28mm	B	-9	1.4
80	115	115	26	Full	Clear	0.05	28mm	C	-12	1.4

Kitemark Schedule PAS 24 Licence No. KM 33520 - Windows

BS 12608:2003/PAS 24:2012 - General and enhanced security performance requirements for window assemblies.

Fabricated and installed in accordance with the latest issue(s) of the VEKA Group -M70 technical manual.

The windows are double glazed, internally beaded, multipoint locking, with welded transoms/mullions, tee joints and are classified WK or WKT.

Size Limitations and Performance Characteristics

4

Window Type	Length (mm) - Maximum	Height (mm) - Maximum	Area (m ²) - Maximum	Friction Stays (up to and including)	Transom/Mullion Length (mm) inc frame - Maximum	Air Permeability classification	Watertightness Classification	Resistance to Wind classification	Exposure category as given in Table 1 of BS 6375-1:2009
Sash dimensions for windows with approved sash profiles:									
Projected top hungs Reinforced	1454	1454	-	24"	-	4	8A	AE2400	2000+
Projected side hungs Reinforced	800	1554	-	16"	-	4	9A	AE2400	2000+
Tilt/turns Reinforced	1678	1678	-	-	-	3	9A	AE2400	2000+
Overall dimensions for windows with approved outer frame profiles:									
Fixed Reinforced	3000	3000	9	-	-	4	9A	AE2400	2000+
Overall dimensions for approved outer frames & transom/mullion profiles:									
Casements Multilights 113415 T/M Reinforced	2266	1454	3.29	-	1454	4	8A	A5	2000
Casements Multilights 113412 T/M reinforcement	2266	1454	3.29	-	1360	4	8A	A5	2000
Tilt/Turn Multilights 113415 T/M reinforcement	2500	1678	4.20	-	1678	4	8A	A5	2000

Kitemark Schedule PAS 24 Licence No. KM 60983 - Doors

BS 12608:2003/PAS 24:2012 - General and enhanced security performance requirements for door assemblies.

Fabricated and installed in accordance with the latest issue(s) of the VEKA Group -M70 technical manual.

This Licence covers the following residential door system design specification. Only those components that have been approved in accordance with the Kitemark scheme requirements can be incorporated within the system(s) detailed.

4

The door assemblies are single or double leaf, open in or out with compliant IGU(s), laminated on one pane; or panelled infill(s), with or without midrail with either an approved aluminium low threshold or standard PVC threshold. Doors are classified as DK.

Size Limitations and Performance Characteristics

Door Sash Type	Length (mm) - Maximum	Height (mm) - Maximum (Including sill)	Air Permeability Classification	Watertightness Classification	Resistance to Wind Classification	Exposure category as given in Table 1 of BS 6375-1:2009
Sash dimensions for doors with approved outer frame and sash profiles:						
Single Leaf	1125	2125	4	7A	A3	1200
Double Leaf	2340	2190	3	7A	A3	1200
Double Leaf (COBRA Lock)	2340	2190	2	E750	A3	1200

Kitemark 33520 Pas 24 Approved Hardware.



















Individual Fixed Window

Maximum Width = 3000mm Maximum Height = 3000mm

All the hardware listed can be used in any combination and are considered to meet the requirements of the Kitemark Scheme.

Top Hung Casement Sash



















Maximum Width = 1454mm Maximum Height = 1454mm

Hardware Type	Supplier	Type	Test Report Number	
Hinge	 Cotswold	Sinidex	BSI 8292997 / 8293007	
	 Cotswold	EZ		
	 Nico	Standard/Heavy Duty	BSI 8293013	
	 Securistyle	Defender	STR257ES	
	 DGS	Elite		
Lock	 Nico	Multilock	BSI 8293013	
	 Maco	M-Spag (Croppable With Extensions and centre locks)	BSI 8292997	
	 Maco	M-Spag Telescopic		
	 Maco	Rail		
	 Yale	Blade	BSI 8293007 / STR257ES	
	Additional Security	 Maco	Hinge Protector	BSI 8292997 / 8293009
		 GT	Securi-Clips (Glazing)	BSI 8293007 / 8293009 / 8293013
		 GT	Stayguard Elite (Hinge Protectors)	
 Nico		Xtra Bolt (Hinge Protectors)	BSI 8293013	
 Securistyle		Vector Excluder ASD2		
Handle	 VEKA	Run Up Blocks 109056	BSI 8292997 / 8293007 / 8293009 / 8293013	
	 Glazepart	Cavity Closing Wedge	BSI 8292997 / 8293007	
	 FAB N FIX	Connoisseur	BSI 8293009	

Kitemark 33520 Pas 24 Approved Hardware.









Side Hung Casement Sash

Maximum Width = 800mm Maximum Height = 1554mm

Hardware Type	Supplier	Type	Test Report Number
Hinge	 Cotswold	Sinidex	BSI 8292997 / 8293009 / 8269986
	 Cotswold	EZ	
	 Nico	Standard/Heavy Duty	BSI 8293013
	 Securistyle	Securistyle	Defender
Lock	 DGS	Elite	
	 Maco	M-Spag (Telescopic Shootbolt)	BSI 8293009
	 Maco	M-Spag Telescopic	
	 Maco	Rail	
	 Nico	Multilock	BSI 8293013
	 Yale	Blade	BSI 8293007 / STR257ES
	 Maco	Hinge Protector	BSI 8293009 / 8293009
	 Securistyle	Securistyle	Vector Excluder ASD2
Additional Security	 GT	Securi-Clips (Glazing)	BSI 8293007 / 8293009
	 GT	Stayguard Elite (Hinge Protectors)	BSI 8269986
	 Nico	Xtra Bolt (Hinge Protectors)	BSI 8293013
	 VEKA	Run Up Blocks 109056	BSI 8292997 / 8293007 / 8293009 / 8293013
	 Glazepart	Cavity Closing Wedge	BSI 8292997 / 8293007
Handle	 Fab N Fix	Connoisseur	BSI 8293009









4

Tilt & Turn Sash**Maximum Width = 1678mm Maximum Height = 1678mm**

Hardware Type	Supplier	Type	Test Report Number
Hinge/Lock	 Maco	Multi Matic Face Mounted	BSI 8292997 / 8293009
	 Siegenia	Favorit Face Fixed	BSI 8293007
	 Siegenia	Favorit axxent concealed	
Additional Security	 Roto	Royale NT	
	 GT	Securi-Clips (Glazing)	BSI 8293007 / 8293009
	 VEKA	Run Up Blocks 109398	BSI 8293009
	 Siegenia	Favorit Anti Lift Block	BSI 8293007
Handle	 Roto	Sekustick	BSI 8292997/8293007

4

Kitemark 60983 Pas 24 Approved Hardware.**Residential & French Doors****Maximum Sash Width = 1122mm Maximum Height = 2122mm**

















Hardware Type	Supplier	Type	Test Report Number
Handle	 Fab N Fix	Balmoral	BSI 8293026
	 Fab N Fix	Berwick	
	 Yale	Platinum Y2G HSLL 2*	
	 Winkhaus	Hoppe 425 Series 56/70	
	 Trojan	Sparta 0749 Security 2*	
Additional Security	 VEKA	Run Up Blocks 109398	BSI 8293023 / 8293025 / 8293026 / 8293029
	 GT	Securi-Clips (Glazing)	BSI 8293023 / 8293026 / 8293029
	 GT	Guardian Hinge Protector	
	 Winkhaus	ArmorShield Cylinder Guard	

Kitemark 60983 Pas 24 Approved Hardware.

Residential & French Doors

Maximum Sash Width = 1122mm

Maximum Height = 2122mm

Hardware Type	Supplier	Type	Test Report Number	
Lock	 Maco	C-TS Top Hat	BSI 8293023	
	 Millenco	Mantis	BSI 8293026	
	 Fullex	XL Door Lock	BSI 8293029	
	 Winkhaus	Cobra		
Cylinder	 ERA	ERA	DL-863500-85AA	
	 Fullex	Fullex	Kinetica 40/50 3*	BSI 829302
	 Maco	Maco	Guardian 40/50 3*	
	 Yale	Yale	Platinum 40/50 3*	
	 Yale	Yale	PKM3545 35/45 1*	
	 Brisant	Brisant	Secure 40/50 3*	
	 Winkhaus	Winkhaus	XR6-51 38/48 1*	
	 ERA	ERA	Fortress TS007 3*	
	 Titon	Titon	Asterion TS007 3*	
	Hinges	 SFS	SFS	Dynamic 2D
 ERA		ERA	Anchorage HD Flag	
Part M Low Threshold	 Stormguard	Stormguard	Proline	BSI 8293025
	 VEKA	VEKA	TH-One	

4

Kitemark Approved Hardware.

Additional Hardware Positions

- ① Run Up Block
- ② Cavity Wedge
- ③ Anti Lift Block

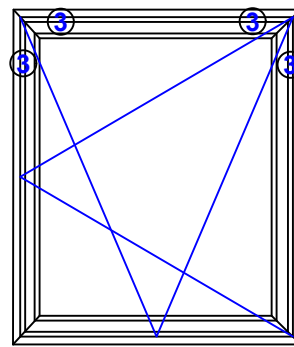
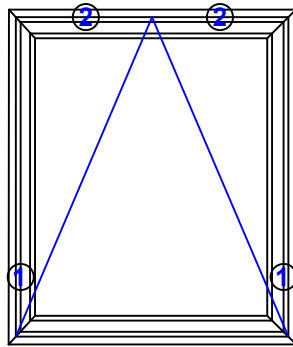
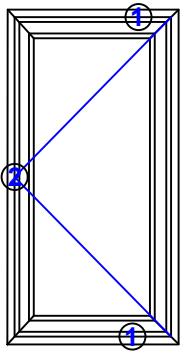

4

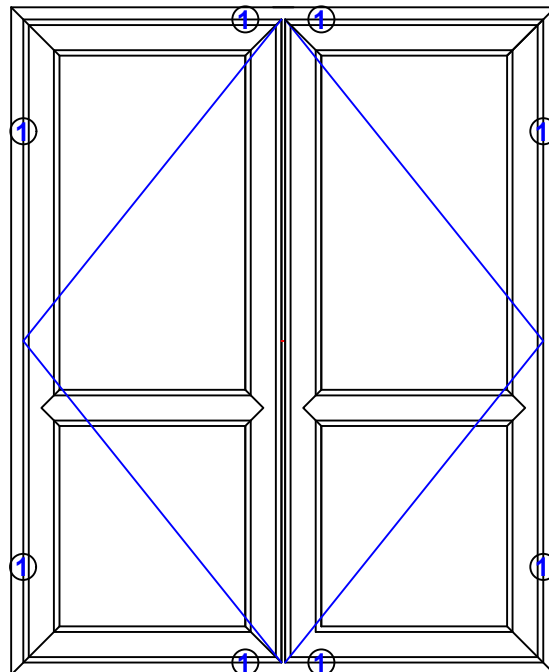
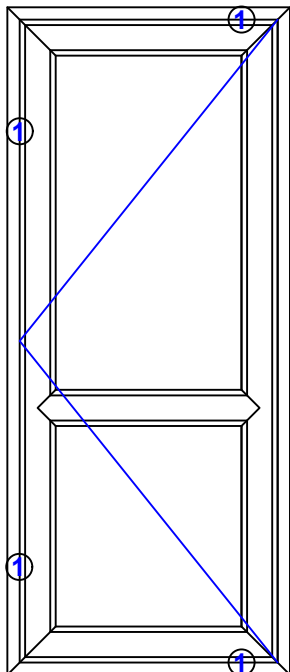

Kitemark 12875.

BS EN 12608 PVC-U Profiles for the fabrication of windows and doors

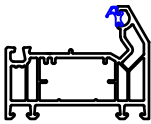
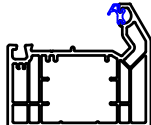
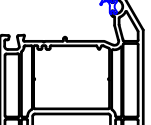
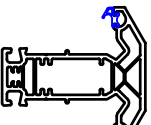
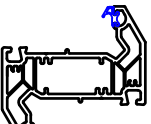
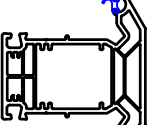
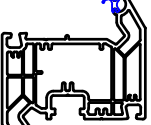
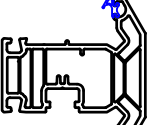
Symbol	Code	Description	Reinforcement Code
	101308	55mm Outer Frame	Steel 113410 Steel 113421
	101309	67mm Outer Frame	Steel 113410 Steel 113418 Steel 113422
	105176	80mm Outer Frame	Steel 713191 Steel 113418 Alum 115115
	102297	68mm T Mullion	Steel 113412 Alum 115114
	102298	68mm Z Mullion	Steel 113412 Alum 115114
	102299	82mm T Mullion	Steel 113415 Steel 113416 Alum 115115
	103364	Tilt & Turn Sash/82mm Z Mullion	Steel 113413 Steel 113417
	103365	Casement Sash/76mm T Mullion	Steel 113411 Steel 113423

Kitemark 12875.

BS EN 12608 PVC-U Profiles for the fabrication of windows and doors

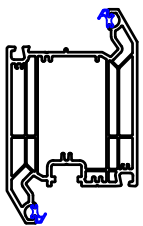
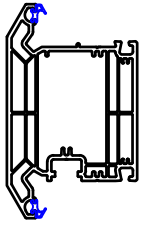
Symbol	Code	Description	Reinforcement Code
	103366	115mm Open In Door Sash/Z Midrail	Steel 113414 Steel 113414.5
	103367	115mm Open Out Door Sash/T Midrail	Steel 113414 Steel 113414.5

4

COMPONENTS

1

DESIGNS AND STATISTICS

2

MANUFACTURE

3

ACCREDITATIONS

4

REVISIONS

5

REVISIONS

- 5.00.1 This page
- 5.01.1 Amendments 1
- 5.02.1 Amendments 2
- 5.03.1 Amendments 3
- 5.04.1 Amendments 4

Amendments 1				
Page	Previous Issue	New Issue	Details	Initial
3.11.1	June 15	June 16	End mill details changed for 704092 Threshold	PG
1.03.1	June 15	June 16	Fixing nipple part number changed to alternative	PG
3.15.1	June 15	Oct 16	Spindle length for casement changed from 30 to 35mm	PG
1.03.1	June 15	Oct 16	112279 Gasket description changed from 4 to 3.5mm	PG
3.08.1	June 15	Oct 16	113423 Reinforcing fixing position added to 103365	PG
1.01.1	June 15	Oct 16	113421 & 113422 Reinforcing added	PG
1.02.1	June 15	Oct 16	113423 Reinforcing added	PG
3.14.1	June 15	Oct 16	Countersink instruction added	PG
3.14.1	June 15	Oct 16	Screw size added	PG
3.11.1	June 15	Oct 16	709225 assembly diagram added	PG
2.17.1	June 15	Oct 16	Welded & Mechanical mullion sizes corrected for 55mm outer to to suit 68mm False Mullion	PG
2.13.1	June 15	Oct 16	Additional labels added & sizes in red altered	PG
2.14.1	June 15	Oct 16	Additional labels added & sizes in red altered	PG
2.15.1	June 15	Oct 16	Additional labels added & sizes in red altered	PG
2.16.1	June 15	Oct 16	Additional labels added & sizes in red altered	PG
2.17.1	June 15	Oct 16	Additional labels added & sizes in red altered	PG
2.18.1	June 15	Oct 16	Additional labels added & sizes in red altered	PG
2.19.1	June 15	Oct 16	Additional labels added & sizes in red altered	PG
2.20.1	June 15	Oct 16	Additional labels added & sizes in red altered	PG
2.21.1	June 15	Oct 16	Additional labels added & sizes in red altered	PG
2.22.1	June 15	Oct 16	Additional labels added & sizes in red altered	PG
3.03.1	June 15	Oct 16	Drainage routing angles changed	PG
3.04.1	June 15	Oct 16	Drainage routing angles changed	PG

Amendments 2				
Page	Previous Issue	New Issue	Details	Initial
3.05.1	June 15	Oct 16	Drainage routing angles changed	PG
4.03.1	June 15	Oct 16	Size limitations and performance characteristics updated	PG
4.04.1	June 15	Oct 16	Size limitations and performance characteristics updated	PG
4.05.1	June 15	Oct 16	Size limitations and performance characteristics updated	PG
4.06.1	June 15	Oct 16	Size limitations and performance characteristics updated	PG
4.07.1	June 15	Oct 16	Size limitations and performance characteristics updated	PG
4.08.1	June 15	Oct 16	Size limitations and performance characteristics updated	PG
4.10.1	June 15	Oct 16	Additional reinforcing added	PG
2.11.1	June 15	Oct 16	Dimensions on diagram corrected to match tables	PG
2.12.1	June 15	Oct 16	Dimensions on diagram corrected to match tables	PG
1.02.2	June 15	Oct 16	New Page added for glazing options	PG
1.07.1	June 15	Oct 16	Minimum angles for variable post reduced to 120°	PG
1.02.1	Oct 16	Jan 17	113424 Steel box added	PG
3.07.1	Oct 16	Jan 17	113424 Steel box added	PG
3.07.1	Jan 17	Sep 17	Dimension changed on Dogbone Coupler	PG
3.01.1	Jan 17	Sep 17	additional note added for French casements below 1100mm	PG
4.07.1	Jan 17	Sep 17	Additional T & T Hardware added	PG
4.08.1	Jan 17	Sep 17	Additional T & T Hardware added	PG
3.14.1	Jan 17	Sep 17	End cap dimensions corrected	PG
1.02.1	Jan 17	Sep 17	102296 82mm Z added	PG
1.02.1	Sep 17	Feb 18	113423 additional variants added	PG
1.02.2	Sep 17	Feb 18	Additional paragraph added with recommendations when using 107218 & 107228 beads	PG

