



Delivering Excellence, Building Solutions.

**CREATING
EXCELLENCE
IN BUILDING
SOLUTIONS**

**METAL DOOR &
WINDOW FRAMES**

FIRE RESISTANT DOORSET

CASEMENT WINDOW

ACOUSTIC



CENTRAL REGION

SELANGOR DARUL EHSAN :
Lot P. T. 1353, Jalan Kesidang 5,
Kaw. Industri Sg. Choh,
48000 Rawang,
Selangor Darul Ehsan, Malaysia
Tel : +603-6099 9999 / 9988
Fax : +603-6099 9922 / 9933

NORTHERN REGION

KEDAH DARUL AMAN :
No. E2, Jalan Cendana 4/5,
Kaw. Perindustrian Cendana,
08000 Sungai Petani,
Kedah Darul Aman, Malaysia
Tel : +604-430 0321(HL)
+604-430 4335 / 4568
Fax : +604-430 4393 / 4348 / 4849

PERAK DARUL RIDZUAN :
108 & 108A, Pekeliling Dataran
Kledang, Taman Rasi Jaya. 31450.
Menglembu. Ipoh.
Perak Darul Ridzuan, Malaysia.
Tel : +605-2811 844 / 2821 844
Fax : +605-2820 844

SOUTHERN REGION

JOHOR DARUL TAKZIM :
Lot 4452, Pt. Kampung
Abdul Rahman,
82200 Benut, Pontian,
Johor Darul Takzim, Malaysia
Tel : +607-690 9926 / 9929
Fax : +607-690 9928

EAST COAST

KELANTAN DARUL NAIM :
Lot 1493, Kaw. Perindustrian Pengkalan Chepa II,
Seksyen 44, Mukim Panchor, Daerah Kemumin,
16100 Kota Bharu, Kelantan Darul Naim, Malaysia
Tel : +609-774 1127 / 1128
Fax : +609-609-774 1130 / 1131

EAST MALAYSIA

SABAH :
Lot No.11A, Jalan 3 KKIP Timur, Industrial Zone 13,
KKIP Telipok, 88460 Kota Kinabalu, Sabah. Malaysia
Tel : +6088 408 919
Fax : +6088 408 919



Zincalume®

THI HARDWARE TRADING SDN BHD (567864-W)

The information and illustration contained herein are for guidance only. Care has been taken to ensure all data and information herein is factual and numerical values are accurate at the time of publication. However, any or all technical specification, information and dimensions are nominal and provisional; they are subjected to change and variations in accordance with market conditions at the date of factual supply. No representation is made or to be implied as to the data and information herein; THUNG HING GROUP, and its subsidiary and associate companies shall not be responsible for any errors in or misrepresentation of the information contained in this brochure or its use. THUNG HING GROUP, and its subsidiary and associate companies reserve the right to alter any or all specifications as deemed fit and necessary without prior notice. Copyright © 2019 THUNG HING GROUP.

Ver 3.1

Visit Us At:
THUNG HING GROUP



THI METAL DOOR & WINDOW FRAMES

With sophisticated roll-forming technology, we have the capabilities of producing precision and quality frames.



THI Metal Door and Windows Frames are fully researched, designed and manufactured by Thung Hing's ISO 9001:2015 Quality Management System certified plant. This includes metal door accessories such as hinges, lock pocket/striker plate, lockset and many more.

Thung Hing emphasises producing high quality building material as the products form crucial parts of a building and the safety of the building occupants is utmost importance. Therefore, Thung Hing uses top quality metal material in producing its metal door and window frames. All THI™ Metal Doors and Window Frames are made from Zinalume® or Galvanneal coated metal. These materials have passed through the stringent local and international industrial quality standards as well as international client demands.

Thung Hing also ensures all products are made to last long and to withstand the forces of nature. All THI™ Metal Door and Window Frames are galvanization as well to protect if from rusting.

The sophisticated Cold Roll Forming technology used in the fabrication process also further enhances the frames durability and strength against impact.

The products has been utilised successfully nationwide in residential and government buildings. Many more upcoming projects will also be fitted with Thung Hing's large selection of designs.

PRODUCT PROFILE OVERVIEW



Continuously improving, adapting and refining our skill sets

PRODUCT PROFILE THI™

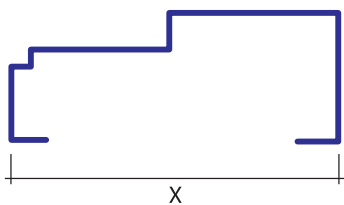

100WA~200WA

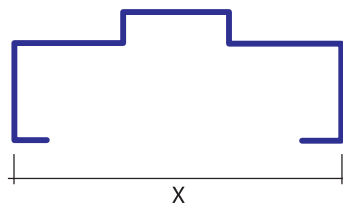

130WA~200WA

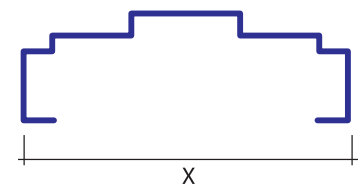

130WA~200WA

SPECIFICATIONS

Material

Hot-Dipped Galvanized, Electro Galvanized Steel, Zinalume®, and Galvanneal

Profile THI™

100WA, 105WA, 120WA, 130WA, 130KING, 140WA, 150WA, 160WA, 170WA, up to 200WA

Corners

Tagged, mitred, welded & treated

Accessories

- Hinges: Plated, 100mm loose pin slotted and welded into verticals, 3pcs per frame
- Striker Plate / Adaptor Bar
- Fish tail: 6pcs per frame

TECHNICAL DETAIL THI™ DOOR FRAME

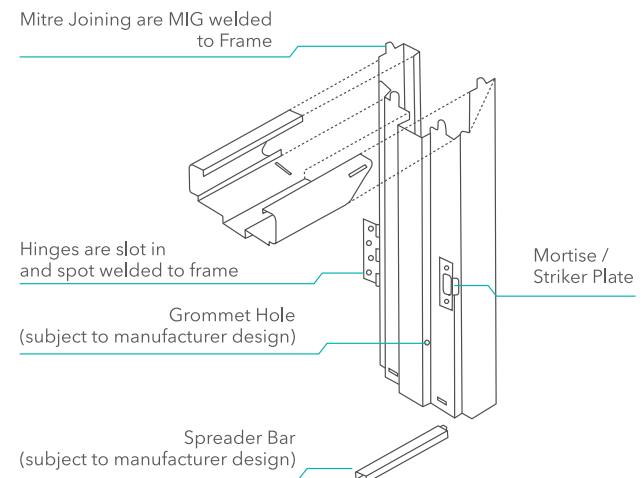

LOCATION OF HINGES / STRIKER PLATE & STRAP



Production processes with the goal of minimizing cost and maximizing value

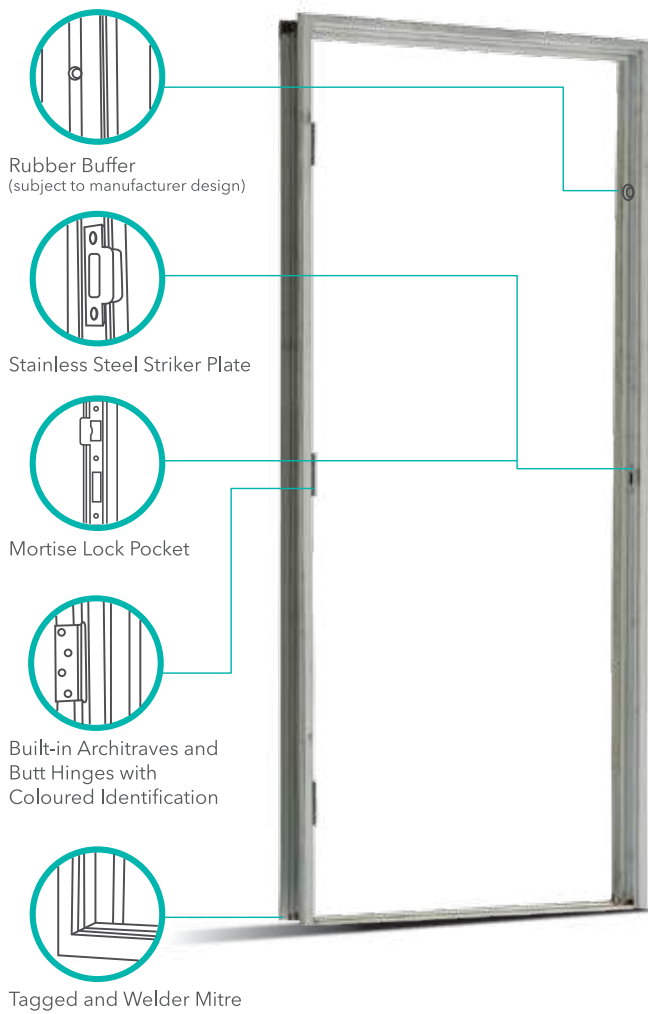

Details of typical cross section showing steel strap installation

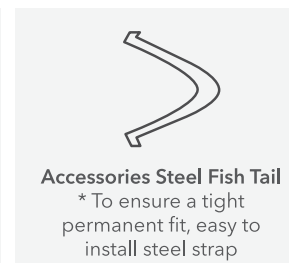
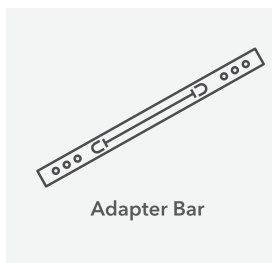
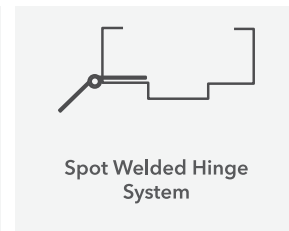
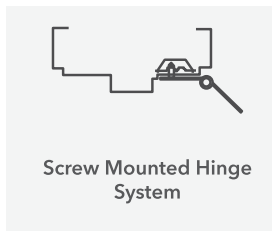
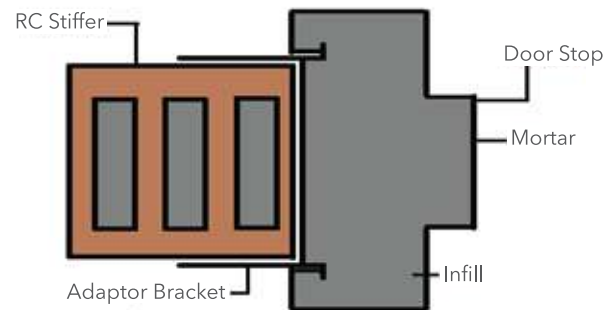

INSTALLATION PROCEDURE



Superior Product Performance with Design Flexibility



1

Mark out the area where the brickwork and the door is going to be



4

You can now proceed to lay the bricks into the rebate at the back of the frame



2

Use two lengths of timber to prop up door to standing position



5

It is important to place mortar into the gap between the brick and the frame. This is to ensure that the frame when filled with cement, will be extremely rigid and strong. Furthermore, the wall will be constructed with uniform thickness



3

Use a spirit to plumb the frame. When it's plumbed, secure the timber stays with a couple of bricks



6

Each metal door frame is supplied with a number of wire brick ties. Use them to tie brickwork every fourth of fifth brick course

ORDERING PROCEDURES

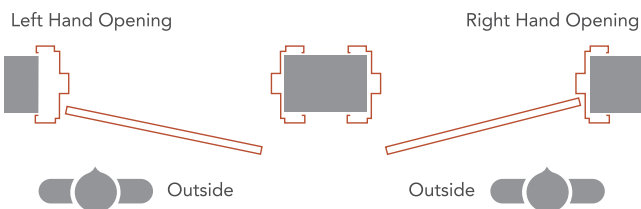

Always stand with the door opening toward you. The side with the hinges is determines the door opening (left hand or right hand)

When ordering, please specify:

1. Door frame size (External/Internal)
2. Door frame profile
3. Material type, width and thickness
4. Striker plate type
(ie: for mortise lock set or cylindrical lockset)
5. Left or right hand opening
6. Type of the Hinges
(a) GI Hinges (b) SUS 202 Hinges (c) SUS 304 Hinges

Tolerance : Thickness
for material : $\pm 0.05\text{mm}$

Overall Profile Cross:
Section Width : $\pm 3\text{mm}$

MATERIAL COLOUR



Changing construction needs and evolving industry practices

THI™ FRAME PROFILES

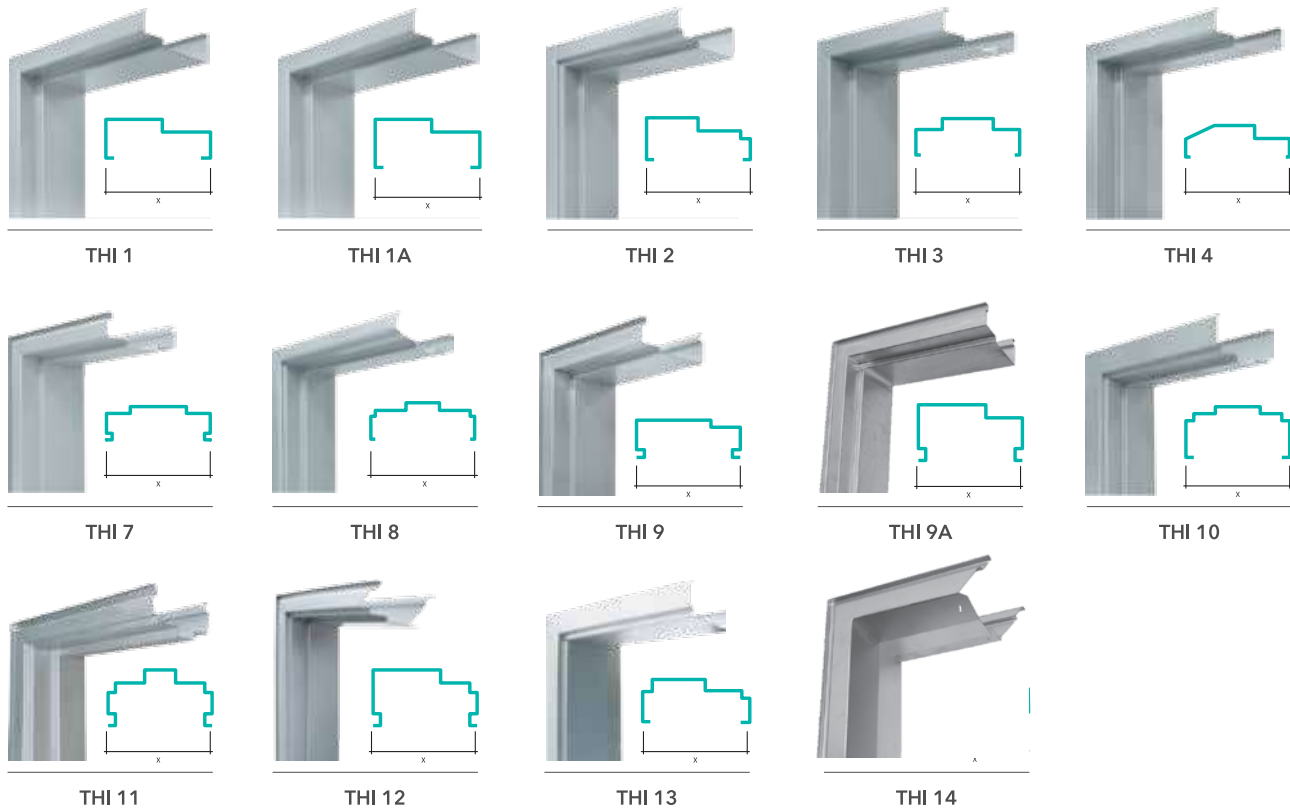

MATERIAL

Material thickness
 A. 0.80mm
 B. 1.00mm
 C. 1.20mm



Zinalume®



Hot-Dipped
(G. I.)

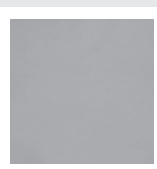

Electro Glvanized
(E.G.)

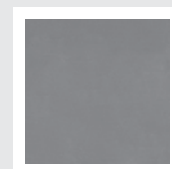

Galvanneal coated
steel (G. A.)



Zinalume®

WARRANTY & CERTIFICATE



*Terms and conditions apply



Delivering High Quality Fire Resistant Doors

Certificates

THI™ Metal Doors and Window Frames are fully researched, designed and manufactured by Thung Hing's ISO 9001:2015 Quality Management System certified plant.

CERTIFIED TO ISO 9001:2008 CERT. NO.: AR 5293

FIRE RESISTANT DOORSETS



Superior
Craftsmanship
with Elegant
Hardwood
Timber

HARMONIDOOOR

FIRE RESISTANT DOORSETS

Serai Harmoni Sdn Bhd manufactures Fire Resistant Doorsets based on ISO 9001:200 standards. With its sophisticated advanced technology, the company has the capabilities of producing precision quality products. **Serai Harmoni Sdn. Bhd.** Fire Resistant Doorsets & other accessories meet all domestic and international standards.

Serai Harmoni Sdn Bhd manufactures a full range of standard products that will suit any environment including residential, commercial industrial and JKR buildings.



DOUBLE LEAF

SINGLE LEAF

Approved by:



Certified by:



**SERAI HARMONI
SDN. BHD.**
(1053281-W)

+603-6099 9833
+603-6099 9822

enquiries@harmonidoor.com
www.harmonidoor.com

ADVANTAGES & ACCESSORIES



ADVANTAGES

- High screw holding capacity amongst fire doors
- Excellent sound insulation and acoustic properties
- Constructed of superior quality wood base materials
- Treated with fire repellent with product finishes of exceptional quality

LOCKSET, DOOR FRAME & ACCESSORIES

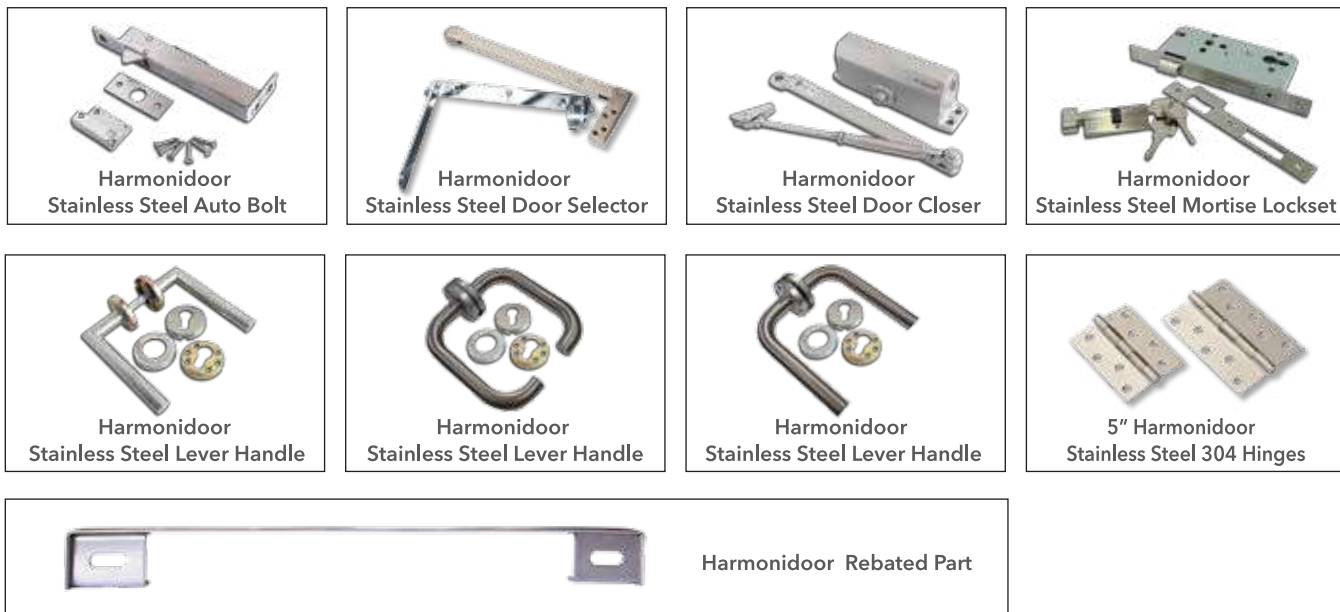

DOOR FRAME PROFILES

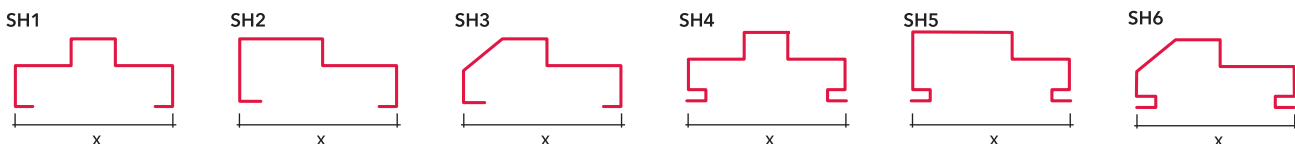

LOCKSET ACCESSORIES

5" HARMONIDOOR STAINLESS STEEL 304 HINGES

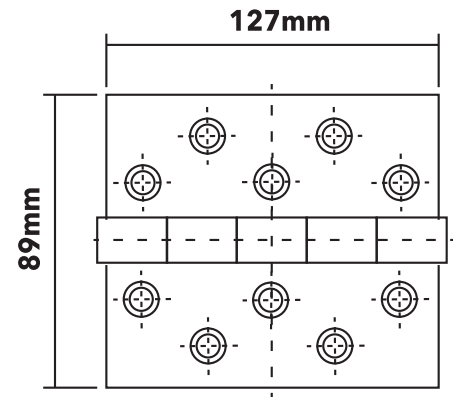
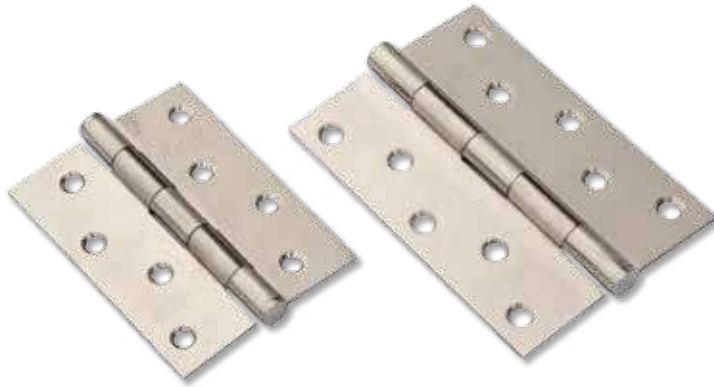

SAKURA/HARMONI HINGES

127MM X 89MM X 2.5MM SUS 304 STAINLESS STEEL HINGES.
(5" X 3.5" X 2.5MM SUS 304 STAINLESS STEEL HINGES)

SPECIFICATIONS:

- 5 Inch Hinge WITHOUT ball bearing
- Usually applied to doors that are of medium-lightweight to medium-heavy weight doors & medium to heavy usage.
- Recommended 3 to 4 nos per door/leaf depending on the door height, usually 3 nos for 2100mm x 900mm standard height & length, anything more than that requires 4 nos per door/leaf.

HARMONIDOOR STAINLESS STEEL MORTISE LOCKSET

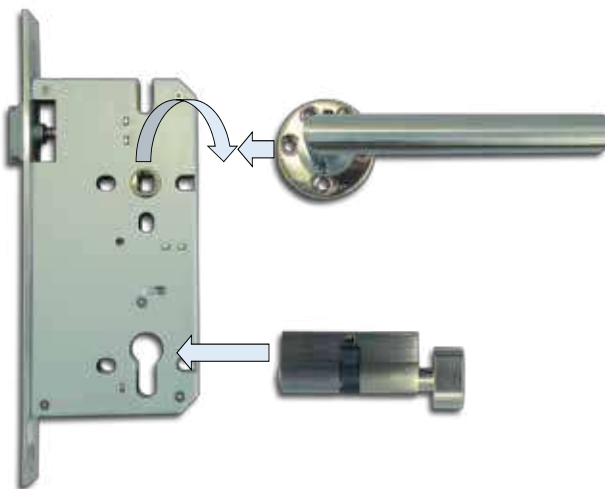

A	FOREND PLATE
B	LATCH BOLT
C	DEAD BOLT
D	SCREW CHANNEL FOR CYLINDER
E	LOCKCASE
F	ACTION-ARM
G	FOLLOWER
H	TURNING DEVICE
I	SPRING

J	BACKSET
K	DISTANCE
L	LOCKCASE WIDTH
M	LOCKCASE HEIGHT
N	FOREND LENGTH
O	FOREND WIDTH
P	LOCKCASE THICKNESS
Q	FOREND THICKNESS

CERTIFICATES & APPROVALS

- STANDARD BS EN 12209:2003
- PASSED in SIRIM QAS INTERNATIONAL Lab.
- Material Brass

SPECIFICATION FOR HARMONIDOOR EURO PROFILE CYLINDER

- Function Double Key @ Single Key & Thumbturn @ Privacy @ Half Cylinder with Thumbturn @ Half Cylinder with Key @ Thumbturn with E-slok.

LOCKSET ACCESSORIES

HARMONIDOOR STAINLESS STEEL LEVER HANDLE

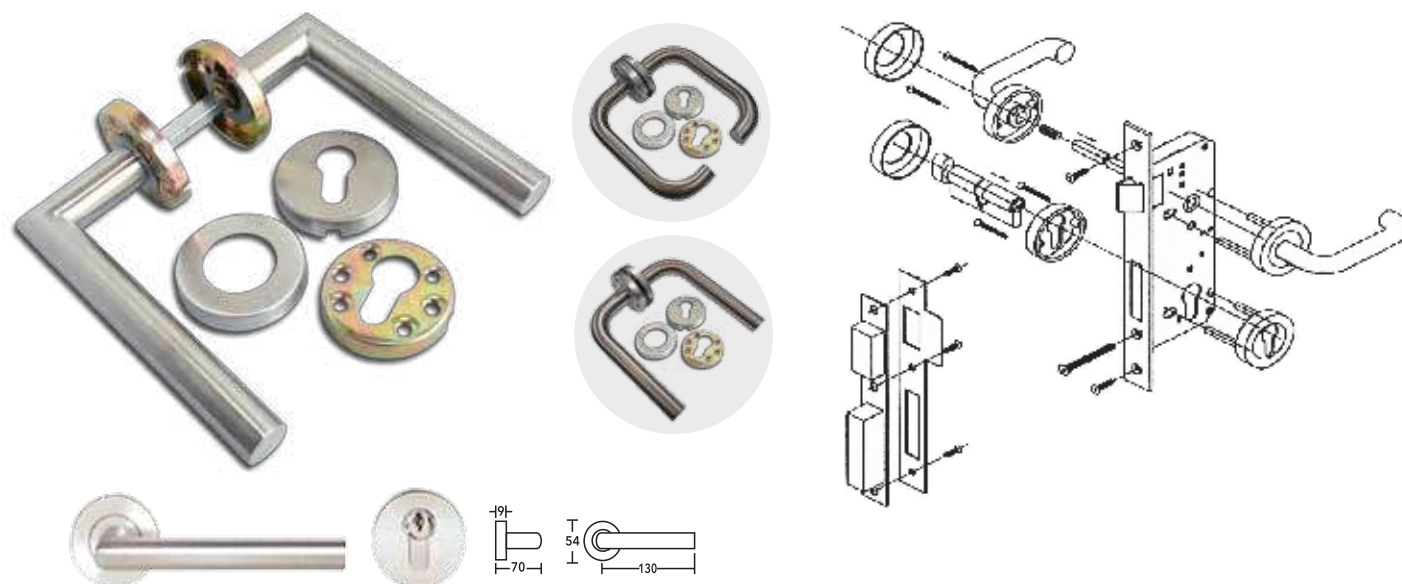

SPECIFICATIONS:

- Stainless Steel SUS304 & Zinc Diecast Handle & Rose.
- Suitable for 72mm or 85mm Centre to Centre Installation Distance.
- Applied To The Left or Right Open Door.

CERTIFICATES & APPROVALS

- STANDARD BS EN 12209:2003
- PASSED in SIRIM QAS INTERNATIONAL Lab.

HARMONIDOOR STAINLESS STEEL DOOR CLOSER

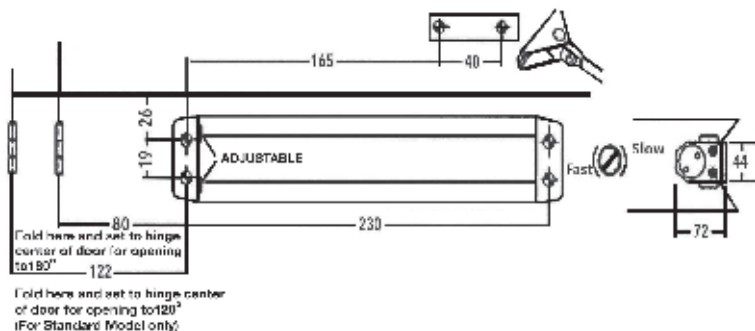

TECHNICAL INFORMATION & FUNCTION		
Model		D523BC @ D536
Backcheck Function		✓
Width of Door (mm) Max.		1500
Width of Door (kg) Max.		150
Max Open Angle		180°
Spring Strength Adjustable		3-6
Closing Speed Adjustment	Speed 1	180° - 15°
	Speed 1	15° - 0°
Applicable Temperature		-30 ~ 40
Weight (kg)		1.56kg
Dimension of Main Body	Length	248
	Width	44.5
	Height	72
Passed Durability Test		500000

CERTIFICATES & APPROVALS

- STANDARD BS EN 1154 :1997
- PASSED 500,000 Cycle in SIRIM QAS INTERNATIONAL Lab.

LOCKSET ACCESSORIES

HARMONIDOOR STAINLESS STEEL DOOR SELECTOR

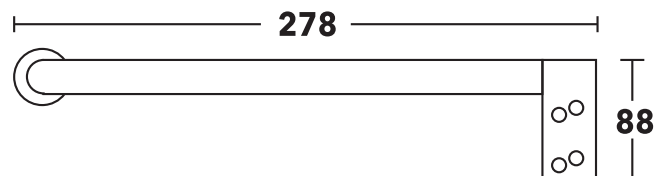

SPECIFICATION

- Stainless Steel SUS304

CERTIFICATES & APPROVALS

- STANDARD BS EN 1158 :1997
- PASSED in SIRIM QAS INTERNATIONAL Lab.

HARMONIDOOR STAINLESS AUTO BOLT

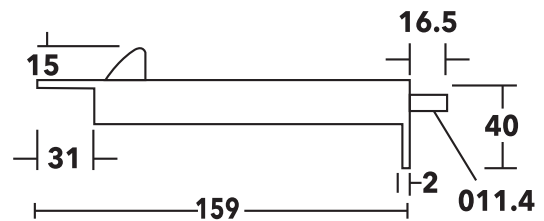

SPECIFICATION

- Stainless Steel SUS304

HARMONIDOOR REBATED PART



SPECIFICATION

Code	A	B	C	Material
Solid Brass Bortise Lock Rebated Part	152	22	9	Brass
	164	23	9	
	169	22.5	9	
	205	22.5	9	
	240	22	9	

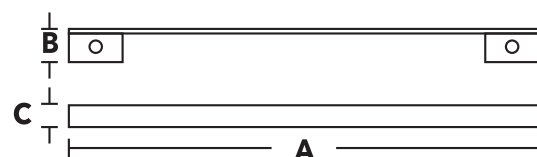

DETAIL OF DOORSET

Fire Resistant Door is resisting up to 75 minutes

SINGLE LEAF

HARMONIDOOR Fire Door Set meets the requirements of the ms 1073 Part 3 1996 (Amd 1:2003) after the completion of 100,000 cycles.

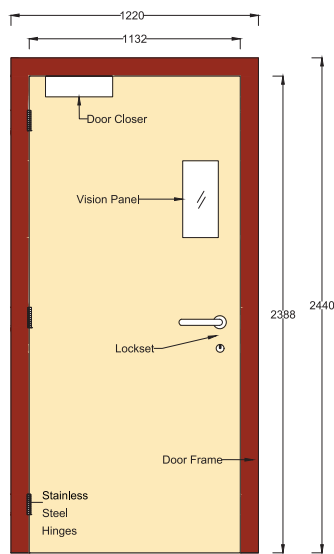

Door Frame Size - One Hour Single Leaf (maximum size 1220mm x 2440mm)

DOUBLE LEAF

HARMONIDOOR Fire Door Set meets the requirements of the MS 1073: Part 3: 1996 (Amd. 1:2003) after the completion of 50,000 cycles:

- The Door Set was capable of closing properly, maintaining all clearance between leaf to frame and floor.
- No visible signs of undue wear or damage on any part of the assembly or other defects that could impair its reliability of functioning.

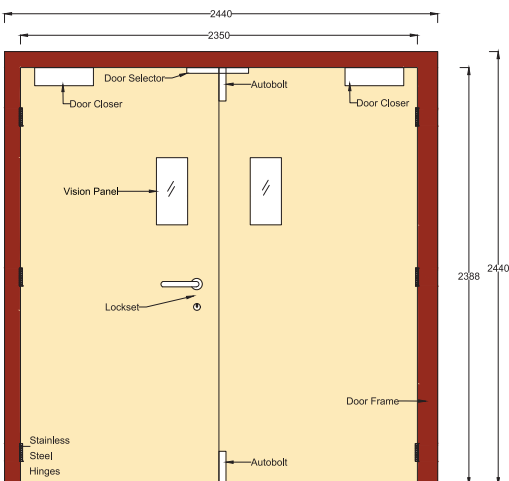

Door Frame Size - One Hour Double Leaf (maximum size 2440mm x 2440mm)

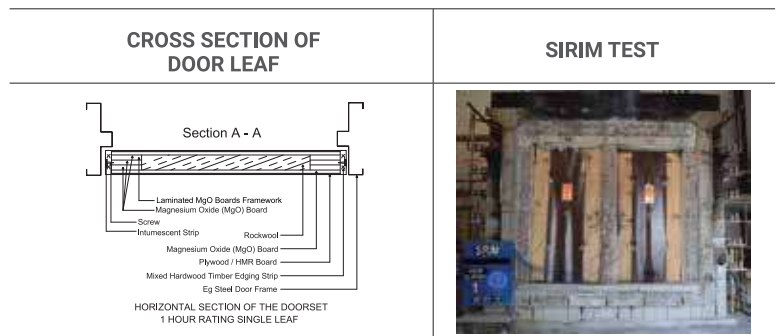
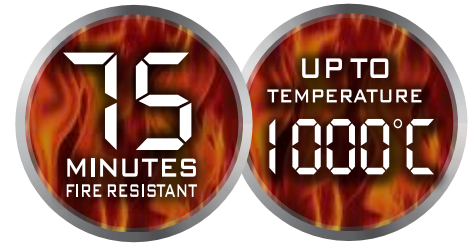

DETAILS OF DOOR FRAME
1 HOUR SINGLE LEAF & 1 HOUR DOUBLE LEAF

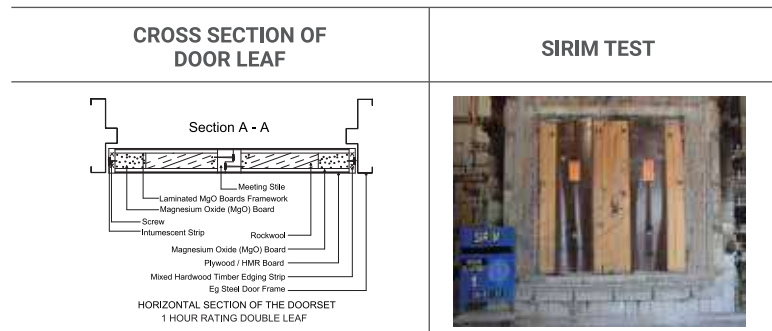
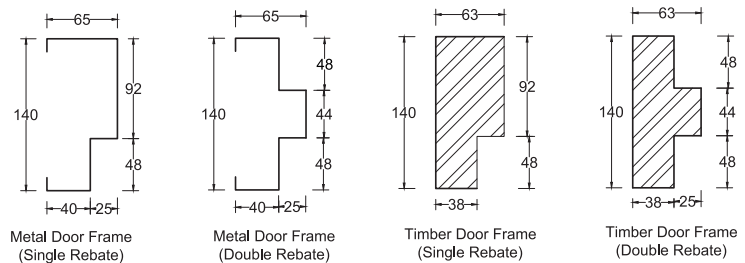

DETAIL OF DOORSET

Fire Resistant Door is resisting up to **135** minutes

HARMONIDOOR
FIRE RESISTANT DOORSETS

SINGLE LEAF

HARMONIDOOR Fire Door Set meets the requirements of the ms 1073 Part 3 1996 (Amd 1:2003) after the completion of 100,000 cycles.

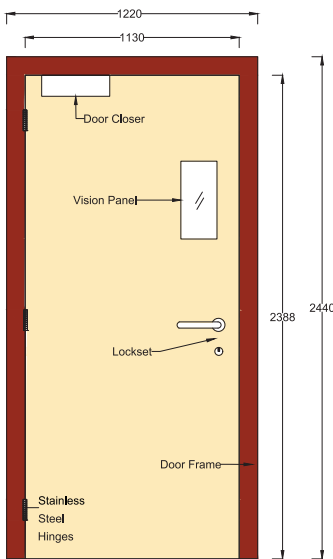
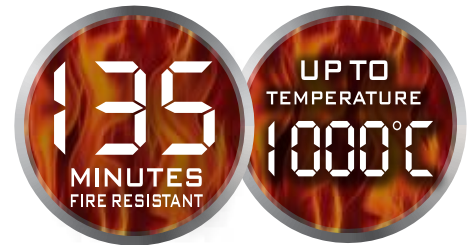

Door Frame Size - Two Hour Single Leaf
(maximum size 1220mm x 2440mm)

DOUBLE LEAF

HARMONIDOOR Fire Door Set meets the requirements of the MS 1073: Part 3: 1996 (Amd. 1:2003) after the completion of 50,000 cycles:

- The Door Set was capable of closing properly, maintaining all clearance between leaf to frame and floor.
- No visible signs of undue wear or damage on any part of the assembly or other defects that could impair its reliability of functioning.

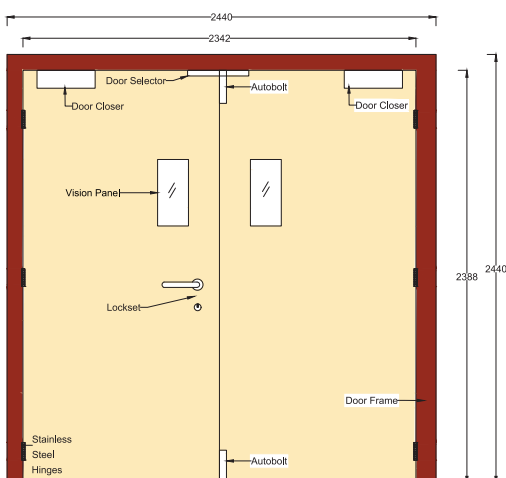

Door Frame Size - Two Hour Double Leaf
(maximum size 2440mm x 2440mm)

CROSS SECTION OF DOOR LEAF	DETAILS OF DOOR FRAME	SIRIM TEST
<p>HORIZONTAL SECTION OF THE DOORSET 2 HOUR RATING SINGLE LEAF</p>	<p>Metal Door Frame (Single Rebate) Metal Door Frame (Double Rebate)</p>	

CROSS SECTION OF DOOR LEAF	DETAILS OF DOOR FRAME	SIRIM TEST
<p>HORIZONTAL SECTION OF THE DOORSET 2 HOUR RATING DOUBLE LEAF</p>	<p>Metal Door Frame (Single Rebate) Metal Door Frame (Double Rebate)</p>	

CASEMENT WINDOW



NEW PRODUCT

- Modern design
- Faster & easy to install
- Save cost & times

front Back

METAL CASEMENT WINDOW

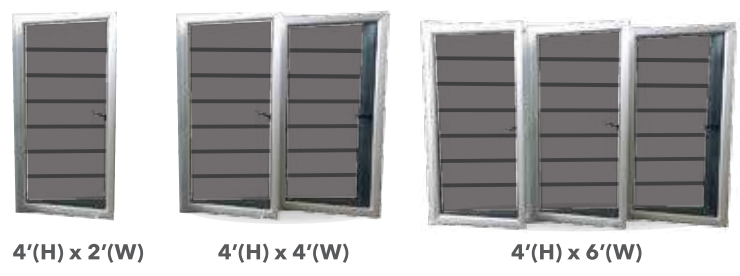

METAL SLIDING WINDOW



METAL TOP HUNG WINDOW



THI 2 IN 1 DOOR FRAME WITH GRILLE

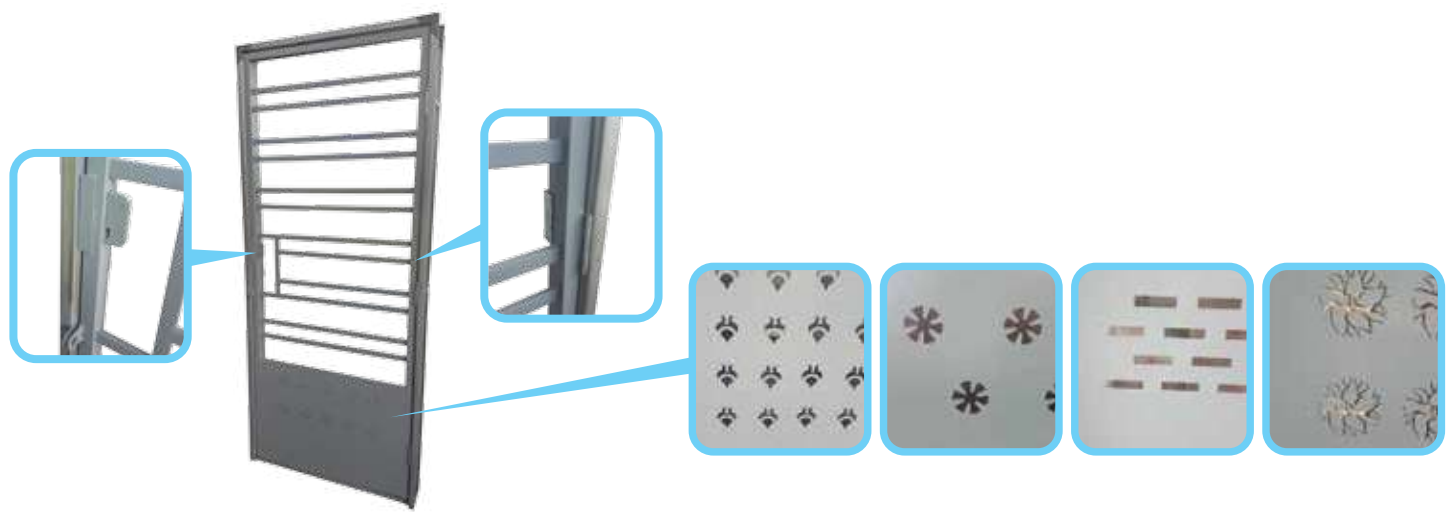

ACOUSTIC DOOR

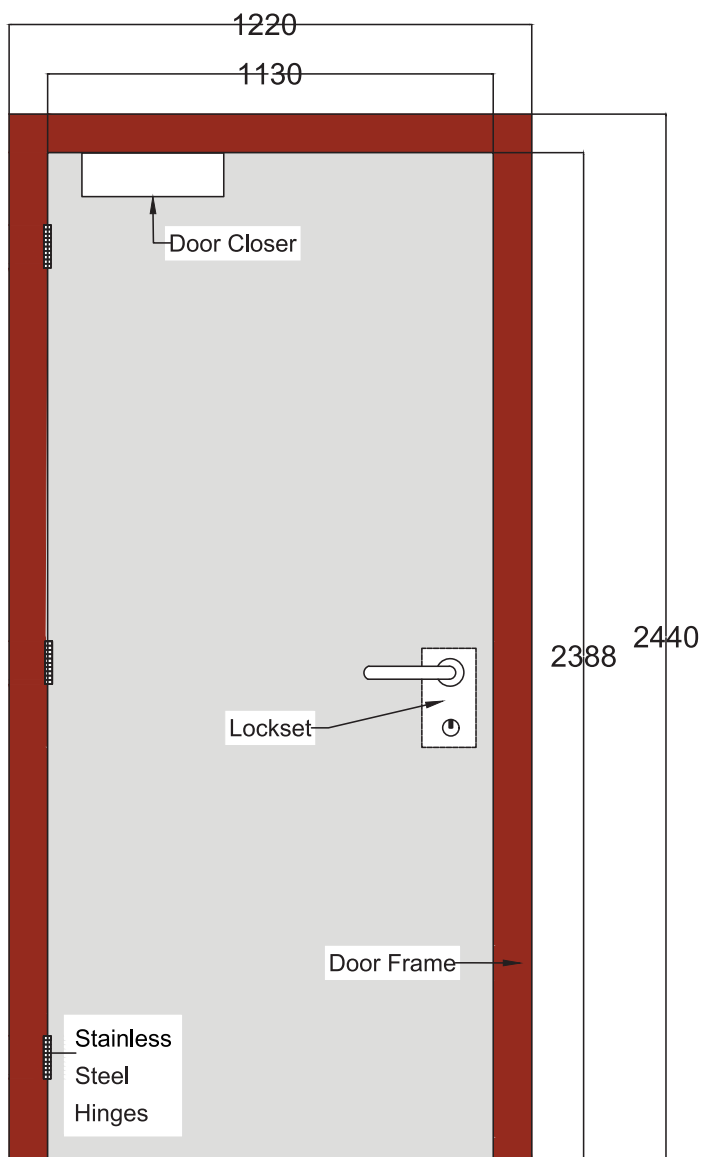

Door Frame Size - One Hour Single Leaf
(Maximum size 1220mm x 2440mm)

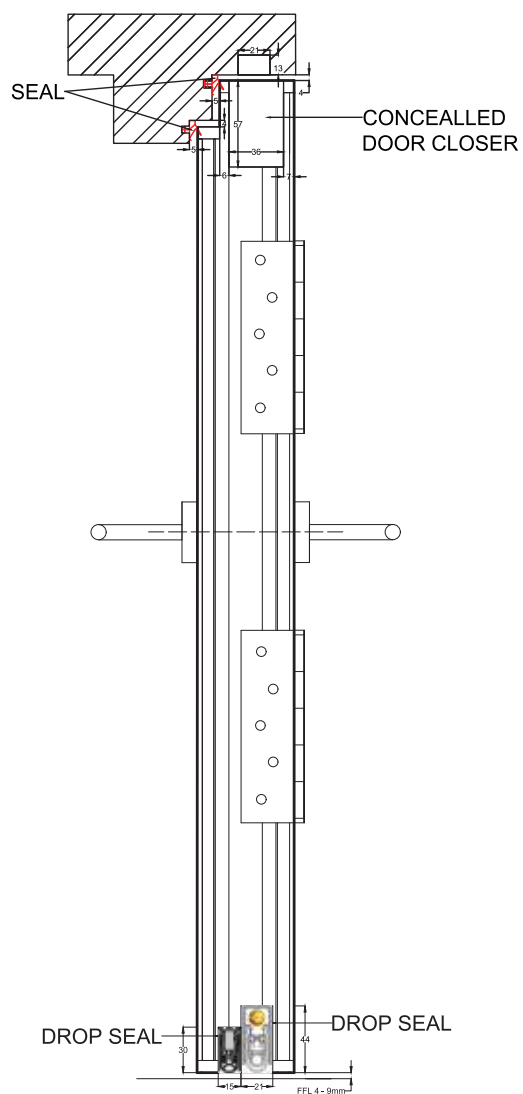

PROJECT LIST

THI HARDWARE TRADING SDN BHD (567864-W)

ITEM	LIST OF PROJECT	YEAR
1	PT1813, JALAN E3/8, TAMAN EHSAN, DAERAH GOMBAK	2018
2	LOT 1460, MUKIM TANJUNG DUA BELAS, KUALA LANGAT	2018
3	LOT 64577, JALAN DAUN INAI 20, DESA PARKCITY, MUKIM BATU, KUALA LUMPUR	2018
4	PRIMA TOK BALI, KELANTAN	2018
5	CADANGAN MEMBINA DAN MENYIAPKAN 2 BLOK KONDOMINIUM MEWAH 46 TINGKAT (328 UNITS) DENGAN 4 1/2 TINGKAT TEMPAT LETAK KERETA BAWAH PARAS JALAN PANTAI PRIMA (JALAN 112/H), OFF JALAN KERINCHI, K.L	2018
6	34 UNIT CLUSTER HOUSE, TAMAN TROPIKA KULAI (PHASE 2), JOHOR	2018
7	IMPERIAL APARTMENT, BUKIT HATAMAS	2018
8	LOT 37890, JALAN RADIN ANUM 1, BANDAR BARU SRI PETALING, MUKIM KUALA LUMPUR	2018
9	LOT 73089 - PT 73110, TAMAN SETIA IMPIAN, BUKIT ANGKAT DAERAH HULU LANGAT SELANGOR DARUL EHSAN (BLOCK A)	2018
10	LOT 44805 (BANGI AVENUE), MUKIM KAJANG, DAERAH HULU LANGAT (BLOCK B)	2018
11	SEKOLAH AGAMA TAMAN NUSANTARA LOT 35616, PTD 6912, NUSANTARA GELANG PATAH, JOHOR	2018
12	SATU BLOK BANGUNAN 4 TINGKAT DI SEKOLAH JENIS KEBANGSAAN (SJK) TAMIL, LORONG JAWA DIATAS LOT 229, DI BANDAR SEREMBAN, N.SEMBILAN	2018
13	LOT 7628, MUKIM KAJANG, DAERAH HULU LANGAT, SELANGOR	2018
14	LOT 64577, JALAN DAUN INAI 20, DESA PARKCITY, MUKIM BATU, K.L	2018
15	87 UNITS DSSO AT TAMAN PULAI HIJAUAN (PHASE 9), JOHOR	2018
16	LOT PT BERA 2/B/2016/15, BANDAR BERA 35, MUKIM TRIANG PAHANG	2018
17	SKYLUXE - 2 BLOCK SERVICES APARTMENT AT LOT 36464 & 364652018 MUKIM PETALING, BUKIT JALIL KUALA LUMPUR	2018
18	JALAN SENAWANG PERDANA SUNGAI GADUT, TAMAN PINGGIRAN SENAWANG SEREMBAN (PH II-S/STOREY)	2018
19	LANDMARK FOREST CITY, JOHOR BHARU	2018
20	KUARTERS IMIGRESEN PENGKALAN HULU LOT 2175, AYER PANAS, BETONG MKM PENGHULU PERAK	2018
21	235#DSCCH PHASE 1M II-1A,B,C TMN SCIENTEX MERU 2,HULU KINTA,DAERAH KINTA,PERAK	2018
22	49#UNITS 2 STOREY SHOP HOUSES PHASE SN 11B,SCIENTEX SENAI,JOHOR	2018
23	THE PARK 2-BANDAR BUKIT JALIL OFF LEBUHRAYA BUKIT JALIL K.L	2018
24	LOT 11041, PM 99 & LOT 11042,PM 101 MUKIM BANGAU,DAERAH TEMERLOH, TAMAN PAYA PULAI, PAHANG	2018
25	LOT 50697,JLN TIRAM 3, KUANTAN,PAHANG (SEMI-D (16 UNITS)	2018
26	478 UNITS SOHO, BANDAR SERENIA AMPAR TENA DALAM MUKIM DENGKIL, DAERAH SEPANG	2018
27	TAMBAHAN KEMUDAHAN SUKAN DI UNIVERSITI UTARA MALAYSIA SINTOK,KEDAH	2018
28	220 UNITS (RRM) BANDAR SERI BANDI KEMAMAN, TERENGGANU	2018
29	98# KEDAI PEJABAT 3 TINGKAT SN23 SCINTEX SENAI 2, JOHOR	2019
30	200# DOUBLE STOREY TERRACE HOUSE - PHASE MD8A2, SCINTEX DURIAN TUNGGAL, MELAKA	2019
31	2 BLOK KONDOMINIUM MEWAH 46 TINGKAT (328 UNITS) DENGAN 4 1/2 TINGKAT TEMPAT LETAK KERETA BAWAH PARAS JALAN PANTAI PRIMA (JALAN 112/H) OFF JALAN KERINCHI 158U SHOP LOT AT AUSTIN HEIGHT, JOHOR BHARU	2019
32	PEMBINAAN RUMAH KELUARGA ANGKATAN (RKAT) PELBAGAI JENIS DI KEM TOK JALAI, KELANTAN	2019
33	LOT 5024 - 5028, MUKIM TERIANG DAERAH BERA, PAHANG	2019
34	179U - LOT 28044 (PN 58705), MUKIM BUKIT BATU, DAERAH KULAJAYA,JOHOR	2019
35	8261 - PANGSAPURI BLOK A & B, LOT 20028, JALAN COCHRANE SEKSYEN 90 (NEAR IKEA) KUALA LUMPUR	2019
36	P157 - APARTMENT SUASANA (PH2&3) AT DAMANSARA DAMAI	2019
37	PPR SUNGAI TIRAM, BT 17 JALAN BASIR, SUNGAI TIRAM JOHOR	2019
38	THE PARK 2 PROJECT (PARCEL F), PUSAT BANDAR JALAN JALIL UTAMA 2, BUKIT JALIL, 57000 KUALA LUMPUR	2019
39	CADANGAN MEMBINA 2 BLOK RUMAH PANGSA KOS SEDERHANA 17 TINGKAT (404 UNIT) DI ATAS LOT 3244 (GM210) DAN LOT 35641 (LOT ASAL 3248 (GM358), MUKIM RASAH DAERAH SEREMBAN, NEGERI SEMBILAN	2019
40	TIARA SENDAYAN PRECINT 3 @ BANDAR SRI SENDAYAN, N.SEMBILAN	2019
41	50 UNITS DSTH & 65 UNITS TOWN HOUSE AT AMPANGAN, SEREMBAN	2019
42	3 STOREY SUPPER LINK HOUSE @ JALAN LAKSAMANA 10, KLANG	2019
43	MONT JADE BUNGALOWS, LOT 5539-5542, MKM SEREMBAN, N.SEMBILAN	2019
44	SEKOLAH BIMBINGAN JALINAN KASIH LORONG HJ HUSSEIN 2, JALAN CHOW KIT K.L	2019
45	KOLEJ POLY-TECH MARA (KPTM), LOT 339325, BANDAR BARU MERU RAYA MK HULU KINTA, DAERAH KINTA, IPOH	2019
46	LOT 3292, JALAN TANJUNG KARANG (LORONG MASTAM), KLANG	2019
47	LOT 4098, JALAN TANJUNG RHU (LORONG HJ HUSSAIN), KLANG	2019
48	LOT 1926-1942 & LOT 2121, MUKIM RIM, DAERAH JASIN MELAKA	2019
49	LOT 4803, PERSIARAN MASJID SULTAN 19E/KS13, KAMPONG TELUK NIPAH 42920 PULAU INDAH	2019
50	AD3B2 - ALAM DAMAI, PERSIARAN DAMAI, ALAM DAMAI CHERAS MUKIM PETALING, K.L	2019
51	LOT 31 -36, SEKSYEN 68, JALAN AMPANG, KUALA LUMPUR	2019
52	RUMAH SELANGORKU, NO 1 (LPT 39829), JALAN NOVA U5/86A, SUBANG BESTARI SEKSYEN U5, 40150 SHAH ALAM, SELANGOR	2019
53	PROJEK PEMBANGUNAN RUMAH KELUARGA ANGKATAN TENTERA DI KEM SEGAMAT, JOHOR	2019
54	CADANGAN MEMBINA 59 UNIT INDUSTRI 1 1/2 ATAS LOT 1650 HINGGA 1710, JALAN CEMPAKA1, KAWASAN PERINDUSTRIAN ANUGERAH SURIA, SG.CHOH, SEKSYEN 20 BANDAR SERENDAH, DAERAH HULU SELANGOR	2019
55	NO.36, JALAN PORTLAND, TASEK INDUSTRIAL ESTATE, 31400 IPOH, PERAK	2019
56	WISMA MONT KIARA, NO.1 JALAN KIRA, MONT KIARA, 50480 K.L	2019
57	LOT 29489 (PT 24684) HINGGA PT 24826 DAN PT 25028, BANDAR BARU NILAI MUKIM SETUL, DAERAH SEREMBAN, N.SEMBILAN	2019
58	PT 4344 - PT 4408 & PT 4483, LOT LAMA 8592, MUKIM HUJUNG PERMATANG DAERAH KUALA SELANGOR	2019
59	LOT 1192 MUKIM TELOK PANGLIMA GARANG	2019
60	MAHKAMAH SYARIAH, KUANTAN PAHANG	2019
61	30 UNITS RUMAH TERES, 3 TINGKAT DIATAS LOT 6283, JALAN BUMI HIJAU KAMPUNG PERMATA, MUKIM RAWANG, DAERAH GOMBAK	2019
62	NO.2 & 4 JALAN BK 1/19, KINRARA INDUSTRIAL PARK, BANDAR KINRARA 47100 PUCHONG, SELANGOR	2019
63	BANDAR TASIK PUTERI, RAWANG (15 TINGKAT)	2019
64	CYBERSOUTH TOWN HOUSE, MUKIM DENGKIL, SEPANG	2019
65	BANDAR SERI IMPIAN - IMPIANA BAYU 3B2, KLUANG, JOHOR	2019
66	CONSTRUCTION OF 103 UNITS TERRACE HOUSES AT ZONE C, TAMAN BUKIT DAHLIA PASIR GUDANG,JOHOR	2019
67	CONSTRUCTION OF 96 UNITS TERRACE HOUSES AT TAMAN MUTIARA GADING BATU PAHAT, JOHOR	2019
68		
69		

PROJECT LIST

SERAI HARMONI SDN BHD (1053281-W)

ITEM	LIST OF PROJECT	YEAR
1	CADANGAN KERJA-KERJA PENGUBAHSUAJ SATU (1) UNIT BANGUNAN PEJABAT ENAM (6) TINGKAT DAN SEMBILAN BELAS (19) UNIT RUANG PEJABAT TIGA (3) TINGKAT DI HARUM MAS KOTA KINABALU INDUSTRIAL PARK (KKIP) UNTUK DIJADIKAN POLITEKNIK KOTA KINABALU SABAH FASA II.	2019
2	FASA 1: CADANGAN UNTUK MENDIRIKAN: I) 5 UNIT KEDAI PEJABAT 3 TINGKAT JENIS A II) 5 UNIT KEDAI PEJABAT 3 TINGKAT JENIS B DI ATAS LOT 5735, MUKIM 11, SEBERANG PERAI SELATAN, PULAU PINANG. UNTUK TETUAN: DEMI CANGGIH (PENANG) SDN BHD (NO.SYARIKAT: 1040123-H)	2019
3	CADANGAN TAMBAHAN DAN PINDAAN KEPADA 2 UNIT PEJABAT PAMERAN BERKEMBAR 2-TINGKAT (PLOT 3 DAN 4), DI ATAS LOT BARU 10032 DAN 10033 (SEBAHAGIAN LOT LAMA 186), SEKSYEN 2, JALAN KAMPUNG PAYA, BANDAR BUTTERWORTH, SEBERANG PERAI UTARA, PULAU PINANG.	2019
4	LOT G038, GRD FLOOR, NO.1 PERSIARAN SOUTHKEY 1, SOUTHKEY JOHOR BAHRU 80150	2019
5	LOT 183, JALAN BUKIT BINTANG SEKSYEN 67, KUALA LUMPUR	2019
6	PERMOHONAN PELAN TAMBAHAN DAN UBAHAN BANGUNAN BAGI 1 UNIT KEDAI PEJABAT 3 TINGKAT DI ATAS PTD 57455, (BILL.14 & 14A), JALAN TIMAH SARI, BATU PAHAT, JOHOR	2019
7	DR HOTEL NO.12A, LINTANG SUNGAI TIRAM 5, 11900 BAYAN LEPAS, PENANG MALAYSIA	2019
8	PROJEK BEKALAN ELEKTRIK LUAR BANDAR (BELB) FASA III SISTEM SOLAR HIBRID DI KAMPUNG DAN SEKOLAH - SEKOLAH PENDALAMAN SARAWAK (SK. NANGA. BALANG, KAPIT DIVISION	2019
9	CADANGAN MEMBINA & MENYIAPKAN 4 UNIT RUMAH KEDAI 2 TINGKAT DI ATAS LOT PT 8563 & SEBUAH DEWAN SERBAGUNA SERTA KERJA-KERJA BERKAITAN DI KG MENERONG, MUKIM HULU TERENGGANU, TERENGGANU	2019
10	KAVA LIVING MID VALLEY JOHOR BAHRU 28A, JALAN UDA UTAMA 3/15, TMN BANDAR UDA UTAMA, 81200 JB	2019
11	27 TINGKAT 258 UNITS PANGSAPURI SERVIS BATU 6, OFF JALAN CHERAS K.L	2019
12	TO SUPPLY & DELIVER FULL SET OF 1 HOUR FIRE RATED DOOR.	2019
13	TELEKOM MALAYSIA BERHAD ARAS 14, MENARA TM MELAKA, MITC, 75450 AYER KEROH, MELAKA	2019
14	PROPOSED 1-UNIT 2-STOREY DETACHED NURSERY BUILDING ON LOT 3609, BLOCK 5, MIRI CONCESSION LAND DISTRICT JALAN JEE FOH 3, MIRI	2019
15	BARD SDN BHD, LOT 57C, LORONG PERUSAHAAN 5, KULIM INDUSTRIAL ESTATE KULIM 09000 MALAYSIA.	2019
16	CADANGAN MEMBINA DAN MENYIAPKAN 1 UNIT RUMAH KEDAI 2 TINGKAT (BATU) DI ATAS LOT 3445, MUKIM PASIR PUTEH, DAERAH LIMBONGAN, J AJAHAN PASIR PUTEH, KELANTAN.	2019
17	MAXIS KK TOC, CL 015551283 JALAN BURUNG KELETO, INANAM INDUSTRIAL EASTATE, 88400 KOTA KINABALU, SABAH	2019
18	SUMMER BAY LANG TENGAH ISLAND RESORT SDN BHD GM96, LOT 52, MUKIM PULAU REDANG, PASIR BESAR, KUALA TERENGGANU, TERENGGANU	2019
19	AUSTIN 18, TAMAN MOUNT AUSTIN, JOHOR BAHRU	2019
20	LAGUNA HEIGHTS CONDO, JALAN SRI LAGUNA, TAMAN LAGUNA JOHOR BAHRU	2019
21	47 SHOP OFFICE AT TAMAN PUCHONG UTAMA	2019
22	6 UNITS & 4 UNITS PERINDUSTRIAN BERKEMBAR 3 TINGKAT (86' X 160') DI ATAS LOT 2297, (NO HAK MILIK : GRN 48729), MUKIM KAJANG, DAERAH HULU LANGAT SELANGOR D.R	2019
23	LOT 11749, SHAMELIN STAR, JALAN CHERAS K.L	2019
24	MRT DEPOT BUS 994/998, JALAN SUBANG, KG BARU SG BULOH	2019
25	LOT 48623, JALAN MAMTAP 25/126, SEKSYEN 25 SHAH ALAM	2019
26	SENTROVUE, PUNCAK ALAM	2019
27	M/S DFZ TRADING SDN BHD WISMA ATLAN 8 PERSIARAN KAMPUNG JAWA, BAYAN LEPAS 11900, PENANG.	2019
28	PELAN LULUSAN UNTUK SOKONGAN SIJIL PERAKUAN BOMBA BAGI CADANGAN PELAN MENAIK TARAF SISTEM PENCEGAH KEBAKARAN DI KILANG SEDIADA NO.7, (LOT 6015) JALAN KUKUH, KAWASAN PERINDUSTRIAN TAMPOI, 80350 JOHOR BAHRU, JOHOR	2019
29	CADANGAN PINDAAN, TAMBAHAN DAN TUKARGUNA 1 BLOK BANGUNAN 5 TINGKAT KEPADA HOTEL JIMAT (44 BILIK) (PREMIS NO.140, 140A, 140B, 140C, 140D, 140E, & 140F), JALAN GURDWARA DI ATAS LOT 781, SEK. 11W, BANDAR GEORGETOWN, DTL, PULAU PINANG	2019
30	CADANGAN MEMBINA SEBUAH PEMBANGUNAN YANG MENDUNGKI: 1) 1 UNIT KILANG 1 TINGKAT II) PEJABAT 3 TINGKAT III) 1 UNIT PONDOK PENGAWAL IV) 1 UNIT KEBUK SAMPAH	2019
31	SUMMER BAY LANG TENGAH ISLAND RESORT SDN BHD GM96, LOT 52, MUKIM PULAU REDANG, PASIR BESAR, KUALA TERENGGANU, TERENGGANU	2019
32	CADANGAN MENDIRIKAN KILANG MEMPROSES ITIK YANG MENDUNGKI 1 UNIT KILANG 1 TINGKAT DI ATAS SEBAHAGIAN PT12854, BANDAR SRI SENDAYAN, DAERAH SEREMBAN, NEGERI SEMBILAN DARUL KHUSUS UNTUK TETUAN XOON HUP POULTRY FARMING SDN BHD	2019
33	SUMMER BAY LANG TENGAH ISLAND RESORT SDN BHD	2019
34	PERMOHONAN PELAN PINDAAN KEDUA KE ATAS PELAN LULUS MPJBT (JB) RP/6/16/2016 BERTARIKH 14.6.2016 BAGI CADANGAN PEMBANGUNAN BERSTRATA 5 BLOK PANGSAPURI PERKHIDMATAN 40 TINGKAT (2251 UNIT) YANG MENDUNGKI:- 1. 1 BLOK PANGSAPURI PERKHIDMATAN YANG MELIBATKAN:- i. 1 BLOK A - 33 TINGKAT (573 UNIT) 2. 4 BLOK PANGSAPURI PERKHIDMATAN YANG MELIBATKAN:- i. 1 BLOK B - 37 TINGKAT (547 UNIT) ii. 1 BLOK C - 37 TINGKAT (274 UNIT) iii. 1 BLOK D - 37 TINGKAT (272 UNIT) iv. 1 BLOK E - 37 TINGKAT (548 UNIT) 3. 3 TINGKAT PODIUM YANG MELIBATKAN:- i. TEMPAT LETAK KERETA BERSERTA 9 UNIT RUANG PERNIAGAAN DAN KEMUDAHAN - ARAS 1. ii. TEMPAT LETAK KERETA BERSERTA 9 UNIT RUANG PERNIAGAAN - ARAS 2 iii. RUANG KEMUDAHAN, 1 UNIT RUANG PERNIAGAAN DAN 37 UNIT PANGSAPURI PERKHIDMATAN - ARAS 3 4. 1 UNIT RUANG KEMUDAHAN - ARAS 4 5. 2 UNNIT PONDOK PENGAWAL	2019
35	PROPOSED INTERIOR DESIGN FOR AUSTRALIAN CLINICAL LAB AT MENARA AXIS, PETALING JAYA, 47820 SELANGOR.	2019
36	CADANGAN MEMBINA DAN MENYIAPKAN 1 UNIT RUMAH KEDAI (BATU) KEKAL 2 TINGKAT DI ATAS LOT PT 8774 (HSM 2416), TEMPAT KG DALAM RHM, MUKIM CHERANG RUKU, DAERAH SEMERAK, JAJAHAN PASIR PUTEH, NEGERI KELANTAN DARUL NAIM.	2019
37	RENOVATION WORK FOR JETPHARMA S/B NO.13, JALAN RAJAWALI 2, BANDAR PUCHONG JAYA 47100 PUCHONG SELANGOR	2019
38	SAMSUNG SDIEM BOILER ROOM FIRE RATED DOOR CHANGE LOT 635 & 660, KAWASAN PERINDUSTRIAN TUANKU JAAFAR, 71450 SUNGAI GADUT, NEGERI SEMBILAN DARUL KHUSUS, MALAYSIA	2019
39	PROPOSAL TO BUILD 2 UNIT DOOR FIRE RETARDANT DOORS TO EFCO (MALAYSIA) SDN BHD, PLO 454, ZON 10, JALAN KELULI, KAWASAN PERINDUSTRIAN PASIR GUDANG, 81700 PASIR GUDANG, JOHOR	2019
40	PELAN ""AS BUILT"" KEPADA KILANG SATU DAN DUA TINGKAT DAN GUDANG SATU TINGKAT SEDIA ADA DI ATAS LOT 3469, LORONG NENAS, BUKIT TENGAH, MUKIM 11, SEBERANG PERAI TENGAH, PULAU PINANG, UNTUK TETUAN: SYARIKAT PERUSAHAAN JOOI BERSAUDARA SDN BHD	2019
41	PINDAAN KEPADA PELAN YANG TELAH DILULUSKAN (BIL (11) dlm. MPBTG/JKB/GH/04/12/2012) JILID 2 BERTARIKH 15.05.2017 BAGI CADANGAN MENYAMBUNG SEMULA PROJEK TERBENKALAI UNTUK PEMBANGUNAN BERCAMPUR YANG MENDUNGKI:	2019
42	FASA 4: BLOK 4 PANGSAPURI 26 TINGKAT (209 UNIT), - RUANG PERNIAGAAN PERSENDIRIAN	2019
43	BANDAR CYBER HOTEL BOTANI LOT 4 & 6, NO. 2, JALAN LAPANGAN SIBER 9, BANDAR CYBER, 31350 IPOH MUKIM HULU KINTA, PERAK DARUL RIDZUAN.	2019
44	TETUAN BF AUTOMATION SDN BHD PT 5228, JALAN CASSIA SELATAN 3/8, TAMAN PERINDUSTRIAN BATU KAWAN, MUKIM 13 SEBERANG PERAI SELATAN.	2019
45	1219, LORONG BUKIT MINYAK 22, PENANG SCIENCE PARK, 14100, SIMPANG AMPAT, PULAU PINANG.	2019
46	CADANGAN 4 BLOK PANGSAPURI PERKHIDMATAN 25 TINGKAT (1255 UNIT), 5 TINGKAT RUANG LETAK KERETA, RUMAH KELAB, 4 UNIT RUMAH SAMPAH & 1 UNIT PONDOK PENGAWAL DI ATAS LOT 156268, JLN SUTERA KUNING, MUKIM PULAI, DAERAH JOHOR BAHRU, JOHOR.	2019
47	CADANGAN PINDAAN DAN TAMBAHAN 1 UNIT KILANG 3 TINGKAT DENGAN PEJABAT 3 TINGKAT KEPADA KILANG SEDIADA NO. 2580, DI ATAS PT 2709 (LOT 4830), TINGKAT PERUSAHAAN 4B, KAWASAN PERINDUSTRIAN BEBAS PERAI, MUKIM 1, SEBERANG PERAI TENGAH, PULAU PINANG.	2019
48	CADANGAN TAMBAHAN DAN PERUBAHAN SERTA TAMBAHAN 4 BUAH GELANGGANG FUTSAL (TERBUKA) DAN 17 BUAH GELANGGANG BADMINTON (TERTUTUP) DI TINGKAT 3 PADA SATU BLOK BANGUNAN PERDAGANGAN 5 TINGKAT SEDIA ADA DI ATAS LOT-LOT PT. 25817 (LOT PT 44656, PT 44657, PT 44658 DAN PT 44659 - LOT LAMA) NO.3, JALAN 7A/62A BANDAR MENJALARA, MUKIM BATU, KUALA LUMPUR. UNTUK: TETUAN TESCO STORE (M) SDN BHD	2019