



## Infrared Technology For Wood Processing

Victory's Fast Bake Oven & VLP15 infrared systems are two products that make short work of wood processing.

Both systems provide an effective heating solution which is energy efficient, cost effective and time saving.



The Victory Infrared Fast Bake Oven is a system which has been designed to meet the needs of busy manufacturers.

Victory has a long history of developing infrared products for a variety of applications including automotive & plastics.

The Fast Bake Oven draws on that experience to offer a much needed solution for fast & efficient drying of finishes, adhesives etc. on wood products such as doors, panels, window frames, cupboards etc.

Due to fast drying times & even heat distribution, finishes are at less risk of contamination and defects.

### Controllable Heat

- Fast Drying Times
- Instant Heat From Switch On
- Mobile Racking Easily Moved In & Out Of The Oven

The Fast Bake Oven is supplied in a flat pack format with easy to follow assembly instructions, each Fast Bake Oven is supplied with 4 x 1500W heater cassettes - each mountable in three standard height positions for your own unique application.

The cassettes are fully dimmable, allowing you the flexibility to control your heat requirements for individual job.

The Fast Bake Oven is not supplied with any controllers as standard, due to the many variable customer needs. Optional controllers however are available for Victory.

Please contact us to discuss your requirements.



### Standard Fast Bake Oven Range

Code	Width (mm)	Depth (mm)	Height (mm)	Watts (W)
FBO1	1650	1100	2000	4 x 1500
FBO2	2200	1100	2000	4 x 1500

Looking for a smaller more portable solution?  
See page 2 for the VLP15

## The VLP15

The VLP15 is a three lamp stand mounted infrared unit. It is perfect for smaller projects or to compliment larger systems.

The unit comes with three 500 watt shortwave Gold lamps with R7 fittings. These lamps provide efficient infrared heat while reducing glare.

Wide angle reflectors help to direct the infrared waves, allowing for the unit to provide a large coverage area.

### Flexible, Efficient Drying

- Fitted With 3 x 500W Short Wave Gold Lamps
- Wide Angle Reflector
- 3M Of Flexible Cable
- Built In Isolating Switch
- Optional (6 FT) Chrome Plated Stand
- Full Height 'Side & Lock' Heater Bracket
- R7s Lamps For Easy Lamp Replacement

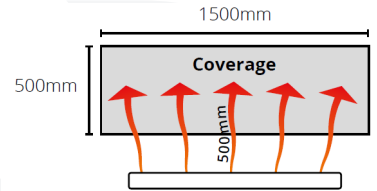

Area coverage @ minimum operating distance of 500mm = 1500 x 500mm



VLPT  
0-99 Minute  
Timer

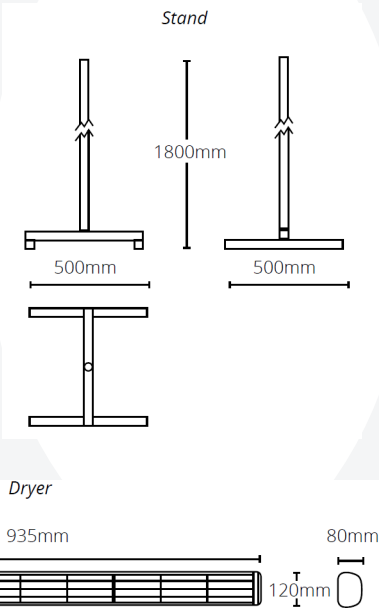

Code	Watts	
VLP15	Cassette Only	1500
HLPS Stand	Stand	
VLPTD	Timer Only	

### Supplied With

- 3 x 500W Lamps
- 3m Cable

### Optional Extras

- HLPS 1.8m Stand & Slide & Lock Bracket
- VLPTD 0-99 Minute Timer

© Victory Lighting (UK) Ltd 2021

The information contained in this literature is for general information purposes only. Victory Lighting (UK) Ltd endeavours to keep the information up to date and correct, but makes no representations or warranties of any kind, express or implied, about the completeness, accuracy, reliability, suitability or availability with respect to the information, products, services, or related graphics contained in this literature.

Victory Lighting (UK) Ltd accepts no liability for any loss or damage including without limitation, indirect or consequential loss or damage, or any loss or damage whatsoever arising from loss of data or profits arising out of, or in connection with, the use of this literature.