

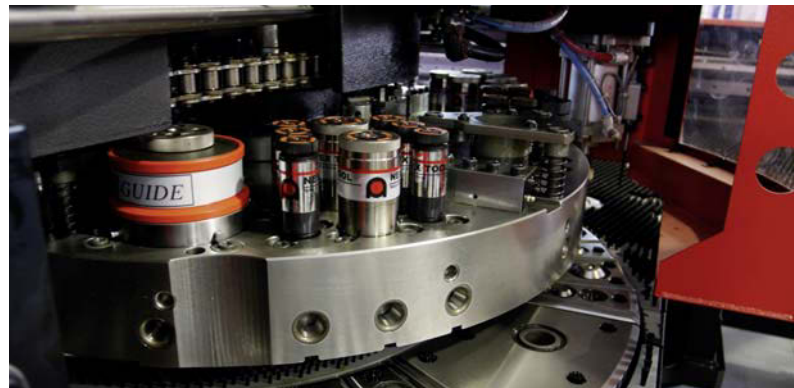

JUNIOR Line

JUNIOR Collection

Quality guaranteed by modern production facilities
Calidad garantizada por moderna maquinaria de producción
Garantida pela produção em instalações modernizadas

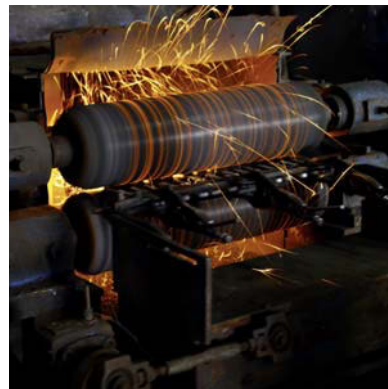

Our further products to be found
in the special catalogues:

*Nuestros productos adicionales
se encuentran en los catálogos especializados:*

Os nossos outros produtos poderão
ser encontrados nos catálogos especiais

















General Collection





LIGHT Collection

WORK+FASHION
Collection

Socket wrench case
Estuche de llaves de vaso
Mala de chaves de caixa

-   12 4-4.5-5-5.5-6-7-8
9-10-11-12-13 mm
-   1/4"  1/4"
-  50 mm
-   Art. 1000
-   2  4-5.5 mm
-  2  PH 1-2
-  2  PZ 1-2
-  5  T15-T20-T25-T30-T40

Art.		
1003	1/4"	1/4"



























   **26**
PCS



 163 x 80 x 35 mm

ABS

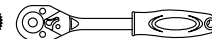
Socket wrench case
Estuche de llaves de vaso
Mala de chaves de caixa

-   13 4-4.5-5-5.5-6-7-8-9
10-11-12-13-14 mm
-   3  4-5.5-6.5 mm
-  3  PH 1-2-3
-  3  PZ 1-2-3
-  8  T8-T10-T15-T20-T25
T27-T30-T40
-  5  3-4-5-6-8 mm
-   1/4"  1/4"
-  2 50 / 100 mm
-   1/4"  1/4"
-  150 mm
-   1/4"
-   Art. 1000
-   6 1-1.27-1.5-2-2.5-3 mm

Art.	
1007	1/4"



















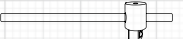
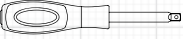

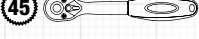













 **CrV**  **48**
PCS





 250 x 150 x 51 mm

Socket wrench and bit case
Estuche de llaves de vaso y puntas
Mala de chaves de caixa e bits

1/4" 1/4"  **88**
PCS

-  13  4-4.5-5-5.5-6-7-8-9
10-11-12-13-14 mm
-   1/4"  1/4"
-   1/4"  1/4"
-  2 50 mm / 100 mm
-  150 mm
-  115 mm
-   1/4"
-  6  1-1.27-1.5-2-2.5-3 mm
Art. 1000
-  6  4-4.5-5.5-6-6.5-8 mm
-  5  PH 0-1-2-3-4
-  4  PZ 1-2-3-4
-  15  T8-T10-2xT15-3xT20-3xT25
T27-2xT30-2xT40
-  8  T8-T10-T15-T20-T25-T27-T30-T40
-  6  3-4-5-6-7-8 mm
-  5  2-3-4-5-6 mm
-  3  No. 6-8-10
-  4  No. 1-2-3-4
-  4  No. 4-6-8-10
-   1/4"  1/4"

Art.		
1008	1/4"	1/4"















250 x 150 x 51 mm



Swiss Design by KRAFTWERK

Socket wrench case
Estuche de llaves de vaso
Mala de chaves de caixa

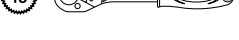
3/8"  **26**
PCS

-  15 6-7-8-9-10-11-12-13-14
15-16-17-18-19-22 mm
-  4 10-13-17-19 mm
-  2 16 mm / 21 mm
-   3/8"  3/8"
-  2 75 mm / 200 mm
-   3/8"  3/8"
-  45  Art. 1010

Art.	
1012	3/8"









295 x 215 x 75 mm

Socket wrench case

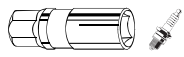
Estuche de llaves de vaso

Mala de chaves de caixa

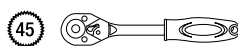
-   15 10-11-12-13-14-15-16-17-18
19-22-24-27-30-32 mm
-  2 16 mm / 21 mm
-  1/2" 1/2"
-  2 125 mm / 250 mm
-  3/8" 1/2"
-  (45) Art. 1020

Art.	<input type="checkbox"/>
1022	1/2"

1/2"  **22**
PCS



↕ 295 x 215 x 75 mm

Socket wrench case













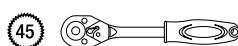

with combination spanners

Estuche de llaves de vaso

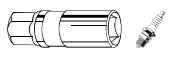
con llaves combinadas

Mala de chaves de caixa

com chaves de boca luneta

-   13 4-4.5-5-5.5-6-7-8
9-10-11-12-13-14 mm
-  1/4" 1/4"
-  1/4" 1/4"
-  2 50 mm / 100 mm
-  115 mm
-  (45) Art. 1000
-   11 15-16-17-18-19-20
22-24-27-30-32 mm
-  2 16 mm / 21 mm
-  1/2" 1/2"
-  2 125 mm / 250 mm
-  3/8" 1/2"
-  (45) Art. 1020
-  9 8-10-11-12-13-14-17-19-22 mm



Art.	<input type="checkbox"/>	<input type="checkbox"/>
1032	1/4" + 1/2"	1/4"

1/4" 1/2" 1/4" **CrV**  **84**
PCS

















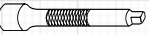
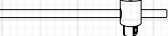
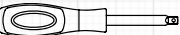

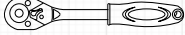





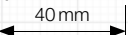



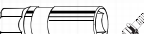

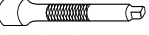

↕ 380 x 302 x 85 mm

 4 1.27-1.5-2-2.5 mm

  **Art. 1789**

Socket wrench case
Estuche de llaves de vaso
Mala de chaves de caixa

1/4" 1/2" 5/16"  **110**
PCS

-   13 ○ 4-4-5-5-5-5-6-7-8-9
10-11-12-13-14 mm
-  8 ○ 6-7-8-9-10-11-12-13 mm
-  5 ⊕ E4-E5-E6-E7-E8
-  ○ 1/4" ■ 1/4"
-  2 50 mm / 100 mm
-  115 mm
-  ■ 1/4" 150 mm
-   Art. 1000
-  3 ○ 4-5-5-6.5 mm
-  2 ⊕ PH 1-2
-  2 ⊕ PZ 1-2
-  7 ⊕ T8-T10-T15-T20-T25-T27-T30
-  4 ● 3-4-5-6 mm
- 
-   17 ○ 10-11-12-13-14-15-16-17-18-19
20-21-22-24-27-30-32 mm
-  5 ○ 14-15-17-19-22 mm
-  8 ⊕ E10-E11-E12-E14-E16-E18-E20-E24
-  2 16 mm / 21 mm
-  ○ 1/2" ○ 5/16"
-  ○ 1/2" ■ 1/2"
-  2 125 mm / 250 mm
-  ○ 3/8" ■ 1/2"
-   Art. 1020
-   3 ○ 8-10-12 mm
- 
-  2 ⊕ PH 3-4
-  2 ⊕ PZ 3-4
-  5 ⊕ T40-T45-T50-T55-T60
-  5 ● 7-8-10-12-14 mm
-  5 ● 1.25-1.5-2-2.5-3 mm

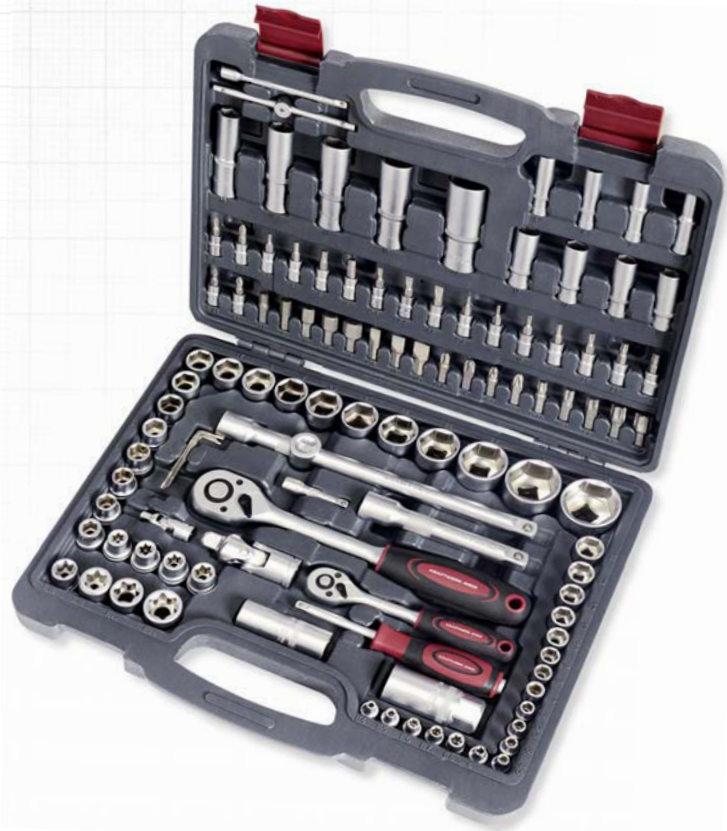

↕ 380 x 302 x 85 mm



Swiss Design by KRAFTWERK

Art.	○	●
1038	1/4" + 1/2"	5/16"

Universal socket wrench and tool case
Estuche de llaves de vaso y herramientas
Mala de chaves caixa e ferramentas



- 1/4"** 14 3.5-4-4.5-5-5.5-6-7-8-9
10-11-12-13-14 mm
- 7 4-5-6-7-8-9-10 mm
- 5 E4-E5-E6-E7-E8
- 1/4" 1/4"
- 1/4" 1/4"
- 2 50 mm / 100 mm
- 115 mm
- 1/4" 150 mm
- 1/4" 185 mm
- Art. 1000
- 4 4-5-5-6-5-7 mm
- 3 PH 1-2-3
- 3 PZ 1-2-3
- 8 T8-T9-T10-T15-T20-T25-T27-T30
- 8 T8-T9-T10-T15-T20-T25-T27-T30
- 4 3-4-5-6 mm

- 3/8"** 10 10-11-12-13-14-15
16-17-18-19 mm
- 6 10-11-12-13-14-15 mm
- 6 E10-E11-E12-E14-E16-E18
- 3 16-18-21 mm
- 3/8" 5/16"
- 3/8" 3/8"
- 150 mm
- Art. 1010

- 1/2"** 15 10-11-12-13-14-15-17-19
20-21-22-24-27-30-32 mm
- 5 16-17-18-19-22 mm
- 3 E20-E22-E24
- 1/2" 5/16"
- 1/2" 1/2"
- 2 125 mm / 250 mm
- 3/8" 1/2"
- Art. 1020
- 2 T55-T60



450 x 350 x 95 mm

- 1/4"** 3 4-5-5-6-5 mm
- 2 PH 1-2
- 2 PZ 1-2
- 5 T8-T10-T15-T20-T25
- 5 T8-T10-T15-T20-T25
- 5 TS10-TS15-TS20-TS25-TS30
- 4 3-4-5-6 mm
- 4 3-4-5-6 mm
- 3 No. 6-8-10
- 3 No. 4-6-8
- 2 No. 1-2
- 3 M5-M6-M8
- 3 No. 1-2-3

- 5/16"** 3 6-7-8 mm
- 2 PH 3-4
- 2 PZ 3-4
- 7 T25-T27-T30-T35-T40-T45-T50
- 7 T25-T27-T30-T35-T40-T45-T50
- 5 4-5-6-7-8 mm
- 4 M5-M6-M8-M10

- 7 1.27-1.5-2-2.5-3-4-5 mm

- 12 8-9-10-11-12-13-14-15-16-17-18-19 mm

Art.		
1039	1/4" + 3/8" + 1/2"	1/4" + 5/16"





13
PCS

Pass-through socket wrench set

with **reversible** offset wrench 14 x 17 mm, versatile applicable as high torque go-through ratchet handle.

Juego de llaves de vaso abiertas

con llave **reversible** con carraca de gran capacidad, acodada, 14x17mm.

Jogo de chaves de caixa de aperto

com sistema de roquete **reversível** 14x17mm, equivalente a um roquete permanente.



238 x 174 x 50 mm

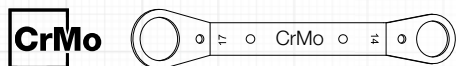

Art.	○
1017	14 + 17 mm

Reversible ratchet handle
Carraca reversible
Roquete manual reversível



Art.	■	L mm
1000	1/4"	145
1000E	1/4"	Repair-kit / Kit reparación / Kit de reparação
1010	3/8"	205
1010E	3/8"	Repair-kit / Kit reparación / Kit de reparação
1020	1/2"	255
1020E	1/2"	Repair-kit / Kit reparación / Kit de reparação



Art. 1000E / 1010E / 1020E

Universal tool case

equipped with a basic needs of tools

Maletín universal















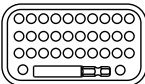

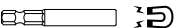



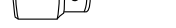

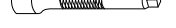













equipado con un surtido básico de herramientas



Mala de ferramenta universal

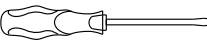

equipada com ferramentas para necessidades básicas

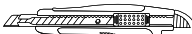
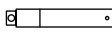

380 x 302 x 85 mm

-   8 4-4.5-5-5.5-6-7-8-9 mm
-   25 mm
-   3 4-4.5-5-5.5-6-7-8-9 mm
-  4 4.5-5.5-6.5-8 mm
-  4 PH 0-1-2-3
-  3 PZ 1-2-3
-  7 T10-T15-T20-T25
T27-T30-T40
-  7 T10-T15-T20-T25
T27-T30-T40
-  6 3-4-5-6-7-8 mm
-  1/4"  1/4"
-  1/4"  1/4"
-   9 10-11-12-13
14-15-17-18-19 mm
-   3/8"  1/4"
-   3/8"  3/8"
-   3/8"  1/4"
-  150 mm
-   3/8"  3/8"
-   Art. 1010
-  4 1.27-1.5-2-2.5 mm
-  9 1.5-2-2.5-3-4-5-6-8-10 mm
-  2 5.0 x 100 mm
6.0 x 100 mm
-  2 PH1 x 75 mm
PH2 x 100 mm
-   1/4" x 100 mm

-  160 mm
-  160 mm
-  150 mm
-  300 g
-  3 9 mm
-  10 9 mm
-  3 m x 16 mm
-  8 8-10-11-12-13-14-17-19 mm

Art.		
1042	1/4" + 3/8"	1/4"

Universal tool case

for the professional and the demanding DIY-er for the daily use.

Maletín universal de herramientas

para el profesional y bricolador exigente para un uso diario.

Conjunto universal de ferramentas







de uso profissionais e diário.















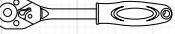









410 x 353 x 93 mm













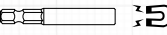





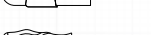



Swiss Design by KRAFTWERK

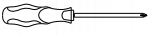
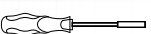

- 

17

6-7-8-9-10-11-12-13-14-15
16-17-18-19-21-22-24 mm
- 
2

16 mm / 21 mm
- 

3/8"

1/4"
- 
75 mm
- 

Art. 1010
- 

4

4.5-5.5-6.5-8 mm
- 
4

PH 0-1-2-3
- 
3

PZ 1-2-3
- 
7

T10-T15-T20-T25-T27
T30-T40
- 
7

T10-T15-T20-T25
T27-T30-T40
- 
6

3-4-5-6-7-8 mm
- 

1/4"

1/4"
- 

1/4"

1/4"
- 
8
8-10-11-12-13-14-17-19 mm
- 
200 mm / 8"
- 
9

1.5-2-2.5-3-4-5-6-8-10 mm
- 
2

3 x 75, 5 x 100 mm
- 
2

PH1 x 75, PH2 x 100 mm
- 

1/4" x 100 mm
- 
110-250 V
- 
180 mm
- 
250 mm
- 
185 mm
- 
300 g
- 
4 x 120 mm
- 
3 x 125 mm
- 
150 mm
- 
9 mm
- 
3 m x 16 mm

Art.		
1048	3/8"	1/4"

Universal tool case

for the professional and the demanding DIY-er for the daily use.

Maletín universal de herramientas

para el profesional y bricolador exigente para un uso diario.

Conjunto universal de ferramentas

para exigências profissionais e amadores.



		12	4-4.5-5-5.5-6-7-8-9 10-11-12-13 mm
			○ 1/4" ○ 1/4"
			○ 1/4" ■ 1/4"
		2	50 mm / 100 mm
			115 mm
			■ 1/4"
			Art. 1000
		13	14-15-16-17-18-19-20 21-22-24-27-30-32 mm
		2	16 mm / 21 mm
			○ 1/2" ■ 1/2"
		2	125 mm / 250 mm
			○ 3/8" ■ 1/2"
			Art. 1020
		4	4.5-5.5-6.5-8 mm
		4	PH 0-1-2-3
		3	PZ 1-2-3
		7	T10-T15-T20-T25-T27-T30-T40
		7	T10-T15-T20-T25-T27-T30-T40
		6	3-4-5-6-7-8 mm
			● 1/4" ■ 1/4"
			● 1/4" ○ 1/4"
		9	8-10-11-12-13 14-17-19-22 mm
			250 mm / 10"
		9	1.5-2-2.5-3-4 5-6-8-10 mm
		3	4.0 x 100 mm 5.0 x 100 mm 6.0 x 38 mm
		3	PH1 x 75 mm PH2 x 100 mm PH2 x 38 mm
			110-250V



↕ 540 x 390 x 110 mm

	DIN ISO 5746	180 mm
	DIN ISO 5749	160 mm
	DIN ISO 5745	200 mm
		250 mm
		185 mm
	DIN 1041	300 g
		300 mm
		3 18 mm
		6 160 mm
		5 m x 19 mm

Art.	○	●
1041	1/4" + 1/2"	1/4"

Universal tool case

ideal for mobile use and maintenance work of all kinds.

Maletín de herramientas universales

ideal para el uso móvil y mantenimiento de todo tipo.

Mala de ferramenta universal

ideal para transporte e manutenção de todos os tipos.

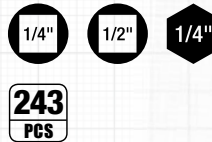

492 x 440 x 188 mm

		12	4-4.5-5-5.5-6-7-8-9 10-11-12-13 mm
			□ 1/4" ○ 1/4"
			□ 1/4" ■ 1/4"
		2	50 mm / 100 mm
			150 mm
			115 mm
			50 mm
			Art. 1000
			■ 1/4"

		17	10-11-12-13-14-15-16 17-18-19-20-21-22-24 27-30-32 mm
		2	16 mm / 21 mm
			○ 1/2" ■ 1/2"
		2	125 mm / 250 mm
			○ 3/8" ■ 1/2"
			Art. 1020



180 mm
DIN ISO 5746

160 mm
DIN ISO 5749

200 mm
DIN ISO 5745

250 mm

12 6-7-8-9-10-11-12-13
14-15-17-19 mm

250 mm / 10"

2 3.5"

6 ○ 3 x 75, 4 x 100, 5 x 100, 6 x 38
6 x 150, 8 x 150 mm

5 + PH0 x 75, PH1 x 75, PH2 x 38,
PH2 x 100, PH3 x 150 mm

2 + PZ1 x 75, PZ2 x 100 mm

○ 1/4" x 100 mm

110 - 250 V

Art.



1049

1/4" + 1/2"

1/4"

	4	○ 1.0-1.2-1.8-2.4 mm
	2	+ 3.0-3.5 mm
	4	○ 4.5-5.5-6.5-8 mm
	4	+ PH 0-1-2-3
	3	+ PZ 1-2-3
	7	* T10-T15-T20-T25-T27-T30-T40
	7	* T10-T15-T20-T25-T27-T30-T40
	6	● 3-4-5-6-7-8 mm
		● 1/4" ■ 1/4"
		● 1/4" ○ 1/4"
	9	● 1.5-2-2.5-3-4-5-6-8-10 mm
	9	* T10-T15-T20-T25-T27-T30-T40 T45-T50
		125 - 635 mm



225 mm

isol 80

300 g

12 x 130 mm

4 x 150 mm

300 mm

3 18 mm

10 18 mm

5 M 5 m x 19 mm

isol 9 m

24 LED

32012 3 AA LR06 1.5 V

Aluminium type universal tool case

highly compact, with professional tools for the daily use

Maletín universal tipo aluminio

muy compacto, con herramientas profesionales de uso cotidiano

Mala tipo alumínio de ferramentas universais

muito compacta, com ferramentas profissionais para utilização diária



- 8 4-4.5-5-5.5-6-7-8-9 mm
- 11 10-11-12-13-14-15-17-18-19-22-24 mm
- 2 16 mm / 21 mm
- 3/8" 1/4"
- 3/8" 3/8"
- 150 mm
- 3/8" 3/8"
- 3/8" 1/4"
- Art. 1010
- 4 4.5-5.5-6.5-8 mm
- 4 PH 0-1-2-3
- 3 PZ 1-2-3
- 7 T10-T15-T20-T25-T27-T30-T40
- 7 T10-T15-T20-T25-T27-T30-T40
- 6 3-4-5-6-7-8 mm
- 1/4" 1/4"
- 1/4" 1/4"
- 8 8-10-11-12-13-14-17-19 mm
- 250 mm / 10"
- 4 1.27-1.5-2-2.5 mm
- 9 1.5-2-2.5-3-4-5-6-8-10 mm
- 2 5.0 x 100 mm
- 6.0 x 100 mm
- 2 PH1 x 75 mm
- PH2 x 100 mm
- 1/4" x 100 mm
- 110-250V
- 300 g
- 150 mm
- 3 18 mm
- 10 18 mm

365 x 265 x 133 mm



- 180 mm
- DIN ISO 5746
- 160 mm
- DIN ISO 5749
- 200 mm
- DIN ISO 5745
- 250 mm
- 9 LED's
- 3m 3 m x 16 mm

Art.			
1043	1/4" + 3/8"		1/4"
1043VSM	Version with VSM Swiss norm-screwdrivers Modelo con destornilladores VSM normas Suiza Modelo com chaves parafusos VSM padrão suíço		

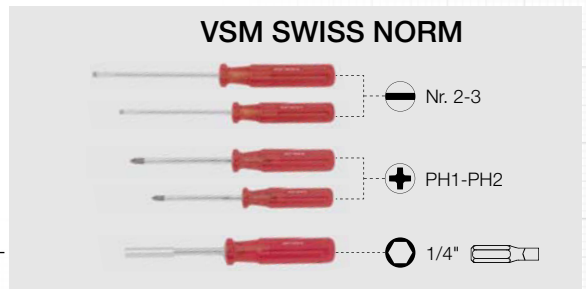

Aluminium type universal tool case

with METABO cordless drill/driver

Maletín tipo aluminio de herramientas universales

con atornillador/taladro a batería METABO

Mala tipo alumínio de ferramentas universais

com aparafusadora a bateria METABO



- 5 4-4.5-5-5.5-6 mm
- 12 7-8-10-11-12-13-14
15-16-17-18-19 mm
- 3/8" 1/4"
- 150 mm
- 3/8" 3/8"
- 3/8" 1/4"
- Art. 1010
- 4 4.5-5.5-6.5-8 mm
- 4 PH 0-1-2-3
- 3 PZ 1-2-3
- 7 T10-T15-T20-T25
T27-T30-T40
- 7 T10-T15-T20-T25
T27-T30-T40
- 6 3-4-5-6-7-8 mm
- 1/4" 1/4"
- 1/4" 1/4"
- 6 8-10-13-14-17-19 mm
- 200 mm / 8"
- 9 1.5-2-2.5-3-4-5-6-8-10 mm
- 2 4.0 x 100 mm
5.0 x 100 mm
- 2 PH1 x 75 mm
PH2 x 100 mm
- 1/4" x 100 mm
- 180 mm
DIN ISO 5746
- 160 mm
DIN ISO 5745
- 250 mm
- 110-250 V
- 60
- 178 mm



365 x 265 x 157 mm

- 1 300 g
- 1 150 mm
- 3 9 mm
- 10 9 mm
- 1 225 mm
- 1 3 m x 16 mm
- 1 **metabo**
PROFESSIONAL POWER TOOL SOLUTIONS
PowerMaxx BS
Basic
- 2 Li-Ion 10.8 V 2000 mAh
- 1 60-min

Art.		
1051	1/4" + 3/8"	1/4"
1051.1	Version with PB screwdrivers Modelo con destornilladores PB Modelo com chaves parafusos PB	

PB SWISS TOOLS

SWISSGRIP

Nr. 1, 2

PH1 - PH2

Sales only in Switzerland / Venta solo en Suiza / Venda exclusiva na Suíça

Aluminium type universal tool case

with generous and practical composition

Maletín tipo aluminio de herramientas universales

con composición generosa y práctica

Mala tipo alumínio de ferramentas universais

de composição generosa e prática



- 1/4"** 13 4-4.5-5-5.5-6-7-8-9
10-11-12-13-14 mm
- 1/4" 1/4"
- 2 50 mm / 100 mm
- 1/4"
- 45** Art. 1000
- 1/2"** 15 10-13-14-15-16-17-18-19
20-21-22-24-27-30-32 mm
- 2 16 mm / 21 mm
- 2 125 mm / 250 mm
- 1/2" 1/2"
- 3/8" 1/2"
- 45** Art. 1020
- 1/4"** 4 4.5-5.5-6.5-8 mm
- 4 PH 0-1-2-3
- 3 PZ 1-2-3
- 7 T10-T15-T20-T25-T27-T30-T40
- 7 T10-T15-T20-T25-T27-T30-T40
- 6 3-4-5-6-7-8 mm
- 1/4" 1/4"
- 1/4" 1/4"
- 9 8-10-11-12-13-14-17-19-22 mm
- 200 mm / 8"
- 9 1.5-2-2.5-3-4-5-6-8-10 mm
- 2 4.0 x 100 mm
- 6.0 x 150 mm
- 2 PH1 x 75 mm
- PH2 x 100 mm
- 1/4" x 100 mm
- 110-250V
- 180 mm
- DIN ISO 5746**
- 160 mm
- DIN ISO 5749**
- 200 mm
- DIN ISO 5745**
- 250 mm
- 200 mm
- 225 mm

455 x 340 x 160 mm

- 185 mm
- 300 g
- 4 mm
- 12 mm
- 5 mm
- 3 mm
- 4 mm
- 150 mm
- 3 18 mm
- 320 mm / No. 2
- 6 160 mm
- 150 mm
- 5 m x 19 mm
- 130-640 mm
- 1600 g
- 178 mm
- 98 mm
- 9 LED's



Art.		
1047	1/4" + 1/2"	1/4" + 4 mm
1047VSM	Version with VSM Swiss norm-screwdrivers Modelo con destornilladores VSM normas Suiza Modelo com chaves parafusos VSM padrão suíço	

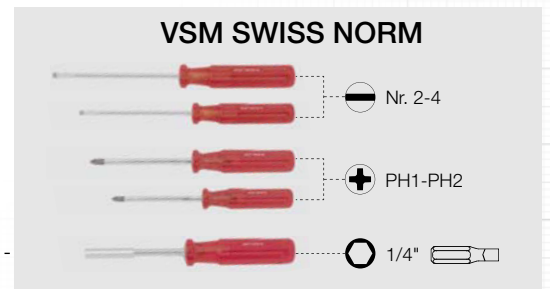

ABS tool case

with aluminium frame and edge protections.
The bottom tray is made of indestructible hard plastic material.

Maleta en ABS con herramientas

estructura en aluminio y protecciones contra golpes.
La bandeja interior esta realizada en plástico duro indestructible.

Mala em ABS com ferramentas

moldura em alumínio e cantos protegidos.
Base fabricada em material plástico indestrutível.



- 1/4" 13 4-4.5-5-5.5-6-7-8-9
10-11-12-13-14 mm
- 1/4" 1/4"
- 1/4" 1/4"
- 2 50 / 100 mm
- 115 mm
- 1/4"
- 1/4" 1/4"
- 45 Art. 1000
- 1/4" 4 4.5-5.5-6.5-8 mm
- 4 PH 0-1-2-3
- 3 PZ 1-2-3
- 7 T10-T15-T20-T25-T27-T30-T40
- 7 T10-T15-T20-T25-T27-T30-T40
- 6 3-4-5-6-7-8 mm
- 1/4" 1/4"
- 1/4" 1/4"
- 1/2" 14 10-13-15-16-17-18-19-20
21-22-24-27-30-32 mm
- 2 16 mm / 21 mm
- 1/2" 1/2"
- 1/2" 1/2"
- 250 mm
- 3/8" 1/2"
- 45 Art. 1020
- 4 mm 6 1-1.5-2-2.5-3-4 mm
- 4 PH 000-00-0-1
- 3 PZ 00-0-1
- 5 T3-T4-T5-T6-T7
- 4 T8-T9-T10-T15
- 5 1.3-1.5-2-2.5-3 mm
- 107 mm
- 105 mm
- 9 8-10-11-12-13-14-17-19-22 mm
- 250 mm / 10"
- 3.0 x 75 mm
- 4 4.0 x 100 mm
- 5.0 x 100 mm
- 6.0 x 150 mm
- 2 PH1 x 75 mm
- PH2 x 100 mm
- 2 T15 x 75 mm
- 20 x 100 mm
- 4 T25 x 100 mm
- T30 x 100 mm
- 110-250V



464 x 333 x 200 mm

- 4 1.27-1.5
- 2-2.5 mm
- 5 5 mm
- 3 mm
- 4 mm
- 9 1.5-2-2.5-3-4
- 5-6-8-10 mm
- 180 mm
- 160 mm
- 200 mm
- 250 mm
- 200 mm
- 225 mm
- 225 mm
- 50
- 185 mm
- 300 g
- 5
- 300 mm
- 3
- 18 mm
- 10
- 18 mm
- 6
- 160 mm
- 130-640 mm
- 1600 g
- 225 mm
- 5 m x 19 mm
- 0-150 mm / 6" 0.02 mm
- 40 mm
- 178 mm
- 9 LED's

Art.		
1050	1/4" + 1/2"	1/4" + 4 mm
1050.1	Version with PB screwdrivers Modelo con destornilladores PB Modelo com chaves parafusos PB	

PB SWISS TOOLS **SWISSGRIP**

- Nr. 1, 2, 3, 4
- PH1- PH2
- T15, T20, T25, T30

Sales only in Switzerland / Venta solo en Suiza / Venda exclusiva na Suíça

Universal tool-chest

Solid and handy, with big top compartment and 4 ball bearing guided drawers with tools.
Including 12 **ratchet** combination wrenches.
Central locking system.

The mobile work shop!

Armario universal de herramientas

sólido y manejable, compartimento superior y 4 cajones con rodillos de bolas, equipados con herramientas.

Incluye 12 llaves combinadas con **carraca**.

Cerradura central.

¡El taller móvil!

Baú robusto universal de ferramentas

com um compartimento grande e 4 gavetas com guias de rolamentos, composto por ferramentas.

Inclui 12 chaves de **roquete**.

Fechadura central.

A oficina portátil!

1/4" 1/2"
100
PCS



533 x 340 x 219 mm



- 11 4-5-6-7-8-9-10 11-12-13-14 mm
- 3 8-10-13 mm
- 3 4-5.5-6.5 mm
- 2 PH 1-2
- 2 PZ 1-2
- 7 T10-T15-T20 T25-T27-T30-40
- 6 3-4-5-6-7-8 mm

- 5 0.8 x 3.5 mm 0.8 x 4.0 mm 0.9 x 5.0 mm 1.1 x 6.0 mm 1.2 x 8.0 mm
- 1.1 x 6.0 mm
- 2 PH 1-2
- PH2
- 9 1.5-2-2.5-3-4 5-6-8-10 mm

- Ratchet wrench
Llave con carraca
Roquete
- 12 8-9-10-11-12-13-14 15-16-17-18 -19 mm

- 50 mm
- 125 mm
- 1/4"
- Art. 1000



Optional / Opcional / Opcional:
Art. 1046-107

- 10,8 V
2 x 2Ah

- 14 10-13-15-16-17 18-19-20-21-22 24-27-30-32 mm
- 2 17-19 mm
- 2 16 / 21 mm
- 1/2" 1/2"
- 2 125 mm / 250 mm
- 3/8" 1/2"
- Art. 1020

- 300 g
- DIN 1041 250 mm / 10"
- DIN ISO 5746 180 mm
- DIN ISO 5749 160 mm
- DIN ISO 5745 200 mm
- 250 mm
- 145 mm

- 31
- 10 1 - 10 mm

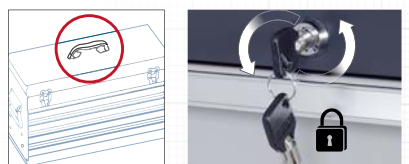

Art.	1046	1/4" + 1/2"
------	------	-------------

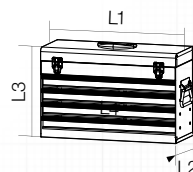

	L1 mm	L2 mm	L3 mm
	533	219	340
L4	502	187	42

Drawer tool chest

without tools

Armario de herramientas

vacío

Baú de ferramentas

sem ferramentas

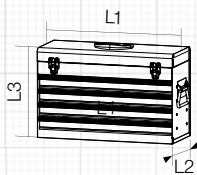

	L1 mm	L2 mm	L3 mm
	533	219	340
L4	502	187	42

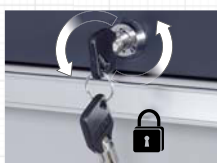

Art.

1046E

↕ 533 x 340 x 219 mm

Universal aluminium type tool case

with removable double sided tool plate and variable dividers.
Soft handle, reinforced edges.

Maletín universal tipo aluminio

bandejas dobles removibles, asa tacto suave, bordes reforzados.

Mala de ferramenta universal tipo alumínio

com divisória dupla face para ferramenta amovível e divisórias variáveis. Punho confortável, cantos reforçados.

Art.



1994

4 kg



↕ 451 x 331 x 150 mm

Tool cabinet
Carro taller
Carro de ferramentas

Art.	
------	---

1906 6

	L1 / mm	L2 / mm	L3 / mm	kg
	678	405	925	150
A	570	370	56	20
B	570	370	81	20
C	570	370	106	20
D	570	370	155	20



Tool cabinet
Carro taller
Carro de ferramentas

Art.	
------	---

1907 7

	L1 / mm	L2 / mm	L3 / mm	kg
	682	458	1000	205
A	565	395	58	25
B	565	395	138	30



Tool cabinet
with tools

Carro
con herramientas

Carro
com ferramentas







1/4" 1/2"  **337**
PCS













Art.		
1096	1906	6





 **186**
PCS

-  14 3.5-4-4.5-5-5.5-6-7-8-9-10-11-12-13-14 mm
-  6 6-8-10-11-12-13 mm
-  2 50 mm / 100 mm
-  2 125 mm / 250 mm
-  2 1/4" 1/4"
-  2 1/4" 1/4"
-  45 Art. 1000



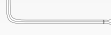













-  16 10-11-12-13-14-15-16-17-18-19-21-22-24-27-30-32 mm
-  2 16 mm / 21 mm
-  2 1/2" 5/16"
-  2 1/2" 1/2"
-  2 125 mm / 250 mm
-  2 3/8" 1/2"
-  45 Art. 1020

-  1/4"
-  5/16"
-  1/4" 1/4"
-  1/4"

-  1.5-2-2.5-3-4-5-6-8-10 mm
-  T10-T15-T20-T25-T27-T30-T40-T45-T50

















56
PCS

- | | | | | |
|---|--|---|---|---|
|  14 6-8-9-10-11-12-13-14
15-16-17-18-19-22 mm |  S2 | <ul style="list-style-type: none"> Art. 1110-1 3.2 x 75 mm Art. 1110-2 4.0 x 100 mm Art. 1110-3 5.0 x 100 mm Art. 1110-4 6.0 x 150 mm Art. 1110-5 8.0 x 150 mm |  4mm | <ul style="list-style-type: none"> 4 2-2.5-3-4 mm 3 PH00-2xPH0 2 PZ00-PZ0 6 T6-T7-T8-T9-T10-T15 3 1.5-2-2.5 mm 3 1.5-2-2.5 mm |
|  HICKORY
DIN 1041 Art. 2303 300 g |  S2 | Art. 1112-2 6.0 x 38 mm |  25 mm |  Art. 3180 |
|  HICKORY
Art. 2336 Ø 35 mm |  S2 | <ul style="list-style-type: none"> Art. 1115-1 PH1 Art. 1115-2 PH2 |  30° |  |
|  Art. 4320-1 |  S2 | Art. 1117-2 PH2 |  4 mm | |
|  Art. 4321 |  GS | Art. 2138 100-250 V | | |
|  Art. 4996 | | | | |



95
PCS

- | | | | | |
|---|----------------------|--|---|---|
|  DIN ISO 5746 | Art. 1281-180 180 mm |  Art. 1350-2 2 mm |  Art. 3305 300 mm |  50 |
|  DIN ISO 5749 | Art. 1282-160 160 mm | DIN 6450 Form C Art. 1350-3 3 mm |  Art. 3310 9 mm | |
|  DIN ISO 5745 | Art. 1285-200 200 mm | Art. 1350-4 4 mm |  12x Art. 3313 9 mm | |
|  | Art. 2221-250 250 mm | Art. 1350-5 5 mm |  Art. 3312 18 mm | |
|  | Art. 2225 240 mm | Art. 1350-6 6 mm |  15x Art. 3314 18 mm | |
| | | Art. 1350-8 8 mm |  | |
| | | Art. 1358-2 2 mm |  | |
| | | DIN 6458 | ergokraft Art. 2240 | |
| | | Art. 3380-18 18 mm | | |
| | | DIN 6451/53 Art. 3380-22 22 mm | | |

1/4" 1/2" 1/4" 5/16" **339**
PCS

Tool cabinet

Compact and solid workshop trolley with 7 ball bearing guided and individually locking drawers, equipped with 339 KRAFTWERK Junior quality tools. These tools are shake-proof embedded in 4 drawers with especially high density 2-coloured soft foam inserts (EVA).

Carro taller

Carro taller compacto y sólido con 7 cajones con guías de rodamientos de bola y cierre individual, equipado con 339 herramientas KRAFTWERK Junior. Las herramientas están colocadas en 4 cajones en bandejas EVA bi-colores de espuma de alta densidad.

Carro de ferramentas

Carro de ferramenta compacto e sólido, com 7 gavetas de tranca individual e guias de rolagentos, equipada com 339 ferramentas KRAFTWERK qualidade Junior. As ferramentas estão inseridas em 4 gavetas de espuma EVA de alta densidade e dupla tonalidade.





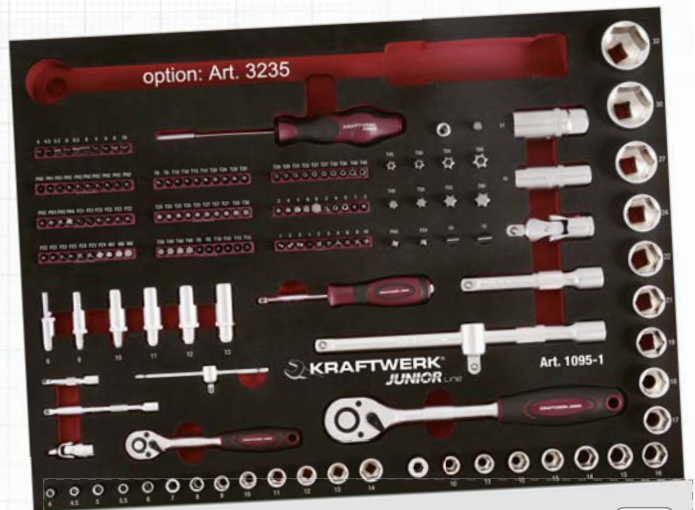



Art.		
1095	1907	7

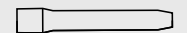

1/4"		13	4-4.5-5-5.5-6-7-8-9 10-11-12-13-14 mm	164 PCS
		6	6-8-10-11-12-13 mm	
			1/4" 1/4"	
			1/4" 1/4"	
		2	50 mm / 100 mm	
			115 mm	
			1/4"	
45			Art. 1000	
			1/4" 1/4"	
		6	4-4.5-5.5-6-6.5-8 mm	
		6	2xPH1-2xPH2-2xPH3	
		6	2xPZ1-2xPZ2-2xPZ3	
		24	2xT8-2xT10-2xT15-4xT20 5xT25-3xT27-3xT30-3xT40	
		15	TS10-2xTS15-2xTS20-3xTS25 2xTS27-3xTS30-2xTS40	
		5	3-4-5-6-8 mm	
		3	3-4-5 mm	
		4	No. 4-6-8-10	
		4	No. 1-2-3-4	
		3	No. 1-2-3	
		2	R1-R2	
		3	M5-M6-M8	
		3	6-8-10 mm	
			1/4" x 100 mm	
1/2"		16	10-11-12-13-14-15-16-17-18 19-21-22-24-27-30-32 mm	
		2	16 / 21 mm	
			1/2" 1/2"	
		2	125 mm / 250 mm	
			3/8" 1/2"	
45			Art. 1020	
			1/2" 5/16"	
5/16"		2	10/12 mm	
			PH4	
			PZ4	
		4	T45-T50-T55-T60	
		4	T45-T50-T55-T60	

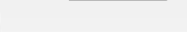

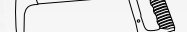
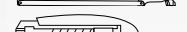
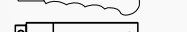
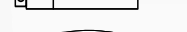







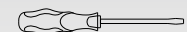
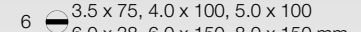
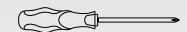
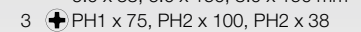

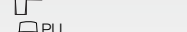
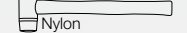

48
PCS

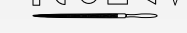
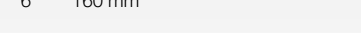
-  14 6-8-9-10-11-12-13-14-15-16-17-18-19-22 mm
-  2 18 / 22 mm
-  No.2 x 120 mm
-  2 x 115 mm 5 x 165 mm
-  6 3 x 125 mm 6 x 180 mm
-  4 x 150 mm 8 x 180 mm
-  12" x 300 mm
-  3 18 mm
-  10 18 mm
-  9 mm
-  10 9 mm

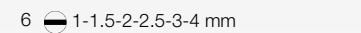
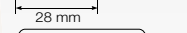
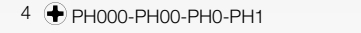
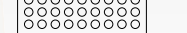
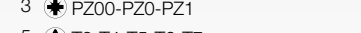
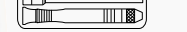
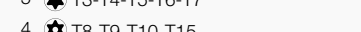

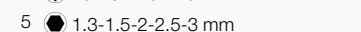
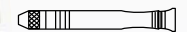

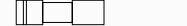







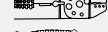

49
PCS

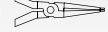
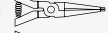
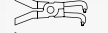
-  6  3.5 x 75, 4.0 x 100, 5.0 x 100
-  3  PH1 x 75, PH2 x 100, PH2 x 38
-   GS 110-250 V
-  300 g
-  PU 360 g 35 mm
-  Nylon 320 mm / No.2
-  6 160 mm
-  6  1-1.5-2-2.5-3-4 mm
-  4  PH000-PH00-PH0-PH1
-  3  PZ00-PZ0-PZ1
-  5  T3-T4-T5-T6-T7
-  4  T8-T9-T10-T15
-  5  1.3-1.5-2-2.5-3 mm
-  107 mm
-  105 mm
-  9 LED's

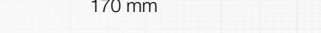

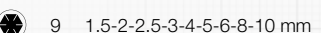
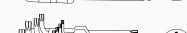
78
PCS

-  DIN ISO 5749 160 mm
-  DIN ISO 5746 180 mm
-  DIN ISO 5745 200 mm
-  250 mm
-  225 mm
-  185 mm
-  180 mm
-  180 mm
-  170 mm
-  170 mm
-  9  1.5-2-2.5-3-4-5-6-8-10 mm
-  9  T10-T15-T20-T25-T27-T30
-  T40-T45-T50
-  50

1/4" 1/2" 1/4" **266**
PCS

Tool cabinet Junior
equipped with EVA-foam inserts

Carro taller Junior
con herramientas y bandejas de espuma EVA standard

Carro de ferramentas Junior
com ferramentas colocadas em gavetas inseridas em espuma EVA standard



- | | | |
|--|----|---|
| | 14 | 3.5-4-4.5-5-5.5-6-7-8-9-10-11-12-13-14 mm |
| | 12 | 4-4.5-5-5.5-6-7-8-9-10-11-12-13 mm |
| | 3 | 4-5.5-6.5 mm |
| | 3 | PH 1-2-3 |
| | 3 | PZ 1-2-3 |
| | 8 | T8-T10-T15-T20-T25-T27-T30-T40 |
| | 6 | 3-4-5-6-7-8 mm |
| | | 1/4" 1/4" |
| | | 1/4" 1/4" |
| | 2 | 50 mm / 100 mm |
| | | 150 mm |
| | | 105 mm |
| | | 1/4" 1/4" |
| | | 1/4" 1/4" |

- | | | |
|--|----|------------|
| | 72 | Art. 3799 |
| | 60 | Art. 4000B |



- | | | |
|--|----|--|
| | 17 | 10-11-12-13-14-15-16-17-18
19-21-22-24-27-30-32-34 mm |
| | 9 | 10-13-14-15-16-17-18-19-22 mm |
| | | 1/2" 5/16" |
| | | 1/2" 1/2" |
| | 2 | 125 mm / 250 mm |
| | | 3/8" 1/2" |
| | 60 | Art. 4020B |

- | | | |
|--|---|------------------------------------|
| | 6 | 4-4.5-5.5-6-6.5-8 mm |
| | 4 | PH 1-2-3-4 |
| | 4 | PZ 1-2-3-4 |
| | 8 | T8-T10-T15-T20
T25-T27-T30-T40 |
| | 8 | T8-T10-T15-T20
T25-T27-T30-T40 |
| | 6 | 3-4-5-6-7-8 mm |
| | 6 | 2-2.5-3-4-5-6 mm |
| | 6 | 5/64"-3/32"-7/64"-1/8"-9/64"-5/32" |
| | 3 | No. 6-8-10 |
| | 4 | No. 1-2-3-4 |
| | 4 | No. 4-6-8-10 |



Art.		Art.	
1907-4921EVA	1907		7



ergokraft



44
PCS



DIN 3113

Art. 3505	5.5 mm	Art. 3511	11 mm	Art. 3517	17 mm	Art. 3524	23 mm
Art. 3506	6 mm	Art. 3512	12 mm	Art. 3518	18 mm	Art. 3527	24 mm
Art. 3507	7 mm	Art. 3513	13 mm	Art. 3519	19 mm	Art. 3530	27 mm
Art. 3508	8 mm	Art. 3514	14 mm	Art. 3520	20 mm	Art. 3531	30 mm
Art. 3509	9 mm	Art. 3515	15 mm	Art. 3521	21 mm	Art. 3532	32 mm
Art. 3510	10 mm	Art. 3516	16 mm	Art. 3522	22 mm		



DIN 2936 S2

Art. 3602
1.5-2-2.5-3-4-5-6-7-8-10 mm



ergokraft

DIN 3117 / ISO 6787

Art. 3572	150 mm / 6"
Art. 3573	200 mm / 8"



S2

Art. 3608
T10-T15-T20-T25-T27
T30-T40-T45-T50

ergokraft



18
PCS



DIN ISO 5746

Art. 3281-180 180 mm



DIN ISO 5749

Art. 3282-130 130 mm
Art. 3282-160 160 mm



DIN ISO 5745

Art. 3285-200 200 mm



DIN ISO 5745

Art. 3286-200 200 mm/45°



DIN ISO 5232

Art. 3289-160 160 mm

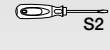

S2

Art. 4110-1	3 x 75 mm
Art. 4110-2	4 x 100 mm
Art. 4110-3	5 x 100 mm
Art. 4110-4	6 x 150 mm
Art. 4110-5	8 x 150 mm
Art. 4110-6	10 x 200 mm

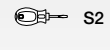

S2

Art. 4112-2 1.1 x 6 x 38 mm

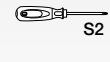

S2

Art. 4115-1 PH1 x 75 mm
Art. 4115-2 PH2 x 100 mm



S2

Art. 4117-2 PH2 x 38 mm



Art. 4128 1/4" x 100 mm

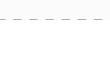

S2

Art. 2138 110-250 V

ergokraft



22
PCS



DIN 6450 Form C

Art. 1350-2	2 mm
Art. 1350-3	3 mm
Art. 1350-4	4 mm
Art. 1350-5	5 mm
Art. 1350-6	6 mm
Art. 1350-8	8 mm



DIN 6458

Art. 1355-2	2 mm
Art. 1355-3	3 mm
Art. 1355-4	4 mm
Art. 1355-5	5 mm
Art. 1355-6	6 mm



DIN 7250

Art. 1358-1	No. 1
Art. 1358-2	No. 2



DIN 6451/53

Art. 3380-18	18 mm
Art. 3380-22	22 mm

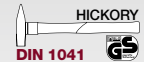

HICKORY

DIN 1041

Art. 2303
300 g

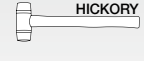

HICKORY

DIN 1041

Art. 2336
Ø 35 mm



Art. 4320-1 320 mm

DIN 7261



Art. 4320-2 320 mm

DIN 7261



Art. 4320-3 320 mm

DIN 7261



Art. 4320-4 320 mm

DIN 7261



Art. 4320-5 320 mm

DIN 7261

ergokraft



30
PCS



Art. 4321



Art. 3305

400 mm



ergokraft

Art. 3308-1



HSS-Bimetall

Art. 3316-24

300 mm



ergokraft

Art. 2240



Art. 3310

9 mm



12x

Art. 3313

9 mm



Art. 3312

18 mm

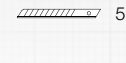

5x

Art. 3314

18 mm



Art. 5433

3-30 mm CU



Art. 5470

Ø 6-40 mm

Technical characteristics :

Especificaciones técnicas:

Especificações técnicas:

DIN

Manufactured according to DIN specifications
Fabricado según estándares DIN
 Fabricadas de acordo com normas DIN



Locking
Bloqueo
 Bloqueio

ISO

Manufactured according to ISO specifications
Fabricado según las normas ISO
 Fabricado de acordo com as normas ISO



Acrylonitrile-butadiene-styrene copolymere
Acrilonitrilo-Butadieno-Estireno
 Acrilonitrila Butadieno Estireno



TÜV-GS - Tested
TÜV-GS aprobado
 TÜV-GS aprovado



Aluminium
Aluminio
 Alumínio



Weight
Peso
 Peso



Chromium-molybdenum
Cromo-Molibdeno
 Cromo-Molibdênio



Dimensions
Dimensiones
 Dimensões



Chrome-vanadium
Cromo-vanadio
 Cromo-vanádio



inch sizes
Dimensiones en pulgadas
 Dimensões em polegadas



Torque
Grado de fuerza
 Binário



Ratchet mechanism, number of teeth per revolution
Mecanismo de trinquete, número de dientes por revolución
 Mecanismo de roquete, número de dentes por revolução



Stainless steel
Acero inoxidable
 Aço inoxidável



Ejection ratchet
Carraca con sistema de extracción
 Roquete com sistema de ejeção



S2 steel (chrome-silicium-manganese-molybdenum-vanadium-steel)
Acero S2 (acero cromo-silicio-manganeso-molibdeno-vanadio)
 Aço S2 (aço-cromio-silício-mangânesmolibdenio-vanádio)



























Magnetic
Magnético
 Magnético



KRAFTWERK Group

	KRAFTWERK Europe AG Mettenbachstrasse 23 CH-8617 Mönchaltorf	Tel.: +41 44 949 40 50 Fax: +41 44 948 11 58	E-Mail: info@kraftwerk.ch Web: www.kraftwerk.ch
  	KRAFTWERK Sàrl. 25, rue du Stade FR-67870 Bischoffsheim	Tel.: +33 388 48 64 50 Fax: +33 388 50 27 32	E-Mail: info@kraftwerk.fr Web: www.kraftwerk.eu
	KRAFTWERK Deutschland GmbH Lebacher Strasse 4 DE-66113 Saarbrücken	Tel.: +49 681 / 99 63 647 Fax: +49 681 / 99 63 646	E-Mail: info@de.kraftwerk.eu Web: www.kraftwerk.eu
	KRAFTWERK IBERICA S.L. C/De las Vacas, no. 6, oficina 5 ES-28341 Valdemoro (Madrid)	Tel.: +34 91 809 22 97 Fax: +34 91 809 49 33	E-Mail: kraftwerk@futurmet.es Web: www.kraftwerk.eu

KRAFTWERK Partners in Europe

  	A/S H. Sindby & Co. Bommerhavevej 41, Sletde DK-7100 Vejle	Tel.: +45 75 88 21 22 Fax: +45 75 88 22 40	E-Mail: sindby@sindby.dk Order: ordre@sindby.dk Web: www.sindby.dk
 	PROFIKRAFT TRADING, s.r.o. Bráfova 6 CZ-Bmo 616 00	Tel.: +420 541 249 260 Fax: +420 541 249 261	E-Mail: profikraft@profikraft.cz Web: www.profikraft.cz
	Tecniverca-Máquinas Ferramentas, Lda Estrada Municipal 1022, nº339 PT-2860-302 Pinhal de Areia-Moita	Tel.: +351 219 584 273 Fax: +351 219 577 133	E-Mail: tecniverca@tecniverca.pt Web: www.tecniverca.pt
	Van Heck - Interpieces N.V. Havendoklaan 14 BE-1804 Vilvoorde	Tel.: +32 2 255 84 50 Fax: +32 2 255 84 59	Web: www.vhjp.be
	Fource Hogebrikerweg 18 NL-3871 KN Hoevelaken	Tel.: +31 88 123 06 05 Fax: +31 88 123 06 51	E-Mail: tools@fource.nl Web: www.toolspecial.com
	Techno-Elit & Co. KG Hatzianesti 6 GR-18233 A.I.Rentis-Athen	Tel.: +30 210 4900064 Fax: +30 210 4900072	E-Mail: info@techno-elit.gr Web: www.techno-elit.gr
 	FLESCH EXPORT-IMPORT Fohlenweg 7 CH-9230 Flawil	Tel. RS: +38 162 587644 Tel. BIH: +38 765 197739	E-Mail: zivkofeschch@gmail.com Web: www.flesch-export-import.com
 	Hosendorfer Ges.m.b.H. Wodikgasse 7 AT-2353 Guntramsdorf/Wien	Tel.: +43 2236 53491 Fax: +43 2236 52347	E-Mail: office@hosendorfer.at Web: www.kraftwerk-hosendorfer.at
	Parts-Center NT Ruga Tirana p.n. KO-20000 Prizren	Tel.: +377 44 337 620; 646 920 Fax: +381 29 222 155	E-Mail: n.biri@parts-center.net Web: www.parts-center.net
	INTENSE s.r.l. Via Novara 1 IT-20063 Cernusco Sul Naviglio (MI)	Tel.: +39 02 921 8151 Fax: +39 02 921 04594	E-Mail: info@intense.it Web: www.kraftwerktools.it
	Neil Oxborrow Kraftwerk Tools UK 3 Playfield Road, Capel St. Mary GB- IP9 2HP Ipswich, Suffolk	Tel.: +44 7956 411394	E-Mail: neil@kraftwerktoolsonline.co.uk Web: www.kraftwerktools.co.uk
	Logey ehf heildverslun Vesturvör 7 IS-200 Kópavogur	Tel.: +354 511 2055 Fax: +354 511 2056	E-Mail: logey@logey.is Web: www.logey.is
	Vekra LCC Tehnika 3 EE-75501 Saku, Harjumaa	Tel.: +372 677 9665	E-Mail: info@vekra.ee Web: www.vekra.ee
	Magnetic Services Ltd. Vjal Sir Paul Boffa MT-9023 Paola	Tel.: +356 21676529 Fax: +356 21802161	E-Mail: info@magneticservices.com.mt Web: www.magneticservices.com.mt
	SamZ s.r.o. Mierova 183 SK- 82105 Bratislava	Tel.: +421 903 701 201	E-Mail: m.zgebura@samz.sk Web: www.kraftwerk.sk
	REBIOP, s.r.o. SNP 51/2298 SK- 95301 Zlaté Moravce	Tel.: +421 37 630 6303 Fax: +421 37 630 6301	E-Mail: homola@rebiop.sk Web: www.rebiop.sk
	Swedish Levant Trading (CYPRUS) Ltd. 154, Giannou Kranidioti CY-2235 Latsia	Tel.: +357 22 574 041 Fax: +357 22 574 043	E-Mail: info@swedishlevant.com Web: www.swedishlevant.com
	Oldi & Co. Lubanas Iela 49 LV-1073 Riga	Tel.: +371 7248 907 Fax: +371 7248 906	E-Mail: oldi@oldi.net Web: www.oldi.net
	Dimas Plast Ltd. 63, Shipchenski prohod Blvd. BG- 1574 Sofia	Tel.: +359 2 978 31 71 Fax: +359 2 978 31 71	E-Mail: info@dimasplast.com Web: www.carchemie.com

KRAFTWERK Partners in Africa

	Kaufmann 65, Bd Mly Ismail MA-20290 Casablanca	Tel.: +212 522 24 85 85 Fax: +212 522 24 82 86	E-Mail: faouzi.khelifi@kaufmann.ma Web: www.kaufmann.ma
	Windhoek Tool Centre CC P.O. Box 9660 NA-Windhoek	Tel.: +264 61 263 251 Fax: +264 61 216 421	E-Mail: whktools@mweb.com.na

KRAFTWERK Partners in Middle East

	Shimron Technologies P.O. Box 86 110 Haerez Street IL-90901 Givon Hadasha	Tel.: +972 2 536 24 51	E-Mail: shimrontech@gmail.com Web: www.shimrontech.co.il
	JOY Middle East LLC Al Quoz 3, Sheikh Zayed Road Dubai	Tel.: +971 4 380 53 55	E-Mail: info@joymellc.com Web: www.joymellc.com
	Power Machinery Co. Pasha Plaza, Floor No. 6 Thaliya Street beside Bughsan Hospital 21431 Jeddah SA Saudi Arabia	Tel.: +966 12 66 58 011 Fax: +966 12 65 49 384	E-Mail: matthias@aka.com.sa Web: www.aka.com.sa



Your specialized dealer: | *Su distribuidor especializado* : |
Agente autorizado KRAFTWERK:



Contacto tel. 00 351 93 737 81 80
geral@dimarx.pt - www.dimarx.pt