

# Down Lite HIGH POWER

Cat. No. DL/HP

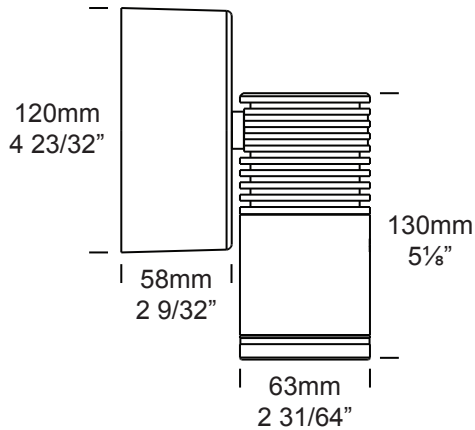

**PURE LED**  
Pure Performance

The Down Lite High Power is suitable for mounting on timber, masonry, stone, etc, non-adjustable for one way wall washing, can be mounted with the lamp directed up or down. Water resistant with a 120mm diameter mounting base, complete with stainless steel screws.

This luminaire is machined from solid aluminium with a UV stable "E" powder coated finish. It features a clear, tempered, flush glass lens and high temperature silicon gaskets.

The Hunza HIGH POWER system uses Cree MT-G 2 chips for maximum performance and long life. Power supply options include a choice of a 120/240 volt (Retro) driver or an external remote (series connection) driver. The HIGH POWER system incorporates Hunza's Plug-and-Play system for easy replacement of the LED engine. Four beam angles, and a choice of 3000K, 4000K and 5000K colour temperatures are available.

## Ordering Information

Luminaire	Driver mA	Beam Angle	Colour Temp	Accessories	Material/Finish
DL/HP	S - Series R - 110 or 240v Retro	15 - 15° TIR Lens 25 - 25° TIR Lens 38 - 38° Reflector 60 - 60° Reflector	3 - 3000K 4 - 4000K 5 - 5000K	GG - Glare Guard STEPF - Frosted Lens HCL - Hex Cell Louvre Kit	BK - Black BZ - Bronze STAR - Silver Star WH - White

Ordering Example: DL/HP S 15 3 GG BK

**HUNZA**™ PURE  
OUTDOOR  
LIGHTING

HUNZA FACTORY  
130 Felton Mathew Ave  
Saint Johns  
Auckland 1072  
New Zealand

Ph: 64-9-528 9471  
Fax: 64-9-528 9361  
hunza@hunza.co.nz  
www.hunza.co.nz

INTERNATIONAL CONTACTS:  
[www.hunza.co.nz/contacts.php](http://www.hunza.co.nz/contacts.php)

Specifications may change without notice.  
Manufactured in New Zealand.  
© 2014 Hunza Holdings Ltd.

## Luminaire Construction

### CNC machined from:

High corrosion resistant 63.5mm (2½") x 10mm (25/64") aluminium.

HP body - solid aluminium 63.5mm (2½") rod with chromate substrate and high UV resistant polyester "E" powder coat colours Black, Bronze, Silver Star, White.

### Luminaire Weight

Alum .870kg (1lb 14oz)

## Luminaire Features

### Lens

10mm (3/8") extra clear low iron flush fit shatter resistant glass. Lifetime Warranty.

### Gasket

Silicone, iron impregnated 220°C (428°F)

### Accessories

Frosted Lens (Cat. STEPF)  
Glare Guard (Cat. GG)  
Hex Cell Louvre Kit (Cat. HCL)

### Mounting

A mounting plate is fixed to the wall using two screws and the luminaire is fitted to the mounting plate.

## Technical Information

### Standards

AS/NZS 61046  
IP56/IP66 UL 1598

### LED

Cree MTG 2 Plug and Play, field replaceable LED board.

**Lumen Output:** 1000lm at 2080mA

**Lumens Per watt:** 83 minimum

**CRI Warm White (3000k):** 85+

**Colour Temp:** 3000K, 4000K or 5000K

### Power Supply

#### External (Series) Driver (per head)

Constant current driver

Output: 6vdc at 2080mA maximum

#### Retro 110/240 Volt Driver Hunza™

Retro Driver

Input: 90-305vac, 2080mA

0-10 volt dimming

## Reflector Beam Angles

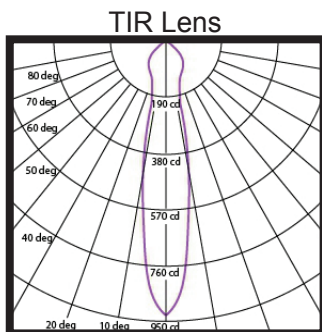

15° Angle  
3000 K

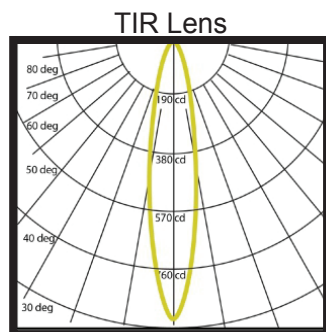

25° Angle  
3000 K

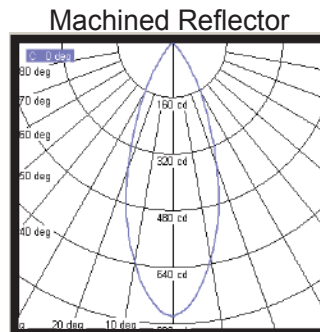

38° Angle  
3000 K

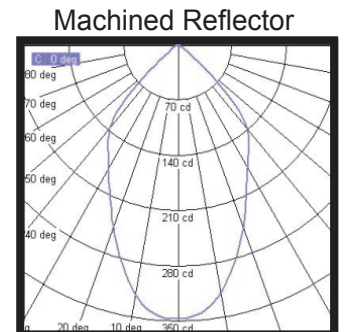

60° Angle  
3000 K

**HUNZA**™ PURE  
OUTDOOR  
LIGHTING

HUNZA FACTORY  
130 Felton Mathew Ave  
Saint Johns  
Auckland 1072  
New Zealand

Ph: 64-9-528 9471  
Fax: 64-9-528 9361  
hunza@hunza.co.nz  
www.hunza.co.nz

INTERNATIONAL CONTACTS:  
[www.hunza.co.nz/contacts.php](http://www.hunza.co.nz/contacts.php)

Specifications may change without notice.  
Manufactured in New Zealand.  
© 2014 Hunza Holdings Ltd.