

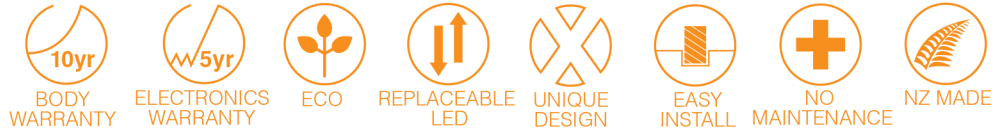

CONFIGURE THIS PRODUCT



M2 or M4

Power	Material	Flange	Lens Cover	Beam	Colour	Driver
2 2 Watt 4 4 Watt	B Brass	HNG Hanging Light	C clear F frosted H hexcell	8 8° TIR * 12 12° TIR # 26 26° * # 36 36° # 74 74° * # 15 + 40 oval TIR *	R red * G green * B blue * A amber * WWW warm white 2700°K WW warm white 3000°K NW neutral white 4000°K CW cool white 5000°K	I integral R remote

* Only available as a M2
Only available as a M4

SPECIFICATIONS

Power	2 Watt
Ingress Protection Rating	IP68
Cable	H05RN - F 1m included
Material	Brass
Hexcell Baffle Insert	Hexcell beam orientation available
Lens Cover	Clear, Frosted Glass
Removable Light Engine	Pin mounted 2W Cree White XTE Chip
Colours	Warm White 2700°K, 3000°K Neutral White 4000°K Cool White 5000°K Red, Green, Blue, Amber
CRI	Ra 82 (90+ CRI Option)
Efficacy	75 lm/W
Optic Degrees	8°, 26°, 74°, Oval,
Input	700mA constant current (Remote) 12V AC (Integral)
Warranty	Electronics Warranty 5 years Body Warranty 5 years/10 years
LEDshield	LED Bypass Shunt



REMOTE DRIVER WIRED IN SERIES

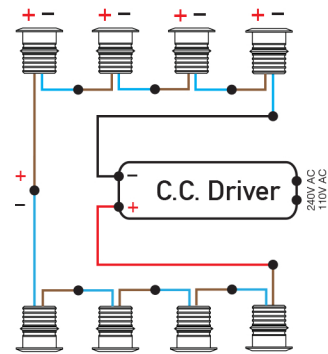

INTEGRAL DRIVER + TRANSFORMER

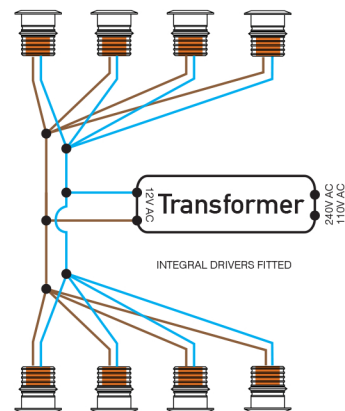

INSTALLATION INSTRUCTIONS

Connect remote driver versions in series.
Connect integral driver versions in parallel.
IP68 connector recommended. Never switch the output of a constant current driver. Driver must be switched off when connecting LED's to prevent damage.

ACCESSORIES: PVC Canister

HANGING LIGHT DIMENSIONS

