

# Pool Lite HIGH POWER

Cat. No. POOL/HP

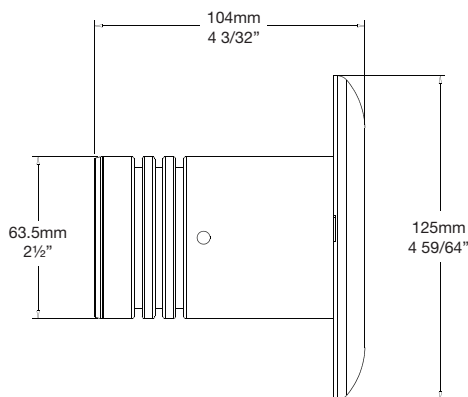

**PURE LED**  
Pure Performance

The Pool Lite HIGH POWER is electro polished for extra corrosion protection and is held in the PVC canister by two 'O' rings. There are no mounting screws in the flange to spoil the aesthetics of this luminaire. Up to 600mm (2 ft) of cable can be coiled up inside the mounting canister enabling the luminaire to be removed for lamp changing above the water line. Supplied with 6 metres (18 ft) of submersible cable. Longer cable available on request. The Pool Lite PVC Canister can be ordered separately on request.

The Hunza HIGH POWER system uses Cree MT-G 2 chips for maximum performance and long life. Power supply is an external remote driver. The HIGH POWER system incorporates Hunza's Plug-and-Play system for easy replacement of the LED engine. Four beam angles, and a choice of 2700K, 3000K or 4000K colour temperatures are available.

## Pool Lite PVC Canister

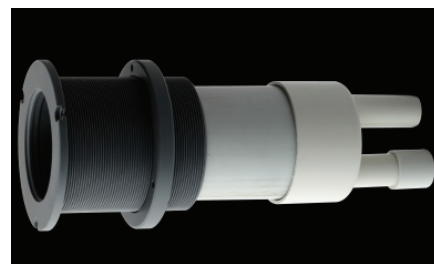
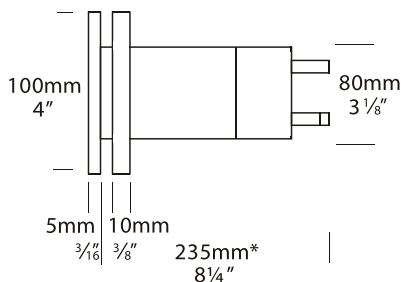

## Ordering Information

Luminaire	Driver mA	Beam Angle	Colour Temp	Accessories	Material/Finish
POOL/HP	S - Series SR - Series Remote Driver	15 - 15° TIR Lens 25 - 25° TIR Lens 38 - 38° TIR Lens 60 - 60° TIR Lens	2 - 2700K 3 - 3000K 4 - 4000K 39 - 3000K (90+ CRI)	HCL - Hex Cell Louvre STEPF - Frosted Lens CJK150 - Cable Joint Kit PLCAN - Pool Lite Canister	SS - 316 Stainless Steel

Ordering Example: POOL/HP S 15 3 HCL SS

**HUNZA**<sup>TM</sup> PURE OUTDOOR LIGHTING

HUNZA FACTORY  
130 Felton Mathew Ave  
Saint Johns  
Auckland 1072  
New Zealand

Ph: 64-9-528 9471  
Fax: 64-9-528 9361  
hunza@hunza.co.nz  
www.hunza.co.nz

INTERNATIONAL CONTACTS:  
[www.hunza.co.nz/contacts.php](http://www.hunza.co.nz/contacts.php)

Specifications may change without notice.  
Manufactured in New Zealand.  
© 2015 Hunza Holdings Ltd.

## Luminaire Construction

### CNC machined from:

Body: 316 Stainless Steel 9mm (1/3").

Endcap: Solid 316 Stainless Steel 63.5mm (2 1/2") rod, electro polished to increase corrosion protection by up to 33%.

### Canister:

CNC machined from engineering grade PVC with moulded PVC end cap which has 20mm (3/4") conduit entry for electrical connections.

### Luminaire Weight

SS 1.885kg (4lbs 2oz)

## Luminaire Features

### Lens

10mm (3/8") extra clear low iron flush fit shatter resistant glass. Lifetime Warranty.

### Gasket

Silicone, iron impregnated 220°C (428°F)

### Accessories

Cable Joint Kit (Cat. CJK150)  
Frosted Lens (Cat. STEP F)  
Hex Cell Louvre (Cat. HCL)  
Pool Lite Canister (Cat. PLCAN)

### Mounting

The PVC mounting canister is suitable for installation into three different types of pool wall:  
1) fibreglass pools, 2) existing concrete pools, 3) new concrete pools.

*WARNING - Out of balance pool chemicals may cause the luminaire to corrode at a rapid rate. In salt water an increase in water temperature of 10 degrees will double the corrosion factor. 316 stainless steel is suitable for situations of up to 1000 parts per million of chloride. Where an automatic chlorinator is employed an excess amount of chlorine may be produced. The Hunza Pool Lite is electro polished to increase corrosion protection by up to 33%.*

## Technical Information

### Standards

IP68  
AS/NZS 61046  
Non-UL

### LED

Cree MTG 2 Plug and Play, field replaceable LED board.

**Lumen Output:** 1000 @ 2080mA

**Lumens Per watt:** 83 minimum

**CRI Warm White (3000k):** 85+  
**Colour Temp:** 2700K, 3000K or 4000K

**High CRI Option (3000K):** 90+  
(lumen output decreases by 15%)

### Power Supply

#### Remote Driver:

Input: 90-305 volts

Output: 2080mA constant current  
UL & cUL class 2 output

0-10V dimming.

The driver supplied separately.

Series version also available.

## Beam Angles

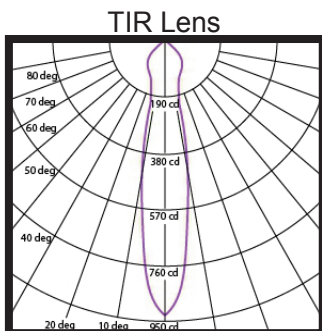

15° Angle  
3000 K

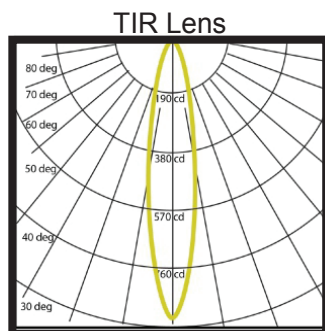

25° Angle  
3000 K

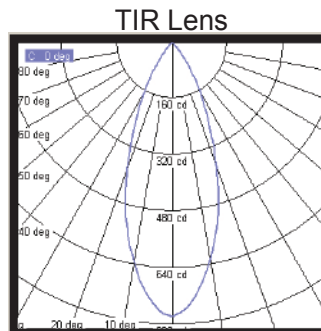

38° Angle  
3000 K

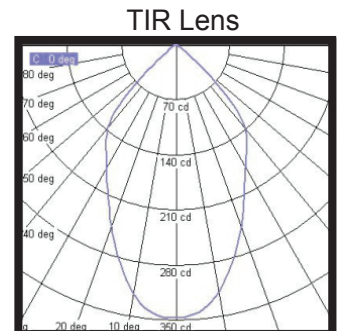

60° Angle  
3000 K

**HUNZA**™ PURE  
OUTDOOR  
LIGHTING

HUNZA FACTORY  
130 Felton Mathew Ave  
Saint Johns  
Auckland 1072  
New Zealand

Ph: 64-9-528 9471  
Fax: 64-9-528 9361  
hunza@hunza.co.nz  
www.hunza.co.nz

INTERNATIONAL CONTACTS:  
[www.hunza.co.nz/contacts.php](http://www.hunza.co.nz/contacts.php)

Specifications may change without notice.  
Manufactured in New Zealand.  
© 2015 Hunza Holdings Ltd.