



arteferro

# GONZATO DESIGN

FINE WROUGHT  
IRON FORGINGS

L'attenta ricerca tipologica che sta alla base di questi prodotti dal design rivoluzionario li qualifica tra le più moderne e riuscite interpretazioni dell'antica e nobile arte del ferro battuto.

The revolutionary design of these products, founded on careful typological research, makes them among the most modern and successful interpretations of the ancient and noble art of wrought iron.



Pannello pre-assemblato (Art. 236/1)  
Pre-assembled panel (Art. 236/1)

**Gonzato Design** è la linea di prodotti Arteferro caratterizzata da uno stile innovativo. I motivi classici del ferro battuto si fondono e dialogano con le geometrie moderne dando vita ad un insieme unico che parla di passato e futuro. Le linee in stile Art Nouveau di inizio '900 sono mediate con una sensibilità contemporanea che razionalizza lo spazio e lo rende elegante e preciso.

Tra gli articoli Gonzato Design anche i **pannelli pre-assemblati** che, pronti per l'installazione, sono pensati per facilitare il lavoro dell'artigiano: basta unirli tra loro o accoppiarli a dei semplici paletti di ferro liscio per realizzare la propria composizione. Una soluzione di design e pratica che consente un notevole risparmio di tempo e denaro. Come tutti i prodotti Arteferro anche i pannelli pre-assemblati possono esser prodotti anche **anche su misura**.

The **Gonzato Design** product line by Arteferro is set apart by its innovative style. The classical wrought iron motifs interact with modern geometry, creating a unique combination of past and future. The lines, inspired by the Art Nouveau style of the early 1900s, are mediated with a contemporary awareness, rationalising space and making it elegant and precise.

The Gonzato Design range also includes **preassembled panels**, ready for installation, designed to facilitate the work of the craftsman: just join them together or connect them to simple smooth iron posts to make your own arrangement. A practical design solution that allows for considerable savings in terms of both time and money. Like all Arteferro products, the pre-assembled panels can also be custom-made.



Copyright © 2016 Ind.i.a. spa. Tutti i diritti riservati. Domanda di marchio, design o brevetto depositata/registrazione o brevetto rilasciato in uno o più paesi. Per ulteriori informazioni, non esitate a contattarci a [info@arteferro.com](mailto:info@arteferro.com).  
Copyright © 2016 Ind.i.a. spa. All rights reserved. Trademark, design or patent application pending/registration or patent granted in one or more countries. For additional information, please contact us at [info@arteferro.com](mailto:info@arteferro.com).

# Gonzato Design tra Fantasia, rigore e innovazione. Gonzato Design: creativity, precision and innovation.

La quarantennale esperienza degli Architetti Bruno Gonzato e Stefania Buccio e le sempre maggiori possibilità tecniche di lavorazione del ferro hanno permesso di maturare la consapevolezza di come questo materiale può essere sagomato non soltanto in forme classiche e tradizionali ma anche in sempre più moderne ed originali soluzioni.

Architects Bruno Gonzato and Stefania Buccio bring their forty years' experience together with new technical ironworking possibilities, allowing us to gain an awareness of how this material can be shaped not only in classical and traditional forms, but also in increasingly modern and original solutions.

La linea di prodotti Gonzato Design by Arterferro è stata ampliata con tanti nuovi articoli e raggruppata in famiglie: Geometric, Revolution, New Waves e tante altre tutte da scoprire!

*The Gonzato Design product line from Arterferro has been extended to include many new articles, and grouped into families: Geometric, Revolution, New Waves and many more to discover!*

NEW

## Perché scegliere i prodotti Gonzato Design? Why choose the Gonzato Design products?



Design esclusivo  
e brevettato  
Exclusive and  
patented design



Saldature e lavorazioni  
di alta qualità  
High-quality welding  
and workmanship



Installazione più facile  
e più veloce rispetto  
ai classici paletti  
Easier and faster  
installation than  
classic posts



Alto valore aggiunto al  
tuo manufatto finale  
High added value to  
your end product



Eccellente rapporto  
qualità-prezzo  
Excellent value for  
money



Ideale per  
installazioni in  
contesti moderni  
Ideal for  
installation in  
modern contexts





Con più di 20 società, sparse in tutto il mondo, Gonzato Group è leader nella produzione e distribuzione di semilavorati e sistemi modulari in metallo per l'edilizia e l'architettura. I suoi prodotti, distribuiti in 136 paesi, sono stati scelti per proteggere ed adornare alcuni dei più importanti edifici e complessi mondiali, tra i quali il palazzo di Giustizia ed il Colosseo di Roma, il parco Terenure di Dublino, Disneyland a Parigi e molte altre prestigiose ville e residenze da Hollywood a San Pietroburgo, passando per Londra, Pechino e Saint Tropez.

With more than 20 companies spread throughout the world, Gonzato Group is the leader in production of semi-finished products and modular systems in metal for construction and architecture. Its products, distributed in 136 countries, have been chosen to protect and adorn some of the most important buildings in the world, including: the palace of Justice and the Colosseum in Rome, the park Terenure in Dublin, Disneyland in Paris, and many other prestigious villas and residences in St Petersburg, passing through London, Beijing, and Saint Tropez.



### Un'azienda rivolta al futuro.

Dal 1971 siamo leader mondiali nella produzione e commercializzazione di semilavorati ornamentali per l'architettura. Tutti i prodotti sono frutto di studi attenti ed appassionati da parte di professionisti specializzati che conoscono il settore meglio di chiunque altro. Infatti è grazie alla attività del Gruppo che la produzione nel settore ha potuto svilupparsi tecnologicamente e progettualmente fino a diventare quel che è oggi.

L'esperienza maturata in oltre 40 anni di ferro battuto, ha consentito di sviluppare un altrettanto approfondita conoscenza dell'acciaio inox e dei suoi utilizzi nella recinzione. IAM Design, propone soluzioni più tecniche e stilizzate, mentre i manufatti in ferro battuto di Arteferro hanno caratteristiche di maggiore varietà ornamentale ma entrambe le linee di prodotti assolvono sempre a quelle stesse esigenze di protezione, sostegno e decorazione che ben conosciamo da sempre.

Nei cataloghi del Gruppo sono presenti oltre 32.000 manufatti per recinzioni ed arredamento, sempre pronti all'uso ed alla consegna. Grazie a questa esperienza pluridecennale che coinvolge tutta la filiera dalla produzione siderurgica, al design dei prodotti, alla loro realizzazione, all'installazione, siamo anche gli unici al mondo capaci di ideare con architetti e sviluppatori oltre che di realizzare ovunque grandi opere, forti del know how e della praticità dei nostri progettisti e operatori.

### A company looking towards the future.

Since 1971, we are world leader in the production and sale of ornamental components for the building industry and architecture. All our products are the result of careful and passionate research by qualified experts that know the field better than anyone else. In fact, it is thanks to the Group's work if the production of metal elements for architecture and constructions has been able to grow in terms of technology and project management to become what it is now.

The experience acquired in over 40 years of work in the field of wrought iron allowed us to develop in the last 15 years the same deep knowledge in the field of stainless steel and of its fencing applications. As a matter of fact, our IAM Design line, while being more technical and stylized compared to the Arteferro components, meets the same needs of safety, support and decoration that we have always well known.

In the Group's catalogues you will find more than 30.000 fencing and furniture components always ready to use and ready to be dispatched. Thanks to our long experience, that involves all the production and supply chain from product design to manufacturing, to the installation support, we are the sole company in the world who is able to realize and install anywhere big fencing structures, relying upon our know how and the practical sense of our designers and members of our team.

#### Leader di mercato

- leadership nei 5 continenti
- presenza in 136 stati
- gamma di oltre 32.000 articoli

#### Certificazioni

- ISO 9001 - Gestione della Qualità
- ISO 14001 - Gestione Ambientale

## Una realtà in continua crescita.

- Più di 20 aziende in 5 continenti con headquarter in Italia
- 4 stabilimenti produttivi
- 64.000 m<sup>2</sup> coperti
- Oltre 700 tra dipendenti e collaboratori
- 4.100 ton /mese spedite
- 40 milioni di semilavorati venduti mediamente in un anno
- Oltre 2000 clienti grossisti in 136 Stati nel mondo;
- Oltre 32.000 articoli diversi a stock

#### Leader in the market

- leadership in the 5 continents
- presence in 136 countries
- variety of more than 32.000 articles

#### Certifications

- ISO 9001 - Quality management
- ISO 14001 - Environmental management

## A constantly growing reality.

- more than 20 companies in 5 continents with the headquarter in Italy
- 4 production factories
- 64.000 m<sup>2</sup> indoor
- more than 700 employees and contributors
- 4.100 ton/month shipped
- 40 millions of semifinished sold on average every year
- more than 2.000 wholesaler customers in 136 countries of the world
- more than 32.000 different articles on stock.



## I nostri marchi Our brands



La gamma di prodotti Arteferro comprende oltre 32.000 elementi semilavorati ornamentali in ferro battuto, ottone e alluminio: barre battute, paletti forgiati, pannelli preassemblati, foglie, fiori, pigne, rosoni, ricci, cerchi ed altri elementi decorativi, oltre ad una ricca serie di complementi d'arredo. Sarà compito del fabbro assemblarli in oggetti finiti come parapetti, recinzioni o qualsiasi altra creazione gli suggerisca la sua creatività.

The range of Arteferro products includes over 32,000 semi-finished ornamental items in wrought iron, brass and aluminium: hollow bars, forged posts, pre-assembled panels, leaves, flowers, pine cones, medallions, curls, circles, and other decorative items, as well as a wide selection of furnishings. Blacksmiths assemble them into finished objects such as railings, fences or any other creation your mind can make up.



La gamma di prodotti IAM Design comprende oltre 2.500 elementi componibili e modulari in acciaio inox per realizzare parapetti, recinzioni, pensiline, scale ed altri elementi strutturali, per interni ed esterni. Il design moderno e lineare dei vari elementi consente una facile e veloce installazione e soddisfa le esigenze di architetti, progettisti e professionisti adattandosi perfettamente ad ogni tipo di ambiente.

The range of IAM Design products includes over 2,500 combinable, modular stainless steel elements, to make railings, fences, porches, stairs and other interior and exterior structural elements. The modern, linear design of the various elements allows for easy and quick installation and meets the needs of architects, designers and professionals, adapting perfectly to any type of environment.



Nuova CO.GE.ME. S.p.A. nasce nel 1970 con una missione: entrare nella siderurgia di qualità da protagonisti, producendo acciaio che artigiani e industriali trovasse perfetto per le proprie esigenze produttive.

Nuova CO.GE.ME. S.p.A. was founded in 1970 with a mission: to become a leader in the steel industry, producing steel to perfectly suit the production needs of both craftsmen and industry.

### I nostri servizi "chiavi in mano"



Gonzato Contract è la divisione di Ind.i.a. che si occupa di forniture speciali, in ferro battuto, in acciaio inox o in qualsiasi altro metallo, per prestigiose proprietà private, edifici pubblici, alberghi, spazi comunitari e per ogni tipo di commissione che richieda un approccio custom made, dalla progettazione all'installazione. Affiancando il committente durante tutto il percorso, dai primi passi fino al lavoro finito, Gonzato Contract è partner ideale per ogni progetto e si pone nei confronti del cliente come unica responsabile della qualità del proprio prodotto e del servizio offerto.

### Our "Turnkey" service

Gonzato Contract is the division of Ind.i.a. dealing with special supplies in wrought iron, stainless steel or any other metal, for prestigious private homes, public buildings, hotels, community spaces and for all types of commission that require a custom-made approach, from design to installation. Working alongside the client throughout the process, from the first steps to the finished work, Gonzato Contract is the ideal partner for any project, taking sole responsibility for product quality and the service offered.



## Produzione

Dall'ideazione all'installazione, ci occupiamo di ogni aspetto del prodotto.

I nostri articoli, rispetto alla gran parte dei prodotti che si trovano sul mercato, sono realizzati nei nostri centri produttivi in Italia ed Europa, sottostando a test qualitativi che ci consentono di conoscere la vita di ogni pezzo, dalla sua nascita alla sua consegna.

Inoltre, siamo l'unica azienda del settore che può vantare una capacità produttiva in grado di soddisfare ogni richiesta speciale entro tempi di stretta produzione.

## Production

From concept to installation, we take care of every aspect of the product.

Our items, unlike most other products on the market, are manufactured in our production centres in Italy and Europe and subjected to quality testing; we know the entire life cycle of each piece, from creation to delivery.

Furthermore, we are the only company in the industry that can boast a production capacity able to meet any special request with such short production timelines.

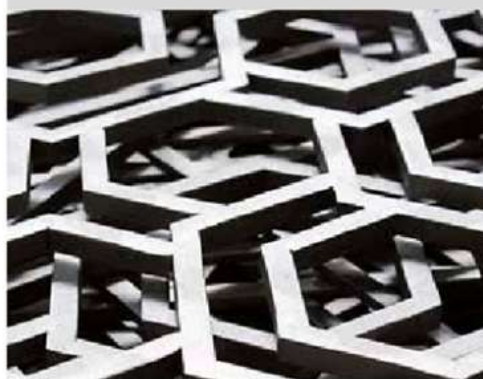

# DAI VALORE ALLE TUE OPERE ADDING VALUE TO YOUR PROJECT



Art. Nr	€/Unit.	Nr.	€ Tot.
105/1/C	4,27	10	42,70
105/2/C	3,43	10	34,30

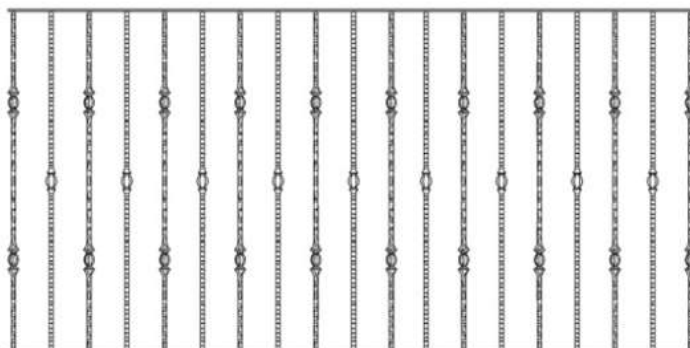

Costo materiale  
Material cost **77,00 €**

Valore percepito  
Perceived value **154,00 €**



Due metri di parapetto, realizzato con **prodotti ordinari**.  
Two-meter-long railing, realized with ordinary products.



Art. Nr	€/Unit.	Nr.	€ Tot.
GD216/3	61,90	1	61,90
1368/4	1,00	14	14,00



Costo materiale  
Material cost **75,90 €**

Valore percepito  
Perceived value **228,00 €**

**GUADAGNO  
EARNING + 98%** 

I pannelli Gonzato Design ti permettono di ottenere un risultato estetico notevolmente superiore rispetto ai soliti manufatti in ferro battuto. Quante recinzioni o scale risultano banali stilisticamente solamente perchè non si è avuto la capacità e di aggiungere dei prodotti che danno giusto valore estetico? Ora con i pannelli Gonzato Design puoi osare stilisticamente senza spendere una fortuna. Il risultato finale sarà un parapetto o una cancellata dallo stile unico e moderno il cui valore artistico è ben superiore alla somma investita.

Gonzato Design panels offer a far superior aesthetic result than is typically achieved with other iron products. How many fences or stairways are stylistically uninteresting simply because there were no suitable products available? Now with Gonzato Design panels you can be stylistically daring without spending a fortune. The end result will be a railing or fence with a modern and unique style, whose artistic value is far greater than the amount invested.



Art. Nr	€/Unit.	Nr.	€ Tot.
GD231/1	58,34	1	58,34
1368/4	1,00	14	14,00

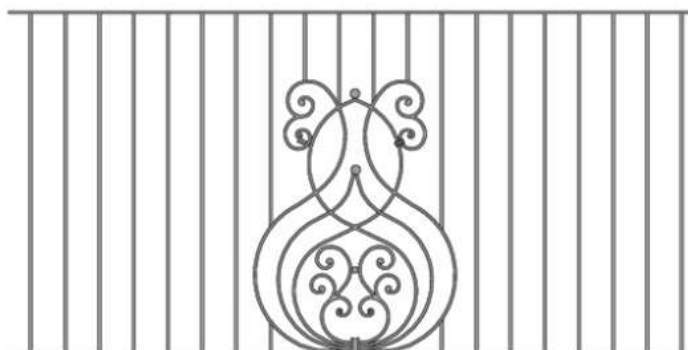

Costo materiale  
Material cost **72,34 €**

Valore percepito  
Perceived value **217,02 €**

**GUADAGNO**  
**EARNING + 91%** 😊



Art. Nr	€/Unit.	Nr.	€ Tot.
GD302/1	76,88	1	76,88
1368/9	0,70	12	8,40

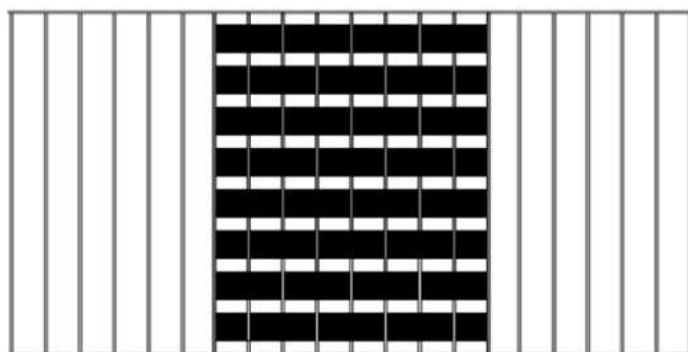

Costo materiale  
Material cost **85,28 €**

Valore percepito  
Perceived value **255,85 €**

**GUADAGNO**  
**EARNING + 120%** 😊



## Innovazione

Il cliente e le sue esigenze sono il fulcro della nostra attenzione. Per questo motivo un team di designers ed ingegneri lavora quotidianamente all'ideazione di nuovi prodotti che soddisfino sempre più la necessità di bellezza in armonia con le esigenze tecniche oggettive.

Siamo costantemente alla ricerca di materiali diversi da accompagnare alle nostre linee per esaltarne le caratteristiche strutturali ed estetiche (legno, vetro e molti altri ancora).

Studiamo il design dei nostri prodotti in modo che possano essere al passo con i tempi. Crediamo che i prodotti debbano essere semplici da assemblare e da integrare con gli altri elementi architettonici in modo da potersi adattare all'ambiente in cui vengono installati con la massima flessibilità.

## Innovation

The customer and their needs are the primary focus of our attention. For this reason, a team of designers and engineers work daily designing new products, combining our aesthetic standards with current technical requirements.

We are constantly looking at different materials to use in our lines to enhance their structural and aesthetic characteristics (wood, glass and many more).

We study the design of our products to stay in step with the times. We believe that our products should be easy to assemble and integrate with other architectural elements, in order to adapt to the environment in which they are installed with maximum flexibility.

# Assistenza e servizio: la nostra forza Service and support: our strength



### Ordinato, consegnato!

Con le nostre filiali sparse in tutti i continenti, disponiamo del più grande stock mondiale di articoli del settore e, grazie ai nostri accordi con i più importanti spedizionieri, possiamo garantire consegne celeri in qualsiasi paese. Inoltre, grazie al nostro portale *Ind i.a. web*, i clienti possono rimanere aggiornati sulle scorte di magazzino e sui dettagli dei propri ordini.

### Ordered, delivered!

With branches spread across the continents, we have the largest stock of articles in the sector worldwide, and, thanks to our agreements with major carriers, we guarantee prompt delivery in any country. Also, thanks to our *Ind i.a. web* portal, customers can stay up to date on stock and the details of their orders.



### Miglior prezzo

Le grosse quantità che trattiamo ci consentono economie di scala sulla materia prima. Inoltre, il prezzo dei nostri listini, è il prezzo del produttore, non soggetto a ricariche dovute alla presenza di intermediari. È un prezzo di fabbrica!

### Best Price

The large volumes that we handle allow us economies of scale on raw materials. Also, the prices on our list are direct from the manufacturer, not subject to increases due to the presence of middlemen. These are factory prices!



### Progettazione su misura

I nostri tecnici sono a disposizione per consulenze specializzate e sono in grado di sviluppare progetti su misura. Con la nostra divisione *Gonzato Contract* possiamo fornire anche soluzioni chiavi in mano, dalla progettazione all'installazione.

### Bespoke design

Our technicians are available for specialised consultation, and are able to develop custom projects. With our *Gonzato Contract* division we can also provide turnkey solutions, from design to installation.



### Prodotti per l'installazione, finitura e manutenzione

Oltre ai nostri articoli, forniamo anche i prodotti e gli strumenti per la loro installazione, finitura e manutenzione: attrezzi per il montaggio e il trattamento, vernici e patine per rifinire ed impreziosire, prodotti per la pulizia per mantenere la bellezza dell'installazione invariata nel tempo.

### Products for installation, finishing and maintenance

In addition to our products, we also provide the products and tools for their installation, finishing and maintenance: tools for assembly and treatment, paints and patinas to refine and embellish, cleaning products to maintain the beauty of the installation over time.



# Maggior valore al tuo acquisto

## Greater value for your purchase



### Un servizio clienti d'eccellenza

Il nostro staff di back office parla fluentemente cinque lingue diverse ed è a vostra disposizione per darvi tutte le informazioni ed il supporto che viservono.

### Excellent customer service

Our back office staff are fluent in five languages, and are on hand to give you all the information and support you need.



### Un ufficio marketing a tua disposizione

Il nostro ufficio marketing è a disposizione per organizzare attività ed elaborare materiale promozionale personalizzato con il logo del cliente. Da anni ormai realizziamo volantini e cataloghi ad hoc per i nostri clienti più affezionati.

### A marketing department at your disposal

Our marketing department is on hand to organise promotional activities and develop customised promotional materials with the customer's logo. We have many years' experience producing custom leaflets and catalogues for our most loyal customers.



### Formazione

Con il nostro personale specializzato, organizziamo incontri di formazione tecnica: tutto ciò che bisogna sapere per progettare ed installare parapetti, cancellate, scale ed altri elementi strutturali a norma di legge.

### Training

With our specialised staff, we organise technical training courses: all you need to know to design and install railings, fences, stairs and other structural elements in accordance with law.

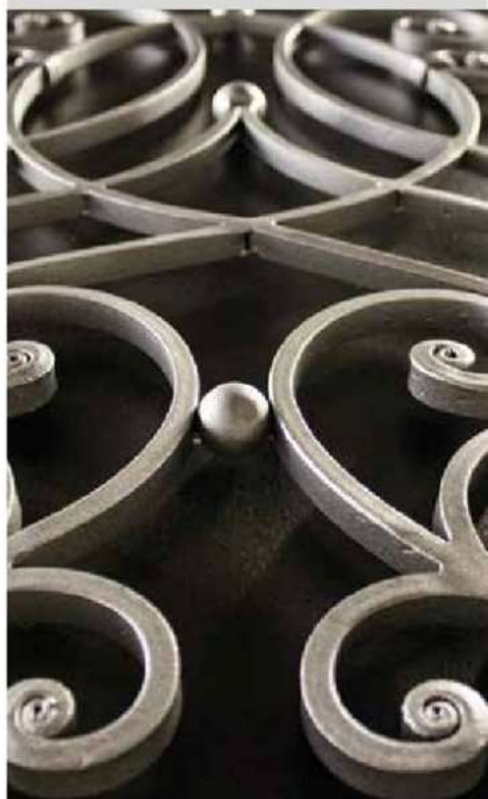

## Qualità garantita, certificata e brevettata

I nostri articoli vengono realizzati nei nostri centri produttivi in Italia e in Europa. Possiamo quindi gestire tutta la catena di produzione garantendo così la migliore qualità finale. Tale qualità è da anni riconosciuta anche dalle certificazioni ottenute ISO 9001 e ISO 14011. Un ulteriore valore aggiunto, sempre a garanzia di originalità e qualità, è rappresentato dai brevetti registrati per molti dei nostri articoli, con lo scopo di tutelare sia l'ingegno dei nostri designer sia la fiducia dei nostri clienti.



## Guaranteed, certified and patented quality

Our articles are made in our productive centres in Italy and Europe. We can manage the entire production line guaranteeing in this way the best final quality. That quality is known for years by certifications ISO 9001 and ISO 14011. Another added value, confirming our originality and quality, is certified by many of our patented articles, in order to protect both the talent of our designers and the trust of our clients.

## Gonzato Contract per un design senza limiti

## Gonzato Contract, for design without limits

# GONZATO

---

# CONTRACT

Gonzato Contract è la divisione di Ind.i.a. spa che si occupa di forniture speciali, in ferro battuto, in acciaio inox o in qualsiasi altro metallo, per prestigiose proprietà private, edifici pubblici, alberghi, spazi comunitari e per ogni tipo di commissione che richieda un approccio custom made, dalla progettazione all'installazione.

Gonzato Contract is the division of Ind.i.a. S.p.A. handling special supplies in wrought iron, stainless steel or any other metal, for prestigious private homes, public buildings, hotels, community spaces, and for all types of commission that require a custom approach, from design to installation.



### Personalizzazione al massimo della qualità!

Dal progetto, alla realizzazione, alla posa in opera ogni passaggio è svolto dai nostri progettisti e tecnici che sapranno soddisfare ogni esigenza strutturale, architettonica ed estetica. Inviaci la pianta del tuo terrazzo o della tua cancellata e penseremo noi a tutto il resto, anche all'installazione!

### Customisation and top quality!

From design to production to installation, every step of the process is carried out by our designers and technicians, to satisfy every structural, architectural and aesthetic requirement. Send us a plan of your terrace or fence and we'll take care of everything else, even the installation!



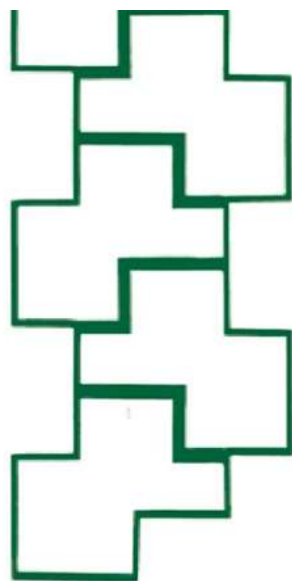
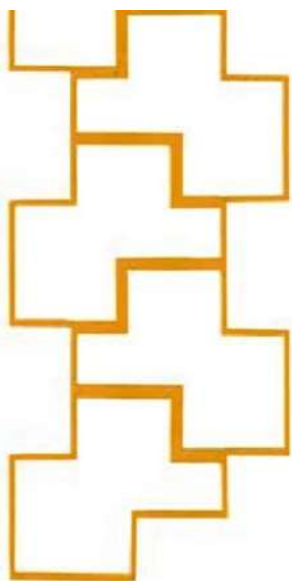
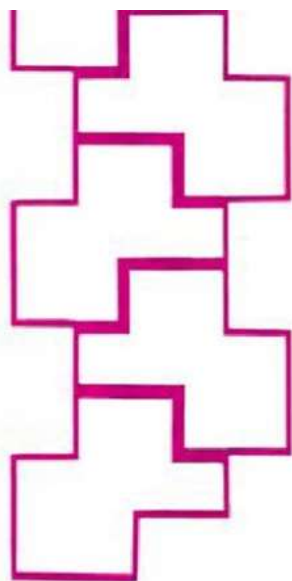

### Finiture speciali materiche Texture finishings



Corten - Corten  
Cod. YAC 180 P



Bronzo - Bronze  
Cod. R 283 SOP



Zinco ossidato - Oxidized Zinc  
Cod. MCB 105 Z



Granito nero - Black Granite  
Cod. SA 161 P



Granito bianco - White Granite  
Cod. YAA 111 P



Ardesia - Slate  
Cod. YAB 062 P

## Colori e Finiture

I prodotti Gonzato Design possono essere verniciati a polveri. La verniciatura a polveri è un procedimento di rivestimento delle superfici metalliche con un film organico, effettuato sia a scopo decorativo sia a scopo di protezione dalla corrosione e dagli agenti aggressivi. Se i prodotti Gonzato Design sono destinati ad uso esterno è consigliabile richiedere che siano zincati prima della verniciatura. Sono disponibili tutti i colori della cartella RAL, più alcune finiture speciali su richiesta che realizziamo grazie al nostro team di maestri verniciatori.

## Colours and Finishes

Gonzato Design products can be powder coated. Powder coating is the process of coating metal surfaces with an organic film, for decorative purposes and protection against corrosion and aggressive substances. If Gonzato Design products are intended for outdoor use, check that they are galvanised before painting. All colours on the RAL colour chart are available, plus some special finishes, available on request, thanks to our team of master painters.

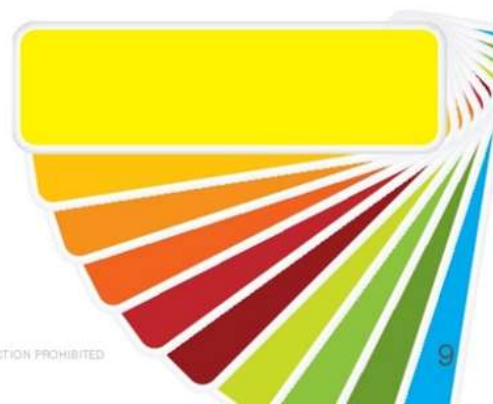

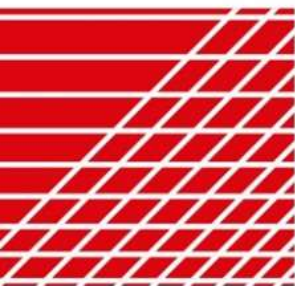

## GEOMETRIC STYLE

Pag.15

La trasposizione della rigidità geometrica negli elementi in ferro battuto.

Geometric rigidity in wrought iron elements.

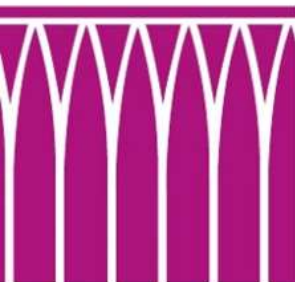

## LINEAR STYLE

Pag. 31

Semplici linee ma sapientemente modellate creano volumi e richiamano il concetto di movimento.

Simple yet skillfully modelled lines create volume and recall the concept of movement.



## FLOREAL STYLE

Pag. 55

Le forme organiche e le linee curve si fondono con ornamenti a predilezione vegetale o floreale.

Organic forms and curved lines blend with plant and floral inspired ornaments.



## WAVES STYLE

Pag. 71

La linea curva come elemento fondante a richiamo dell'immagine del mare increspato o dell'allegoria del vento.

The curved line as a basic element is reminiscent of choppy seas or a representation of the wind.

L'evoluzione del ferro battuto è strettamente legata agli stili e alle tendenze ornamentali che hanno contraddistinto le diverse epoche: il classico, il gotico, il rinascimentale, il barocco, il rococò, il neo-classico, l'impero. Abbiamo quindi scelto di suddividere i prodotti Gonzato Design in base agli stili in cui ognuno di essi è ispirato.

In quanto leader del mercato ci sentiamo responsabili sia di portare avanti la tradizione, sia di apportare innovazione nel nostro settore. Per questo motivo abbiamo creato delle categorie stilistiche nuove che, chissà, tra qualche centinaio d'anni potranno essere annoverate nella storia del ferro battuto.

The evolution of wrought iron is closely linked to the styles and decorative trends that marked the different eras: classical, Gothic, Renaissance, baroque, rococo, neo-classical, Empire. We have therefore chosen to divide the Gonzato Design products according to the styles that inspired them.

As a market leader we feel a responsibility to carry on tradition, but also to bring innovation to our industry. For this reason we have created new stylistic categories, that perhaps in a few hundred years will be considered part of the history of wrought iron.

## IMPERO STYLE

Pag. 83

La combinazione tra fasto e grandiosità con la ricerca di grazia, intimità e leggerezza.

The combination of luxury and grandeur with grace, intimacy and lightness.



## REVOLUTION STYLE

Pag. 93

Linee curve e forme geometriche si ripetono e combinano per dar vita ad uno stile "rivoluzionario"

Curved lines and geometric shapes are repeated and combined to create a 'revolutionary' style.



## NEW CLASSIC STYLE

Pag. 103

Intrecci e disegni che formano archi e volute

Woven lines and designs that form arcs and spirals



## NEW LIBERTY STYLE

Pag. 131

Tra curve, volute e intersezioni, le possibilità del ferro battuto vengono sfruttate fino all'estremo.

Between curves, swirls and intersections, the possibilities of wrought iron are exploited to the extreme.





Personalizza il tuo  
**GONZATO DESIGN**

Ampia scelta di finiture e materiali

Contattaci per qualsiasi richiesta che  
non trovi a catalogo





Customise your  
**GONZATO DESIGN**

with our wide choice of finishes and materials

Contact us for any request that is  
not in our catalogue



## **Design esclusivo e brevettato**

Un valore aggiunto a garanzia di originalità e qualità, è rappresentato dai brevetti registrati per molti dei nostri articoli, con lo scopo di tutelare sia l'ingegno dei nostri designer sia la fiducia dei nostri clienti.



## **Exclusive and patented design**

The patents that we hold for many of our products offer further added value, guaranteeing originality and quality, protecting both the creativity of our designers and the trust of our clients.



# GEOMETRIC STYLE

*La trasposizione della  
rigidità geometrica  
negli elementi in ferro  
battuto.*

*Geometric rigidity  
in wrought iron  
elements.*

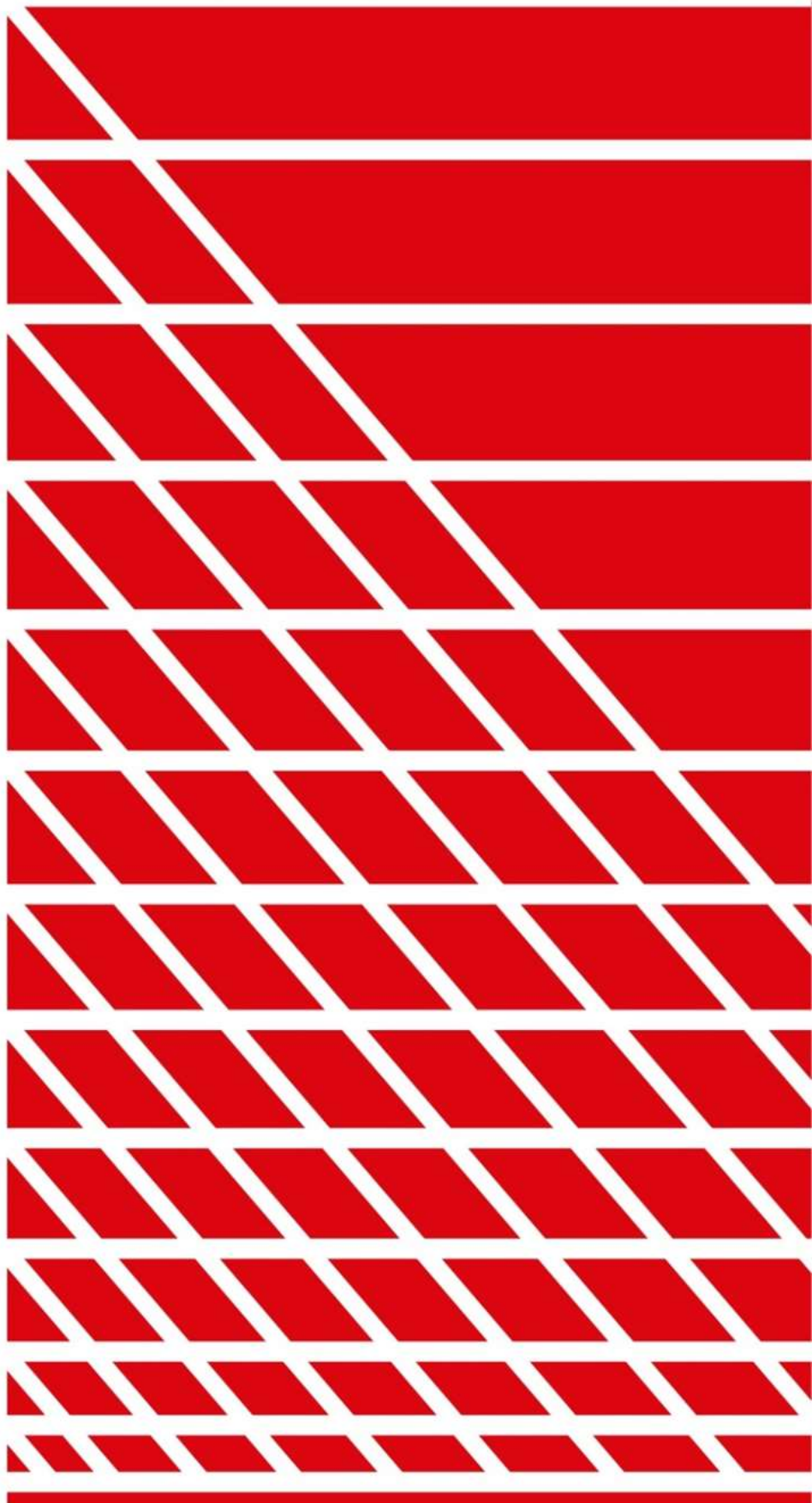

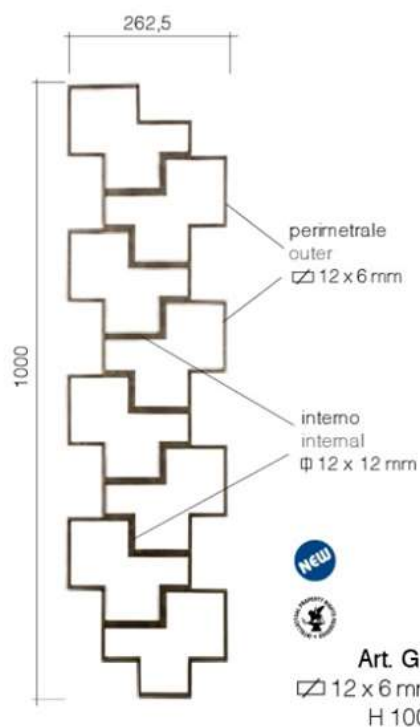

ESEMPIO DI MONTAGGIO  
SU SCALA  
APPLICATION OF  
STAIRCASE

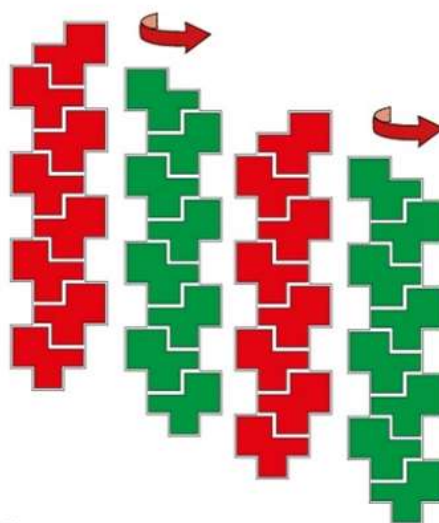

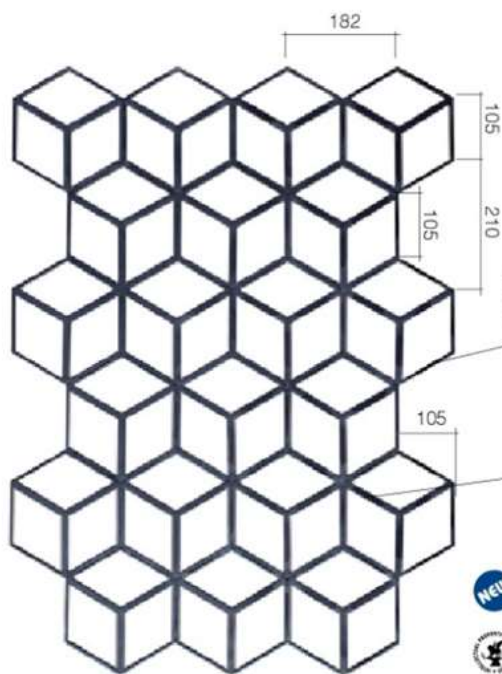

Art. GD287/1  
 $\sphericalangle 12 \times 6 \text{ mm} + \Phi 12 \text{ mm}$   
 H 1000 mm  
 L 728 mm



Art. GD287/2  
 $\sphericalangle 12 \times 6 \text{ mm} + \Phi 12 \text{ mm}$   
 H 1000 mm

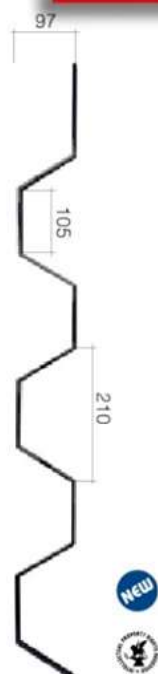

Art. GD287/3  
 $\sphericalangle 12 \times 6 \text{ mm} + \Phi 12 \text{ mm}$   
 H 1000 mm

**ESEMPIO DI MONTAGGIO  
 SU SCALA  
 APPLICATION OF  
 STAIRCASE**

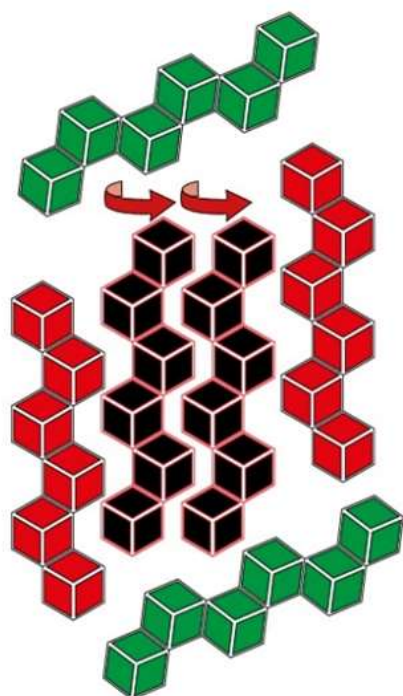

PANNELLI SOVRAPPOSTI  
OVERLAPPED PANELS

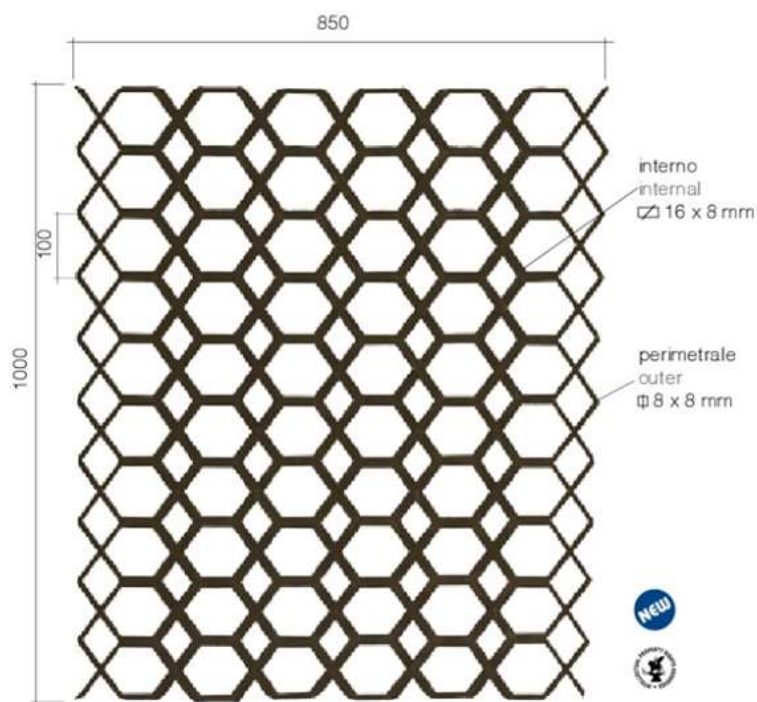

**Art. GD299/1**  
 $\Phi$  8 x 8 mm +  $\square$  16 x 8 mm  
 L 850 mm  
 H 1000 mm

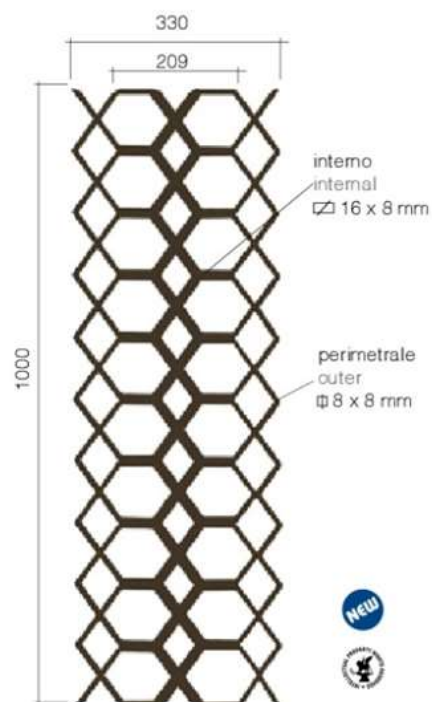

**Art. GD299/2**  
 $\Phi$  8 x 8 mm +  $\square$  16 x 8 mm  
 L 330 mm  
 H 1000 mm

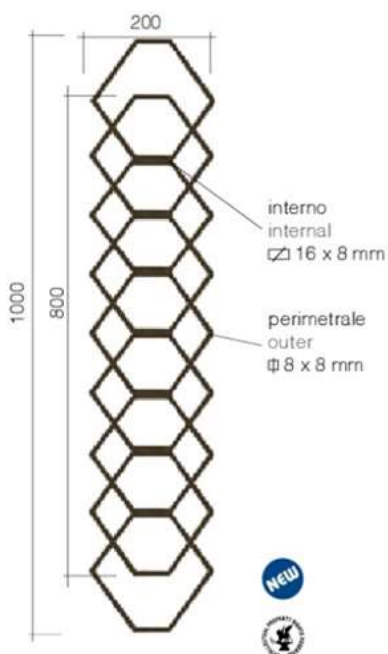

**Art. GD299/3**  
 $\Phi$  8 x 8 mm +  $\square$  16 x 8 mm  
 L 200 mm  
 H 1000 mm

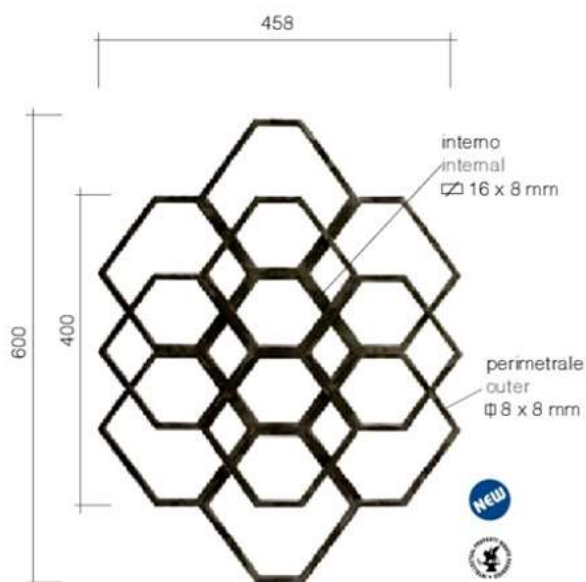

**Art. GD299/4**  
 $\Phi$  8 x 8 mm +  $\square$  16 x 8 mm  
 L 458 mm  
 H 600 mm

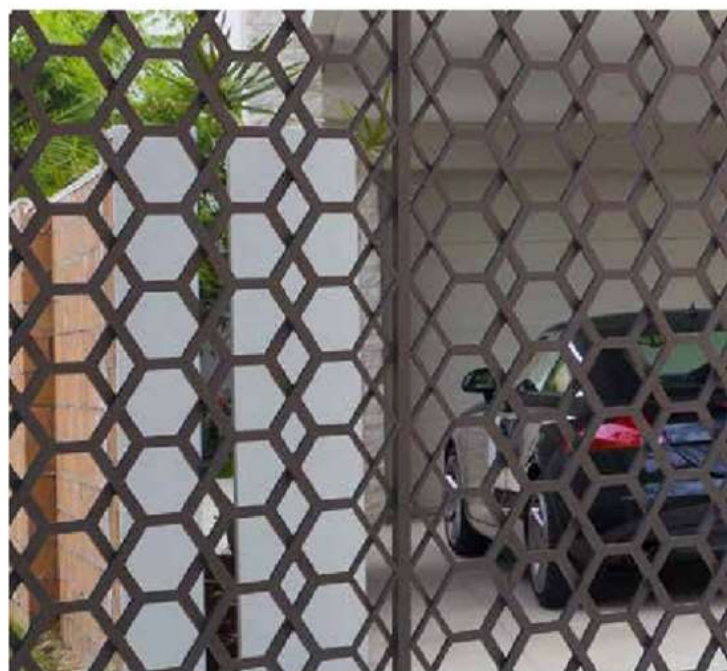

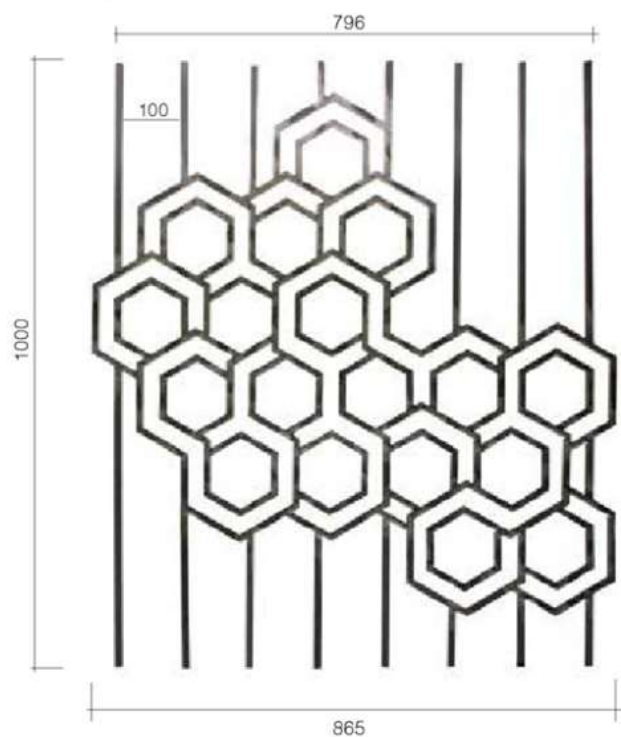

NEW



Art. GD301/1  
 $\Phi$  12 x 12 mm  
 L 865 mm  
 H 1000 mm

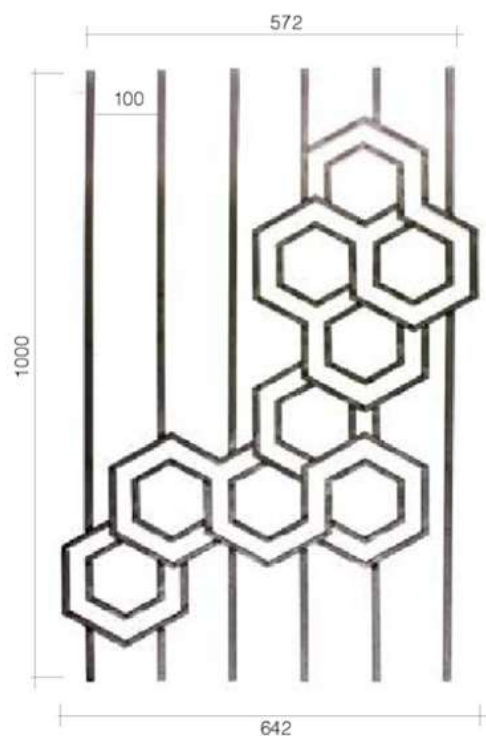
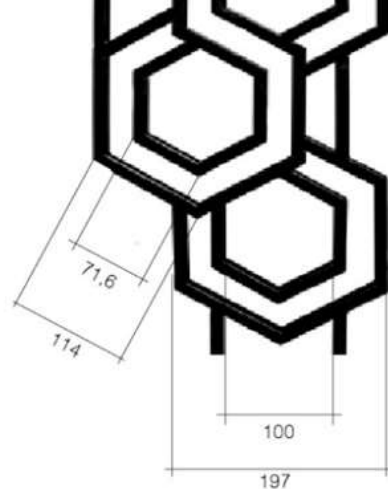

NEW



Art. GD301/2  
 $\Phi$  12 x 12 mm  
 L 642 mm  
 H 1000 mm



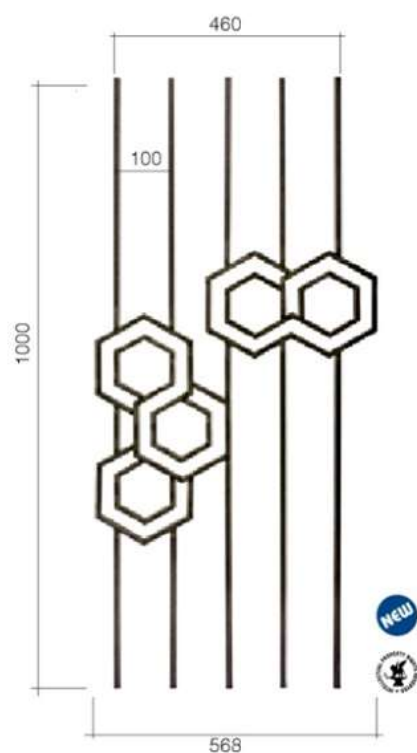

Art. GD301/3  
 $\Phi$  12 x 12 mm  
 L 568 mm  
 H 1000 mm

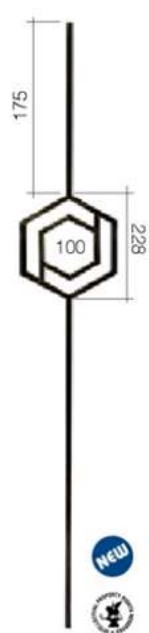

Art. GD301/4  
 $\Phi$  12 x 12 mm  
 L 197 mm  
 H 1000 mm

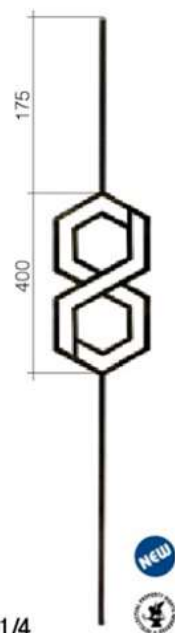

Art. GD301/5  
 $\Phi$  12 x 12 mm  
 L 197 mm  
 H 1000 mm

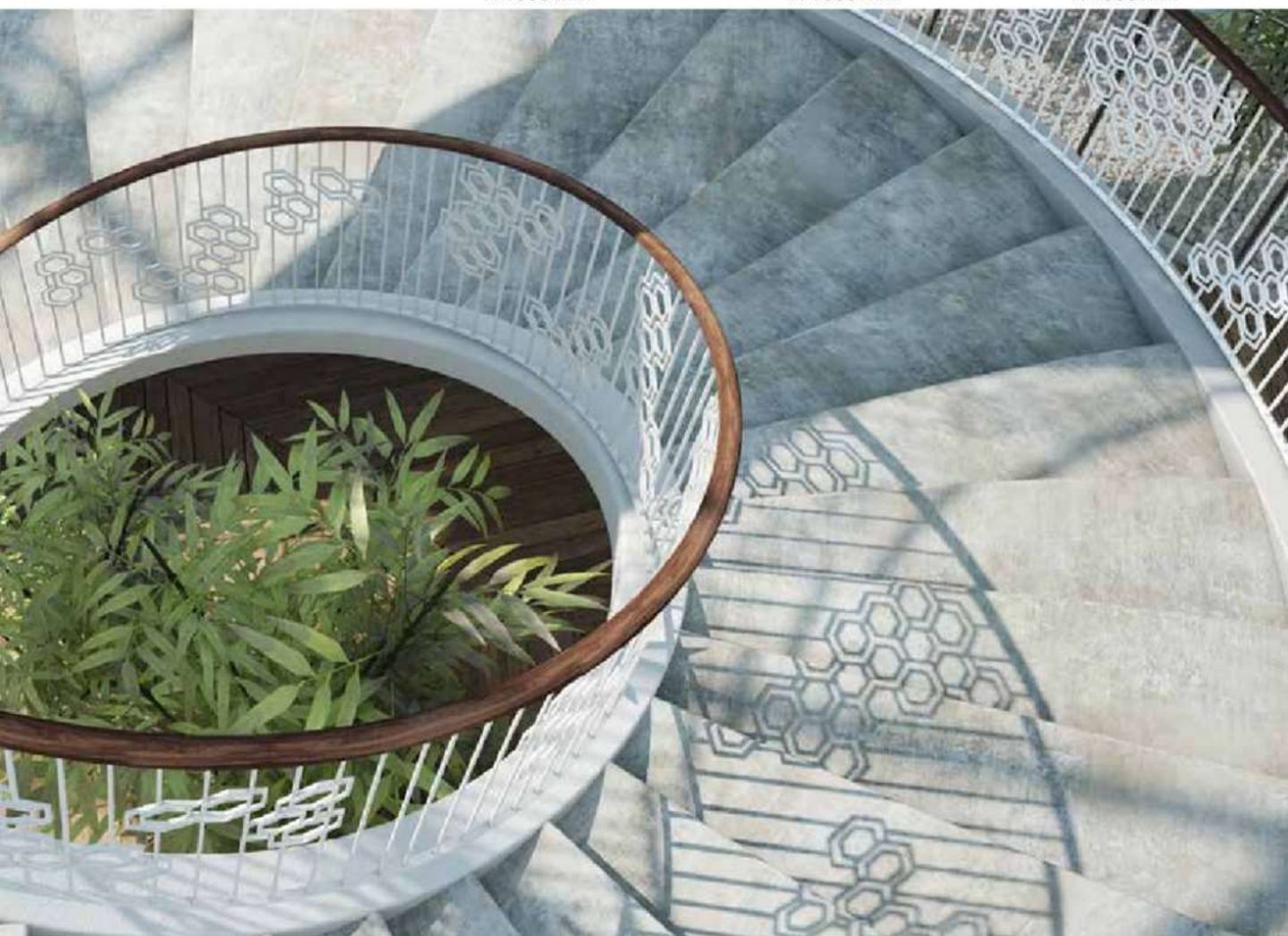



Art. GD23/1  
 Ø 14 mm  
 120 x 1000 mm  
 A = 75 mm  
 Art. GD58/3  
 Ø 12 mm  
 120 x 1000 mm  
 A = 80 mm



Art. GD25/1  
 Ø 14 mm  
 120 x 1000 mm  
 A = 75 mm  
 Art. GD58/2  
 Ø 12 mm  
 120 x 1000 mm  
 A = 80 mm

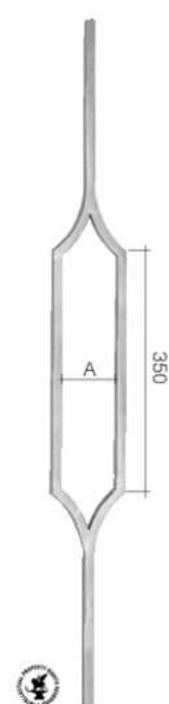

Art. GD25/2  
 Ø 14 mm  
 110 x 1000 mm  
 A = 82 mm  
 Art. GD243/1  
 Ø 12 mm  
 110 x 1000 mm  
 A = 86 mm

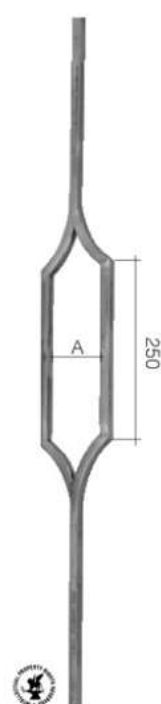

Art. GD25/3  
 Ø 14 mm  
 110 x 1000 mm  
 A = 82 mm  
 Art. GD243/2  
 Ø 12 mm  
 110 x 1000 mm  
 A = 86 mm



Art. GD59/1  
 Ø 12 mm  
 L 70 mm  
 H 1000 mm



Art. GD59/2  
 Ø 12 mm  
 L 60 mm  
 H 1000 mm





Art. 1091/1  
 $\varnothing$  12 mm  
 L 135 mm  
 H 1000 mm



Art. 1091/2  
 $\varnothing$  12 mm  
 L 135 mm  
 H 1000 mm

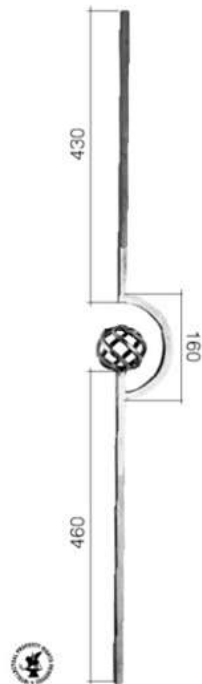

Art. 1090/1  
 $\varnothing$  12 mm  
 L 115 mm  
 H 1000 mm



Art. 1090/2  
 $\varnothing$  12 mm  
 L 115 mm  
 H 1000 mm

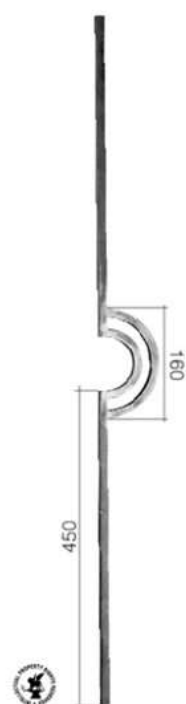

Art. 1090/3  
 $\varnothing$  12 mm  
 L 90 mm  
 H 1000 mm

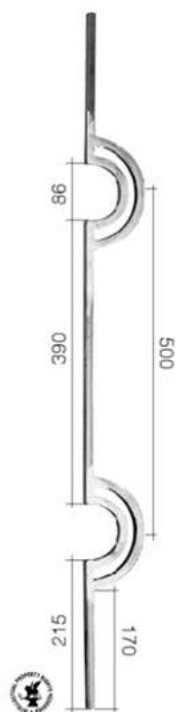

Art. 1090/4  
 $\varnothing$  12 mm  
 L 90 mm  
 H 1000 mm

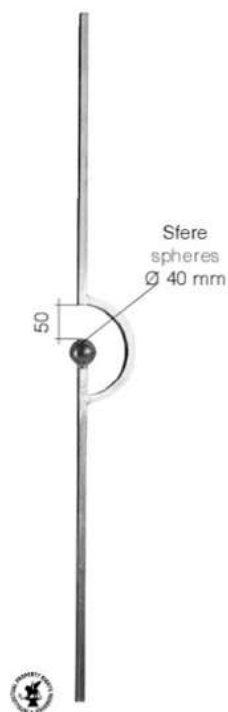

Art. 1089/1  
 $\varnothing$  12 mm  
 L 100 mm  
 H 1000 mm



Art. 1089/2  
 $\varnothing$  12 mm  
 L 100 mm  
 H 1000 mm

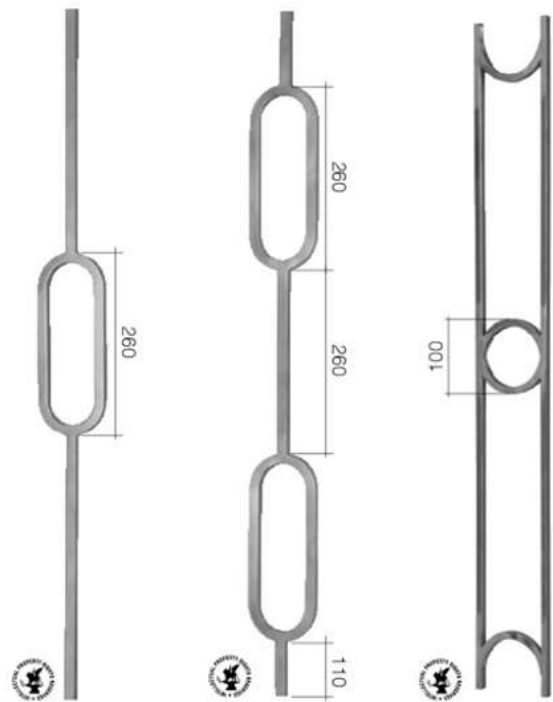

**Art. GD29/1**  
 Ø 14 mm  
 L 100 mm  
 H 1000 mm

**Art. GD29/2**  
 Ø 14 mm  
 L 100 mm  
 H 1000 mm

**Art. GD78/2**  
 Ø 12 mm  
 L 125 mm  
 H 1000 mm

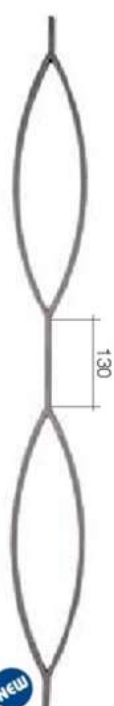

**Art. GD278/1**  
 14 x 8 mm  
 L 105 mm  
 H 1000 mm

**Art. GD278/2**  
 14 x 8 mm  
 L 105 mm  
 H 1000 mm





**Art. GD19/1**  
 □ 14 x 8 mm  
 L 100 mm  
 H 1000 mm

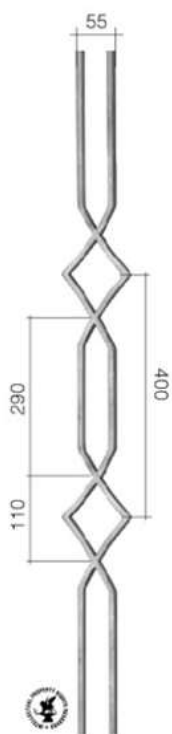

**Art. GD19/2**  
 □ 14 x 8 mm  
 L 100 mm  
 H 1000 mm

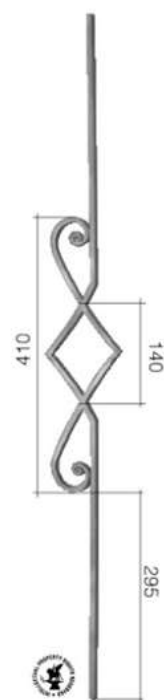

**Art. GD19/4**  
 □ 14 x 8 mm  
 L 100 mm  
 H 1000 mm



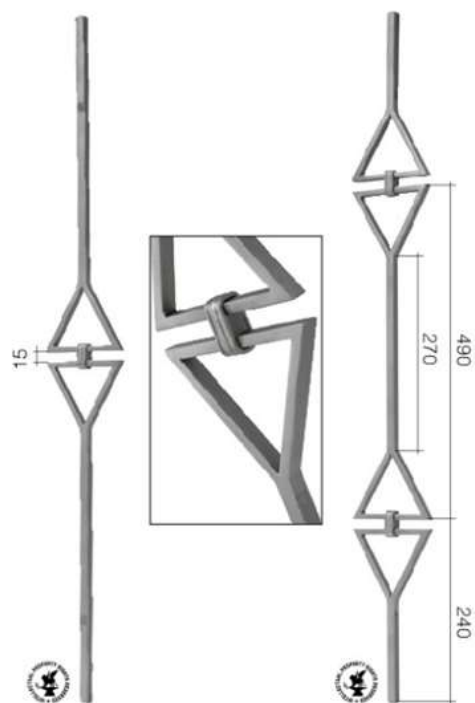

Art. GD181/1

∅ 14 mm  
L 130 mm  
H 1000 mm

Art. GD181/2

∅ 14 mm  
L 130 mm  
H 1000 mm

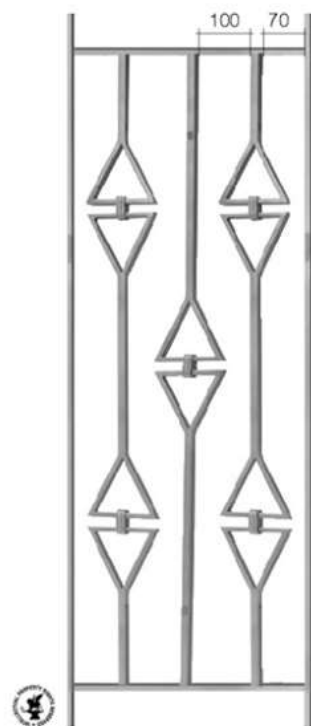

Art. GD181/3

∇ 14 x 8 mm  
L 400 mm  
H 1000 mm



Richiedi il tuo Design su misura!  
*Request Your Custom Design!*



Disponibile nel metallo che vuoi!  
*Available in your choice of metal!*



Tutti gli articoli Gonzato Design sono disponibili in andamento. Indicaci l'angolo di sviluppo della scala!  
*All Gonzato Design articles are available for customisation. Please indicate the angle of the stairs!*

Ornamenti / Ornaments  $\square 14 \times 8$  mm

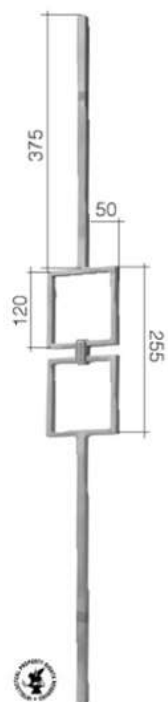

Art. GD182/1  
 $\varnothing 14$  mm  
 L 115 mm  
 H 1000 mm

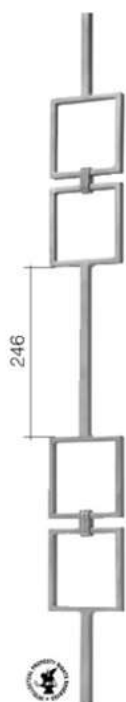

Art. GD182/2  
 $\varnothing 14$  mm  
 L 115 mm  
 H 1000 mm

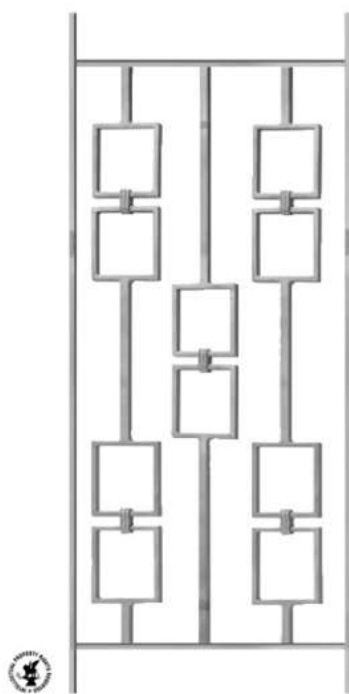

Art. GD183/1  
 $\square 14 \times 8$  mm  
 L 400 mm  
 H 1000 mm



Art. GD184/1  
 $\varnothing 14$  mm  
 L 115 mm  
 H 1000 mm

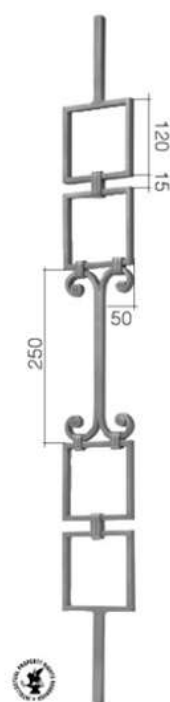

Art. GD184/2  
 $\varnothing 14$  mm  
 L 115 mm  
 H 1000 mm



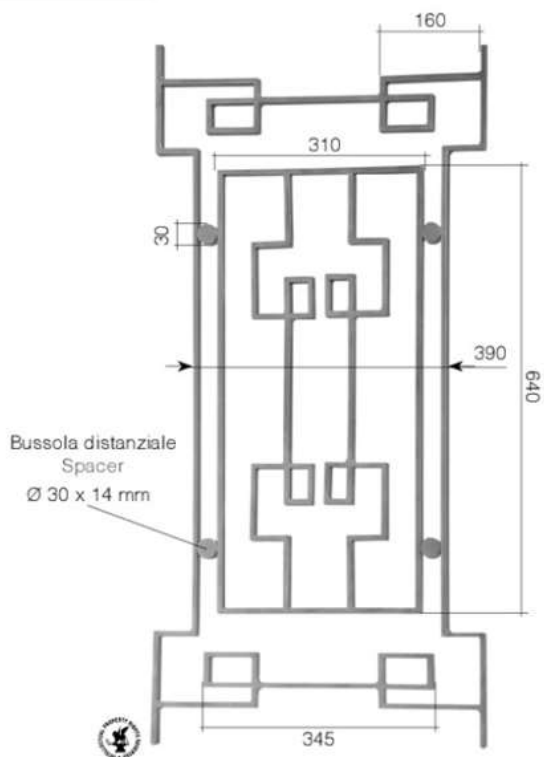

Art. GD202/1  
 □ 14 x 8 mm  
 L 500 mm  
 H 1000 mm



Art. GD202/6  
 □ 14 x 8 mm  
 L 80 mm  
 H 1000 mm

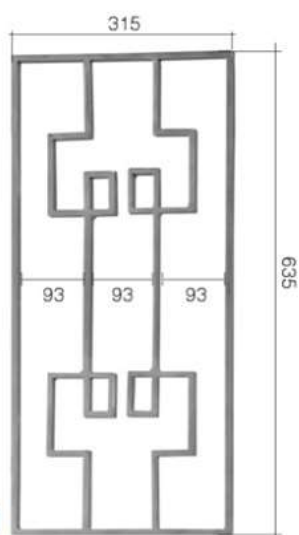

Art. GD202/4  
 □ 14 x 8 mm  
 L 315 mm  
 H 635 mm

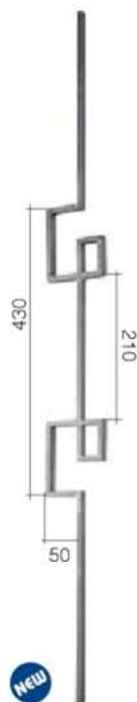

Art. GD202/2  
 □ 14 x 8 mm  
 L 95 mm  
 H 1000 mm



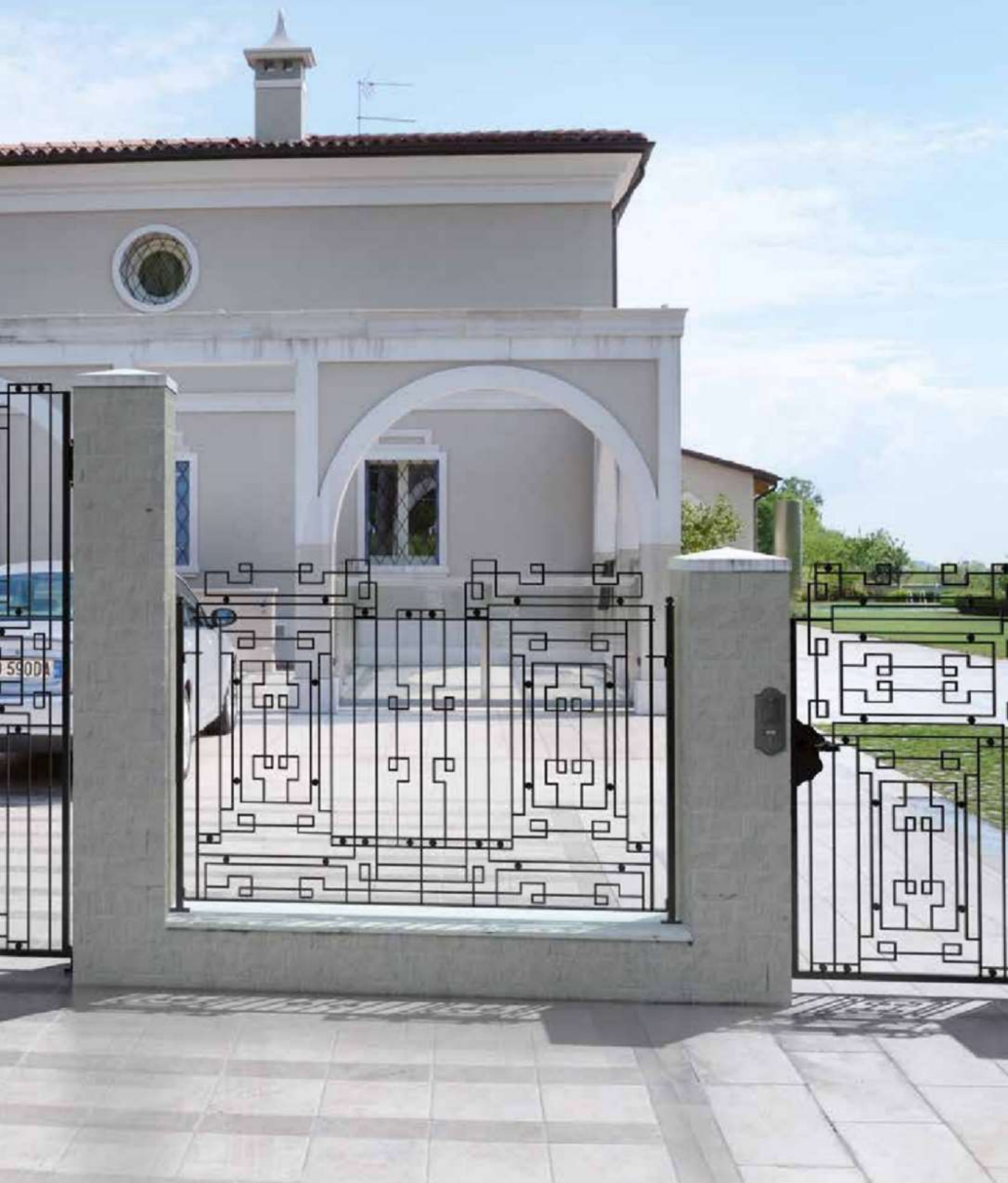



## **Saldature e lavorazioni di alta qualità**

## **Welding and production quality**

I nostri articoli vengono realizzati nei nostri centri produttivi in Italia e in Europa. Possiamo quindi gestire tutta la catena di produzione garantendo così la migliore qualità finale. Tale qualità è da anni riconosciuta anche dalle certificazioni ottenute ISO 9001 e ISO 14011.

Our articles are produced in our production centres in Italy and Europe. We manage the entire production chain, thereby ensuring the best final quality. Our quality has long been recognised by ISO 9001 and ISO 14011 certification.





*Semplici linee ma sapientemente  
modellate creano volumi e  
richiamano il concetto di movimento.*

*Simple but perfectly shaped lines  
create volumes and remember the  
concept of movement.*

## LINEAR STYLE



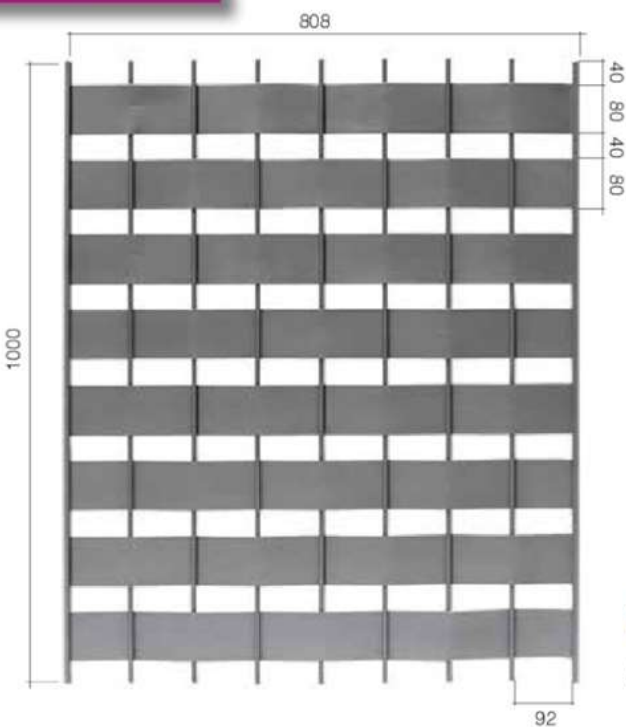

**Art. GD302/1**  
 $\square$  16 x 8 mm  
 L 808 mm  
 H 1000 mm

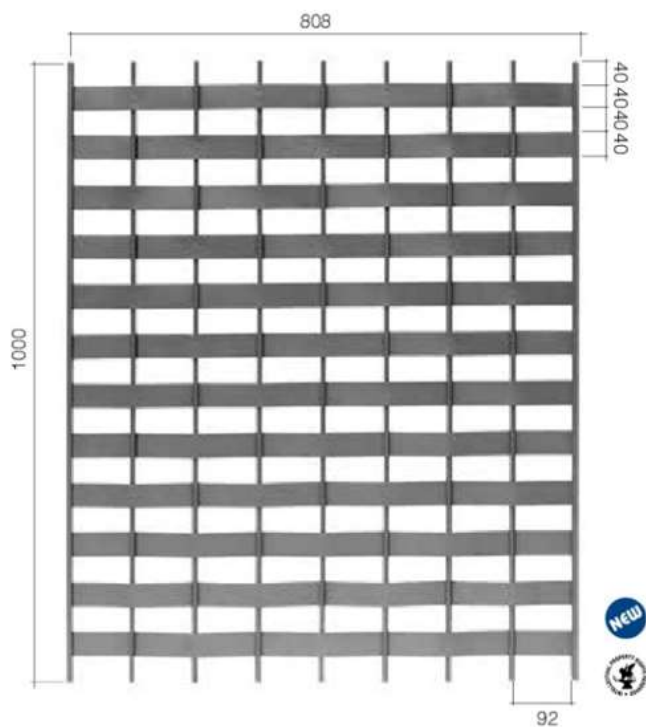

**Art. GD302/2**  
 $\square$  16 x 8 mm  
 L 808 mm  
 H 1000 mm

Pannelli con lamiera spessore 1 mm  
 intrecciata tra tondini  $\varnothing$  8 mm  
 Panels with sheet metal, 1 mm thick  
 woven between rods, 8 mm diameter

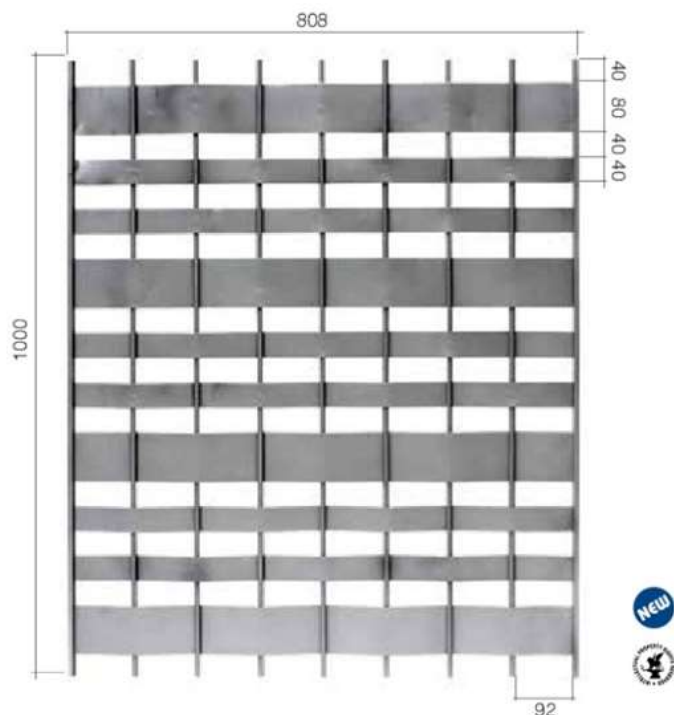
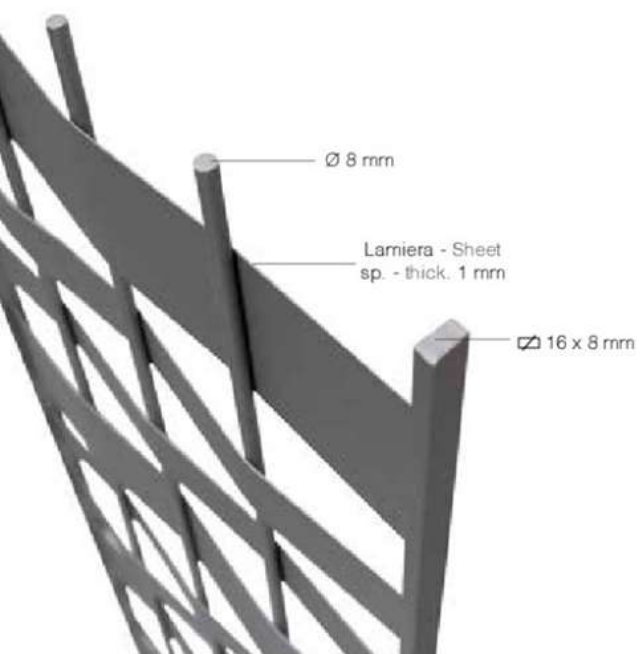

**Art. GD302/3**  
 $\square$  16 x 8 mm  
 L 808 mm  
 H 1000 mm

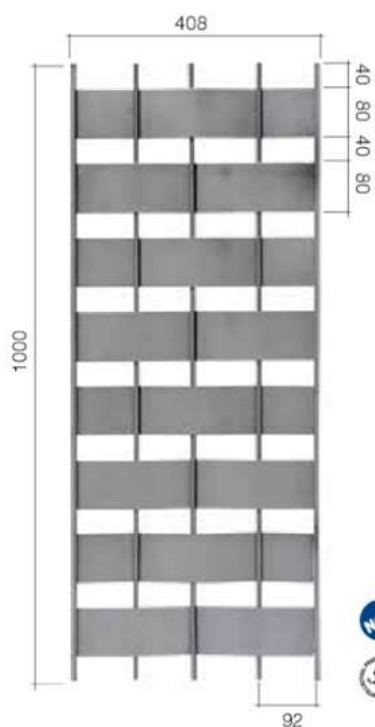

Art. GD303/1  
 $\square$  16 x 8 mm  
 L 408 mm  
 H 1000 mm

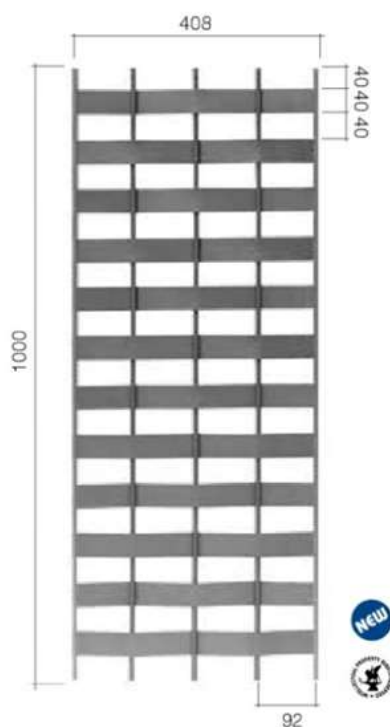

Art. GD303/2  
 $\square$  16 x 8 mm  
 L 408 mm  
 H 1000 mm

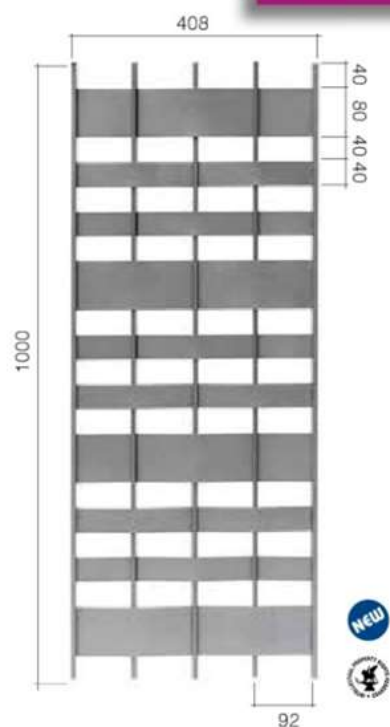

Art. GD303/3  
 $\square$  16 x 8 mm  
 L 408 mm  
 H 1000 mm



Sfere Ø 30 mm - Spheres Ø 30 mm  
Art. 116/F/3

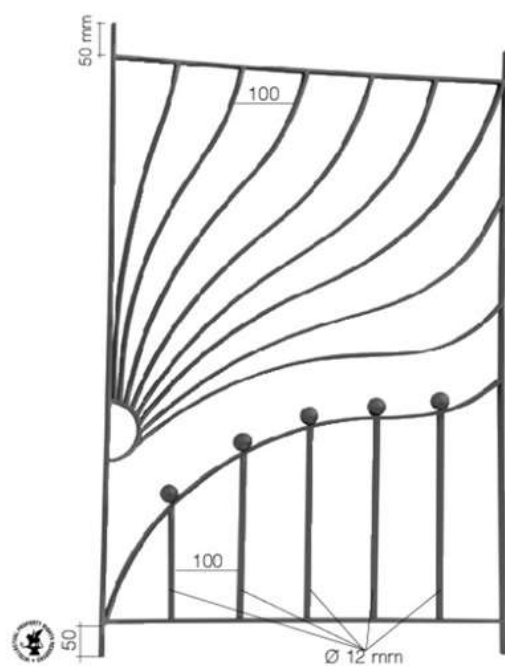

Art. GD247/1  
□ 20 x 6 mm  
L 670 mm  
H 1000 mm



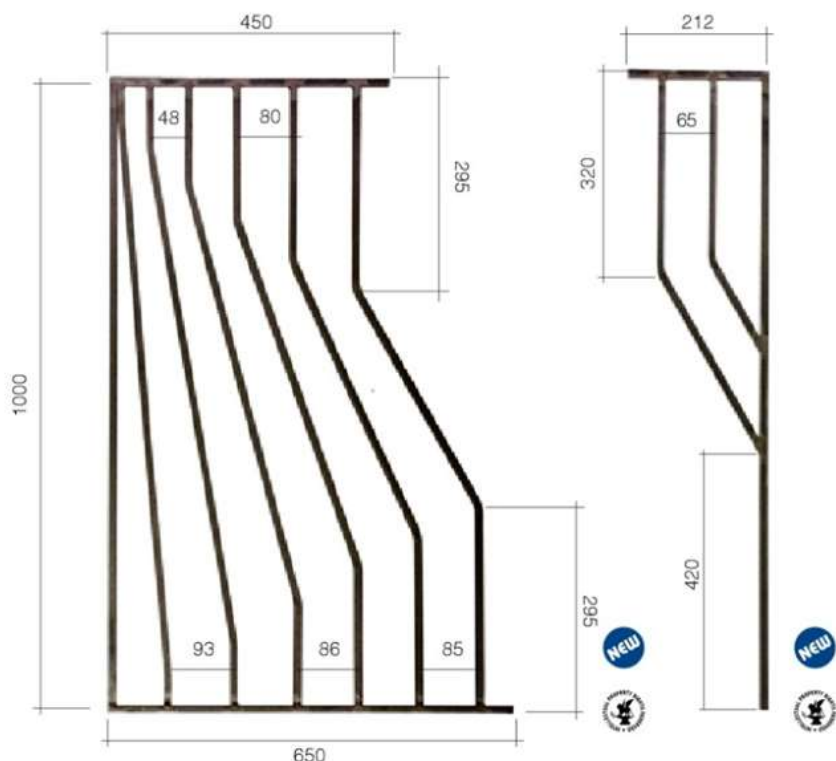

**Art. GD212/2**  
 $\Phi$  12 x 12 mm  
 L 650 mm  
 H 1000 mm

**Art. GD212/3**  
 $\Phi$  12 x 12 mm  
 L 212 mm  
 H 1000 mm

**ESEMPIO DI MONTAGGIO**  
**MOUNTING EXAMPLE**

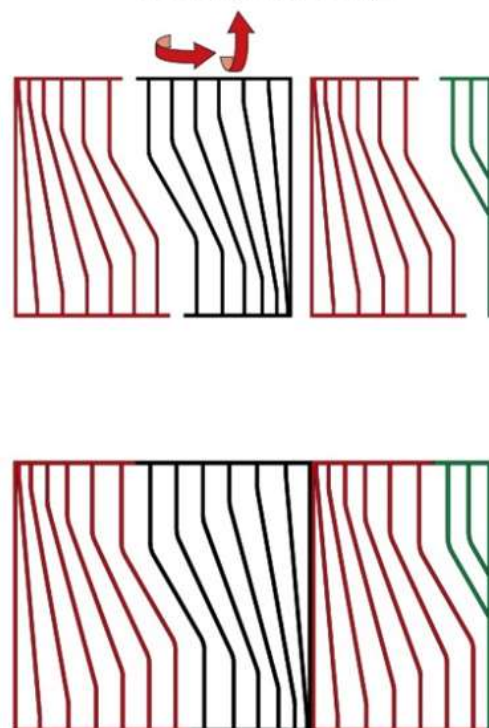



Elementi sovrapposti  
Overlapped elements  
□ 12 x 6 mm

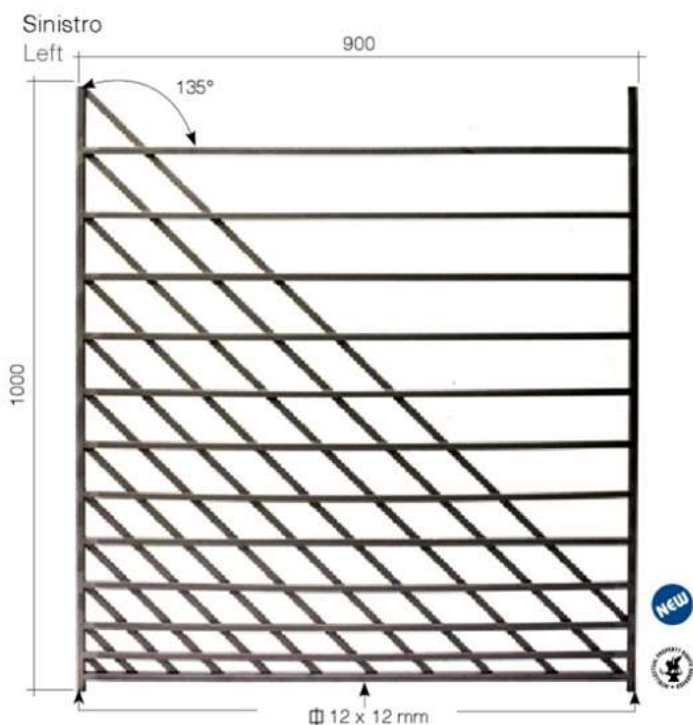

sinistro - left <b>Art. GD297/1</b> □ 12 x 6 mm + φ 12 mm L 900 mm H 1000 mm	destro - right <b>Art. GD297/2</b> □ 12 x 6 mm + φ 12 mm L 900 mm H 1000 mm
--	---



Richiedi il tuo Design su misura!  
*Request Your Custom Design!*



Disponibile nel metallo che vuoi!  
*Available in your choice of metal!*



Tutti gli articoli Gonzato Design sono disponibili in andamento. Indicaci l'angolo di sviluppo della scala!  
*All Gonzato Design articles are available for customisation. Please indicate the angle of the stairs!*

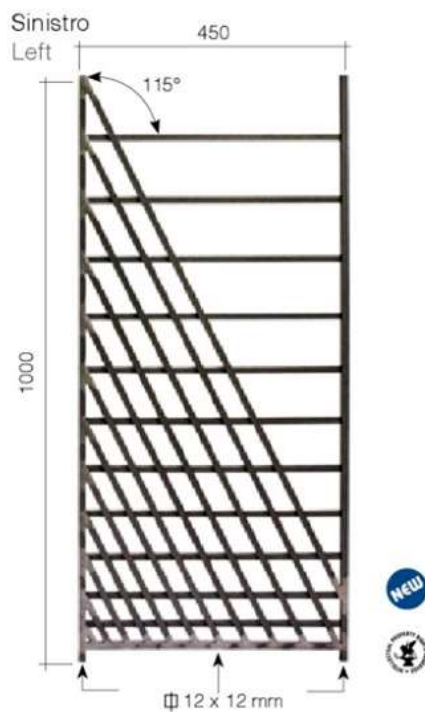

sinistro - left <b>Art. GD298/1</b> □ 12 x 6 mm + φ 12 mm L 450 mm H 1000 mm	destro - right <b>Art. GD298/2</b> □ 12 x 6 mm + φ 12 mm L 450 mm H 1000 mm
--	---

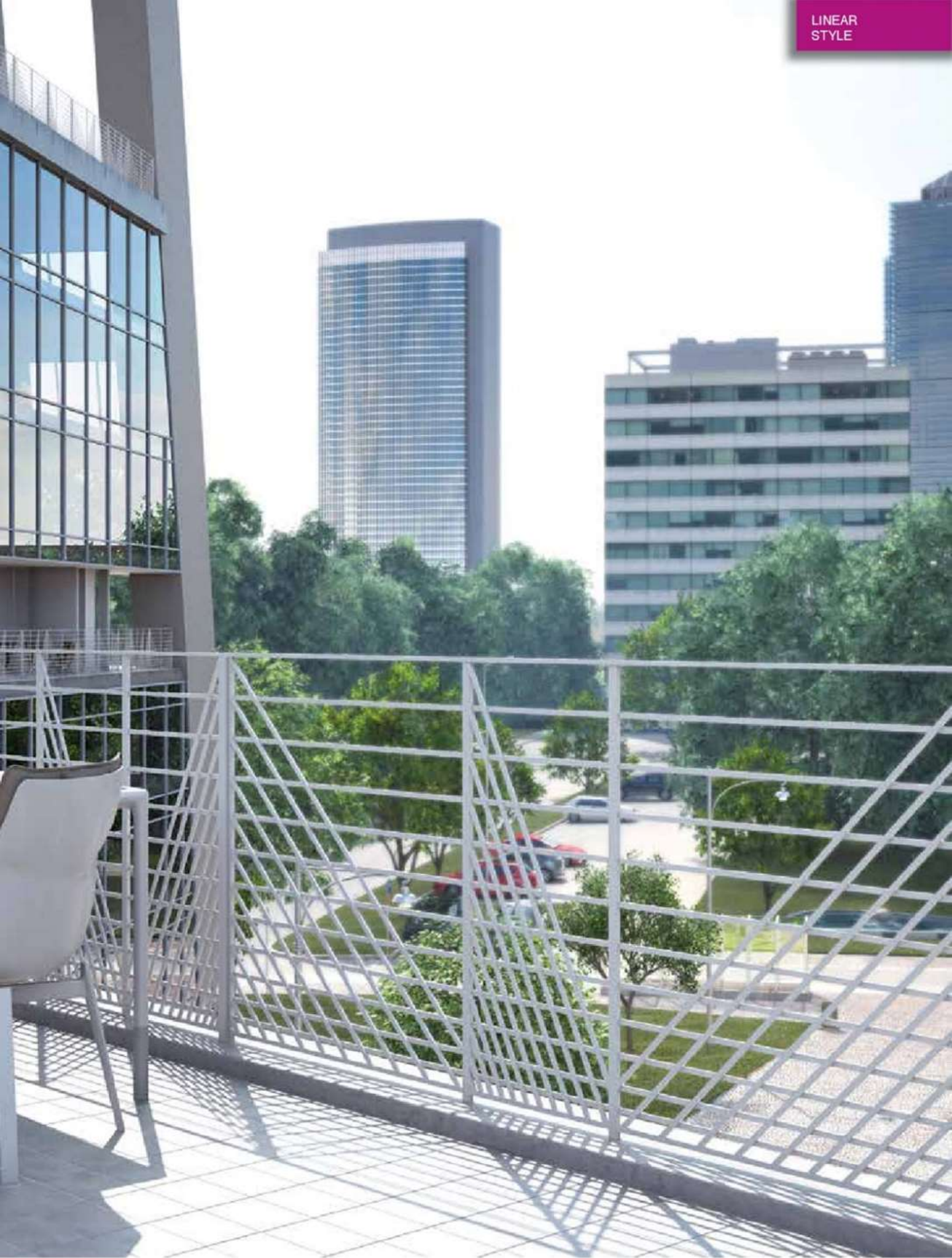





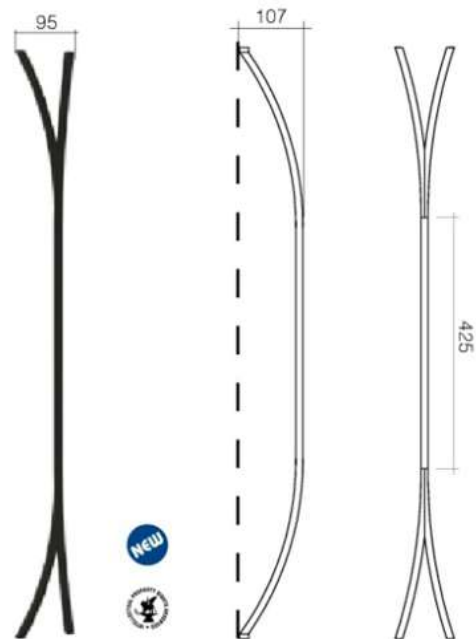

Art. GD290/1  
 $\varnothing$  12 x 12 mm  
 H 1000 mm

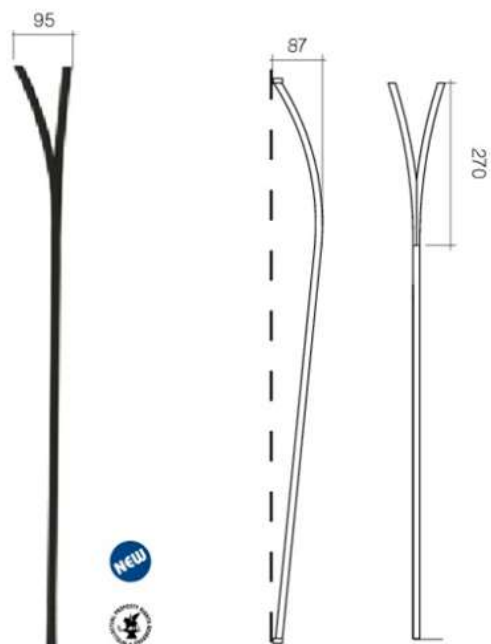

Art. GD290/2  
 $\varnothing$  12 x 12 mm  
 H 1000 mm

elementi verticali Ø 12 mm  
elementi orizzontali Ø 12 mm

vertical elements Ø 12 mm  
horizontal elements Ø 12 mm

1200

96

Ø 12 mm

12

210

Sinistro  
Left

sinistro/left  
Art. GD294/1  
Ø 12 mm  
L 1200 mm  
H 1000 mm

destra/right  
Art. GD294/1/S  
Ø 12 mm  
L 1200 mm  
H 1000 mm

Sinistro  
Left

336

96

12

1000

115

NEW



NEW



sinistro/left  
Art. GD294/3  
Ø 12 mm  
L 336 mm  
H 1000 mm

destra/right  
Art. GD294/3/S  
Ø 12 mm  
L 336 mm  
H 1000 mm

Elementi per portare  
l'onda di tamponatura a  
livello zero

Elements to lead the  
buffing waves at level  
zero



elementi verticali Ø 12 mm  
elementi orizzontali Ø 12 mm

vertical elements Ø 12 mm  
horizontal elements Ø 12 mm

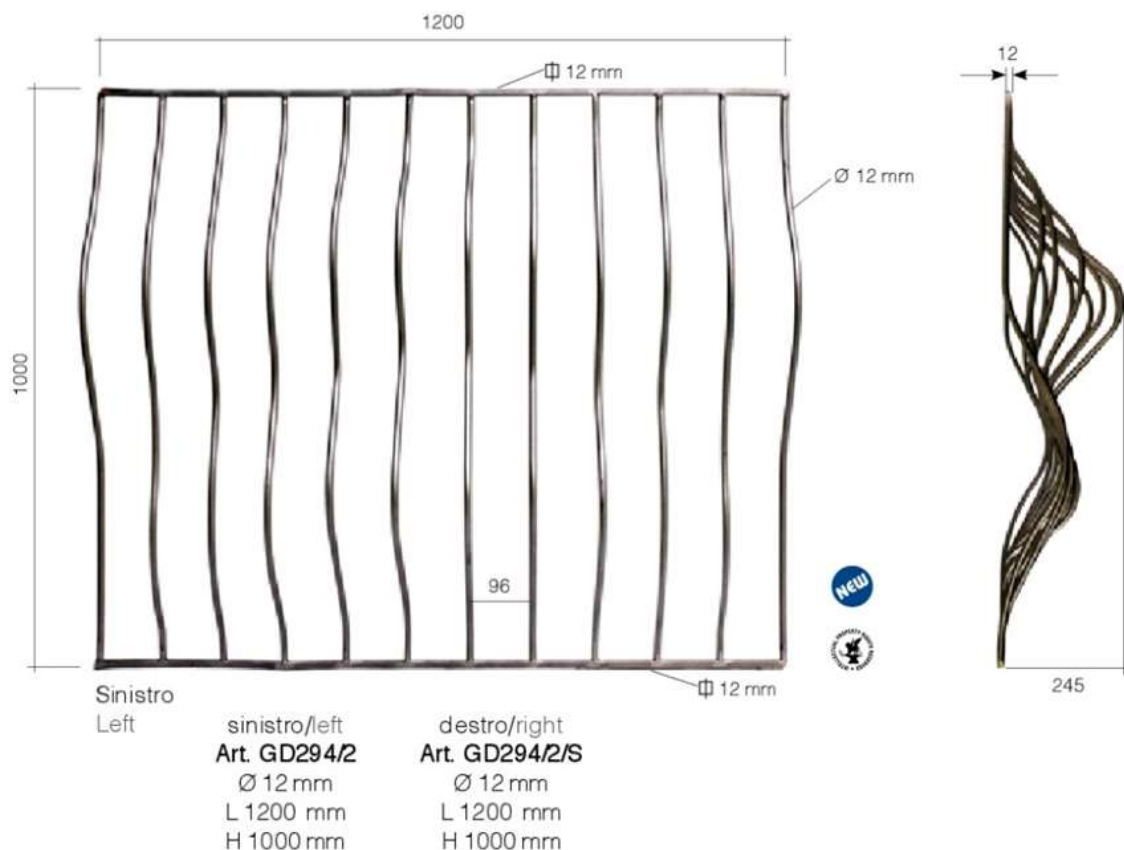

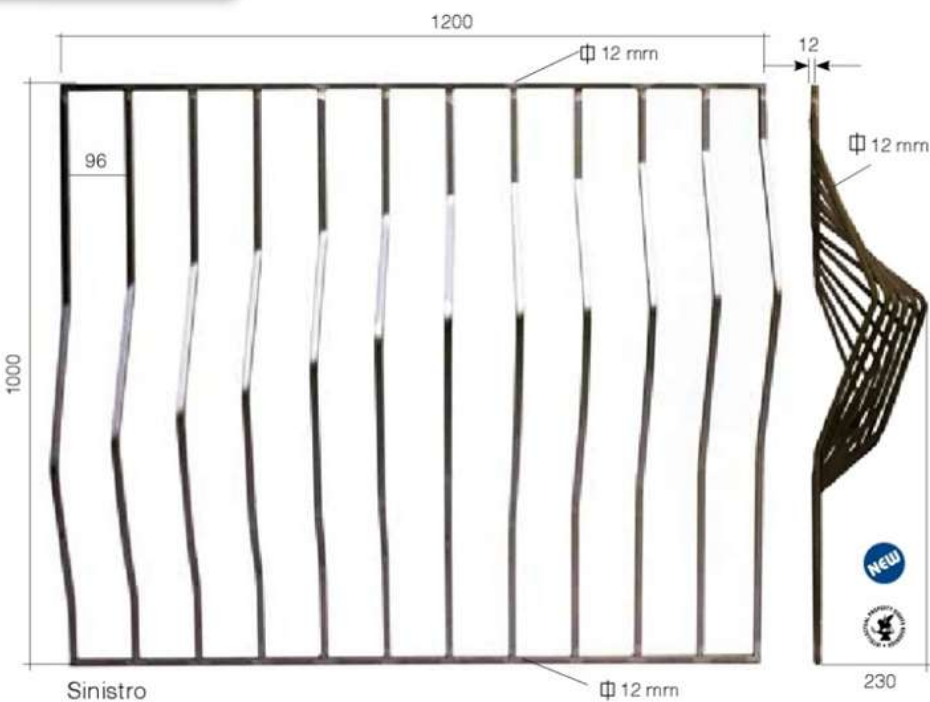

Sinistro  
Left

sinistro - left  
**Art. GD289/2**  
Φ 12 x 12 mm  
L 1200 mm  
H 1000 mm

destra/right  
**Art. GD289/2/S**  
Φ 12 x 12 mm  
L 1200 mm  
H 1000 mm

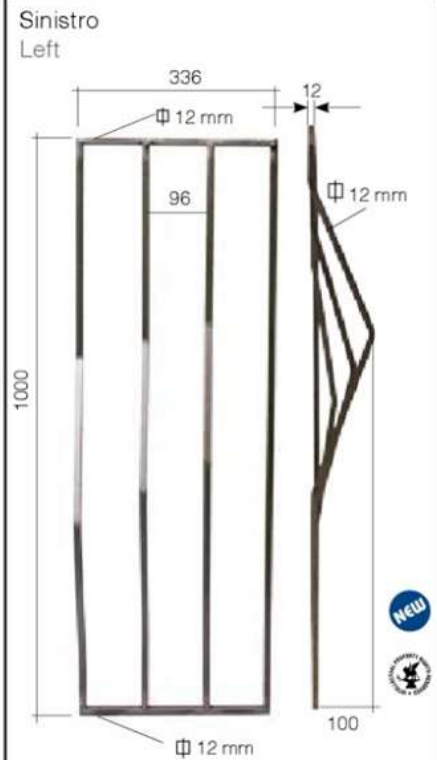

sinistro - left  
**Art. GD293/3**  
Φ 12 x 12 mm  
L 336 mm  
H 1000 mm

destra/right  
**Art. GD293/3/S**  
Φ 12 x 12 mm  
L 336 mm  
H 1000 mm

Elementi per portare  
l'onda di tamponatura a  
livello zero

Elements to lead the  
buffing waves at level  
zero

Gli articoli che compongono questa foto sono

GD289/2 - GD289/2/S  
GD293/3 - GD293/3/S

The items shown in this photo are:

GD289/2 - GD289/2/S  
GD293/3 - GD293/3/S



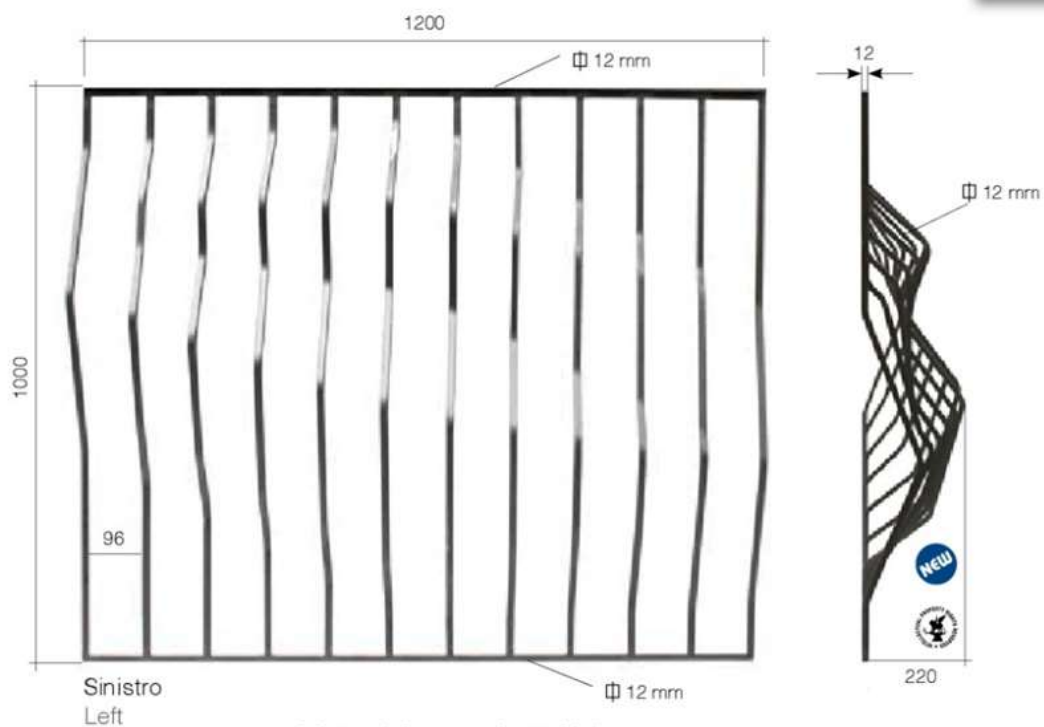

Sinistro  
Left

sinistro - left  
**Art. GD289/I**  
Φ 12 x 12 mm  
L 1200 mm  
H 1000 mm

destra/right  
**Art. GD289/I/S**  
Φ 12 x 12 mm  
L 1200 mm  
H 1000 mm

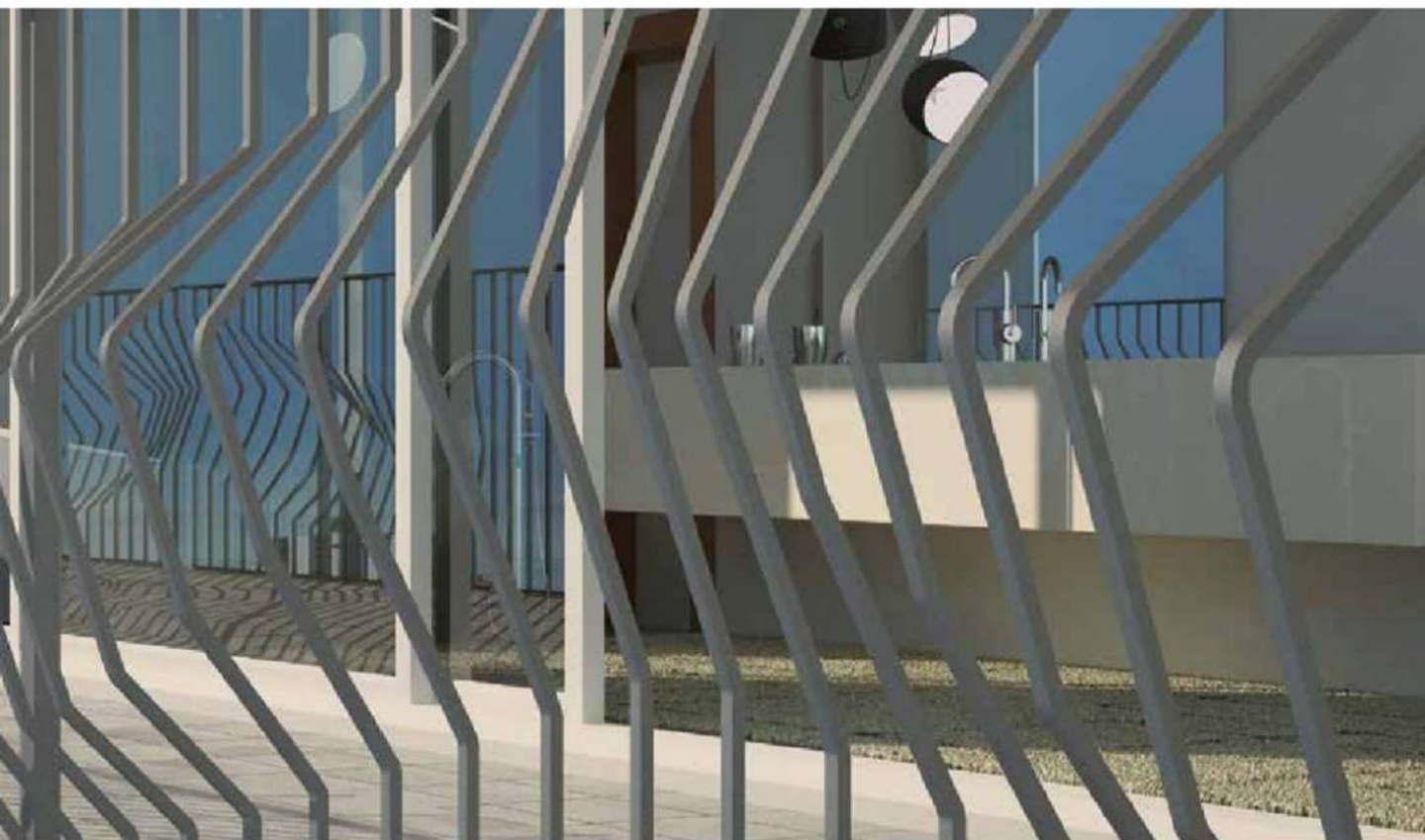

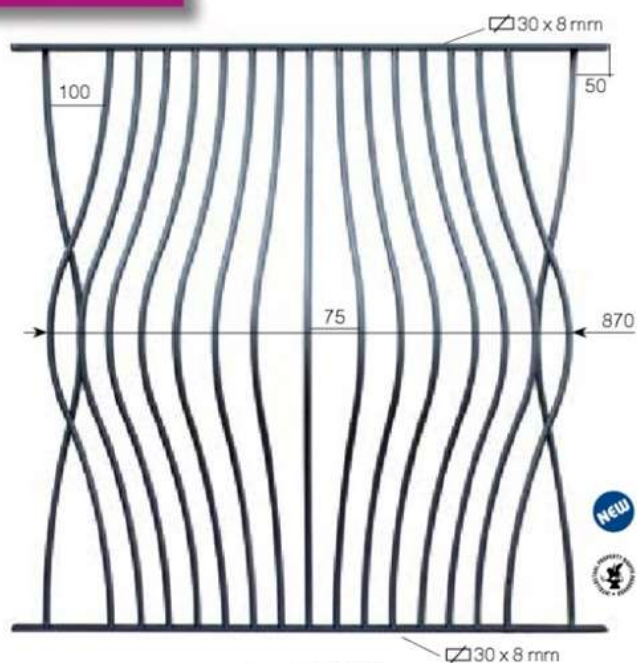

Art. GD288/1  
 Ø 12 mm  
 L1000 mm  
 H 1000 mm



elementi verticali Ø 12 mm  
 elementi orizzontali 30 x 8 mm  
 vertical elements Ø 12 mm  
 horizontal elements 30 x 8 mm

Ø 12 mm



Elementi sovrapposti  
 Overlapped elements



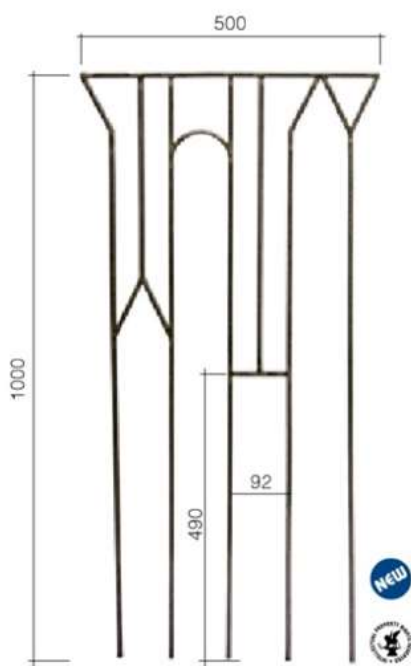

Art. GD295/1  
 ▧ 14 x 8 mm  
 L 500 mm  
 H 1000 mm

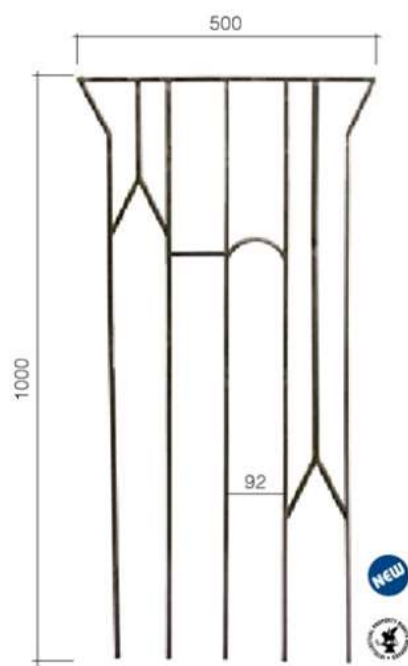

Art. GD295/2  
 ▧ 14 x 8 mm  
 L 500 mm  
 H 1000 mm







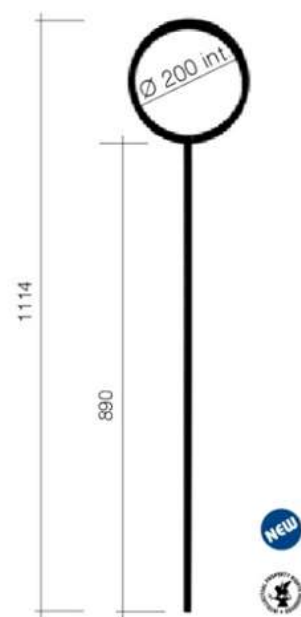

Art. GD296/2  
 $\Phi$  12 x 12 mm  
 L  $\Phi$  224 mm  
 H 1114 mm

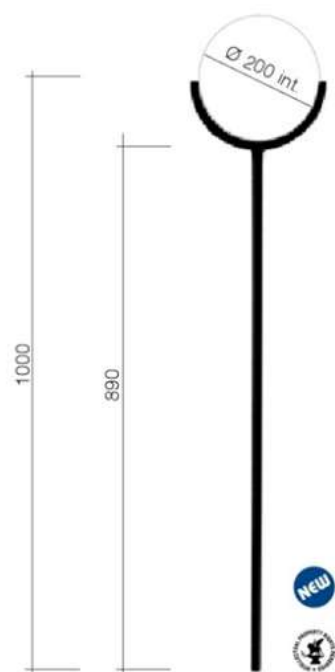

Art. GD296/1  
 $\Phi$  12 x 12 mm  
 L  $\Phi$  224 mm  
 H 1000 mm

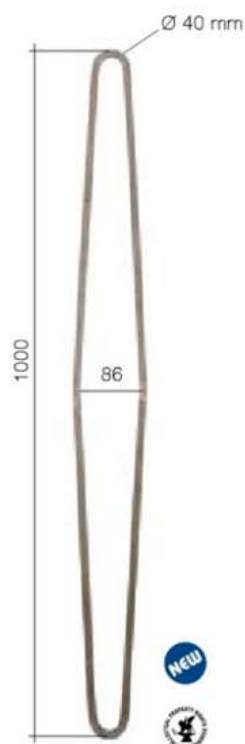

Art. GD293/2  
Ø 12 x 12 mm  
L 110 mm  
H 1000 mm



Fascette - Collars  
Art. 158/3  
14 x 4 mm

310

920

100

NEW



Art. GD179/1  
14 x 8 mm  
L 115 mm  
H 1000 mm

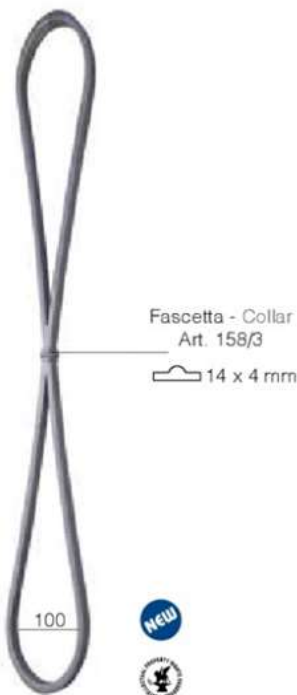

Fascetta - Collar  
Art. 158/3  
14 x 4 mm

100

NEW



Art. GD179/2  
14 x 8 mm  
L 115 mm  
H 1000 mm



Richiedi il tuo Design su misura!  
*Request Your Custom Design!*



Disponibile nel metallo che vuoi!  
*Available in your choice of metal!*



Tutti gli articoli Gonzato Design sono disponibili in andamento. Indicaci l'angolo di sviluppo della scala!  
*All Gonzato Design articles are available for customisation. Please indicate the angle of the stairs!*



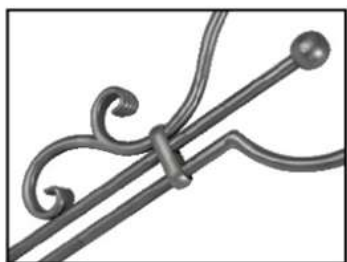

Sfere vuote Ø 30 mm  
Hollow spheres  
Ø 30 mm

profilo/profile  
art. 158/6  
14 x 4 mm

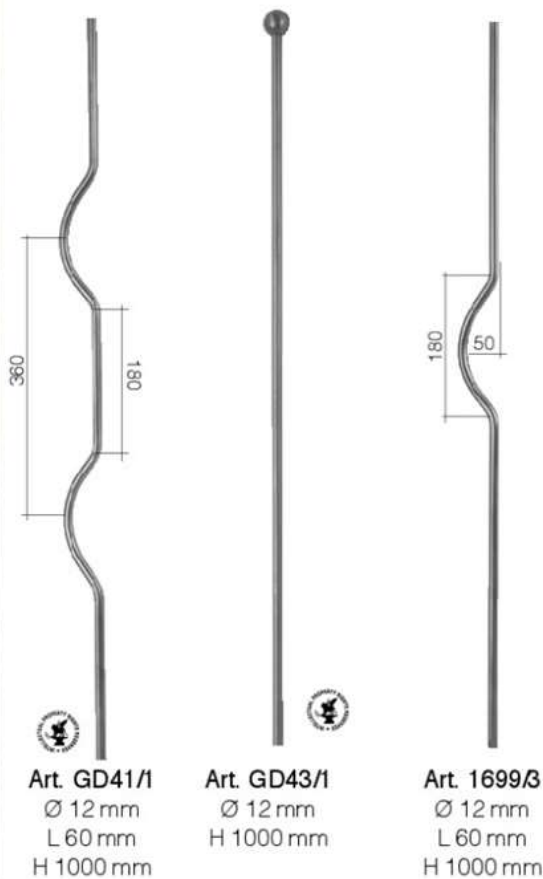
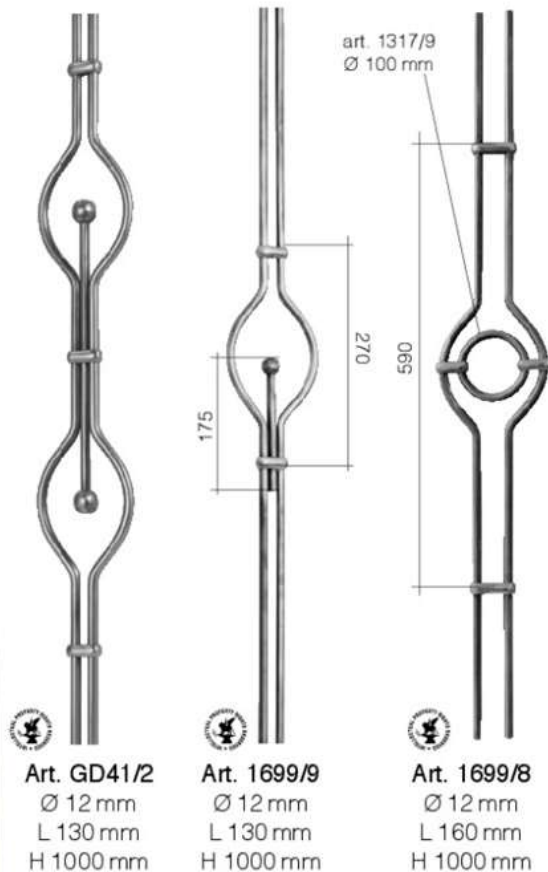

Sfere vuote Ø 30 mm  
Hollow spheres Ø 30 mm

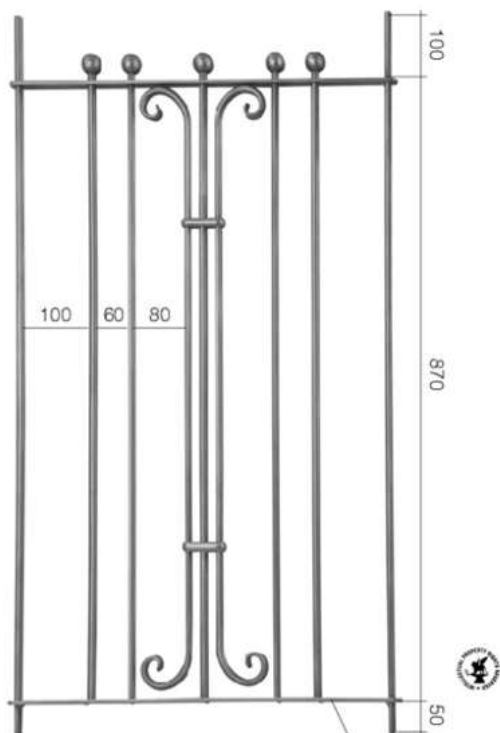

Art. GD45/1

Ø 12 mm  
L 610 mm  
H 1000 mm

25 x 6 mm

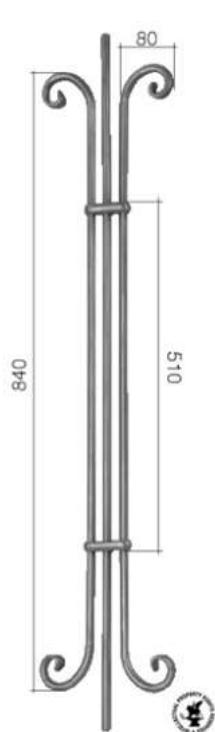

Art. GD45/2

Ø 12 mm  
L 200 mm  
H 1000 mm

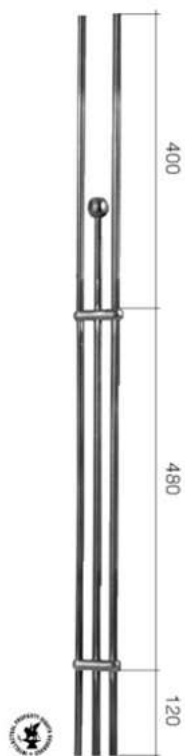

Art. GD39/2

Ø 12 mm  
L 60 mm  
H 1000 mm



Sfere vuote Ø 30 mm  
Hollow spheres  
Ø 30 mm

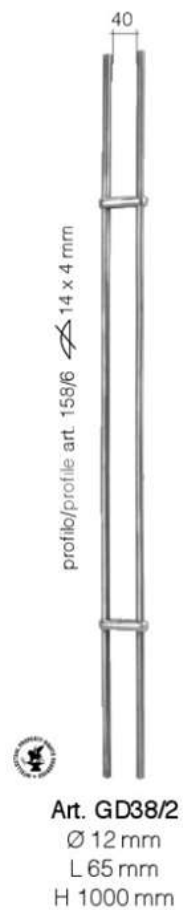
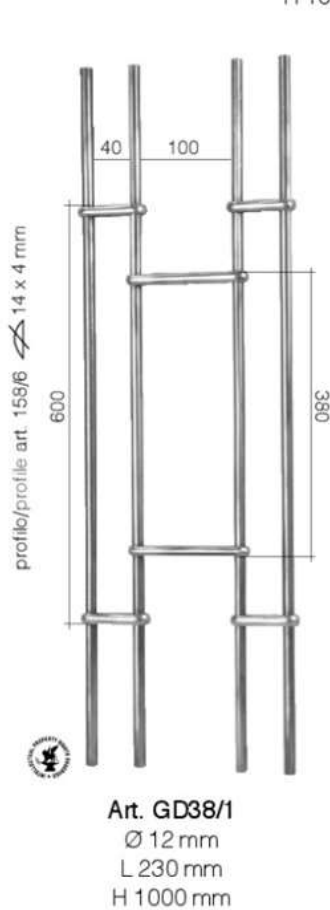
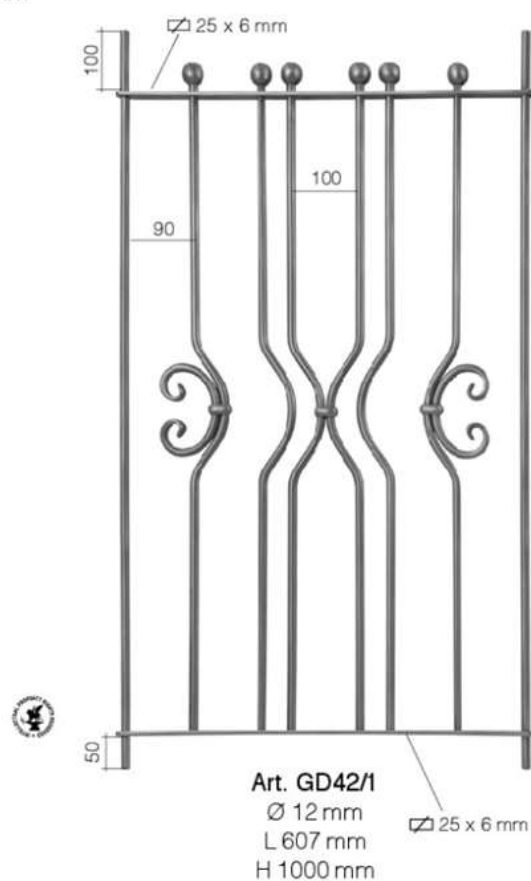
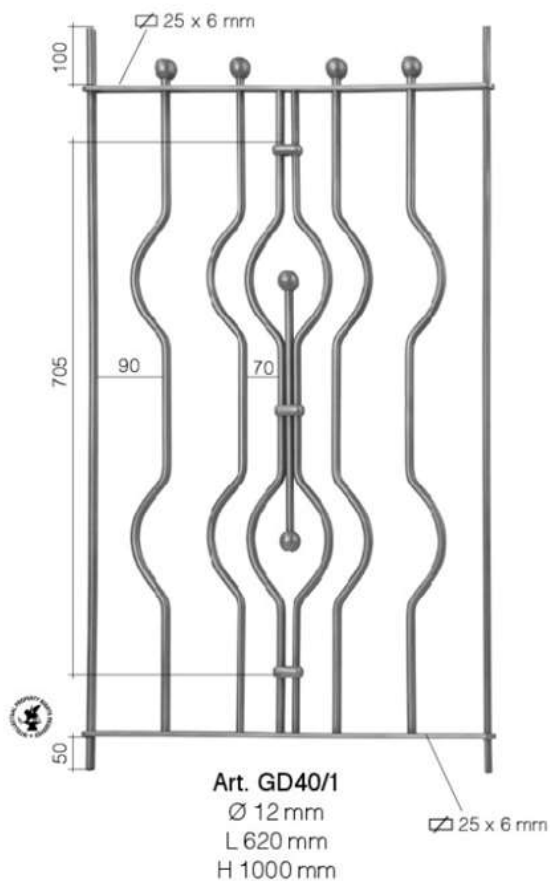

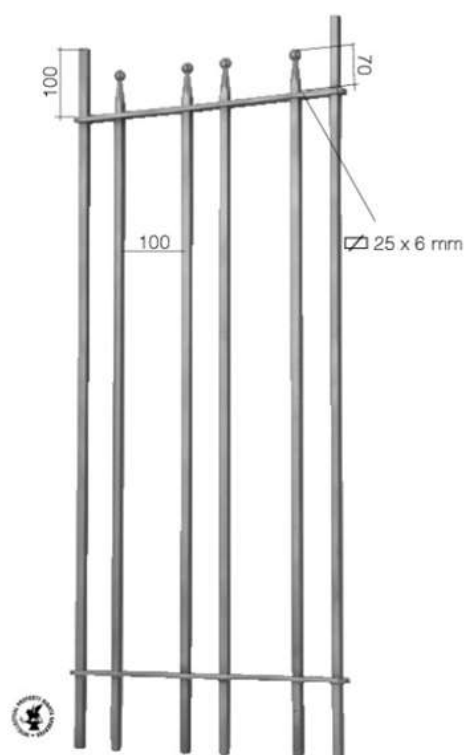

**Art. GD66/2**  
 $\Phi$  12 x 12 mm  
 L 425 mm  
 H 1000 mm

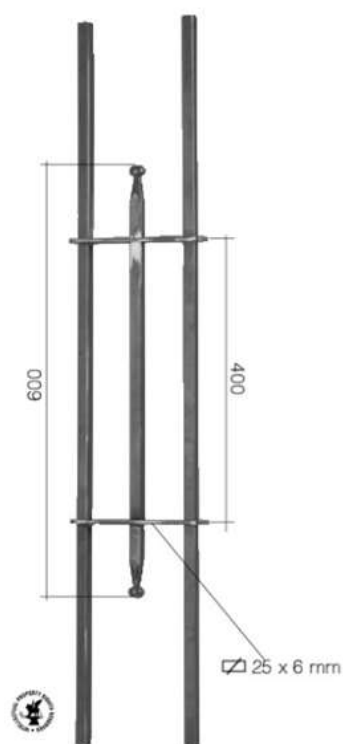

**Art. GD66/1**  
 $\Phi$  12 x 12 mm  
 L 125 mm  
 H 1000 mm

Piatti orizzontali - Horizontal flat bar  
 $\sphericalangle$  25 x 6 mm

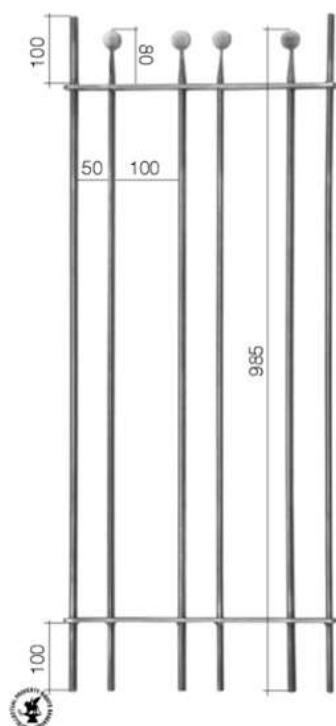

**Art. GD47/1**  
 $\Phi$  12 mm  
 L 420 mm  
 H 1000 mm

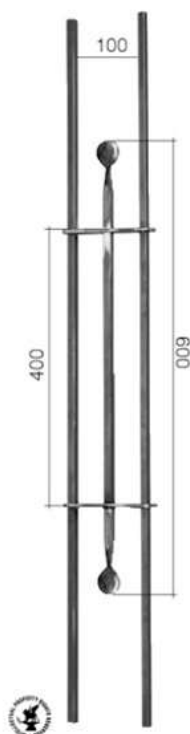

**Art. GD67/1**  
 $\Phi$  12 mm  
 L 125 mm  
 H 1000 mm

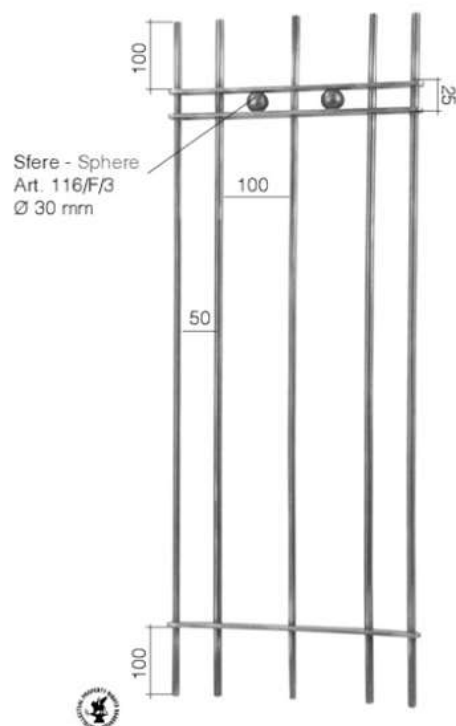

**Art. GD47/3**  
 $\Phi$  12 mm  
 L 360 mm  
 H 1000 mm

Stere - Sphere  
 Art. 116/F/3  
 $\Phi$  30 mm



## Alto valore aggiunto al tuo manufatto finale

Il valore finale della composizione è esponenzialmente più alto rispetto alla somma dei singoli componenti. Un grande risultato, con un grande risparmio.

## High added value to your end product

The final value is exponentially higher than the sum of the individual components.  
A great result, a great saving.



*Le forme organiche e le linee curve  
si fondono con ornamenti a  
predilezione vegetale o floreale.*

*Organic shapes and curved  
lines blend with vegetal or  
floreale ornaments.*

## FLOREAL STYLE



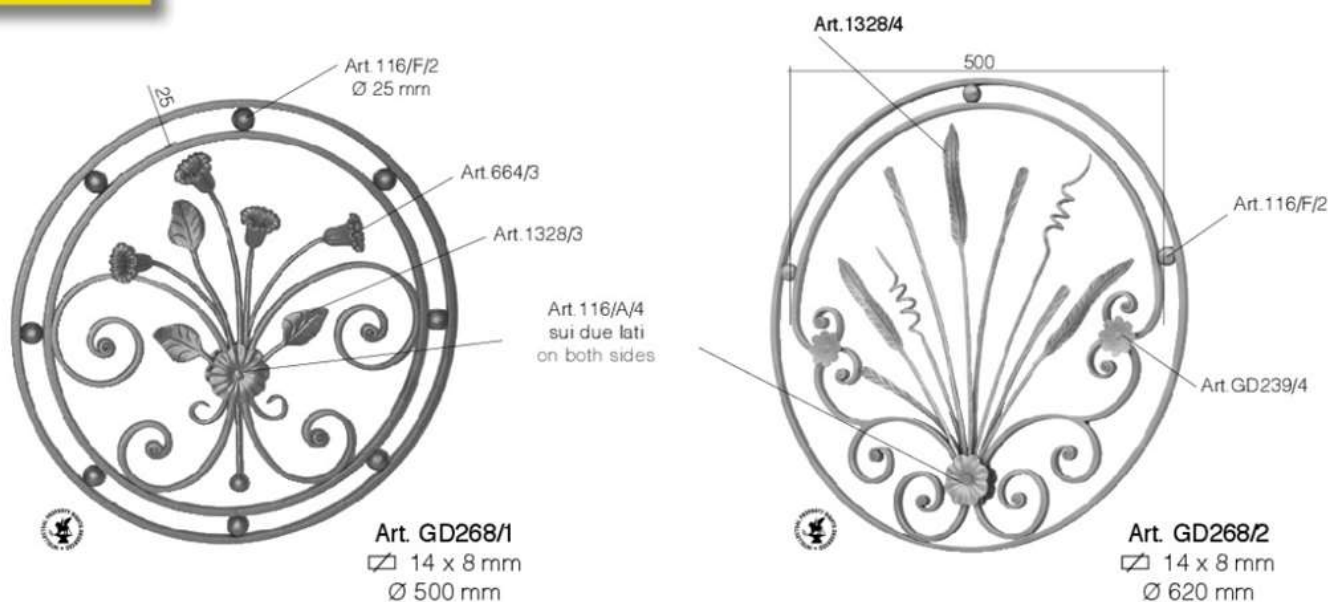

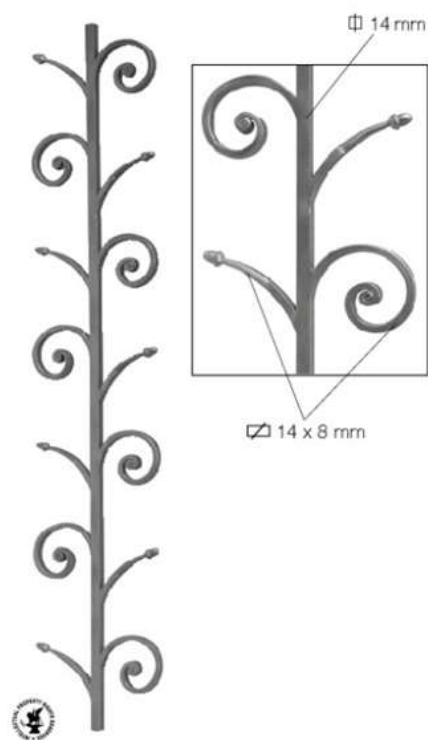

Art. GD176/1  
 $\varnothing$  14 mm  
 L 200 mm  
 H 1000 mm



Art. GD176/2  
 $\varnothing$  14 mm  
 L 200 mm  
 H 1000 mm



Art. GD176/3  
 $\varnothing$  14 mm  
 L 200 mm  
 H 1000 mm

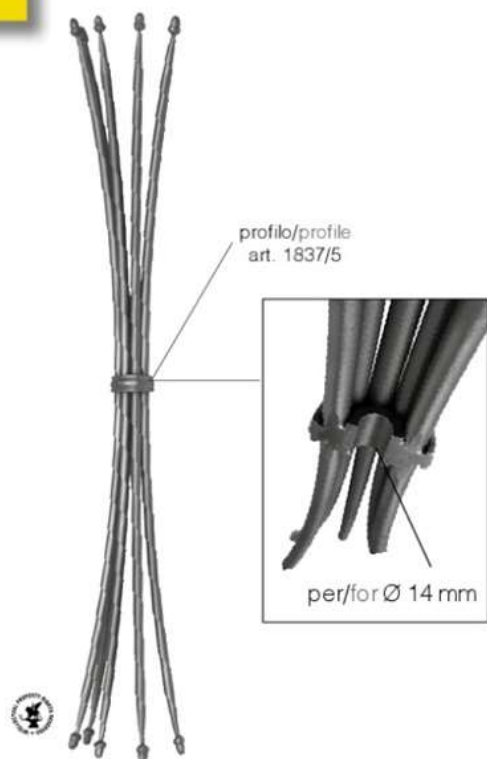

Art. GD253/1  
Ø 12 mm  
L 150 mm  
H 870 mm



Art. GD253/2  
Ø 12 mm  
L 150 mm  
H 500 mm

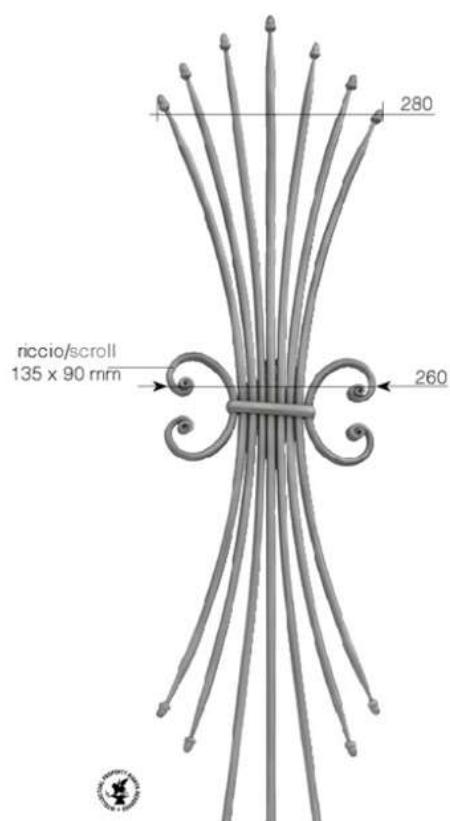

Art. GD255/1  
Ø 12 mm  
L 280 mm  
H 1000 mm

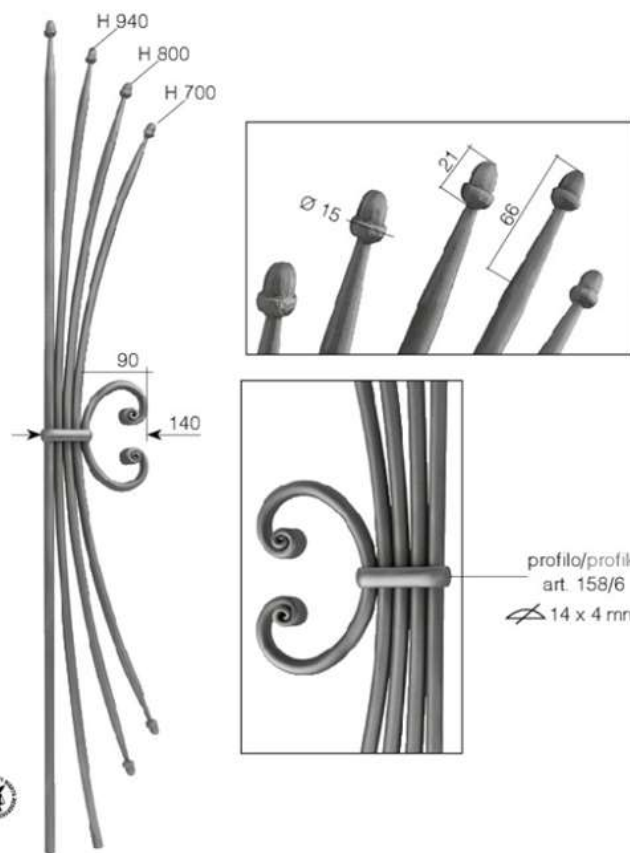

Art. GD255/2  
Ø 12 mm  
L 150 mm  
H 1000 mm



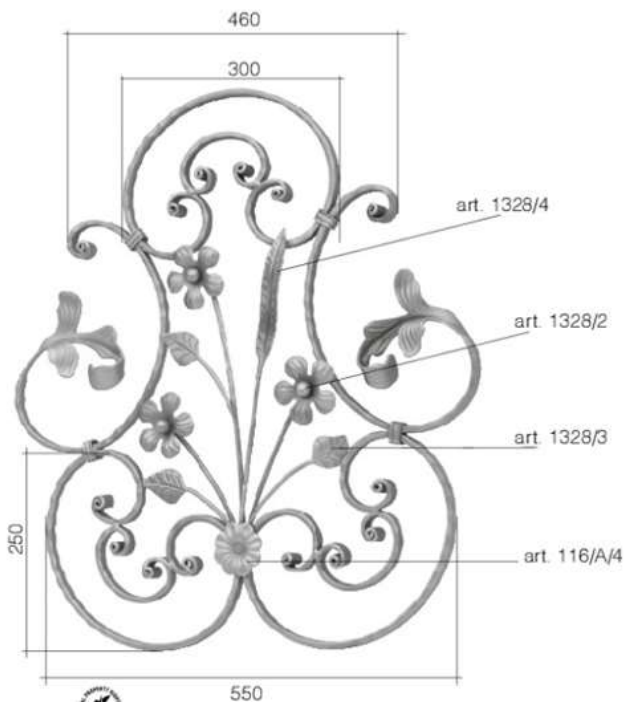

**Art. GD269/1**

▣ 16 x 8 mm spigolato  
hammered on the edges  
640 x 710 mm

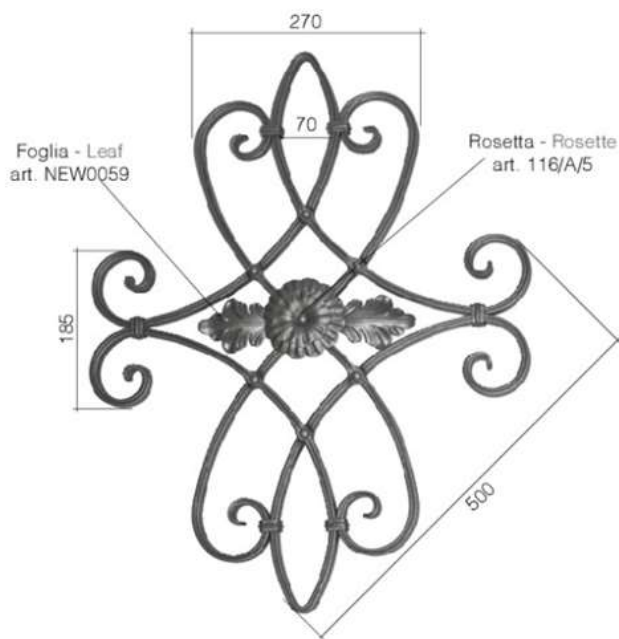

**Art. GD269/2**

▣ 16 x 8 mm  
520 x 665 mm  
Rigato - Grooved

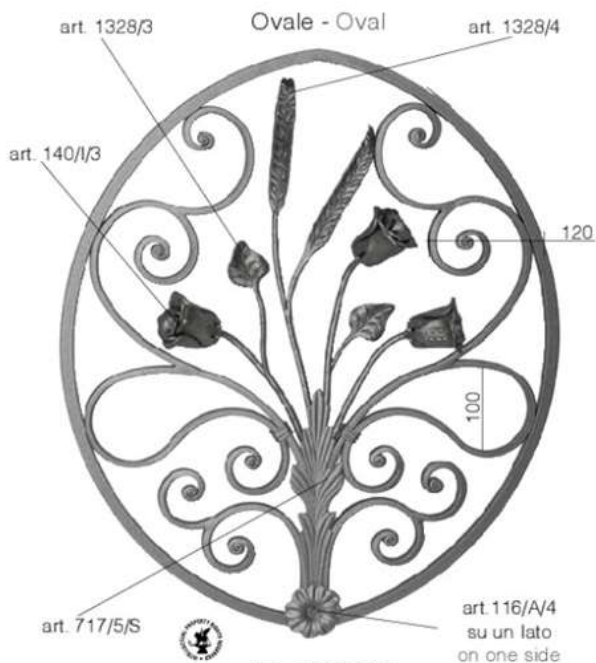

**Art. GD269/3**

⊕ 14 x 14 mm  
600 x 700 mm  
Ricci - Scrolls  
▣ 14 x 8 mm





**Art. GD170/1**  
 Ø 12 mm  
 L 130 mm  
 H 1000 mm

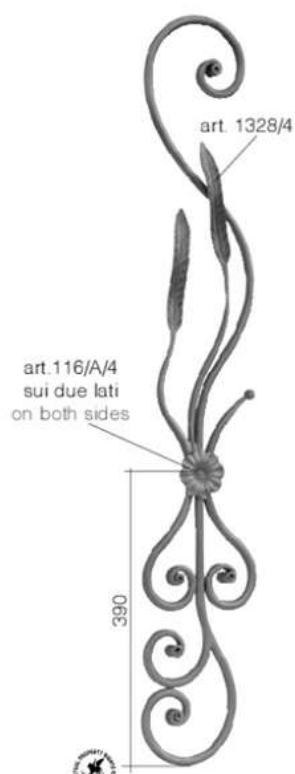

**Art. GD170/2**  
 Ø 12 mm  
 L 170 mm  
 H 1000 mm



**Art. GD202/5**  
 14 x 8 mm  
 L 315 mm  
 H 635 mm

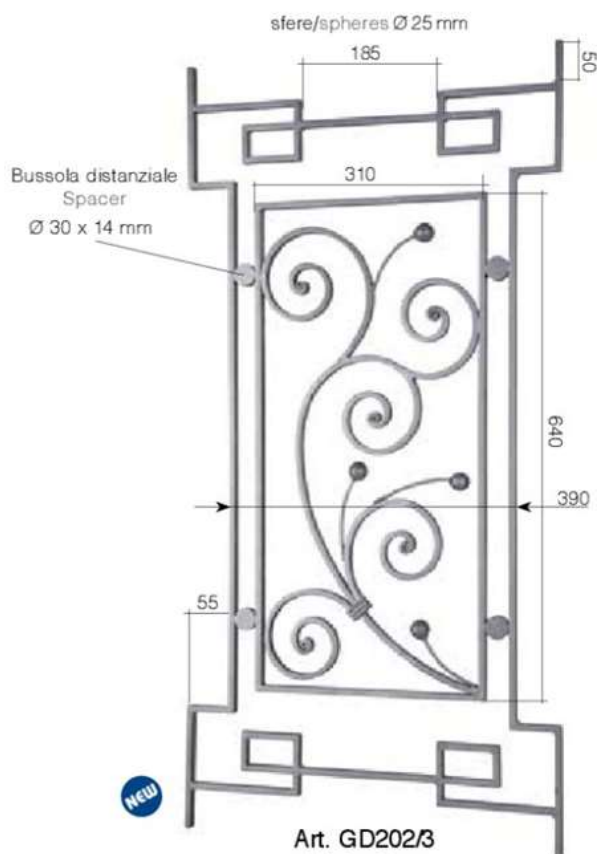

**Art. GD202/3**  
 14 x 8 mm  
 L 500 mm  
 H 1000 mm

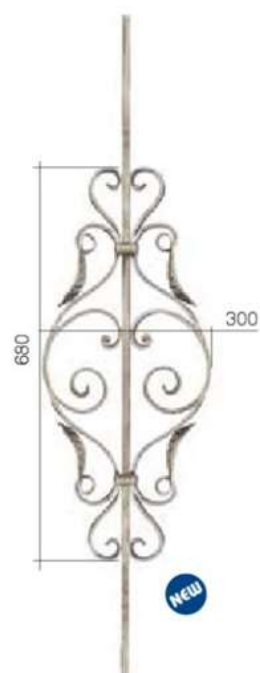
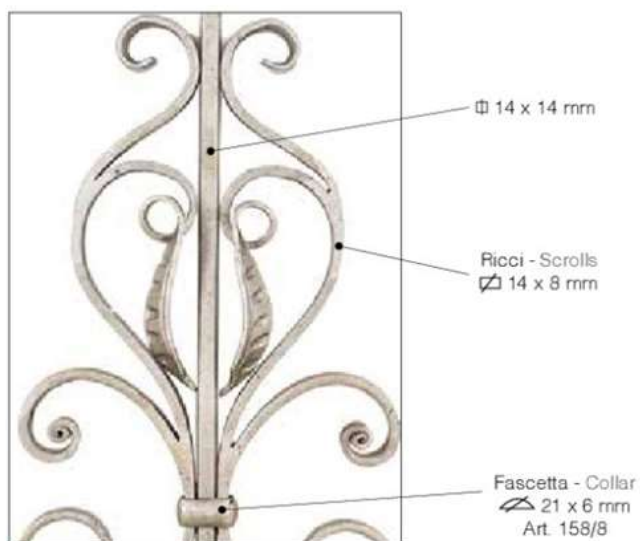

**Art. GD27/1**  
 Ø 14 mm  
 L 300 mm  
 H 1000 mm



**Art. GD27/2**  
 Ø 14 mm  
 L 300 mm  
 H 1000 mm



**Art. GD27/3**  
 Ø 14 mm  
 L 300 mm  
 H 1000 mm



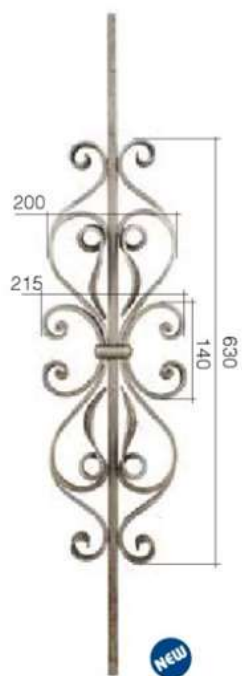

**Art. GD28/1**  
 Ø 14 mm  
 L 215 mm  
 H 1000 mm



**Art. GD28/2**  
 Ø 14 mm  
 L 215 mm  
 H 1000 mm



**Art. GD28/3**  
 Ø 14 mm  
 L 215 mm  
 H 1000 mm

Fascetta - Collar  
 21 x 6 mm  
 Art. 158/8



Ricci - Scrolls  
 14 x 8 mm



Sfere vuote  
Hollow spheres  
Ø 40 mm



**Art. GD92/3**  
Ø 12 mm  
L 100 mm  
H 1000 mm



**Art. GD92/2**  
Ø 12 mm  
L 130 mm  
H 1000 mm

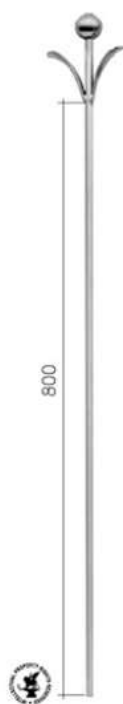

**Art. 1170/3**  
Ø 12 mm  
L 130 mm  
H 1000 mm

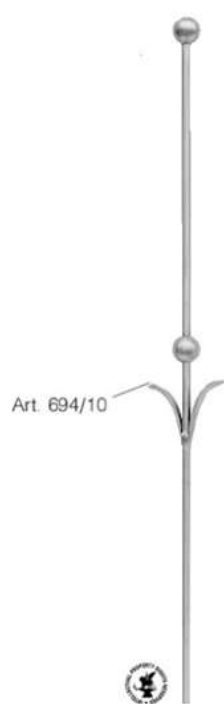

**Art. 1170/4**  
Ø 12 mm  
L 130 mm  
H 1000 mm



**Art. 1170/5**  
Ø 12 mm  
L 70 mm  
H 1000 mm

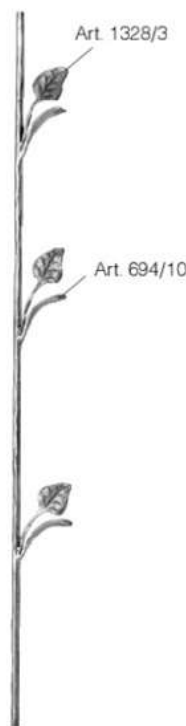

**Art. 1170/6**  
Ø 12 mm  
L 70 mm  
H 1000 mm

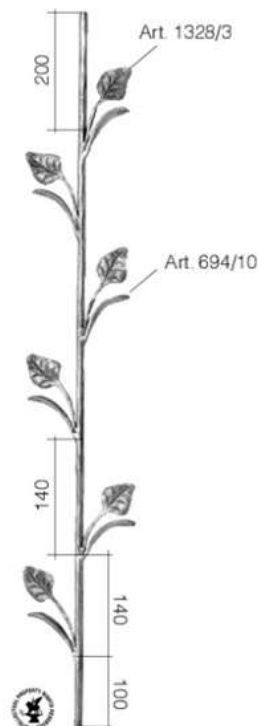

**Art. 1170/1**  
Ø 12 mm  
L 130 mm  
H 1000 mm



Art. 1171/2  
 Ø 12 mm  
 L 60 mm  
 H 1000 mm



Art. 1171/1  
 Ø 12 mm  
 L 120 mm  
 H 1000 mm

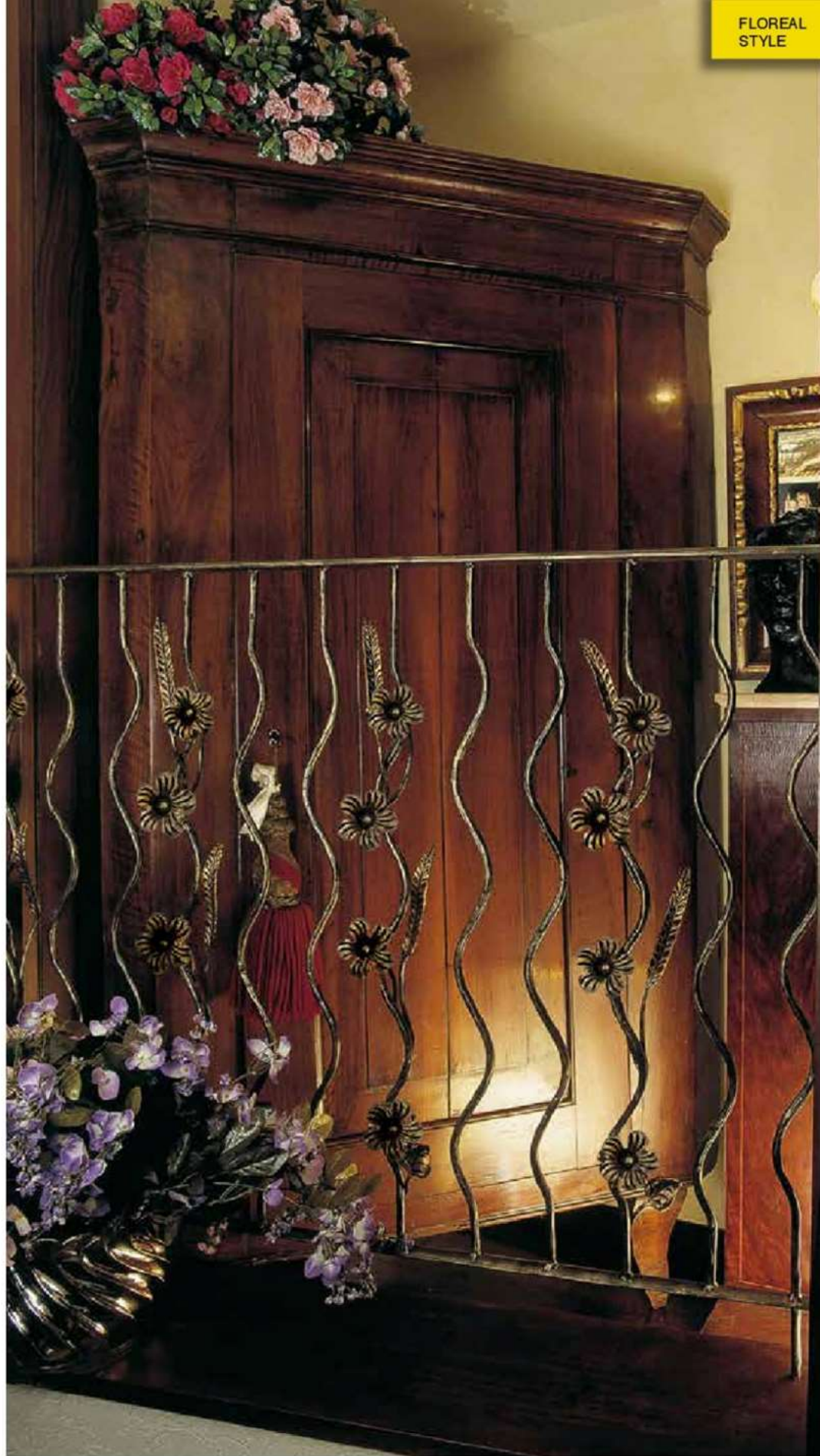



Richiedi il tuo Design su misura!  
Request Your Custom Design!

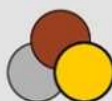

Disponibile nel metallo che vuoi!  
Available in your choice of metal!



Tutti gli articoli Gonzato Design sono disponibili in andamento. Indicaci l'angolo di sviluppo della scala!  
All Gonzato Design articles are available for customisation. Please indicate the angle of the stairs!



Sfere vuote - Hollow spheres Ø 25 mm



Art. 1061/1  
Ø 12 mm  
H 1000 mm  
L 205 mm

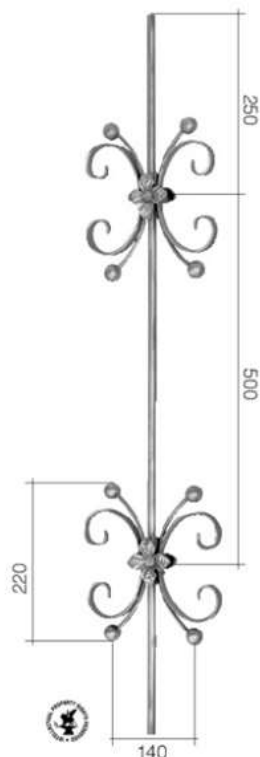

Art. 1061/2  
Ø 12 mm  
H 1000 mm  
L 205 mm

Sfere vuote - Hollow spheres Ø 30, 25 mm



Art. 1060/3  
Ø 12 mm  
H 1000 mm  
L 190 mm

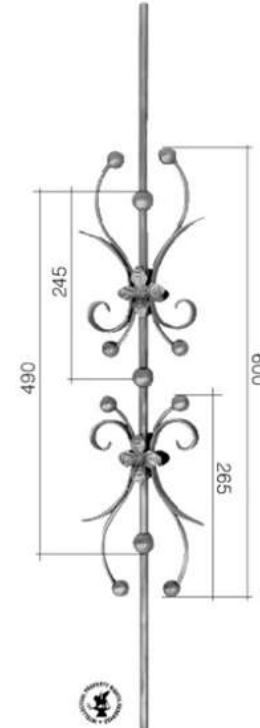

Art. 1060/4  
Ø 12 mm  
H 1000 mm  
L 190 mm



Art. GD222/1  
 ▧ 14 x 8 mm  
 H 1000 mm  
 L 500 mm



Art. GD222/2  
 ▧ 14 x 8 mm  
 H 1000 mm  
 L 500 mm

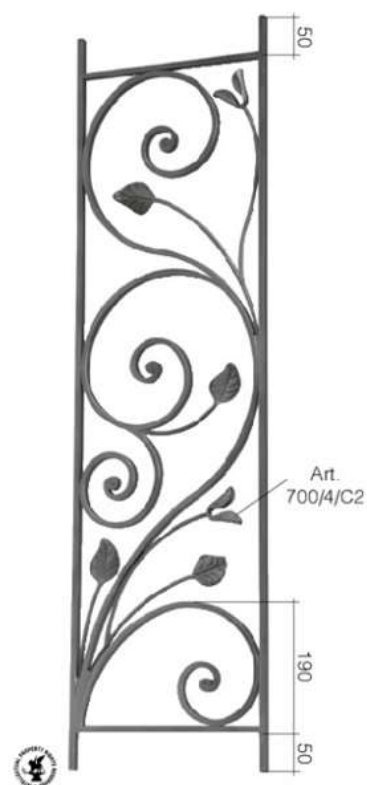

Art. GD223/1  
 ▧ 14 x 8 mm  
 H 1000 mm  
 L 275 mm





Ornamenti / Ornaments  $\varnothing$  14 x 8 mm

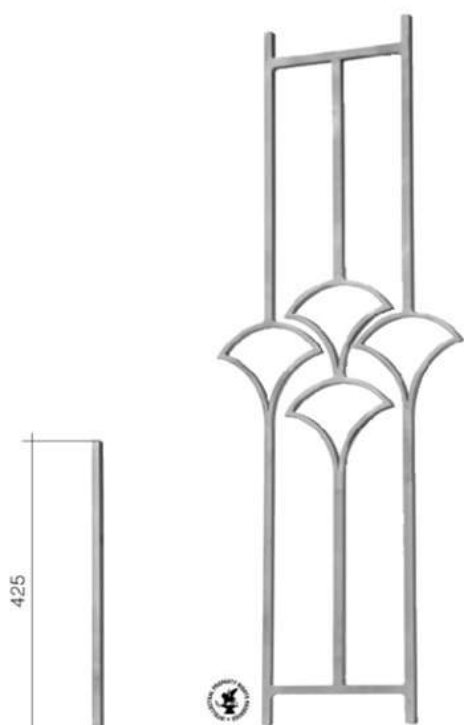

Art. GD186/2  
 $\varnothing$  14 mm  
H 1000 mm  
L 390 mm

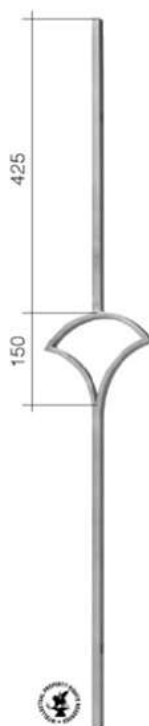

Art. GD186/1  
 $\varnothing$  14 mm  
L 170 mm  
H 1000 mm

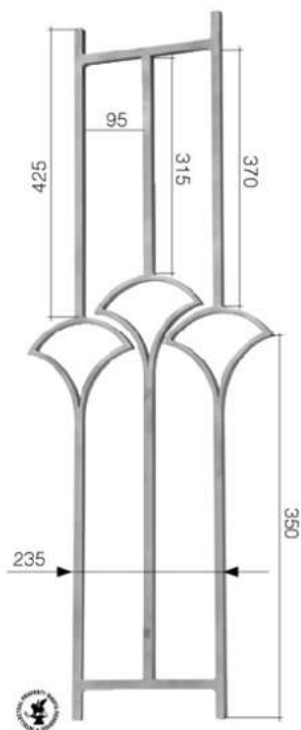

Art. GD186/3  
 $\varnothing$  14 mm  
L 390 mm  
H 1000 mm



Piatti orizzontali  
Horizontal flat bar  
25 x 6 mm

Sfera - Sphere  
Art. 116/F/4 Ø 40 mm

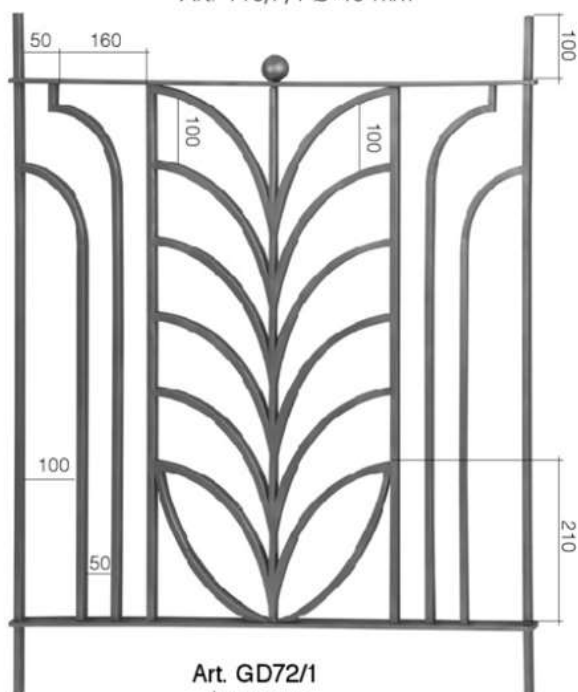

Art. GD72/1  
Ø 12 mm  
L 935 mm  
H 1000 mm

Sfera - Sphere  
Art. 116/F/4 Ø 40 mm

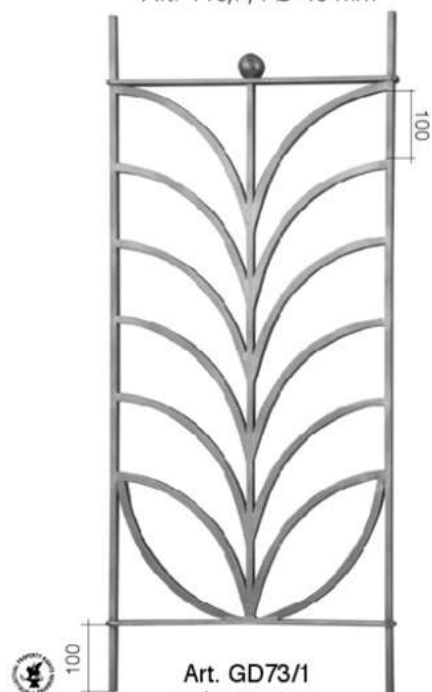

Art. GD73/1  
Ø 12 mm  
L 455 mm  
H 1000 mm



Art. 598/1  
Ø 12 mm  
L 3000 mm

Art. 598/3  
Ø 16 mm  
L 3000 mm

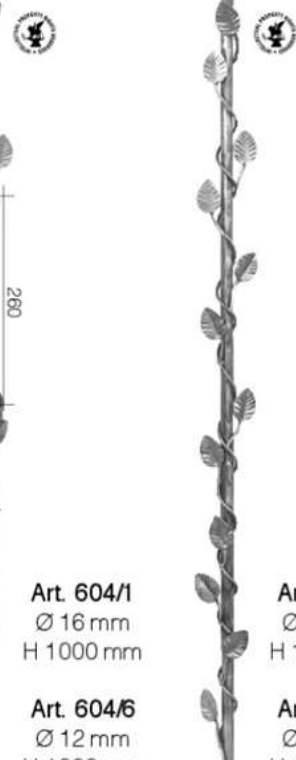

Art. 604/1  
Ø 16 mm  
H 1000 mm

Art. 604/6  
Ø 12 mm  
H 1000 mm



Art. 604/2  
Ø 16 mm  
H 1000 mm

Art. 604/7  
Ø 12 mm  
H 1000 mm



Art. 604/3  
Ø 16 mm  
H 1000 mm

Art. 604/8  
Ø 12 mm  
H 1000 mm



Art. 604/4  
Ø 16 mm  
H 250 mm

Art. 604/9  
Ø 12 mm  
H 250 mm



Art. 604/5  
Ø 16 mm  
H 370 mm

Art. 604/10  
Ø 12 mm  
H 370 mm

