

An Energy Technology Roadmap for Australia

Centralised Generation + Storage + Energy Options

The Transformative Power Plant
v.8.

Jeff Jamieson and Glenn Schumacher





Contents

1

Thinking about the Electricity Supply differently

2

Centralised Generation

3

Understanding the Challenge

4

Storage

5

Technology Concepts 1 to 10

6

Background Information

Introduction



Thinking About
Electricity Supply
Differently

Australia IS Facing An Energy Crisis

By any metric Australia is facing an Energy Crisis. Australian energy (Electricity and Gas) prices continue to increase whilst the decline in demand would appear to have stabilised even with significant price increases and higher penetration of Roof Top Solar PV. Any further reduction in demand may well be a result of declining industrial use due to industry closure potentially leading to economic downturn.

In terms of Electricity, whilst there are a number of complex factors (such as Grid stability etc), the basic issue remains one of matching Supply and Demand.

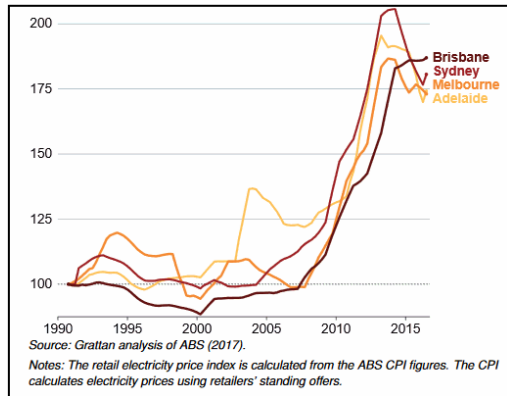

This paper is intended to explore potential means of increasing supply.

NEM Retail electricity price history – Index of real retail electricity prices rolling four-quarter average 100 = December 1990

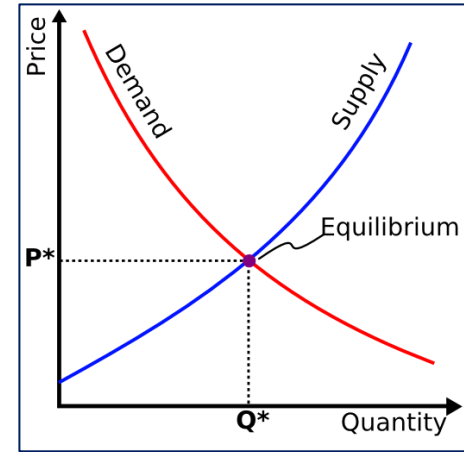

The basic Economics Law of Supply and Demand

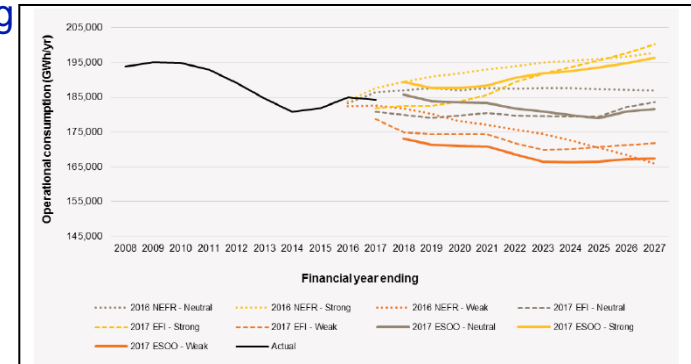

NEM annual consumption by scenarios, AEMO 2017 Electricity Statement Of Opportunities

Thinking About The Future Of Central Generation

In thinking about increasing Electricity supply, we should take a systematic view of the future of the Grid and Centralised Generation, we started considering four areas :

Energy Sources / "Prime Movers"

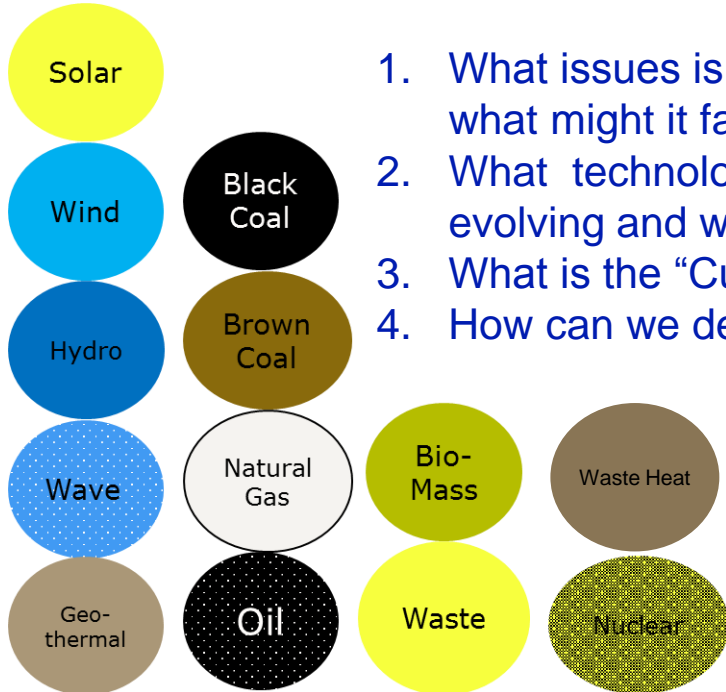

1. What issues is "The Grid" currently facing and what might it face,
2. What technologies are we using now, what is evolving and what might be in the future,
3. What is the "Customer" looking for,
4. How can we design solutions to the above.

Key in this analysis was a basic consideration of what the primary Energy Sources / "Prime Movers" are and how can we utilize them.

Conversion Technologies



Background



Centralised Generation

Central Generation + Storage ?

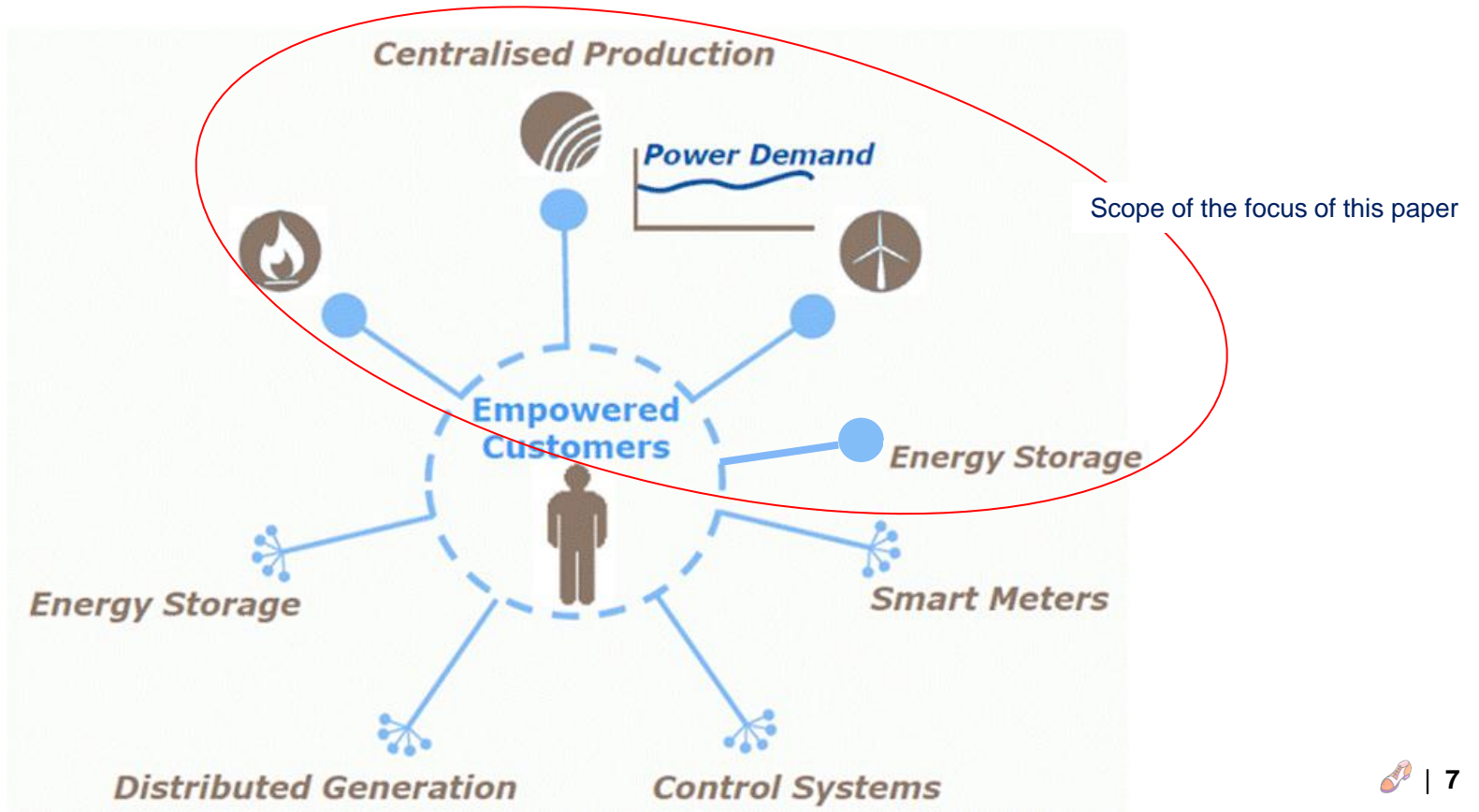

Considering the Future Of Central Generation

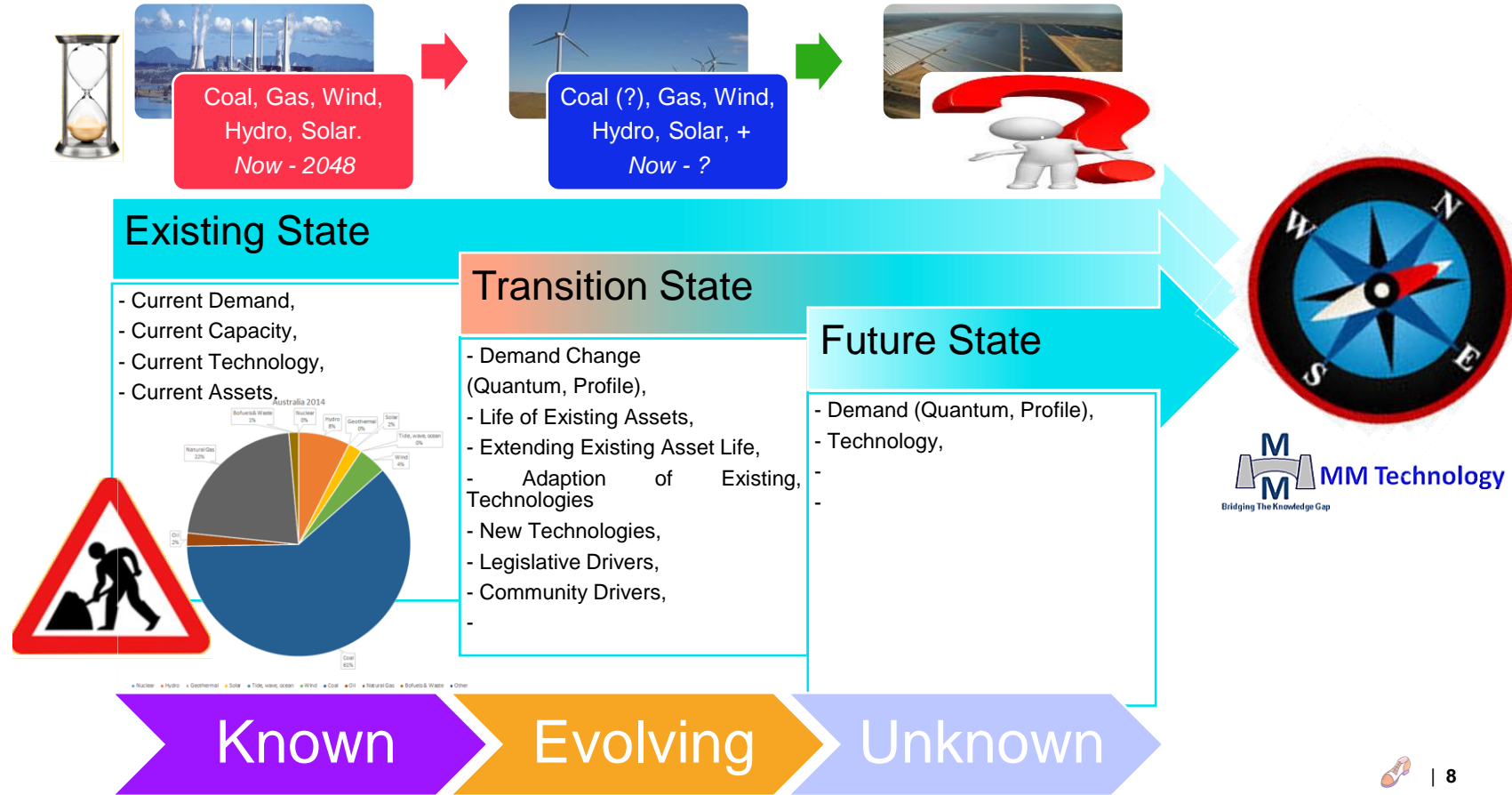

The Existing State

Australian Electricity by Fuel

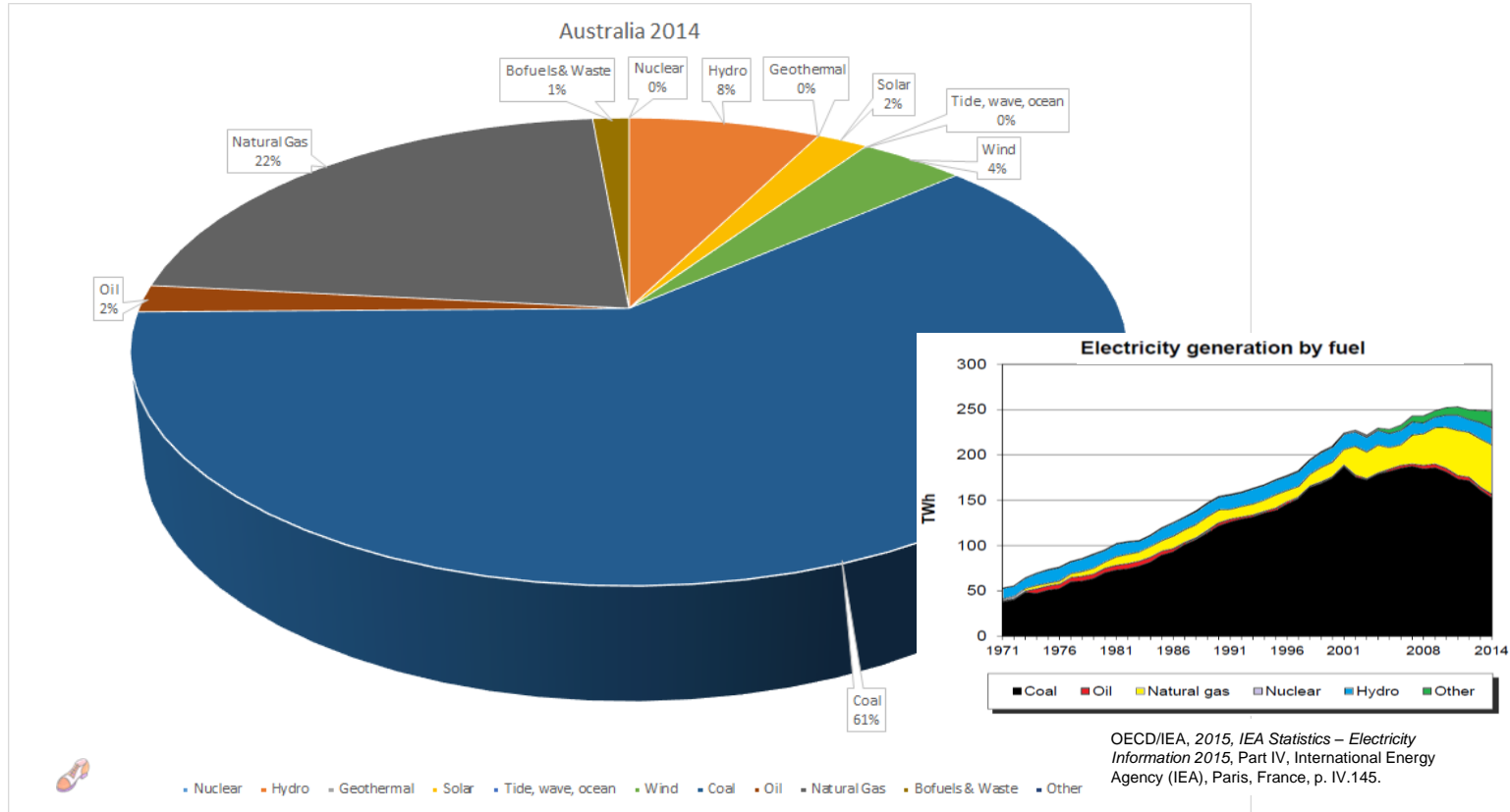

■ Nuclear ■ Hydro ■ Geothermal ■ Solar ■ Tide, wave, ocean ■ Wind ■ Coal ■ Oil ■ Natural Gas ■ Bofuels & Waste ■ Other



Foreseeing the Future of Central Generation

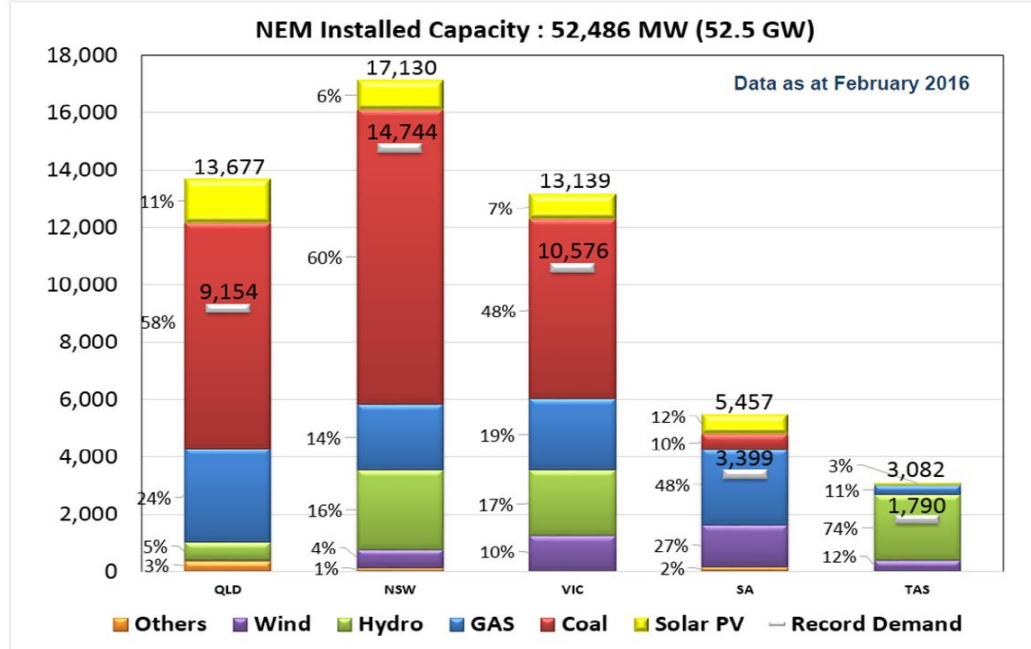

Others = Biomass + Geothermal + other fuel sources (summer capacities sourced from [AEMO Generation Information as of Oct 2015](#))

*Solar PV (estimate) obtained from the [National Electricity Forecasting Report \(June 2015\)](#)

Tasmania Record Demand occurred in Winter 21 Jul 2008

“The best way to predict your future is to create it!”

Abraham Lincoln – February 1809 to April 1865, 16th U.S. President.



We Cannot Assume The Current Situation Will Persist



We Cannot Assume The Current Situation Will Persist

“It is not necessary to change.
Survival is not mandatory.”

Dr. William Edwards Deming (October 14, 1900 – December 20, 1993), American statistician, professor, author, lecturer and consultant. He is perhaps best known for his work in teaching management how to improve design (and thus service), product quality, testing, and sales.

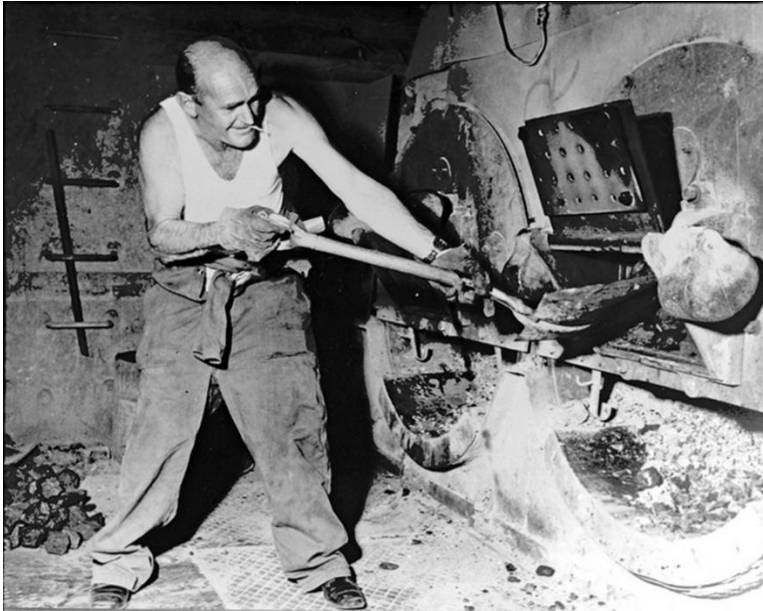

Stoking the boilers aboard the Newcastle to Stockton Ferry, Newcastle, NSW., circ. 1970.

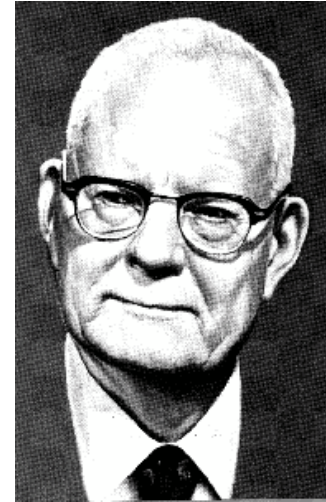

Is There Going To Be Any Need For Central Generation ?

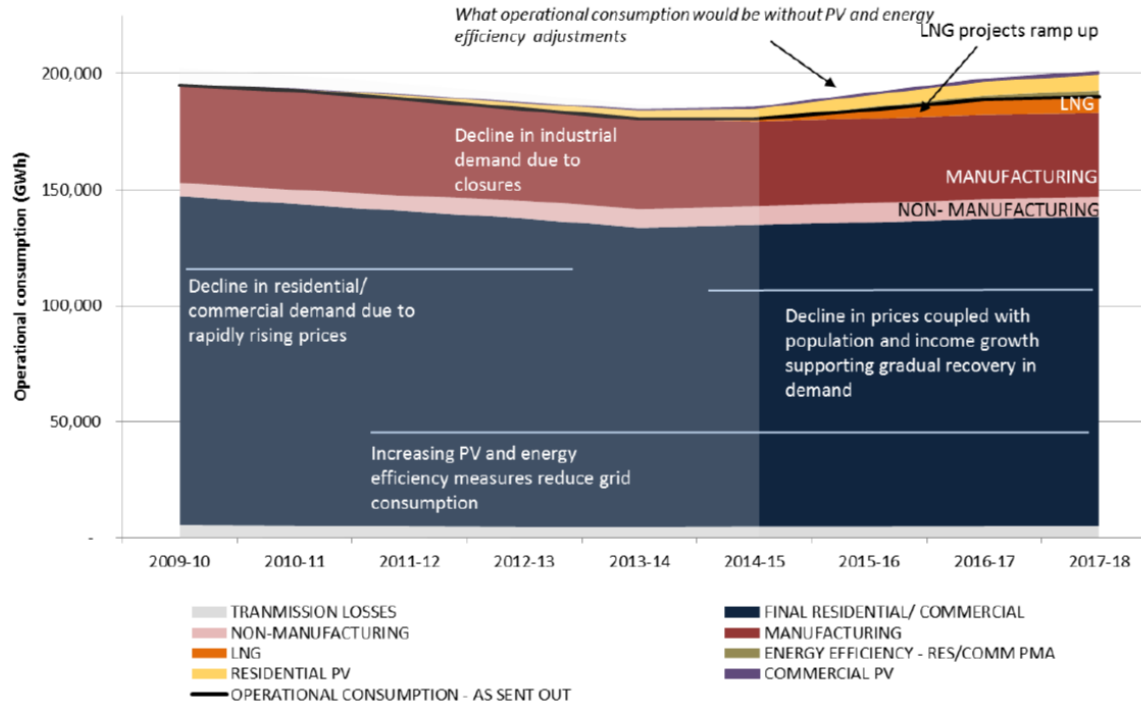

NEM operational consumption by key component to 2012 - 2018

Source : AEMO, 2015, 'Update National Electricity Forecasting Report For The National Electricity Market', December 2015, Australian Energy Management Company (AEMO), Melbourne, p. 8.



Is There Going To Be Any Need For Central Generation ?

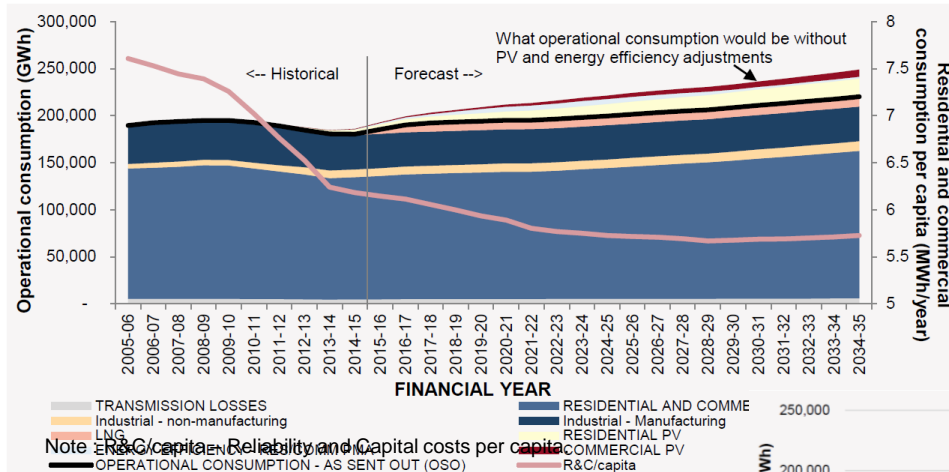

NEM operational consumption by key component to 2034 - 2035

Comparison of NEM historical and forecast operational consumption

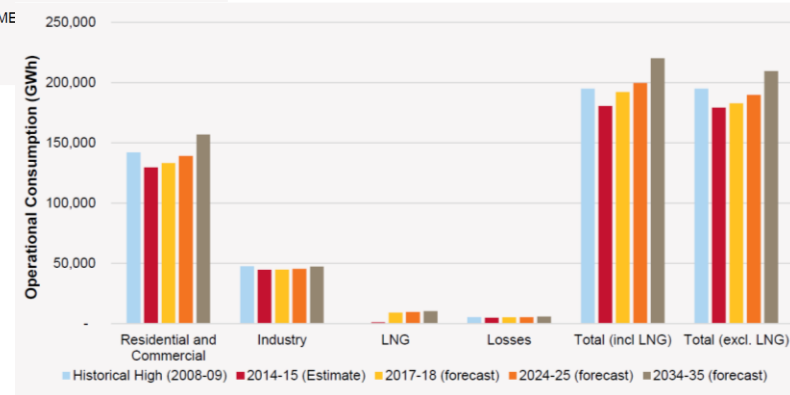

Centralised Generation Does Not Appear To Be Going Away !

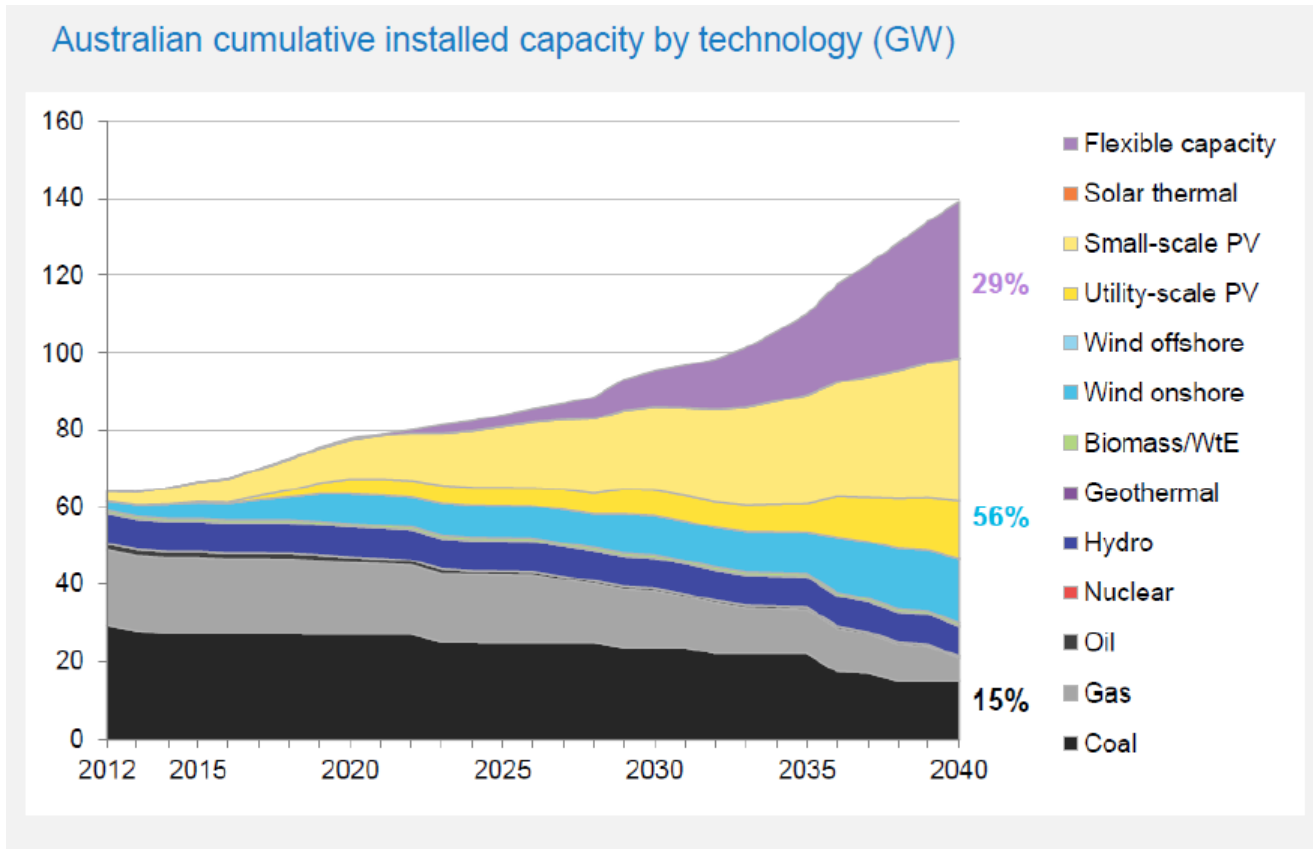

Source : Bloomberg New Energy Finance (BNEF), 2015, 'New Energy Outlook 2015', Bloomberg Finance L.P., New York.





The Evolving Challenge

Understanding The
Challenge

Sustainability – A Key For Central Generation

...“sustainable development is development that meets the needs of the present without compromising the ability of future generations to meet their own needs ...” (Brundtland

Commission of the United Nations on March 20, 1987.)

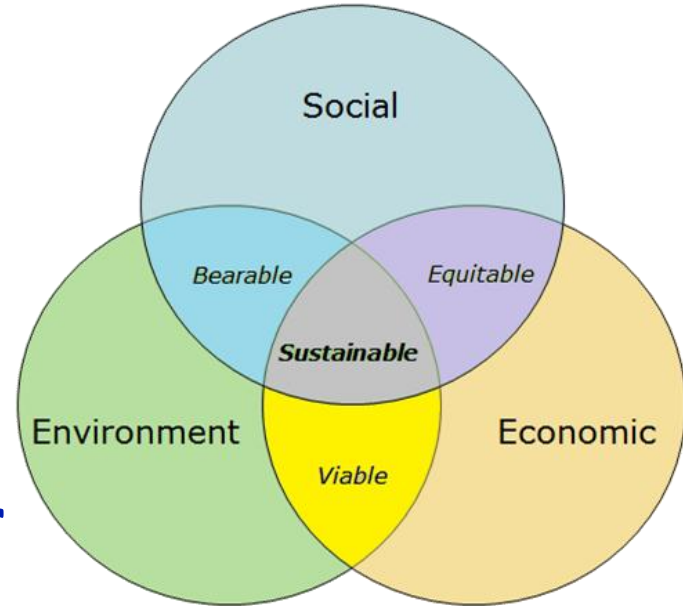

Is There Going To Be Any Need For Central Generation ?

Value Proposition Canvas

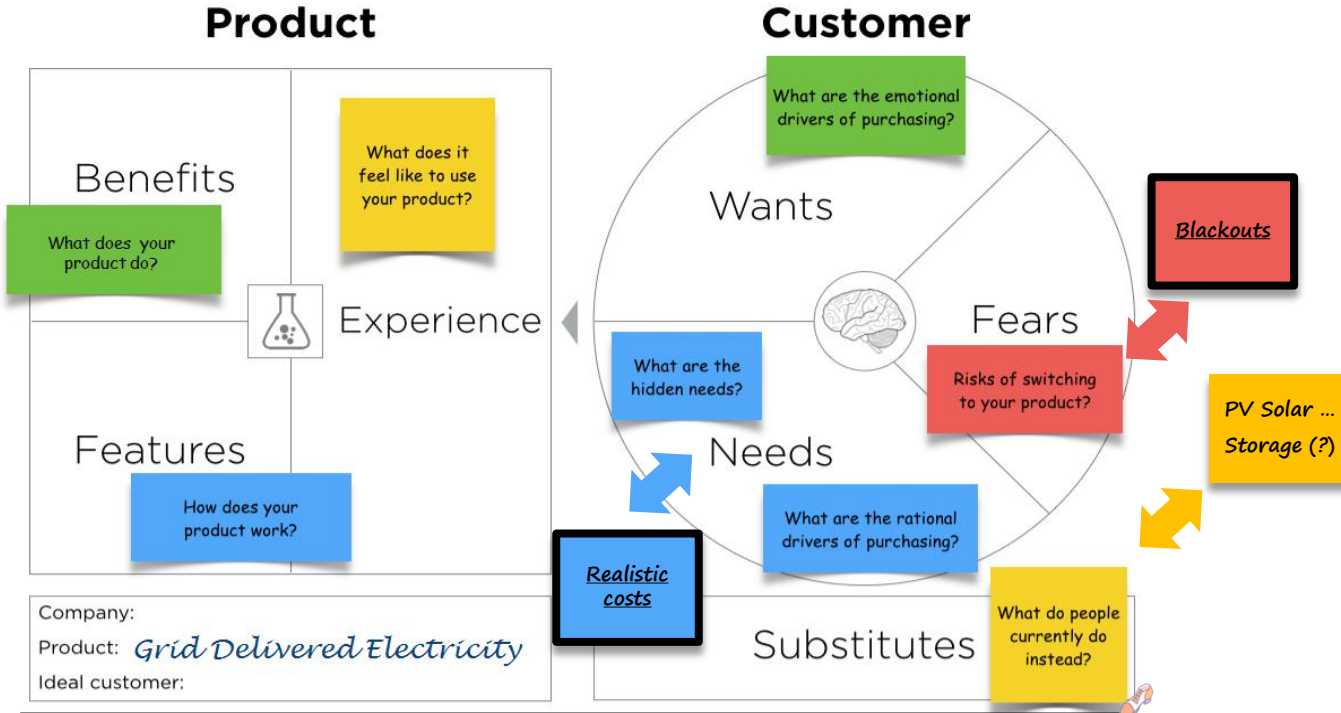

Failure to meet the Customers Needs and allay their Fears may see our Industries' Social License to Operate evaporate

Is There Going To Be Any Need For Central Generation ?

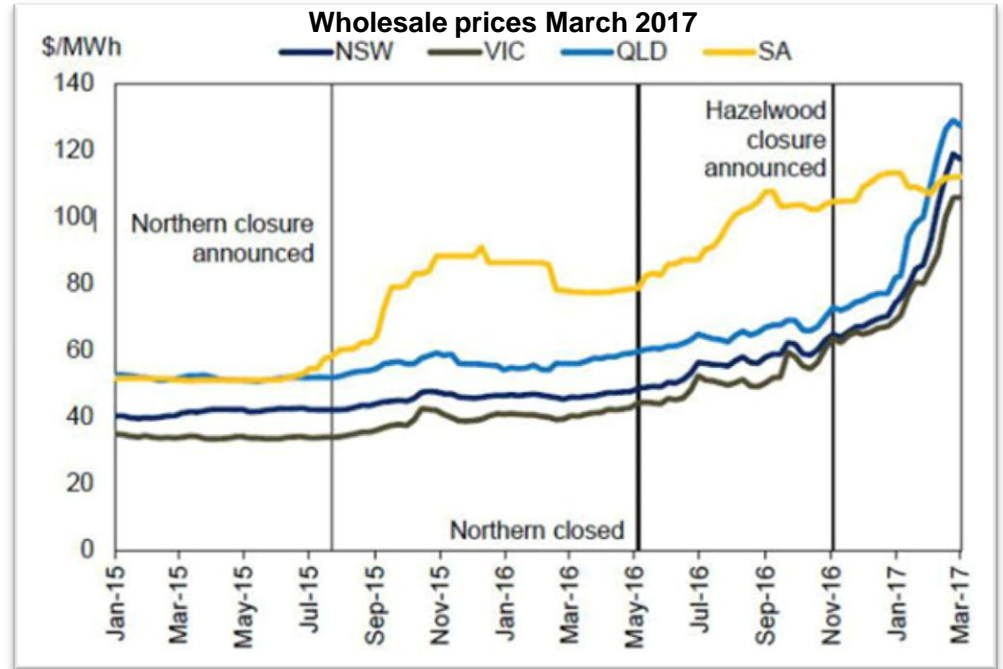
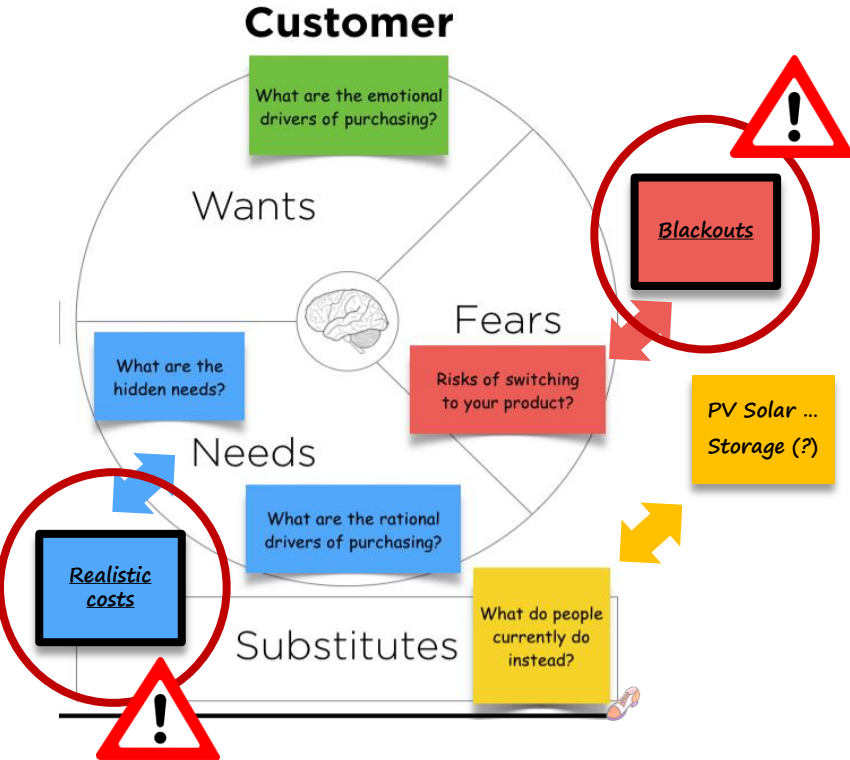

*Failure to meet the Customers Needs and allay their Fears may see our Industries' **Social License to Operate** evaporate*

Thinking About Central Generation

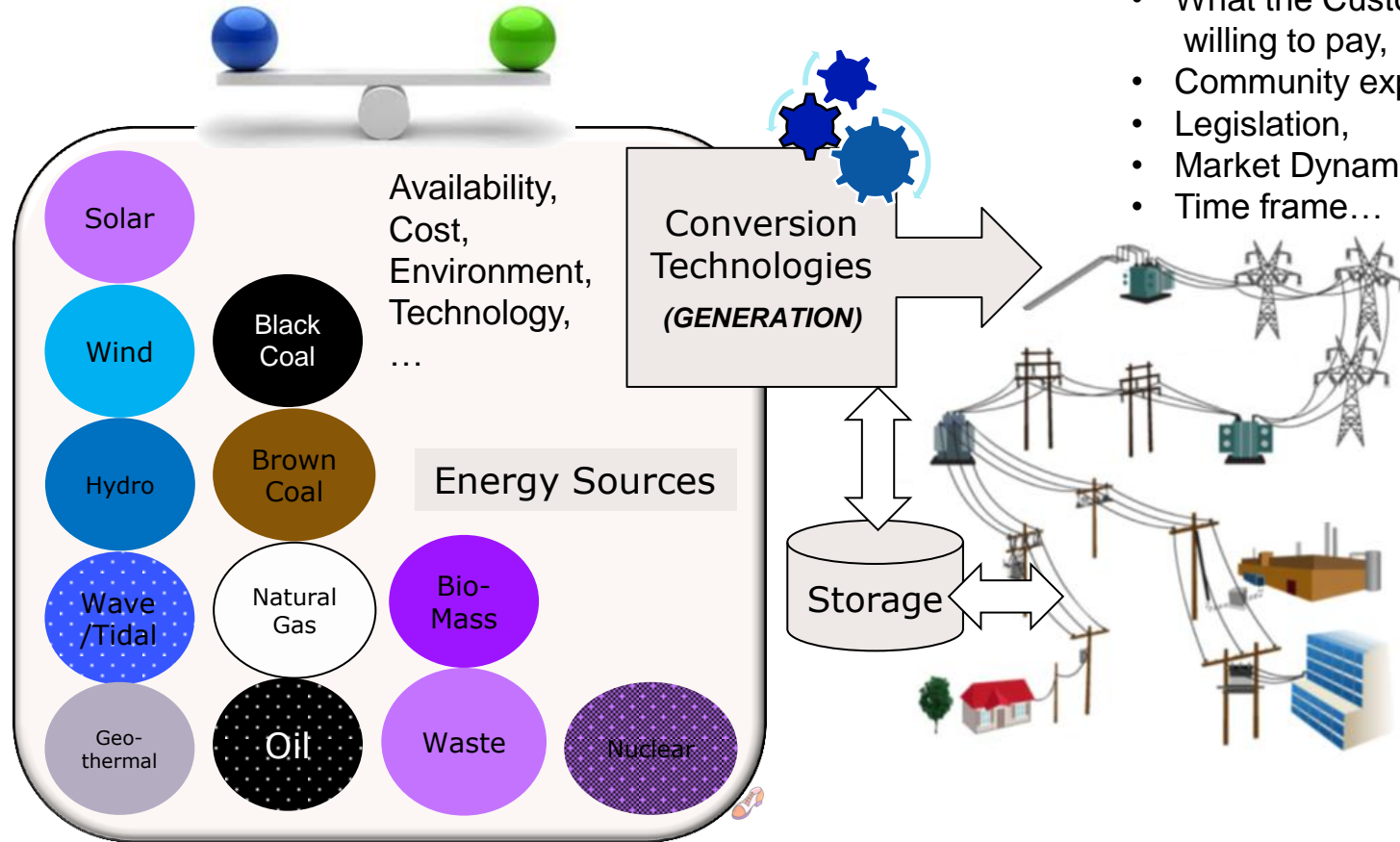

- Demand quantum,
- Demand cycle,
- What the Customer is willing to pay,
- Community expectations,
- Legislation,
- Market Dynamics,
- Time frame...



Foreseeing The Future Of Central Generation

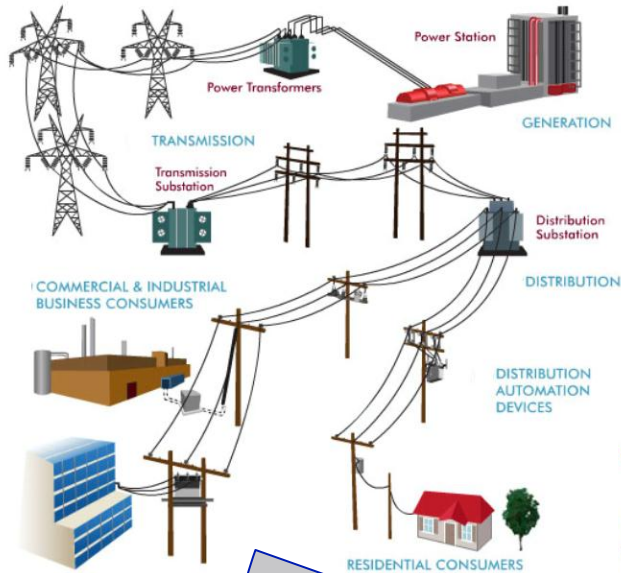

Traditional Grid



The evolution of the Grid (driven by technology and the Customer) will drive what the role of Centralised Generation will be, how we will transform to the new demands and what technologies and characteristics will be appropriate.

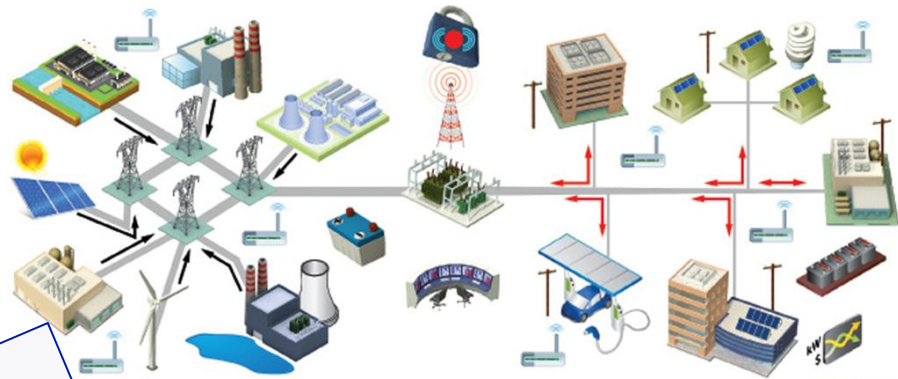

The 'Evolving' Grid

© 2015 Electric Power Research Institute, Inc. All rights reserved.



There Is A Problem !

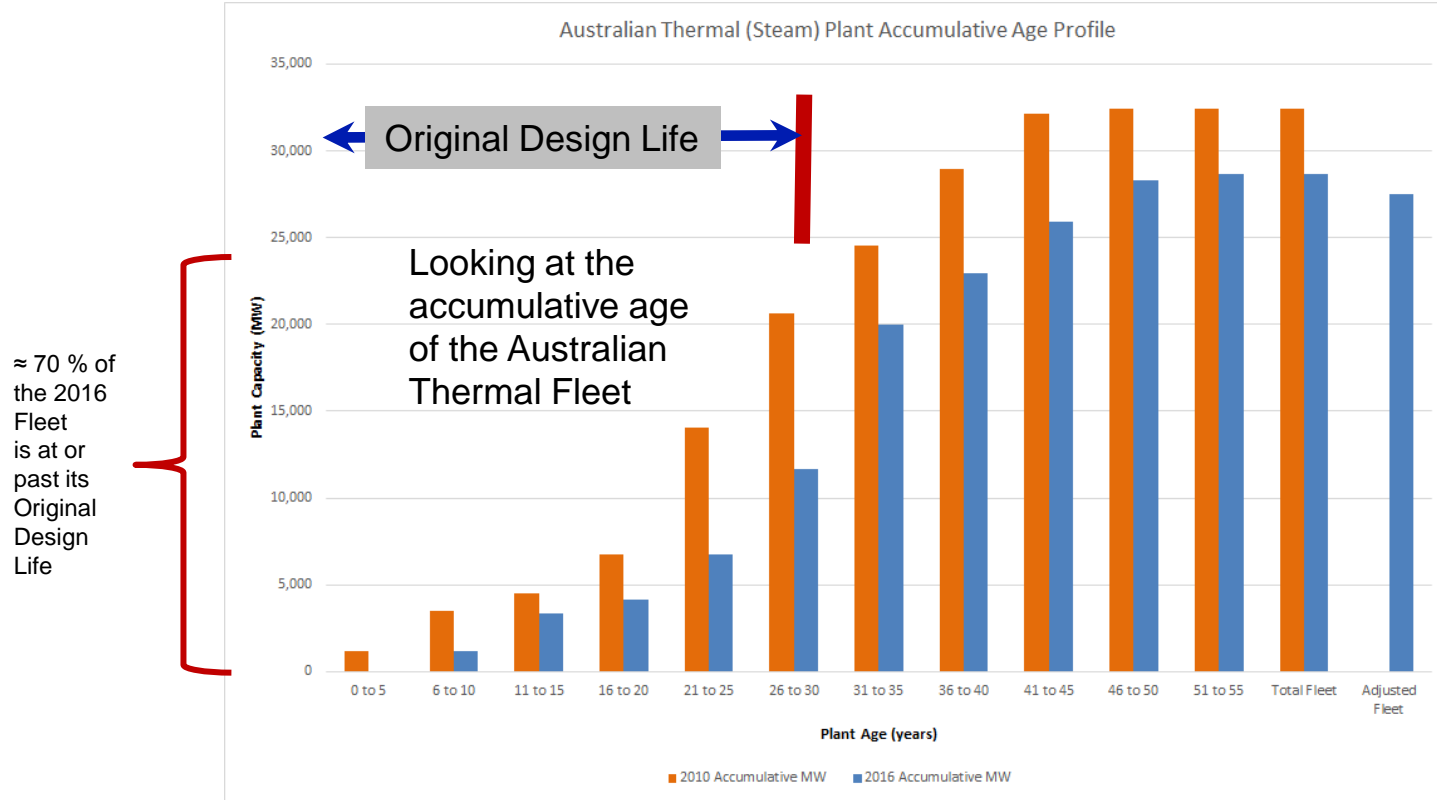

Typical Thermal Plant Design Life ≈ 200,000 Hours of Operation
 which equates to 25 to 30 Years of Base Load Operation

Source : The Community of Practice for Coal Utilisation, "2016 Plant Database", The Community of Practice for Coal Utilisation, Brisbane.
 Used with permission.



There Is A Problem !

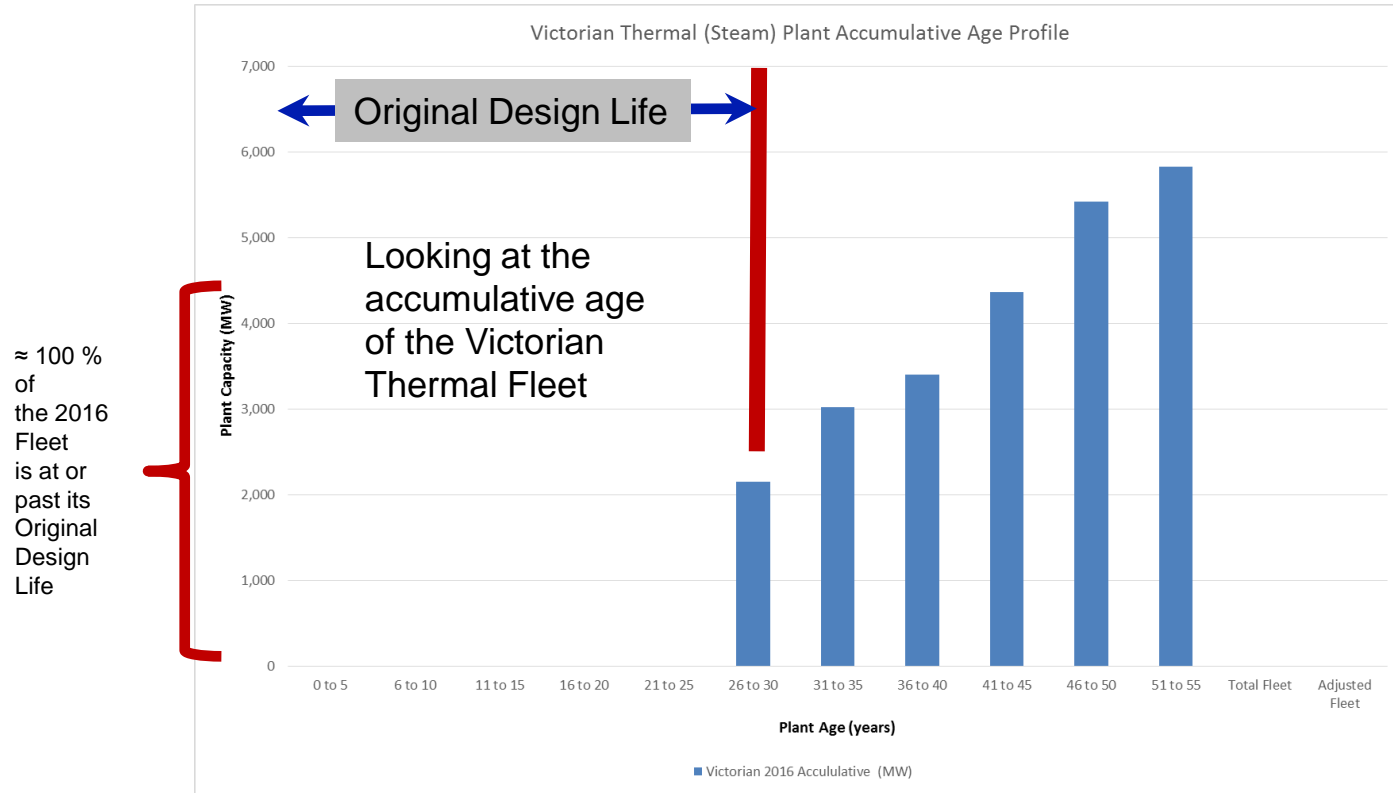

Typical Thermal Plant Design Life ≈ 200,000 Hours of Operation
which equates to 25 to 30 Years of Base Load Operation

Source : The Community of Practice for Coal Utilisation, "2016 Plant Database", The Community of Practice for Coal Utilisation, Brisbane.
Used with permission.



NEM South Australian Region – A Live Case Study

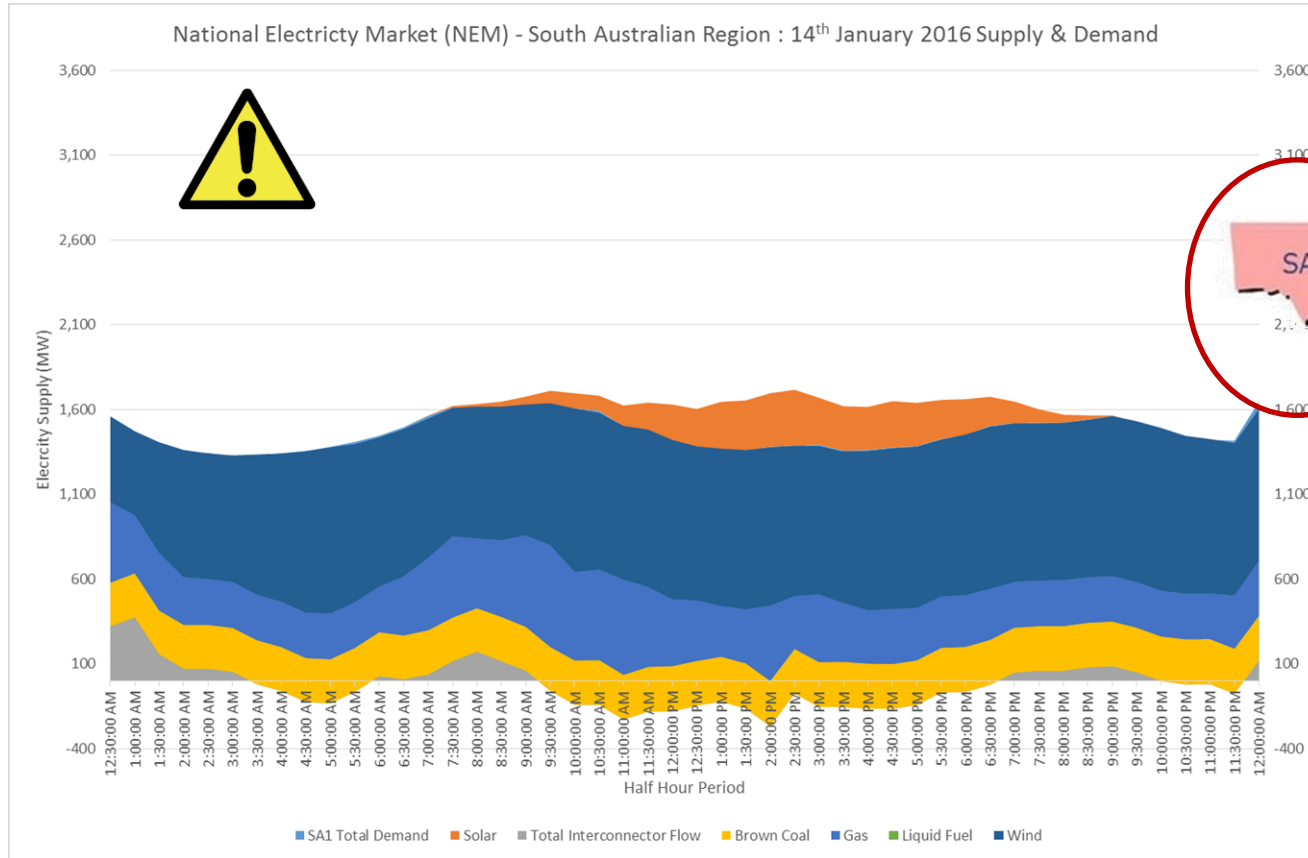

'A day in the life of the South Australian Market !'



NEM South Australian Region – A Live Case Study

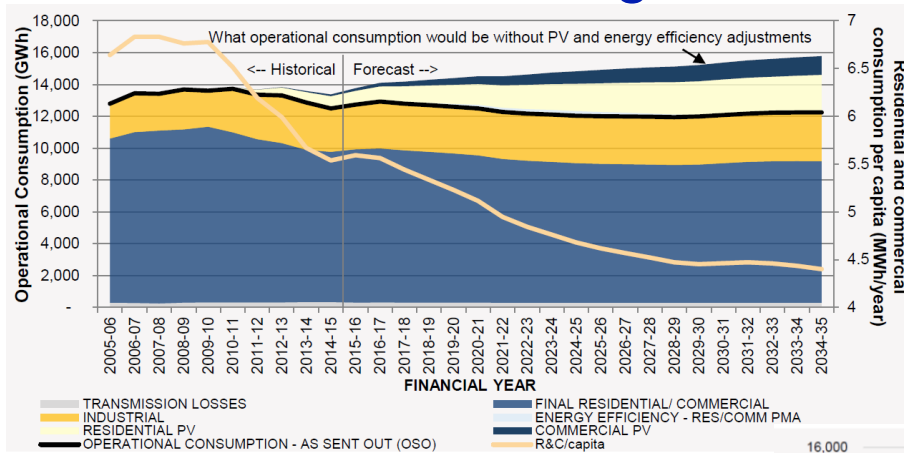

Summary of operational consumption by key component in South Australia

Comparison of actual and forecast operational consumption in South Australia

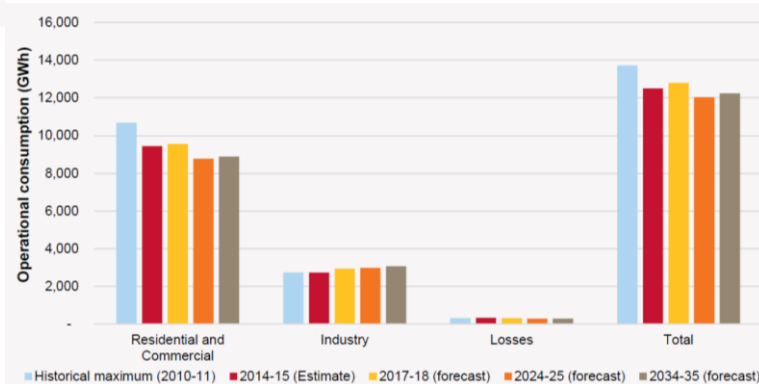

NEM South Australian Region – A Live Case Study

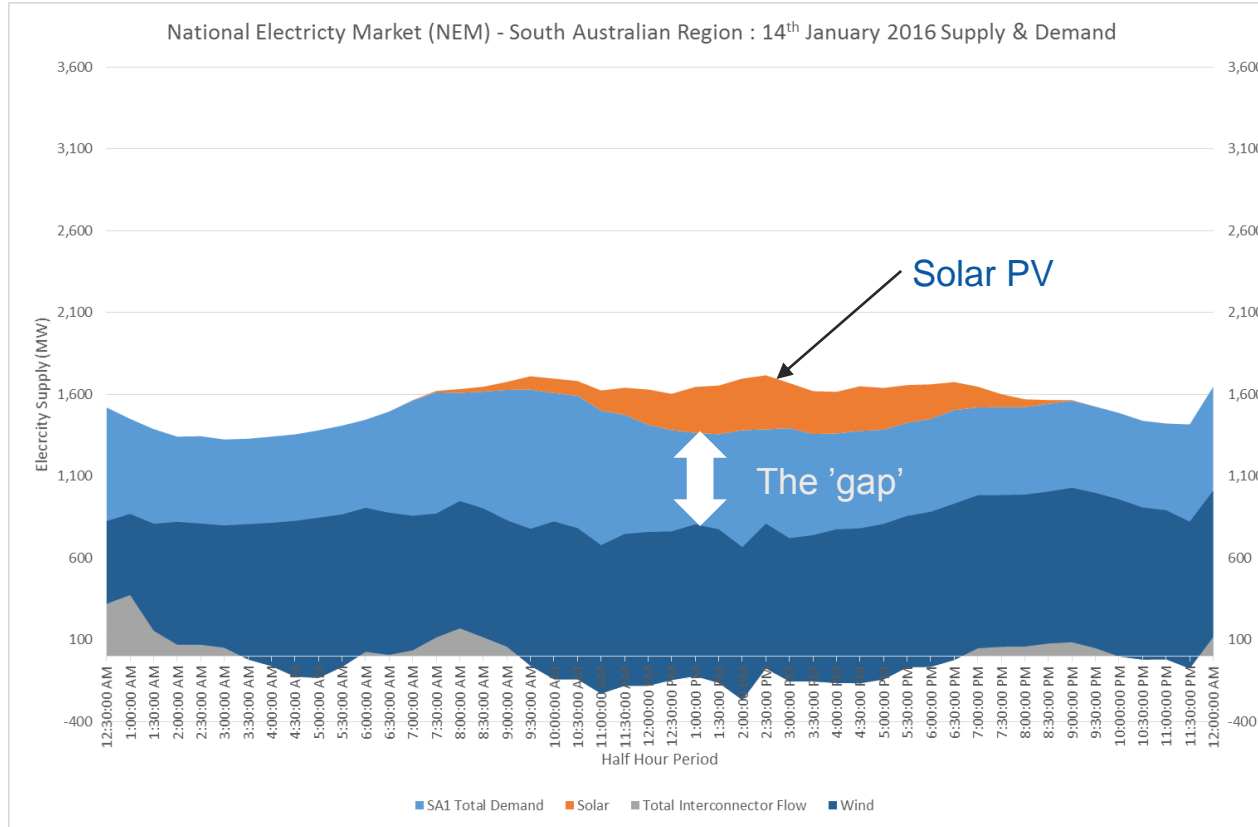

NEM South Australian Region – A Live Case Study

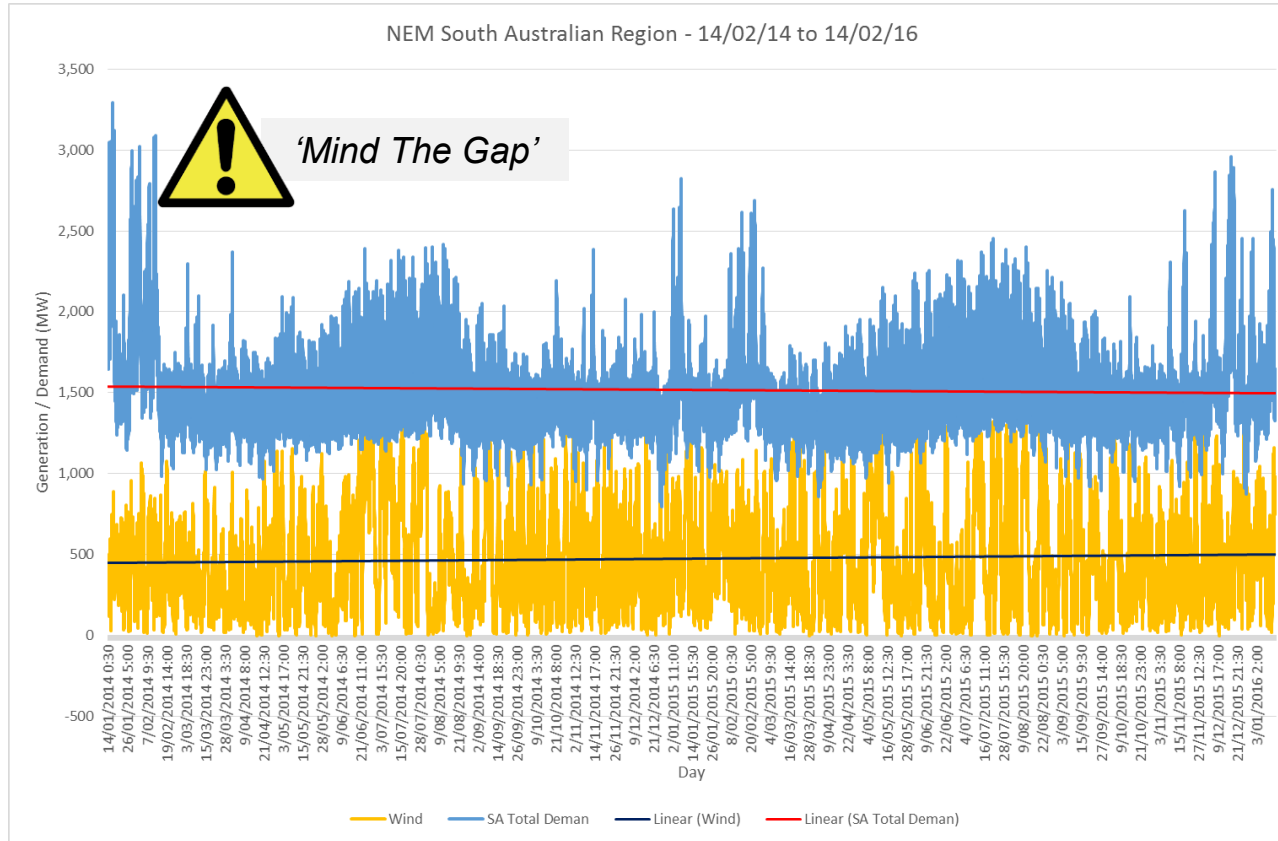

NEM South Australian Region – A Live Case Study

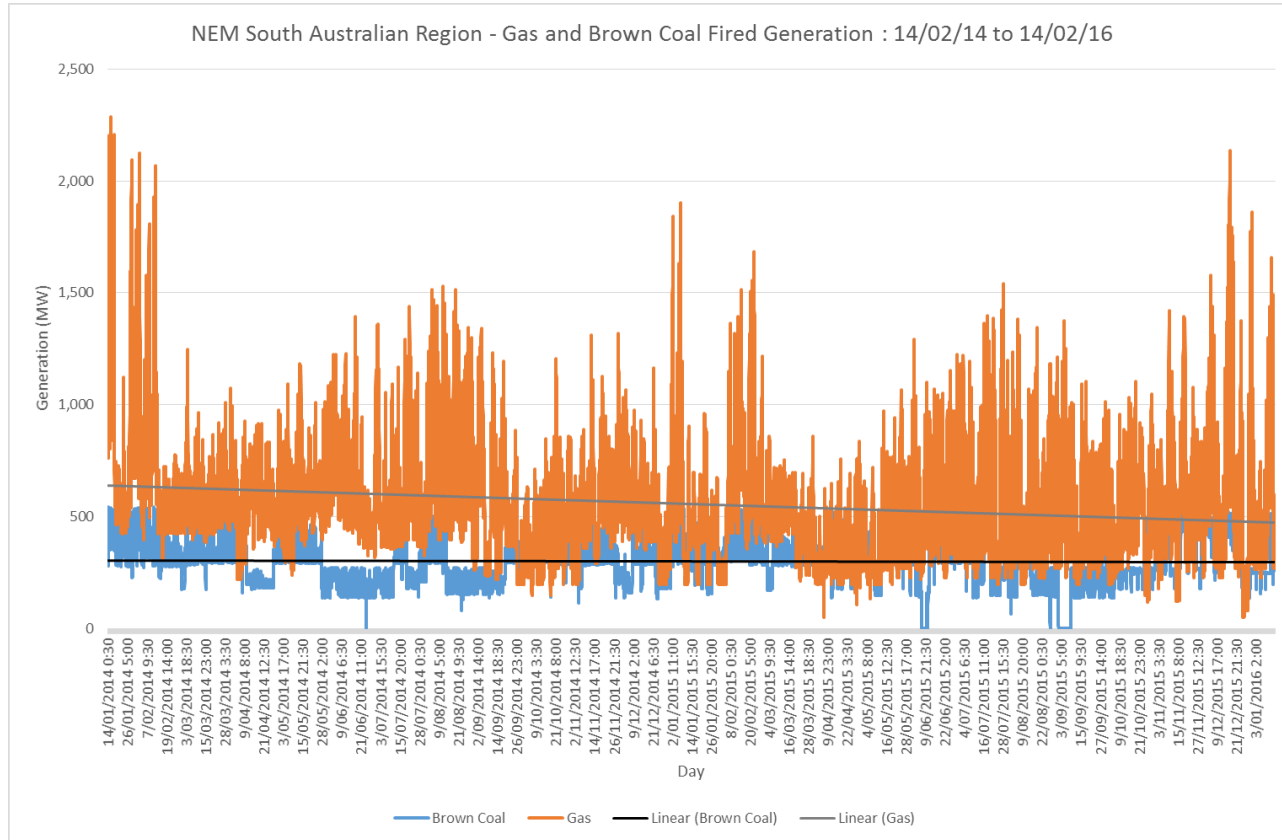

NEM South Australian Region – A Live Case Study

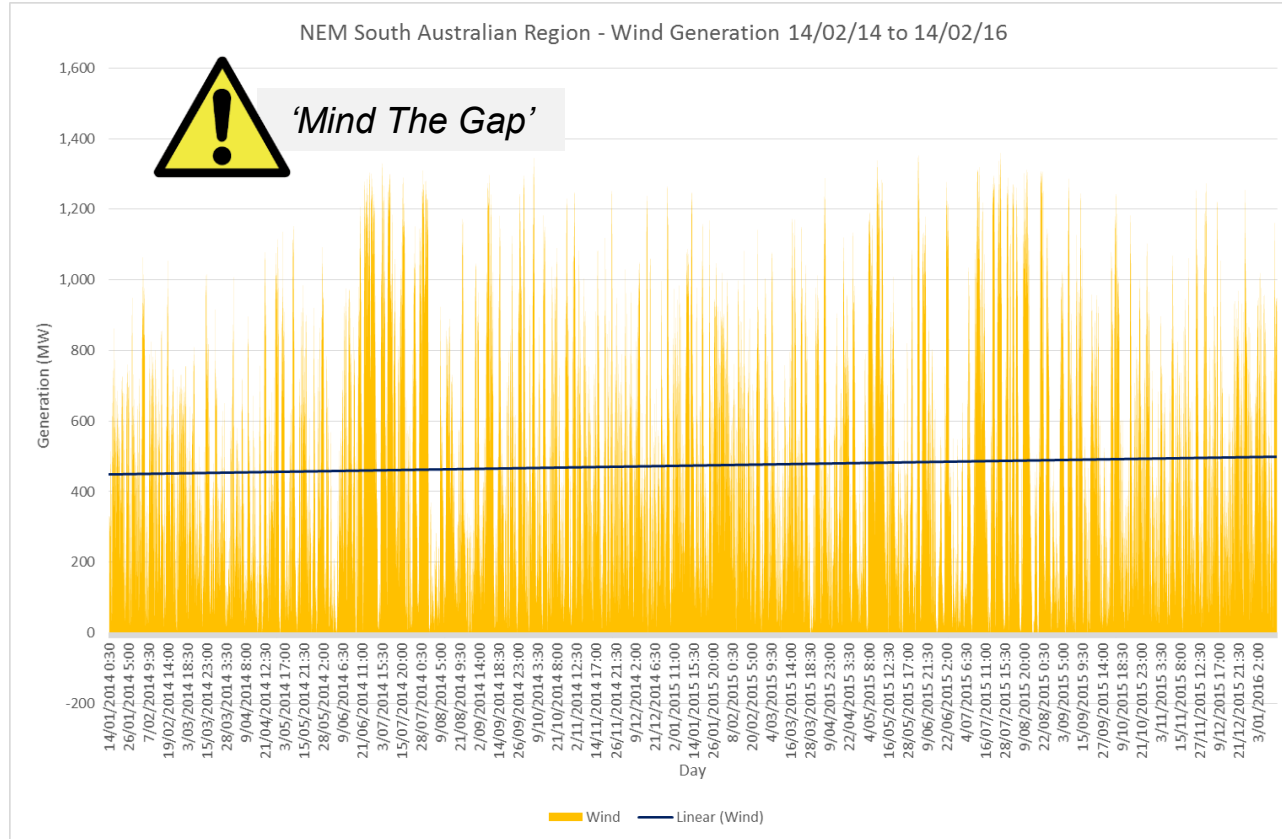

NEM South Australian Region – A Live Case Study

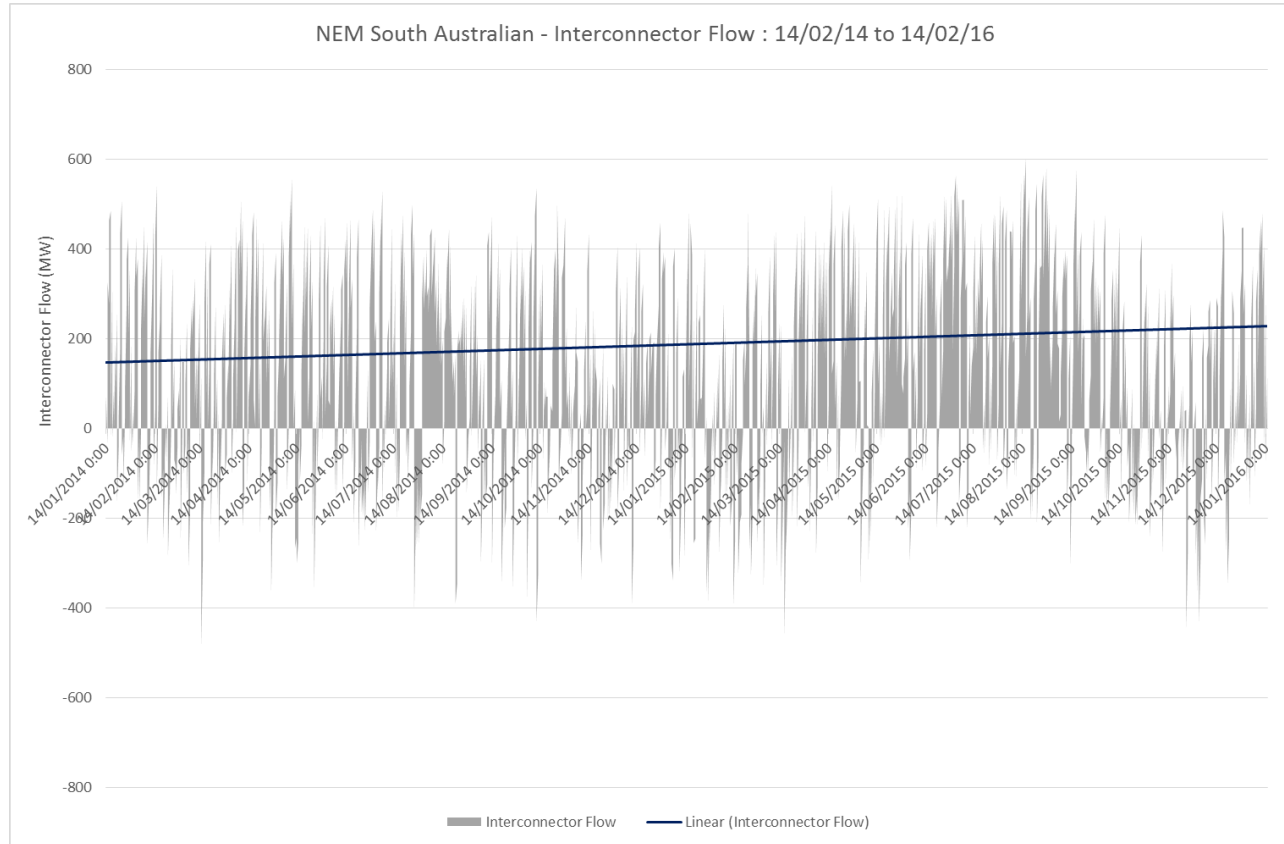

NEM South Australian Region – A Live Case Study

“A Tale of Two Days !”

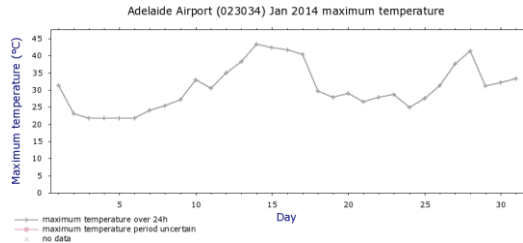
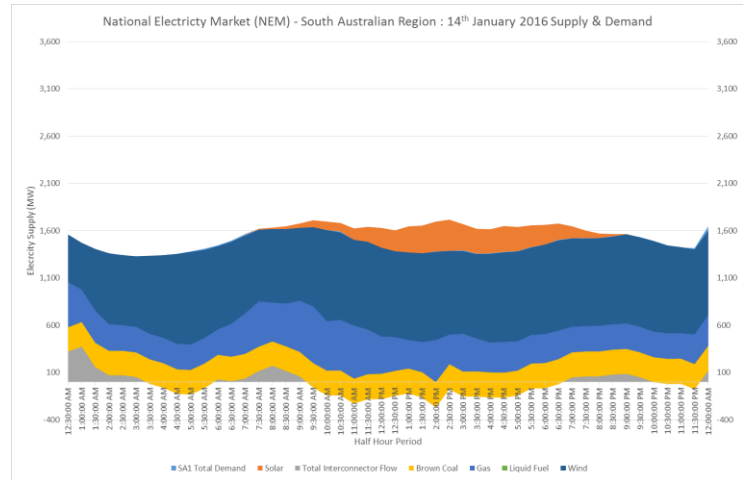
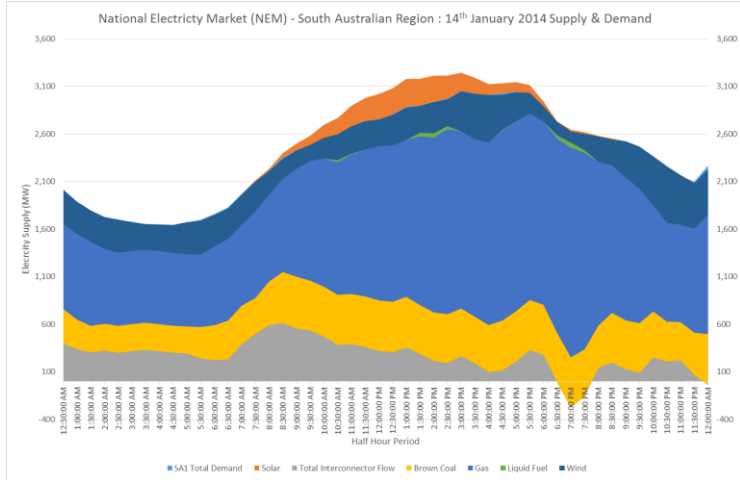

Maximum Daily Temperature
= 43.3 °C
(Adelaide Airport)

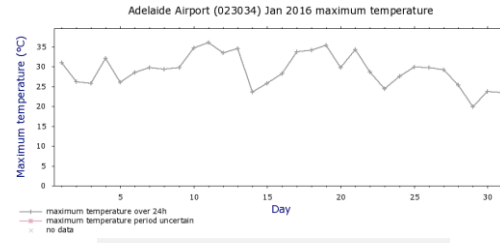

Maximum Daily Temperature
= 23.6 °C
(Adelaide Airport)



NEM South Australian Region – A Live Case Study

Top of stack = Victorian NEM Region Demand

Victorian NEM Region Generation

Victorian NEM Region Demand

Victorian NEM Region Export

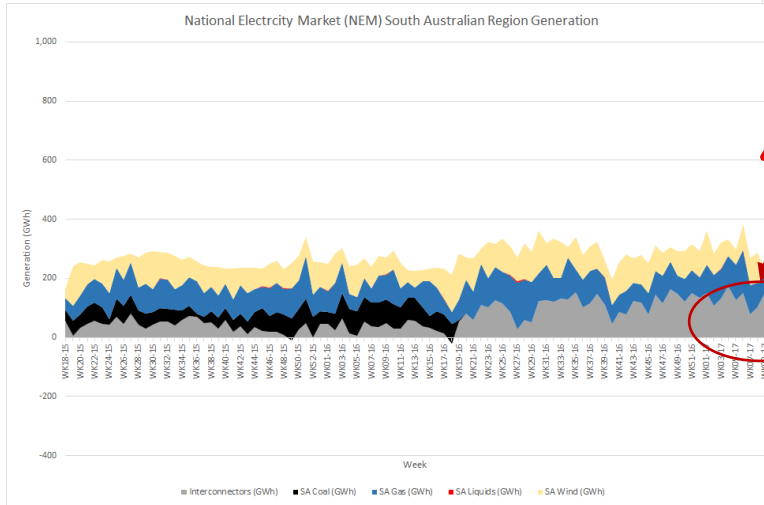
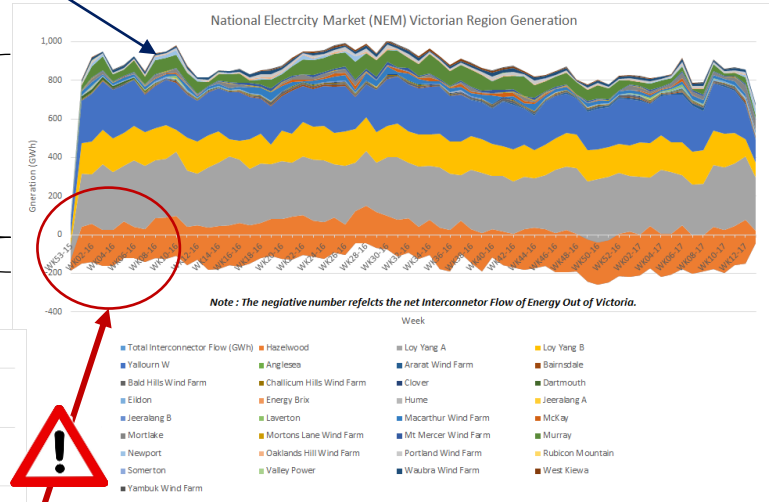

With the closure of Hazelwood Power Station in Victorian at the end of March 2017, the National Electricity Market (NEM) Victorian Region will struggle to be a net exporter of Electricity.

South Australian NEM Region Imports

The National Electricity Market (NEM) South Australian Region is dependent on net in flows of Electricity from the Victorian Region.



Levelised Cost Of Electricity (LCOE)

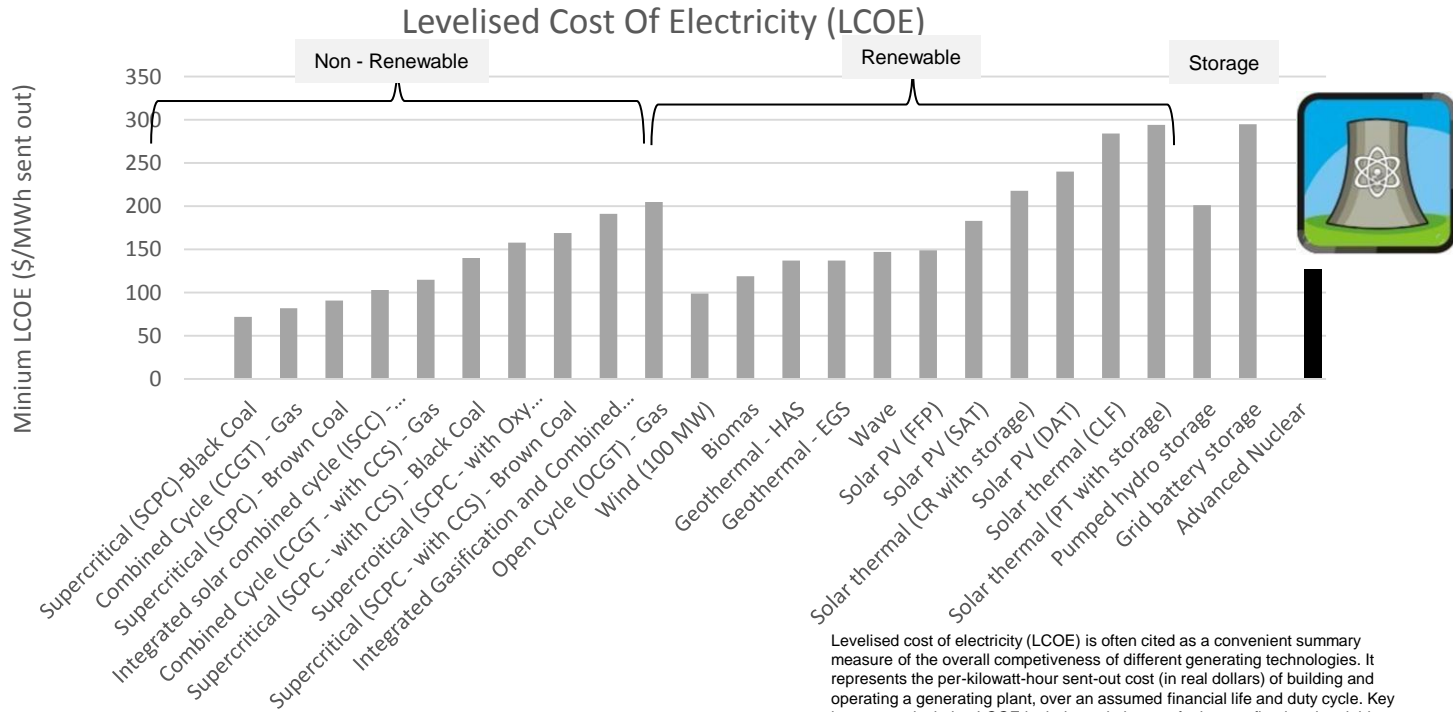

Levelised cost of electricity (LCOE) is often cited as a convenient summary measure of the overall competitiveness of different generating technologies. It represents the per-kilowatt-hour sent-out cost (in real dollars) of building and operating a generating plant, over an assumed financial life and duty cycle. Key inputs to calculating LCOE include capital costs, fuel costs, fixed and variable operations and maintenance costs, financing costs, auxiliary load and an assumed utilisation rate for each plant type.

■ Minimum LCOE (\$/MWh sent out #1)

Technology

■ Minimum LCOE (\$/MWh sent out #2)

Source #1 : AEMO, 2015, 'South Australian Fuel And Technology Report', South Australians Advisory Functions, AEMO, Melbourne, pp. 46 – 48.

Source #2 : US Energy Information Administration (EIA), 2015, 'Annual Energy Outlook 2015', DOE/ETA – 0383(2015), US Department Of Energy, Washington.
Note : Shown in A\$ based upon 1A\$ = US\$0.75



Levelised Cost Of Electricity (LCOE)

Figure 14 South Australia LCOE versus capacity factor

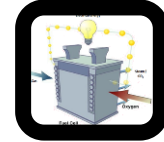
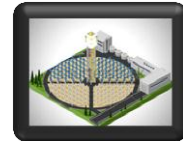
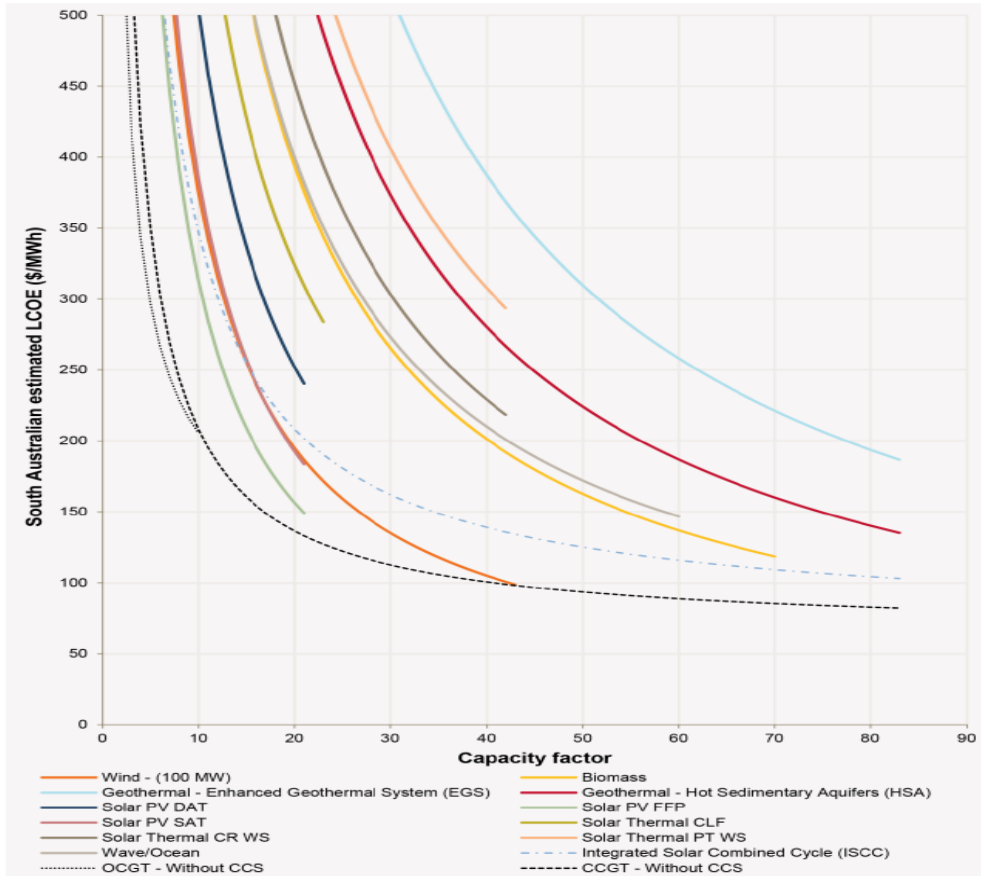

Solar PV

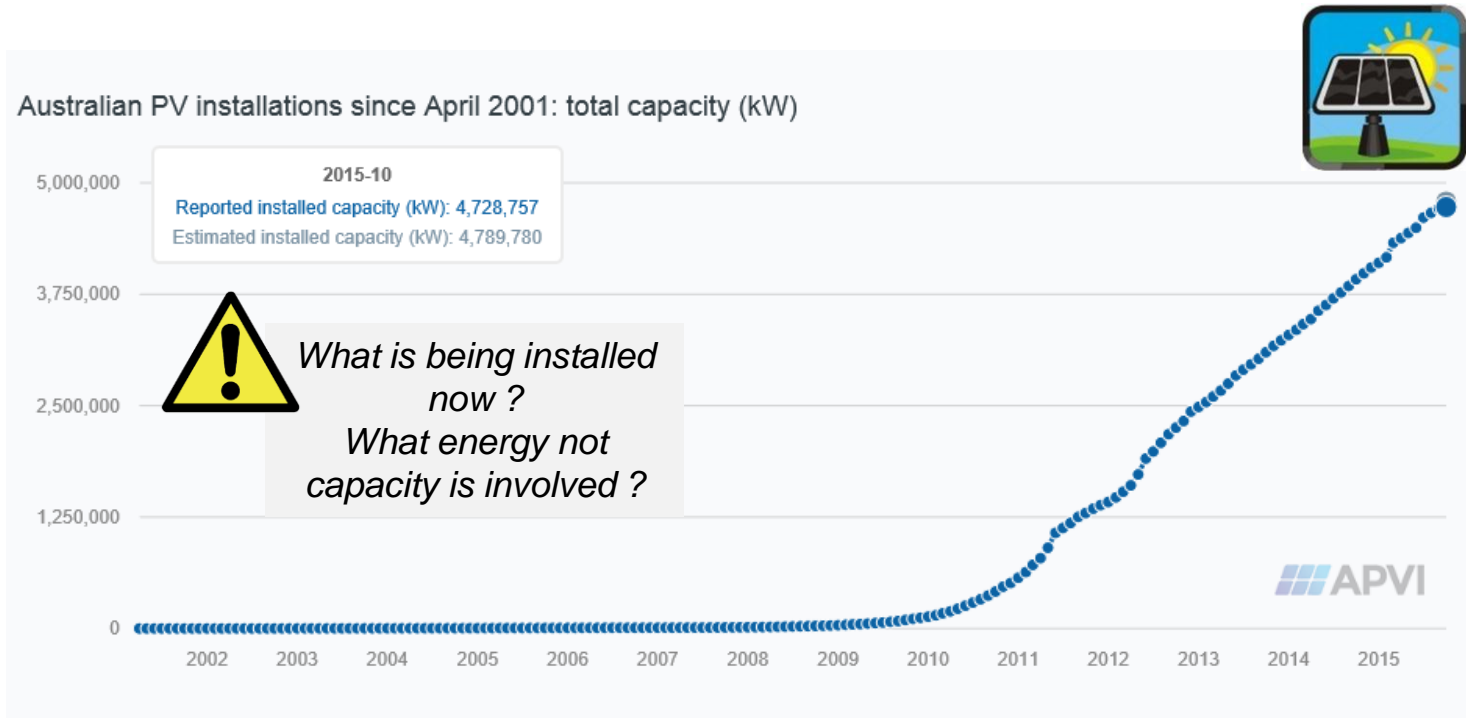

Solar PV

Compare PV installation sizes across postcodes

Explore per-postcode domestic and commercial PV across different installation sizes. Scroll and select from the postcodes on the right to add them to the data set. Select the system size categories to toggle their visibility.



Solar PV In The NEM South Australian Region

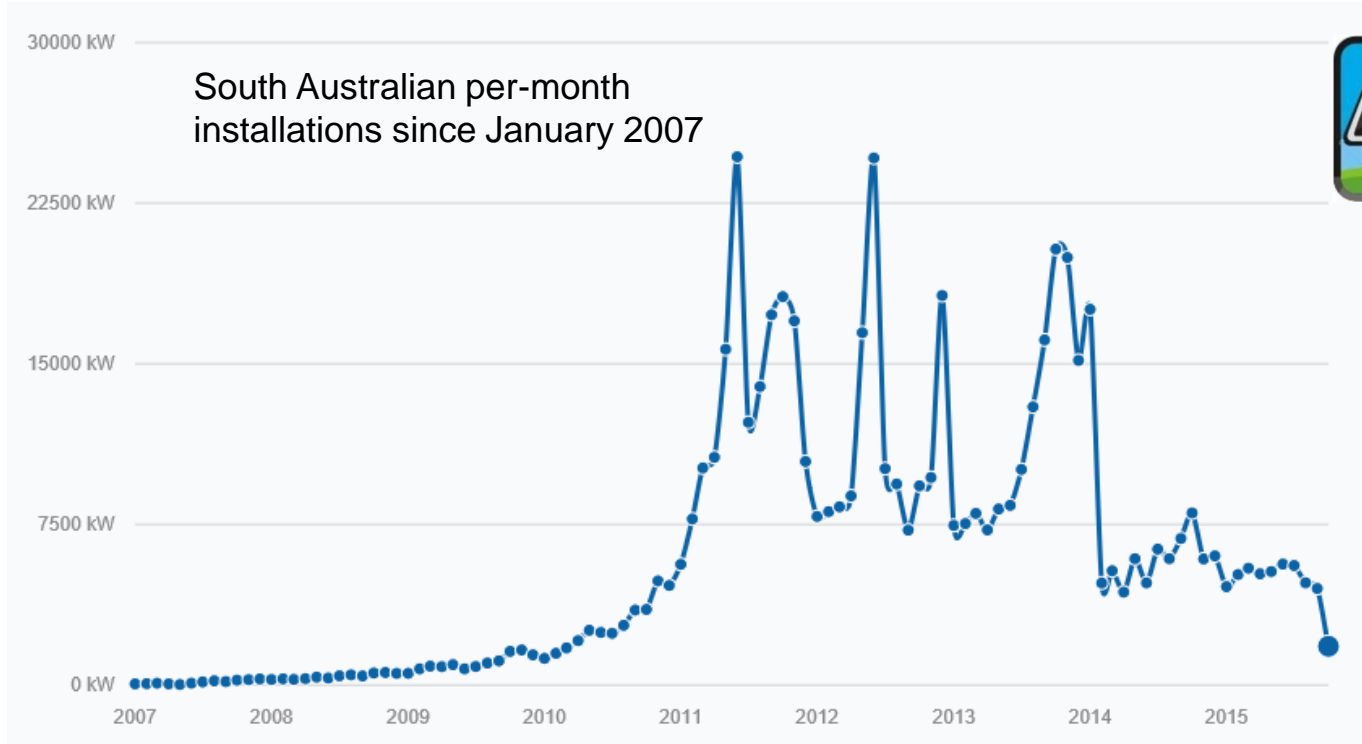

Solar PV In The NEM South Australian Region



High Day Solar PV Generation Day in South Australia, 14th March 2015

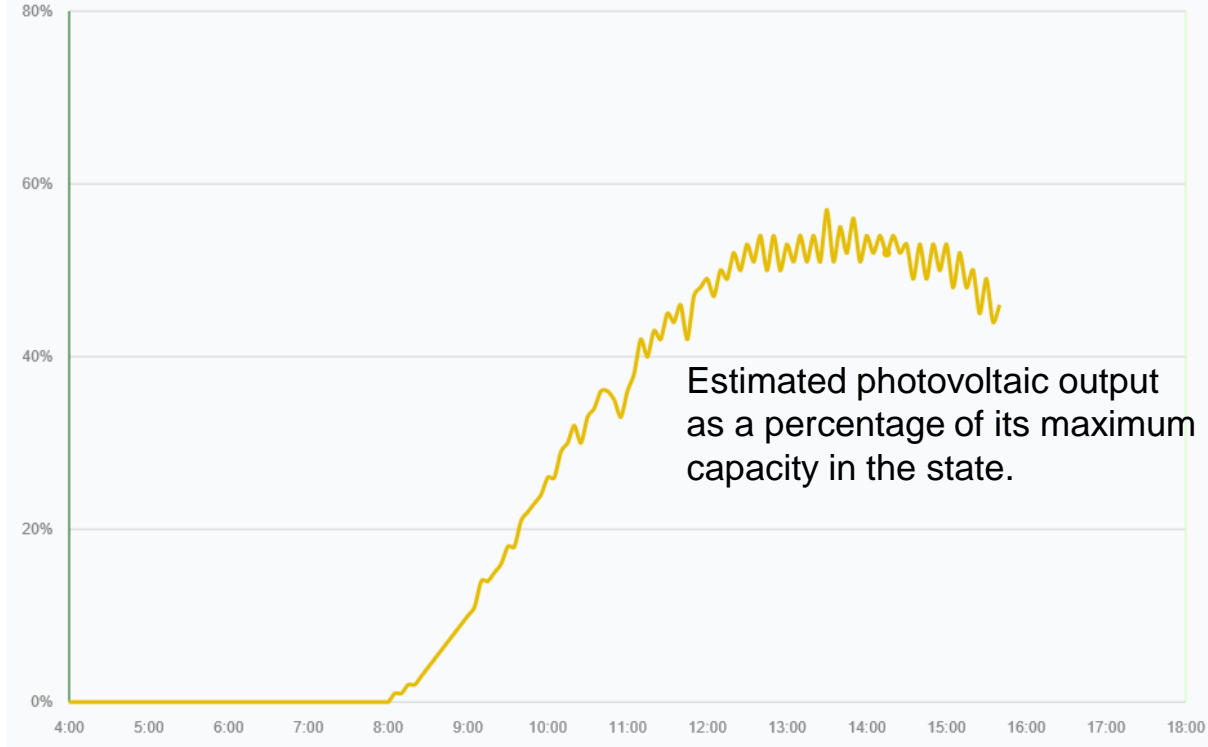

Solar PV In The NEM South Australian Region

Elizabeth North: 11/2/2016 – 18/2/2016 ▾

PV system size 8.32 kWp

Orientation 345°NNW

Tilt 20°

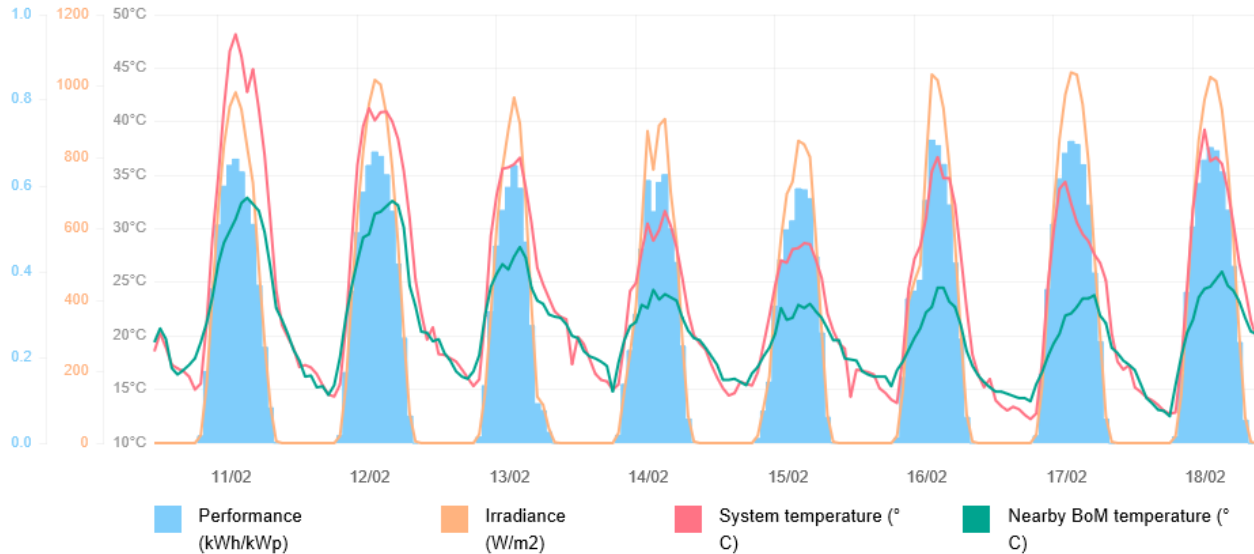

Energy Storage Technology

Summary of Energy Storage technologies (ES)

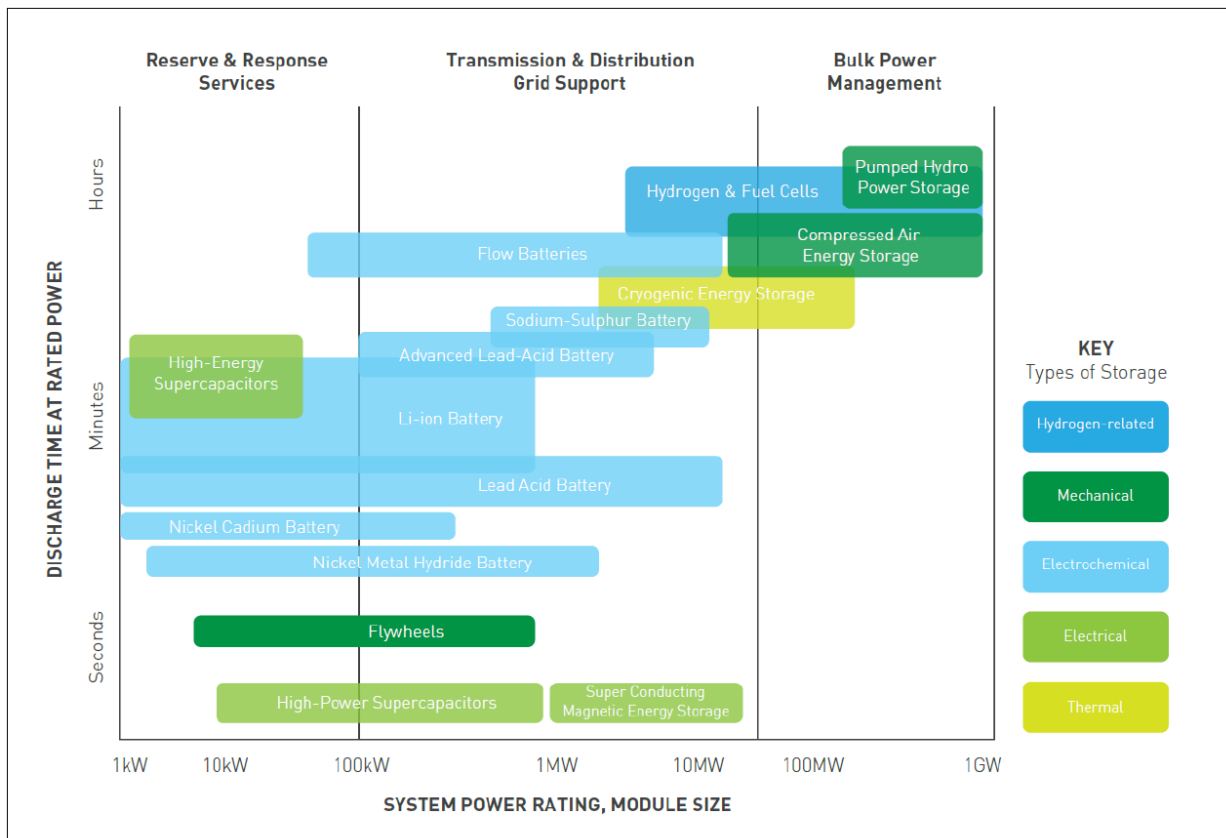

Source : CSIRO.



What Must The Grid^{#1} Seek To Address ?

Note : #1 – In this context the term “The Grid” not only is taken to mean the Transmission and Distribution Networks but, also the inputs to The Grid (Generation) and elements that can facilitate and stabilise The Grid (Storage, Ancillary Services).

- **Reliable,**
- **Cost Effective,**
- **Safe,**
- **Sustainable,**
- **Facilitate Low Carbon / No Carbon solutions,**
- **Accommodate differing Generation technologies,**
- **Accommodate varying scales of supply,**
- **Support Grid stability,**
- **Be much more responsive the changes in Demand and Supply,**



A New Approach



“The Transformative
Power Plant”

The Transformative Power Plant – A New Approach

So, in understanding the nature of the challenges we face, the imperative has been not to focus on single technologies but rather on a process of developing solutions that make use existing and new technologies in different combinations and arrangements to meet specific needs.



The Transformative Power Plant

The 'philosophy'

Develop and demonstrate a flexible:

- **A modular,**
- **Rapidly deployable,**
- **High efficiency,**
- **Low emission grid scale,**
- **Integrated electricity generation and storage technology,**
- **To provide secure and cost effective option to allow integration of Renewable Generation.**

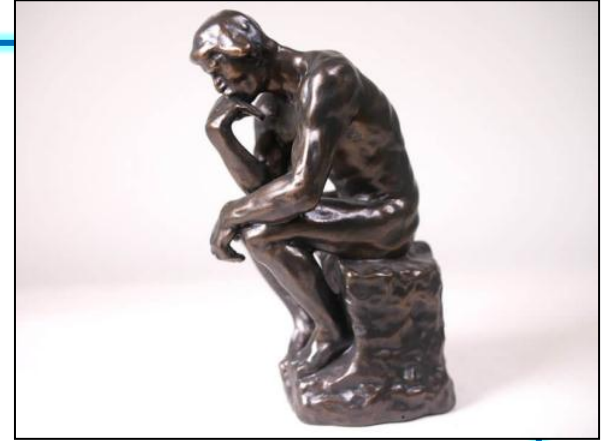

The Transformative Power Plant – A New Approach

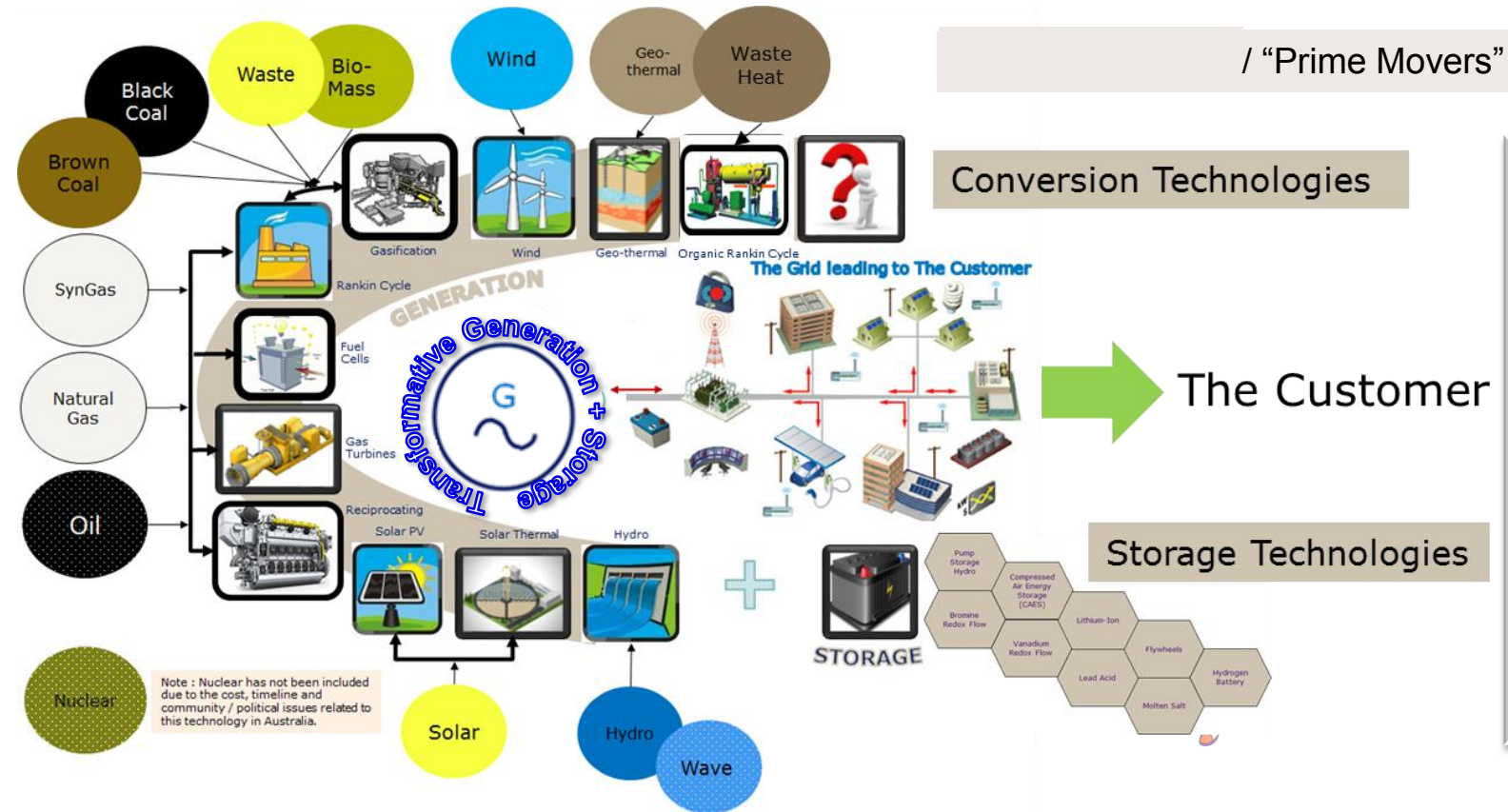

The Transformative Power Plant is based upon consideration of what issues are we seeking to resolve, consideration of what the available Primary Energy Sources / "Prime Movers" are and how can we best utilize them to solve the specific issues.

The Transformative Power Plant



The Transformative Power Plant
IS NOT A Repeat Of
FutureGen (Original Project nor 2.0) Nor
ZeroGen !

The Transformative Power Plant

Why are the ***The Transformative Power Plant*** Concepts NOT a rehash of either FutureGen (Original Project nor 2.0) nor ZeroGen ?

1. *The Transformative Power Plant* sets out to develop commercial solutions to existing and future Energy problems,
2. *The Transformative Power Plant* Concepts are NOT RESEARCH projects,
3. *The Transformative Power Plant* approach does not seek to “eat the whole elephant” of Energy Production and Carbon Sequestration in one Concept,
4. Some elements within *The Transformative Power Plant* are zero emission by their nature, for example PEM Fuel Cells operating on Hydrogen and when linked with renewable Generation as Firming the whole “Energy Chain” can be zero emission,
5. *The Transformative Power Plant* Concepts that are based upon Fossil Fuels such as Coal and Natural Gas and incorporating Fuel Cells as opposed to Gas Turbines (as in FutureGen and ZeroGen) results in lower emissions than existing technologies and by their nature provides CO₂ capture at no additional cost or equipment; High Efficiency – Low Emissions is the aim,
6. *The Transformative Power Plant* does not just seek to resolve issue around the Generation of Electricity but takes a “Polygeneration” approach to Energy Production, Energy Storage and by-products,
7. *The Transformative Power Plant* is a flexible array of elements that can be tailored to meet the problems to be solved; it IS NOT a case of “one size fits all” !

“The Transformative Power Plant”

Thinking About Storage

Energy Storage Technology

Summary of Energy Storage technologies (ES)

A key area of focus of *The Transformative Power Plant*

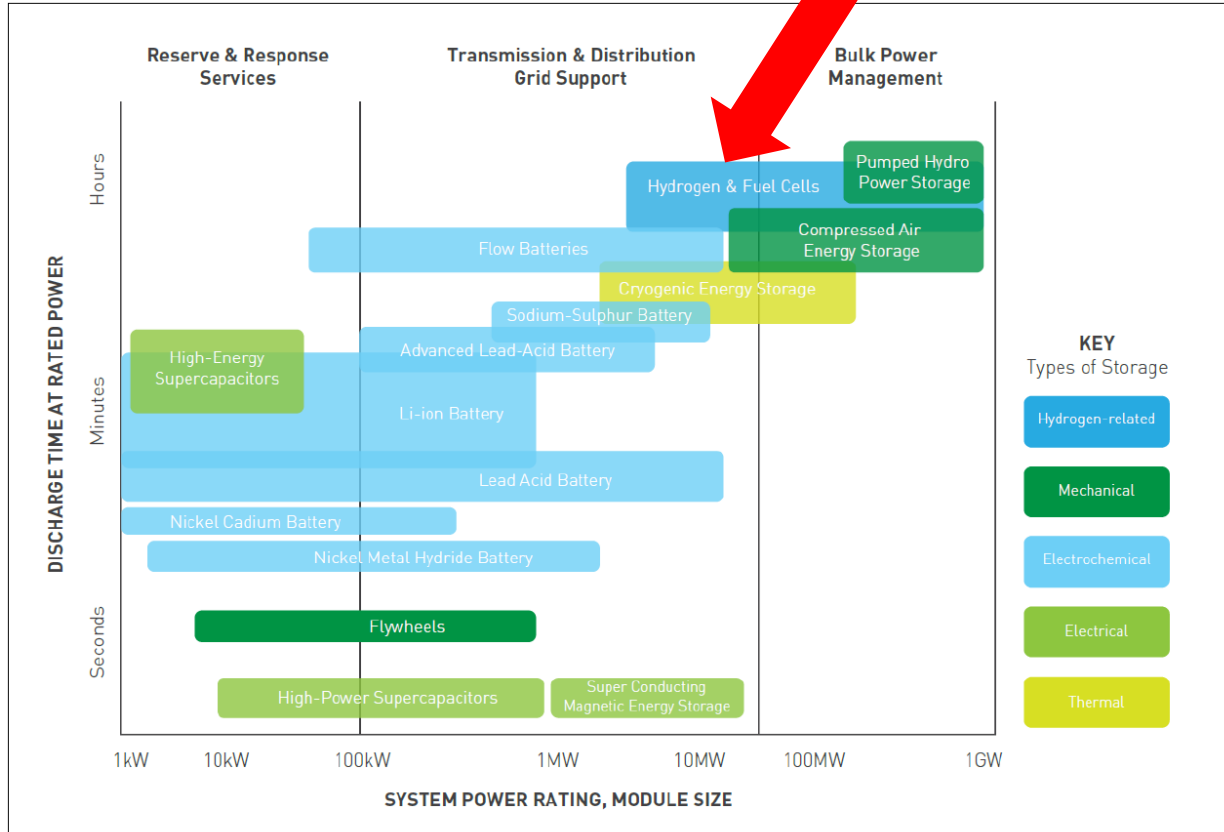

All Technologies Have Their Challenges

There Are Trade-offs Among the Five Principal Lithium-Ion Battery Technologies

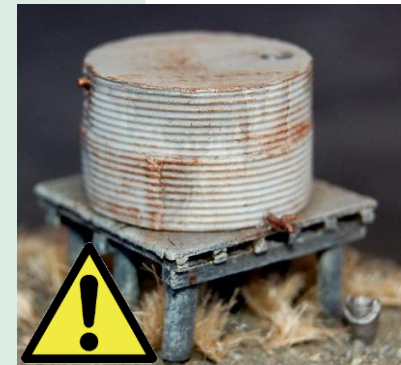
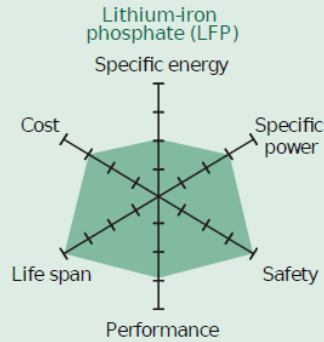
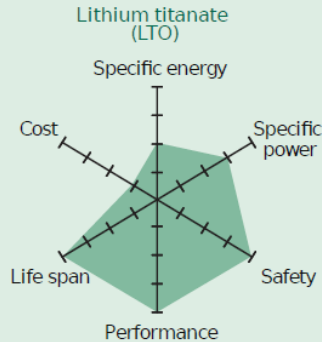
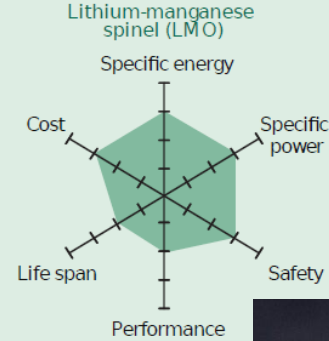
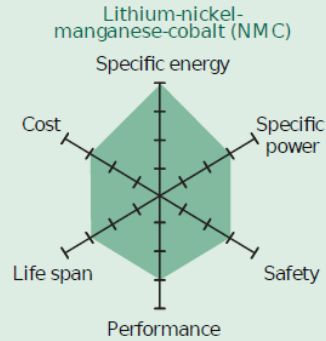
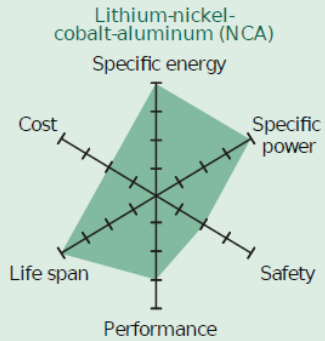

Source: BCG research.

Note: The farther the colored shape extends along a given axis, the better the performance along that dimension.



All Technologies Have Their Challenges

Who is using what

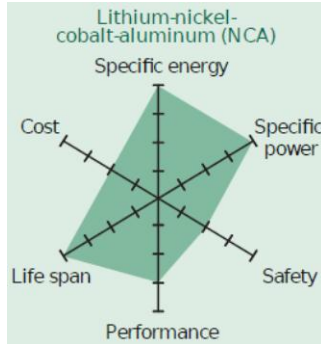

- Tesla Model S Electric Car are using Panasonic Lithium-Ion Battery with a Cathode that is a combination of a Lithium, Nickel, Cobalt, Aluminum oxide - NCA Lithium-Ion Battery.

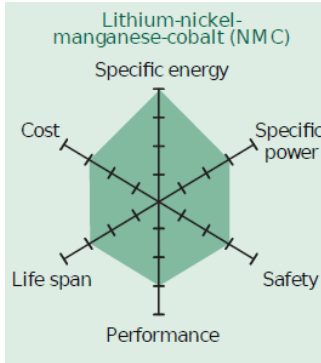
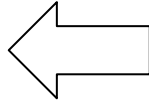

- Sunverge currently use Kokam Manganese, Cobalt - NMC based Batterys and will be moving to LGChem NMC.
- Tesla using Samsung SDI NMC Batteries in the Powerwall 1.
- Tesla moving to Tesla / Panasonic NMC in the Powerwall 2.

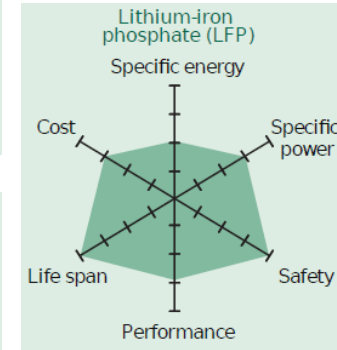
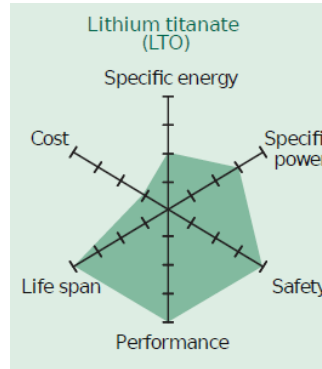
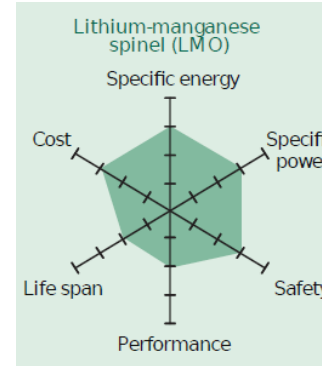
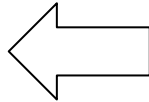

All Technologies Have Their Challenges



Ethiopian Airlines Boeing 787 “Queen of Sheba” Fire Incident at London-Heathrow Airport, UK, 2013.



- ELT mounting points
- Composite intercostal
- Coaxial cable
- ELT



Kahuku Wind Farm, Hawaii, USA – energy storage system fire, 2012



Hoverboard exploded in flames while being ridden.

“The Transformative Power Plant”

Applying The Approach
– Plant Concepts

The Transformative Power Plant

Applying The Approach – Plant Concepts

To illustrate the application of **The Transformative Power Plant** approach, a number of possible applications have been formed up in the following Concepts.

- Concept 1 - Brown Coal Gasification, Generation, Storage + Hydrogen Economy,
- Concept 2 - *SMARTGEN21*, Natural Gas Based Generation + Storage,
- Concept 3 - Improving Efficiency Of Existing Thermal Plants,
- Concept 4 - Generating Electricity And Utilizing Hydrogen + Firming Renewables,
- Concept 5 - Black Coal Gasification, Generation, Storage + Hydrogen Economy,
- Concept 6 - Firming South Australian Renewables + Hydrogen Economy,
- Concept 7 - Supporting Large Scale Customers,
- Concept 8 - Supporting Natural Gas Storage Efficiency,
- Concept 9 - Synthetic Natural Gas and The Hydrogen Economy,
- Concept 10 = Adaptive Power Plant Supporting A Large On Site Mining Customer + Hydrogen Economy.

“The Transformative Power Plant” Technology Concept 1

Brown Coal Gasification +
Hydrogen Economy

Technology Concept 1 – Brown Coal Gasification + Hydrogen

TheNational

Hydrogen is the energy of the future for Japan

By : Richard Smith, Foreign Correspondent
May 16, 2016 Updated: May 16, 2016 01:54 PM

TOKYO : To become reality, Tokyo's dream to have approaching 1 million hydrogen fuel-cell vehicles on Japan's streets in 15 years time will require huge investment and major government support, analysts say.

A March report by Japan's ministry of economy, trade and industry projects putting 40,000 hydrogen fuel-cell cars on the country's roads by 2020, with a 20-fold expansion to 800,000 by 2030. Currently, about 400 such vehicles operate in Japan, the report says.

The report also outlines plans to double the number of hydrogen fuelling stations to about 160 by the end of the current fiscal year next March, doubling it again to 320 over the following five years.

Prime Minister Shinzo Abe has called hydrogen "the energy of the future," one that would allow Japan to diversify energy sources and cut carbon dioxide emissions.

...



Technology Concept 1 – Brown Coal Gasification + Hydrogen

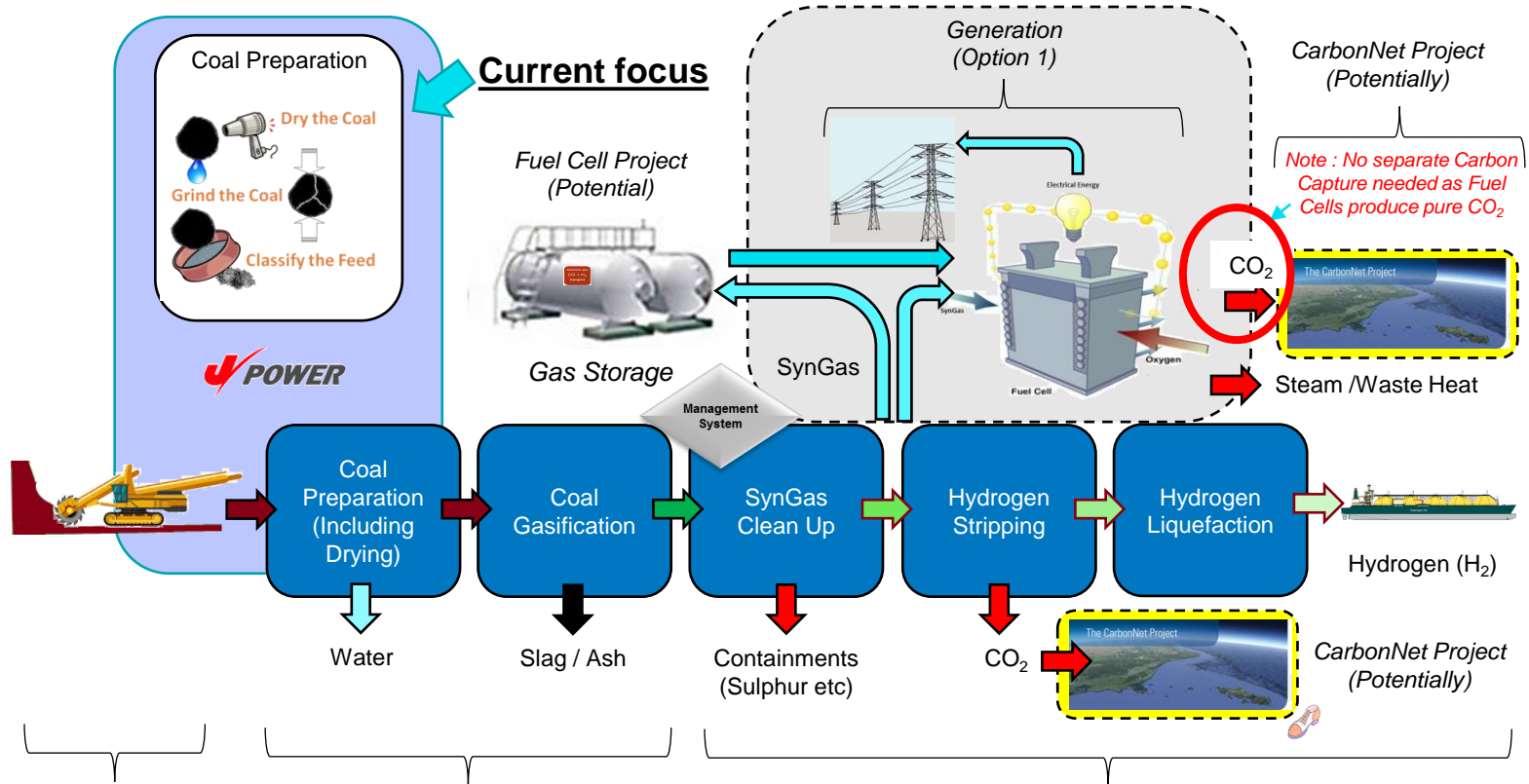

Technology Concept 1 – Brown Coal Gasification + Hydrogen

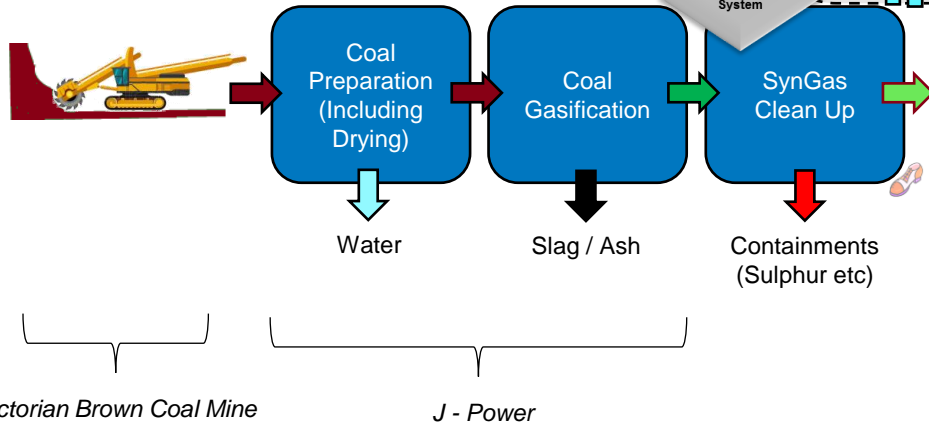
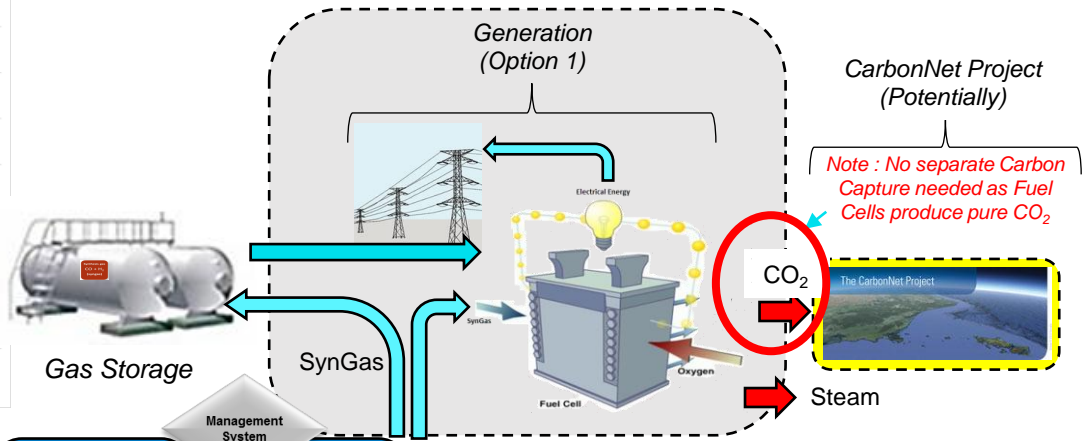
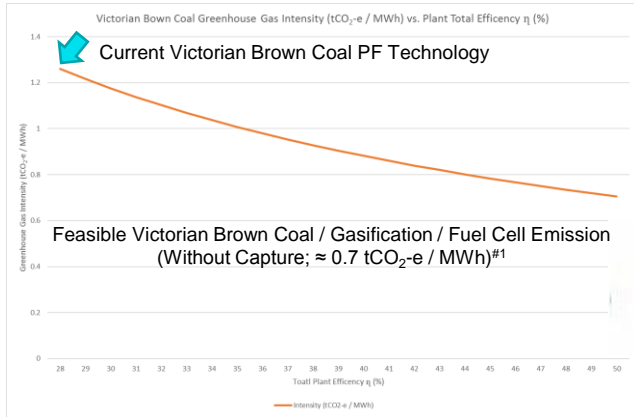

Note : #1 – Assumes that Auxiliary Power (House / Parasitic Load) remains constant between technologies and thus will err on the side of caution.

Fuel Cells (either Direct Molten Carbonate Direct Fuel Cells (DMCFC) using SynGas and / or Polymer Electrolyte Membrane (PEM sometimes referred to as Proton Exchange Membrane) Fuel Cells (PEMFC) utilising Hydrogen). MDCFCs are commercially available in blocks up to approximately 3.9 MW per block and PEMFCs are being trialled in a 2 MW block currently.

Technology Concept 1 – Brown Coal Gasification + Hydrogen

Fuel Cells (either Direct Molten Carbonate Fuel Cells (DMCFC) using SynGas and / or Polymer Electrolyte Membrane (PEM sometimes referred to as Proton Exchange Membrane) Fuel Cells (PEMFC) utilising Hydrogen). DMCFCs are commercially available in blocks up to approximately 3.9 MW per block and PEMFCs are being trialled in a 2 MW block currently.

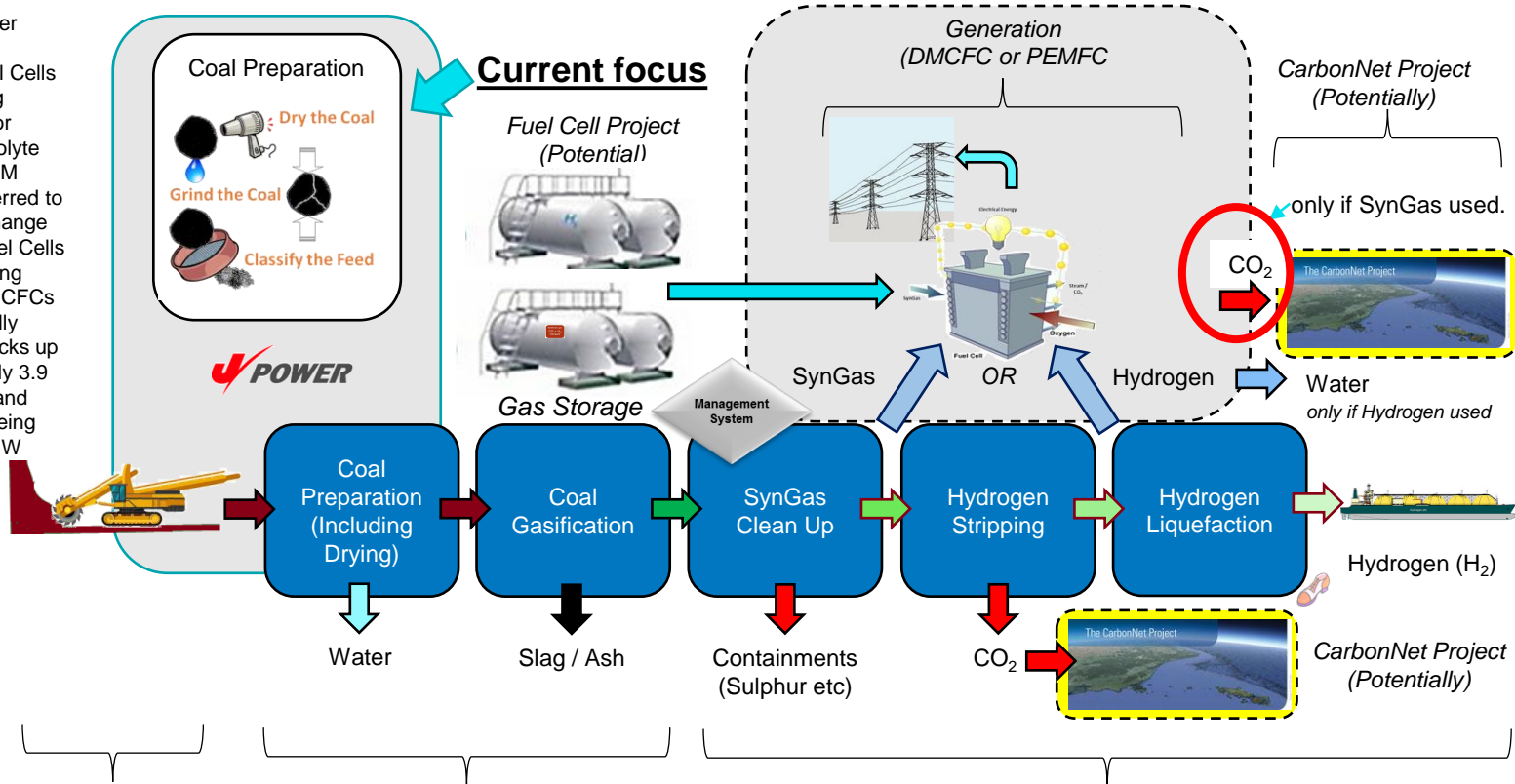

Technology Concept 1 – Brown Coal Gasification + Hydrogen

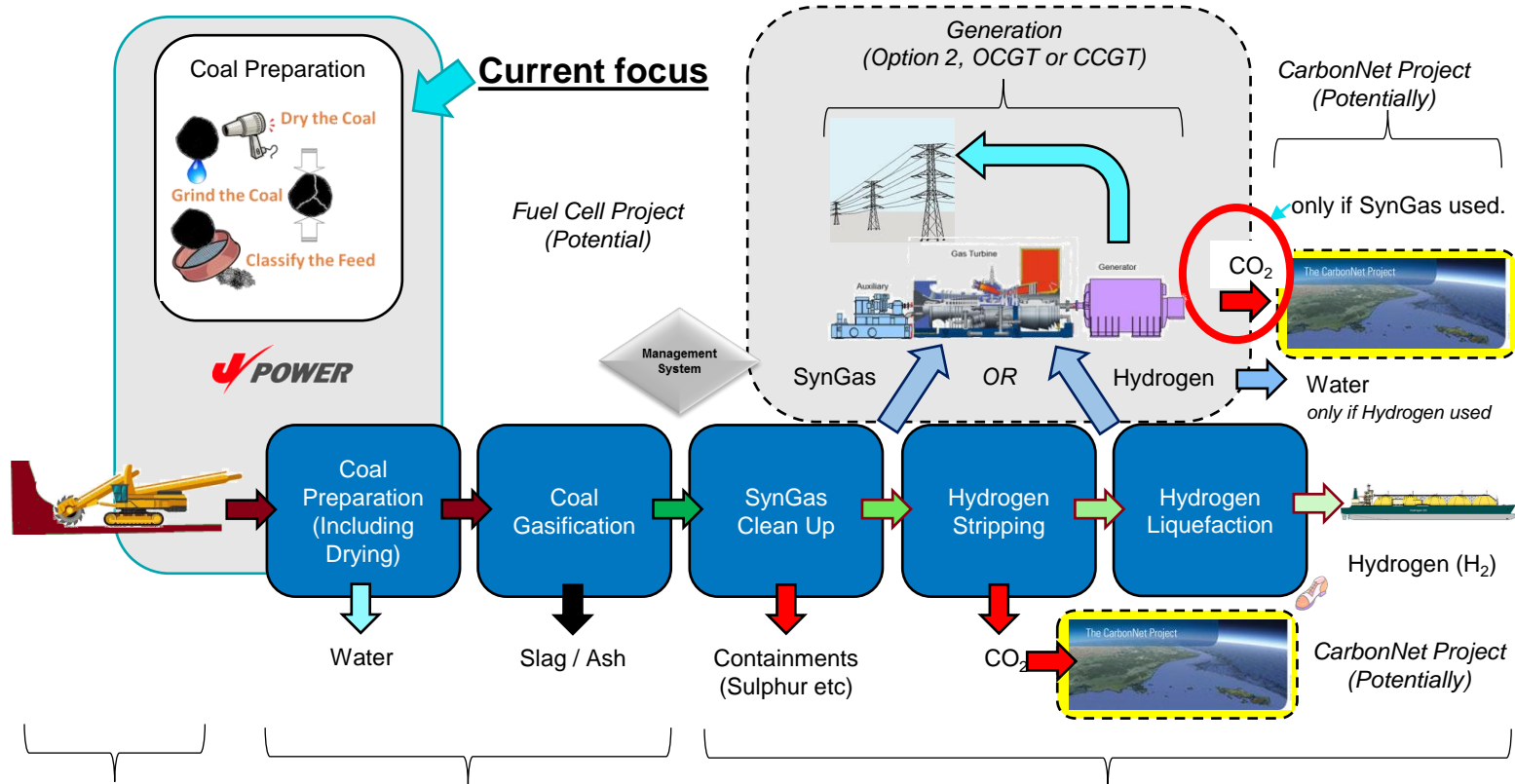

Technology Concept 1 – Brown Coal Gasification + Hydrogen

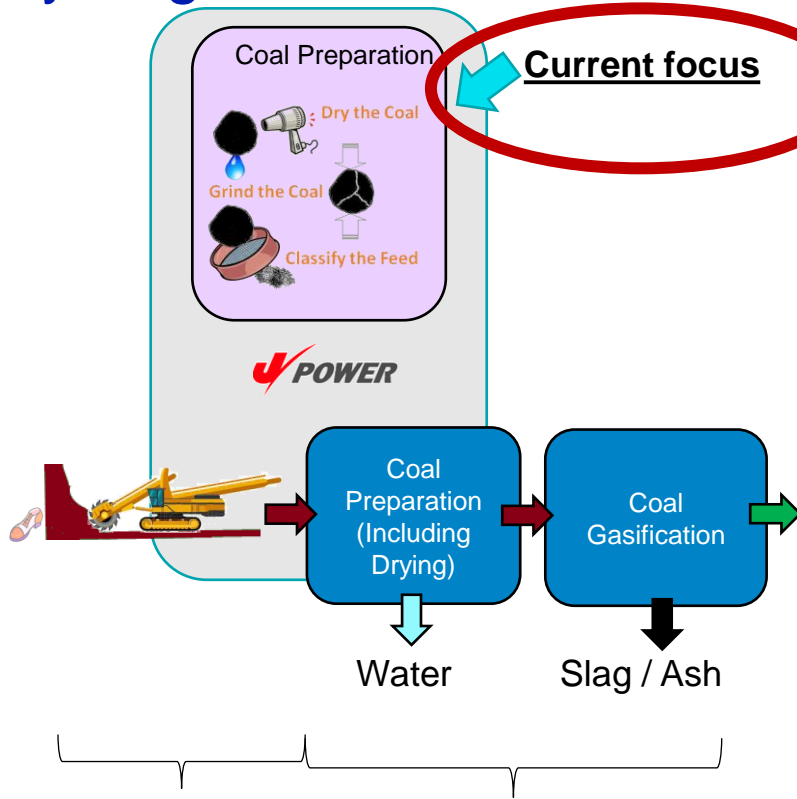

Current challenge is reduction of the moisture in Victorian Brown Coal to allow the use of commercial available and proven Gasifier technology in the most efficient manner.

High Efficiency Fuel Cell Concept

Fuel Cells (either Direct Molten Carbonate Direct Fuel Cells (DMCFC) using SynGas or Natural Gas and / or Polymer Electrolyte Membrane (PEM sometimes refer to as Proton Exchange Membrane) Fuel Cells (PEMFC) utilising Hydrogen). MCDFCs are commercially available in blocks up to approximately 3.9 MW per block and PEMFCs are being trialled in a 2 MW block currently.

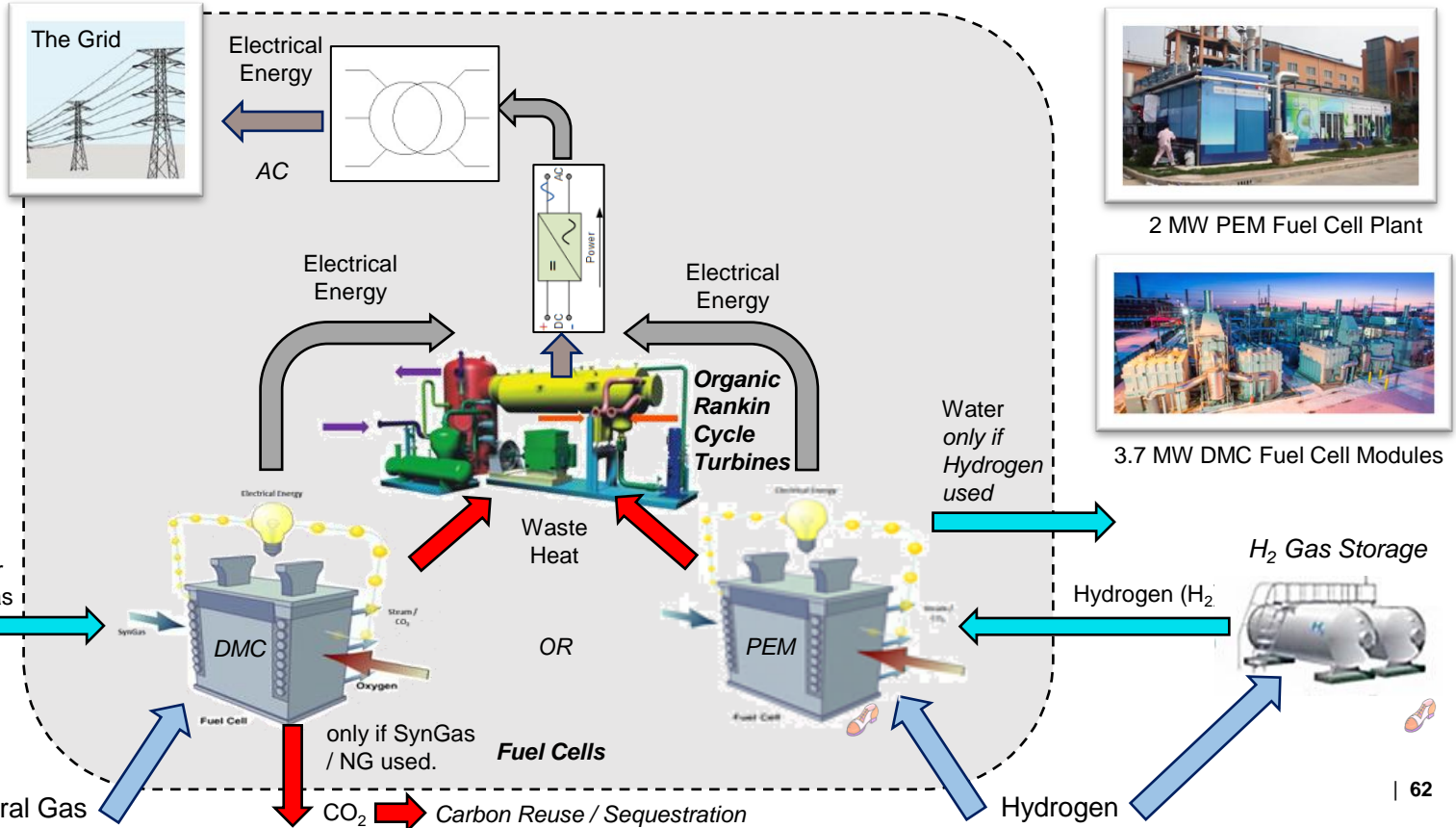

High Efficiency Fuel Cell Concept + Solid Sequestration

DMC Fuel Cells produce low quantities of pure CO₂ which opens the way for Solid Sequestration

Fuel Cells (either Direct Molten Carbonate Direct Fuel Cells (DMCFC) using SynGas or Natural Gas and / or Polymer Electrolyte Membrane (PEM sometimes referred to as Proton Exchange Membrane) Fuel Cells (PEMFC) utilising Hydrogen). MCDFCs are commercially available in blocks up to approximately 3.9 MW per block and PEMFCs are being trialled in a 2 MW block currently.

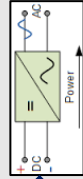
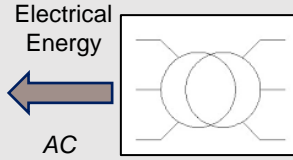
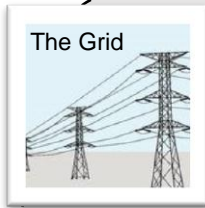

Electrical Energy

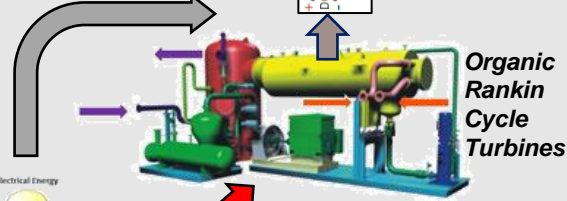

Waste Heat

OR

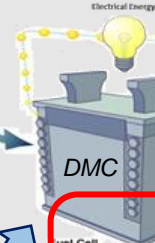

only if SynGas / NG used.

Fuel Cells

CO₂ → Carbon Reuse / Sequestration

SynGas Storage



SynGas or Natural Gas



Transforming CO₂ into products for building

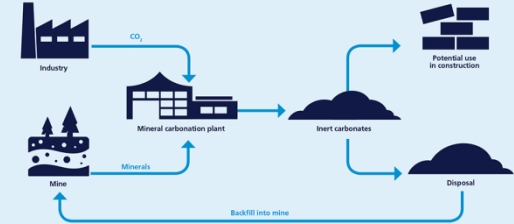

Technology Concept 1 – Brown Coal Gasification + Hydrogen

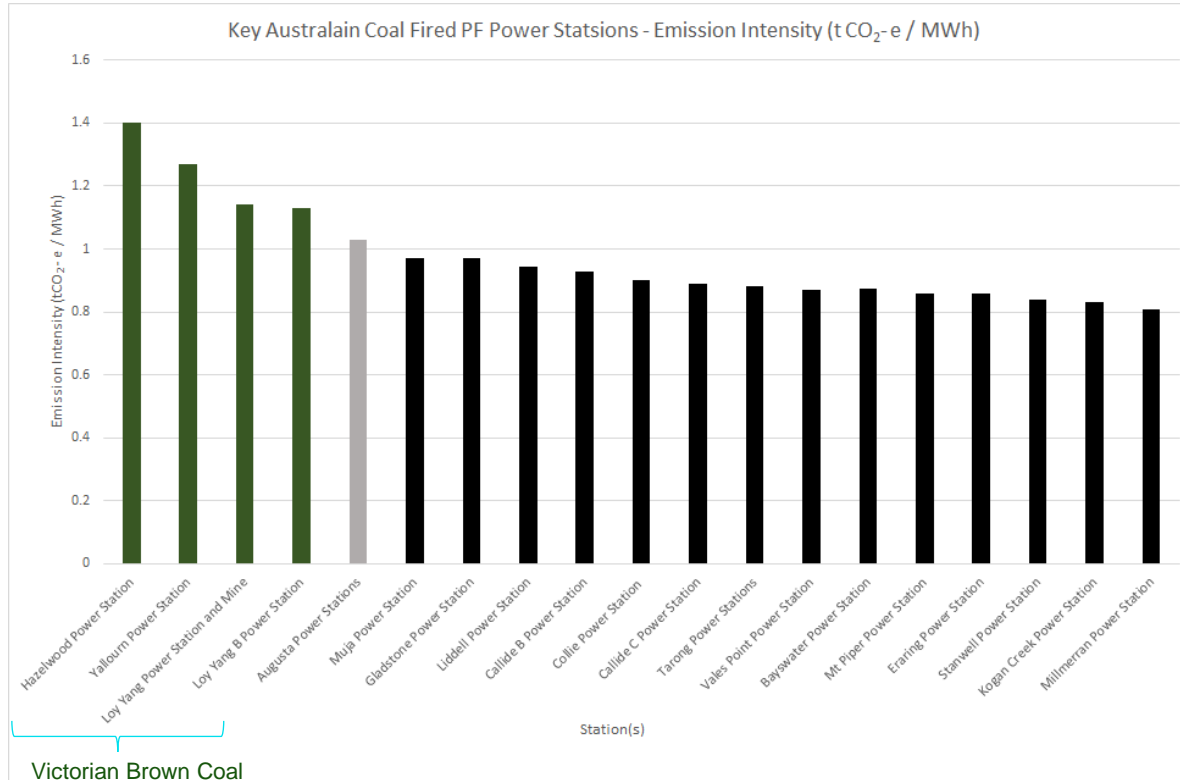

“The Transformative Power Plant” Technology Concept 2

SMARTGEN21

Electricity Generation and Storage for the 21st Century

Transformative Power
Plant – *SMARTGEN21*
South Australia

Technology Concept 2 – SMARTGEN21 Power Plant

A key solution for South Australia

Electricity Generation and Storage for the 21st Century

The Mission :

Develop and demonstrate a flexible:

- **A modular,**
- **Rapidly deployable,**
- **High efficiency,**
- **Low emission grid scale,**
- **Integrated electricity generation and storage technology,**
- **To provide secure and cost effective option to allow integration of Renewable Generation.**



Technology Concept 2 – *SMARTGEN21* Power Plant

SMARTGEN21

Electricity Generation and Storage for the 21st Century

What a Solution might look like :

- **Additional Efficient Generation needed in South Australia,**
- **A need to deploy solutions quickly,**
- **A need for Storage to maximise Renewables Intermittency,**
- **Reduce Environment Impacts,**
- **Modula and Expandable Technology,**
- **Limited support Infrastructure needed.**



Technology Concept 2 – SMARTGEN21 Power Plant

SMARTGEN21

Electricity Generation and Storage for the 21st Century

A Solution :

- **59 MW Direct Fuel Cell Generation,**
 - ✓ **Natural Gas Fueled,**
 - ✓ **60% Efficient, - Highest in Australia,**
 - ✓ **Low CO₂ Emission, - 0.25 tCO₂-e / MWh, Lowest in Australia^{#1},**
- **60 MWh Redox Flow Battery, - Safe and Environmentally Friendly,**
- **Deployment commencing in 9 months,**
- **Modular, progressive build up and sized to requirements,**
- **Combining Proven Technologies in a 21st Century Manner.**

Note : #1 – Assuming Waste Heat Recovery, CO₂ Emissions range between 0.25 and 0.308 tCO₂-e/MWh.



Technology Concept 2 – *SMARTGEN21* Power Plant

SMARTGEN21

Electricity Generation and Storage for the 21st Century

A Solution :

- **Location : Torrens Island / Pelican Point,**
 - ✓ **Natural Gas Supply,**
 - ✓ **Electrical Grid Connection,**
 - ✓ **Water Available,**
 - ✓ **Support Services,**
 - ✓ **Near Load Center of Adelaide,**
 - ✓ **Short Fall in South Australian Region with Hazelwood Closed,**
(Haywood Interconnector Flow to South Australia is likely to be reduced)
 - ✓ **Suitable Land Available,**



Technology Concept 2 – *SMARTGEN21* Power Plant

SMARTGEN21

Electricity Generation and Storage for the 21st Century

A Solution :

- Torrens Island 'A' Power Station Heat Rate : 12.5 GJ / MWh,
- Torrens Island 'B' Station Heat Rate : 11.5 GJ / MWh,
- *SMARTGEN21* Generation Heat Rate : 6.1 GJ / MWh^{#2},
- Waste Heat from the *SMARTGEN21* Fuel Cells would be available for Heat Recovery via Organic Rankine turbine that converts waste heat from the fuel cells into additional electricity.

Note : #2 – Based upon Lower Heating Value (LHV), based upon Higher Heating Value (HHV) = 4.8 GJ / MWh.



Technology Concept 2 – SMARTGEN21 Power Plant

SMARTGEN21

Electricity Generation and Storage for the 21st Century

**GENERATION
+ STORAGE**



GENERATION:
16 off *FuelCell Energy's* DFC4000 – 3.7 MW
Direct Molten Carbonate Fuel Cells



STORAGE:
Sumitomo Electric Redox Flow
Battery



Technology Concept 2 – SMARTGEN21 Power Plant

SMARTGEN21

Electricity Generation and Storage for the 21st Century

Great Improved Environmental Performance :

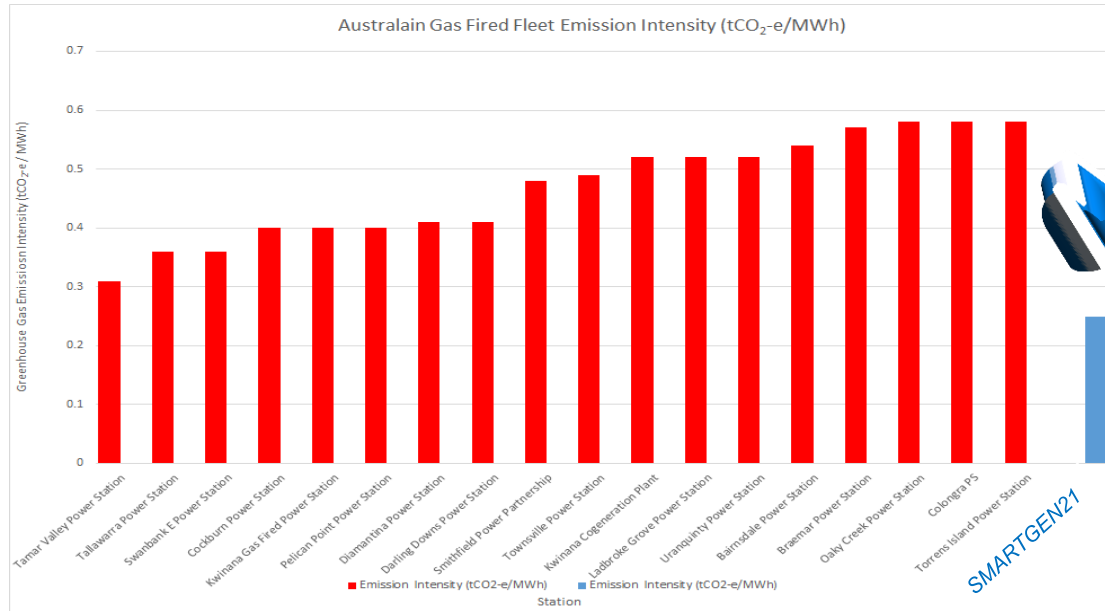

Technology Concept 2 – SMARTGEN21 Power Plant

SMARTGEN21

Electricity Generation and Storage for the 21st Century

GENERATION

Existing Technology :

Dominion Bridgeport Fuel Cell

Dominion Bridgeport Fuel Cell is located in downtown Bridgeport, CT, along Interstate 95 and the Northeast rail corridor. The facility began commercial operations on Dec. 27, 2013, and produces 14.9 megawatts of clean energy using an electro-chemical process that efficiently converts natural gas into electricity.

FuelCell Energy Inc. operates and maintains the facility under a services contract with Dominion. FCE supplied five Direct FuelCell® stationary fuel cell power plants and an organic rankine turbine that converts waste heat from the fuel cells into additional electricity.

Dominion sells the output of the fuel cell power station to Connecticut Light & Power under fixed power purchase agreements.

Dominion Bridgeport Fuel Cell is part of Project 150, a program sponsored by the state and supported by the Clean Energy Finance and Investment Authority (CEFIA) to increase renewable and clean energy projects in Connecticut by 150 megawatts. CEFIA is the nation's first full-scale clean energy finance authority that leverages public and private funds to drive investment and scale up clean energy deployment in Connecticut.



15 MW Dominion Bridgeport Fuel Cell Plant, Bridgeport, Connecticut, U.S.A., uses 0.6 of a Ha. of land and powers approximately 2% of Connecticut Renewable Portfolio Standard.

Source : Kenji Kaneko, Nikkei BP CleanTech Institute, 2016/01/05 ,



Technology Concept 2 – SMARTGEN21 Power Plant

SMARTGEN21

Electricity Generation and Storage for the 21st Century

GENERATION

Existing Technology :

POSCO 59 MW Gyeonggi Green Energy facility Hwasung City, South Korea

One current example is the Gyeonggi Green Energy facility which is a 59 MW Fuel Cell park in Hwasung City, South Korea. The facility commenced commercial operation on 19th of February, 2014. The plant consists of 21 off 2.8 MW Hydrogen Fuel Cells supplied by FuelCell Energy of Danbury, Connecticut, U.S.A.

South Korea is an energy-intensive country with a growing population, high urban population density and little available land. In the wake of a scandal involving falsified nuclear plant safety certificates, the nation aims to reduce its reliance on nuclear power to 29 per cent of its energy mix by 2035.

Due to a lack of domestic resources, imported fuels currently meet around 97 per cent of South Korea's energy demand. In 2013, the country was the world's second-largest importer of liquefied natural gas (LNG), the fourth-largest coal importer, and the fifth-largest oil importer.

In a move to clean up its energy mix, South Korea has had a "green growth" policy in place since 2008, with the goal of increasing its use of renewables to 20 per cent of the generation mix by 2027. Among its renewables-friendly policies, the nation has feed-in tariffs (FiTs), a renewable heat obligation and a renewable portfolio standard.

However, its terrain is hilly and thus not particularly well-suited for large solar or wind farms. In the past few years South Korea has shown a growing interest in fuel cell power, with a number of projects in the works.



*59 MW Gyeonggi Green Energy facility
Hwasung City, South Korea.*



Technology Concept 2 – SMARTGEN21 Power Plant

SMARTGEN21

Electricity Generation and Storage for the 21st Century

GENERATION

Existing Technology :

POSCO 59 MW Gyeonggi Green Energy facility Hwasung City, South Korea

The two-hectare (5.1 acre) facility in Gyeonggi Province, along the country's northwest coast, is owned and operated by POSCO Energy (POSCO formerly Pohang Iron and Steel Company and is a multinational steel-making company headquartered in Pohang, South Korea), the nation's largest independent power producer. Construction began in late 2012 and was completed in 2014. The fuel cells run on natural gas converted to hydrogen and also provide heat to the local district heating system.

"The scale of this installation is contributing to the power and heating needs of an urban population and generating the electricity in a highly efficient and ultra-low emission profile that supports our national renewable portfolio standard," said Tae-Ho Lee, CEO of Gyeonggi Green Energy.

POSCO and FuelCell Energy are planning another fuel cell project adjacent to a railroad depot operated by the Seoul Metropolitan Rapid Transit Corp. That 19.6 MW facility, composed of seven 2.8 MW Fuel Cells, will provide power to the depot and the local grid, in addition to district heating. Commercial operation is expected by the end of this year. The facility is the first of several Fuel Cell projects planned to comprise a total of 230 MW in the Seoul area.

As with the Gyeonggi facility, the fuel cells at the Seoul park will be manufactured by POSCO under license from FuelCell Energy as part of POSCO's drive to position itself in the Korean clean energy market.



59 MW Gyeonggi Green Energy facility Hwasung City, South Korea.



Technology Concept 2 – SMARTGEN21 Power Plant

SMARTGEN21

Electricity Generation and Storage for the 21st Century

GENERATION



FuelCell Energy modular Direct Molten Carbonate Fuel Cell Module.

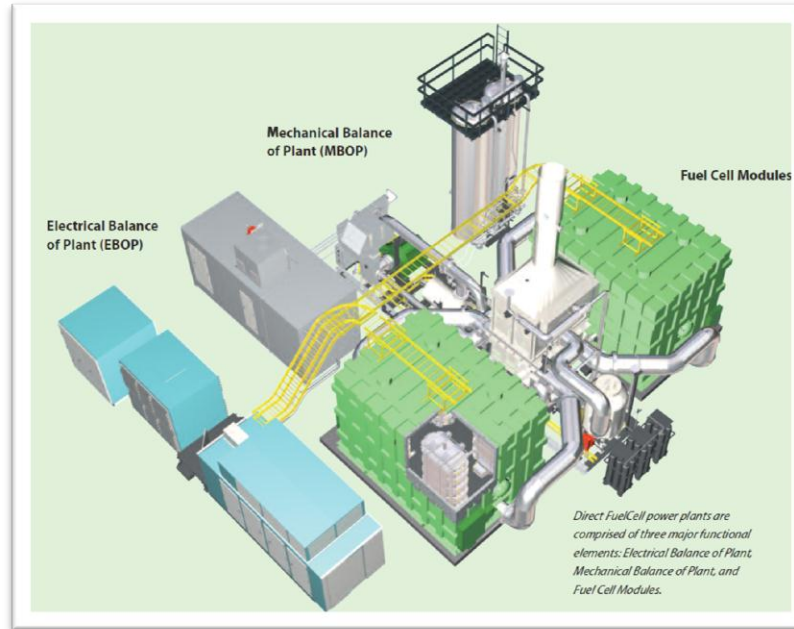

Technology Concept 2 – SMARTGEN21 Power Plant

SMARTGEN21

Electricity Generation and Storage for the 21st Century

STORAGE

Existing Technology :

60 MWh Redox Flow Battery Starts Operations to Deal With Renewable Energy

Hokkaido Electric Power Co Inc (HEPCO) and Sumitomo Electric Industries (SEI) Ltd announced Dec 25, 2015, that they have completed a large-scale storage battery system at Minamihayakita Transformer Station in Abira-chou, Hokkaido, and started to test the system. The two companies installed a redox flow battery manufactured by SEI. It has a rated output of 15MW and a capacity of 60MWh and is one of the world's largest redox flow batteries in operation.

In the verification project, which will last for about three years, HEPCO and SEI will verify the performance of the system as a new system for adjusting the output fluctuation of wind and solar power generation facilities and develop optimal control technologies.

Specifically, they will verify the following items: (1) "measure against short-period fluctuation," which charges and discharges the battery in response to rapid output fluctuations (in units of seconds) of solar and wind power generation facilities in the aim of reducing frequency fluctuation, (2) "measure against long-period fluctuation," which levels supply-demand balance by predicting the output fluctuation of solar and wind power generation facilities by the hour, (3) "measure to ensure the capacity to reduce thermal power generation" in case an output reduction at thermal power plants cannot catch up with a rapid output increase in solar/wind power generation, (4) evaluation of the redox flow battery's performance, (5) evaluation of the large-scale storage battery system's performance, (6) evaluation of the system efficiency, etc.

For the verification project, HEPCO and SEI applied for the "Emergency Verification Project for Large-scale Storage Battery System in 2012," for which Japan's Ministry of Economy, Trade and Industry (METI) called for proposals via New Energy Promotion Council (general incorporated association). And their project was selected as a subsidized project.

In Abira-chou, where Minamihayakita Transformer Station is located, SoftBank Tomatoh Abira Solar Park, which is one of the largest-scale solar power plants in Japan, started operations Dec 6, 2015. The solar panel capacity and grid capacity of the plant are about 111MW and 79MW, respectively.

Source : Kenji Kaneko, Nikkei BP CleanTech Institute, 2016/01/05 ,



An electrolyte tank in the building that stores the storage battery (source: HEPCO)



Technology Concept 2 – SMARTGEN21 Power Plant

SMARTGEN21

Electricity Generation and Storage for the 21st Century

STORAGE

Innovation :

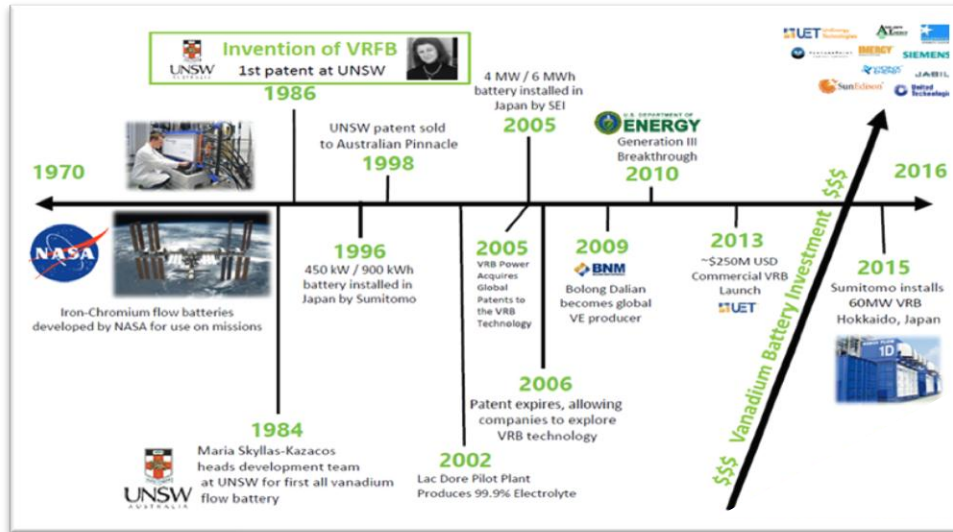

Technology Concept 2 – SMARTGEN21 Power Plant

GENERATION EFFICIENCY

Waste Heat from Fuel Cells could go to Organic Rankin Cycle Turbines to generate additional Electricity

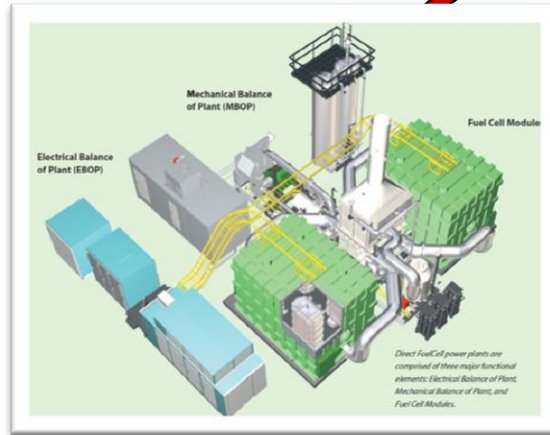

FuelCell Energy modular Direct Molten Carbonate Fuel Cell Module.

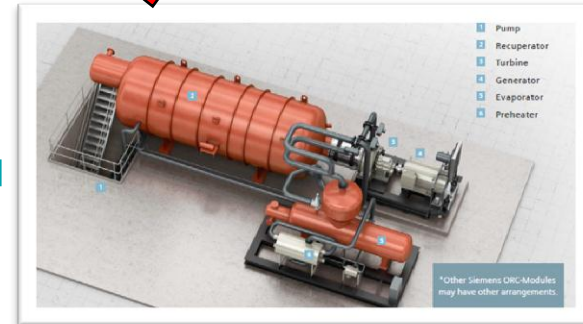

SIEMENS Organic Rankin Cycle Turbine / Generator.



The Transformative Power Plant - SMARTGEN21

SMARTGEN21

Electricity Generation and Storage for the 21st Century

GENERATION + STORAGE

May also be Solid Oxide Fuel Cell (SOFC) technology

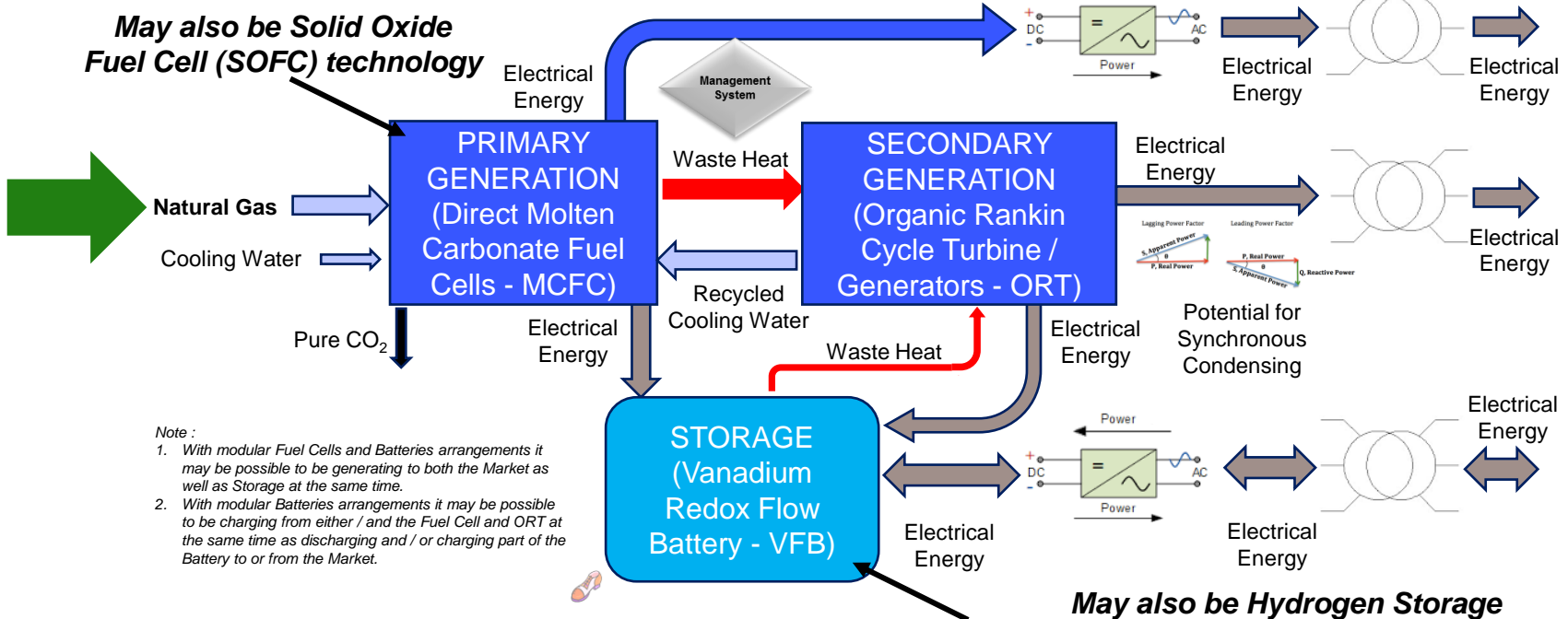

Note :

1. With modular Fuel Cells and Batteries arrangements it may be possible to be generating to both the Market as well as Storage at the same time.
2. With modular Batteries arrangements it may be possible to be charging from either / and the Fuel Cell and ORT at the same time as discharging and / or charging part of the Battery to or from the Market.

May also be Hydrogen Storage and Reuse (PEM Fuel Cells) / Sale System

Technology Concept 2 – *SMARTGEN21* Power Plant

SMARTGEN21

Electricity Generation and Storage for the 21st Century

***AUSTRALIAN
INNOVATION***

The Storage option being proposed as part of the *TRANSGEN21* concept for South Australia is based upon Vanadium Redox Flow Battery technology. *TRANSGEN21* is based upon this technology as offered by Sumitomo Electric Industries (SEI) however, the technology was original developed in Australia ! Work on the Vanadium Redox Battery (VRB) at University of New South Wales (UNSW) began in 1984. While other researchers had previously proposed the use of vanadium redox couples for redox cell applications, the UNSW breakthrough came when it was discovered that highly concentrated V(V) solutions could be prepared in sulphuric acid. The technology was taken from the initial concept stage through the development and demonstration of several 1-4 kW prototypes in stationary and electric vehicle applications over a 15 year period at UNSW. A further milestone in the UNSW R&D program, was the development of a low cost process for producing vanadium electrolyte from the vanadium oxide raw material. The original UNSW technology was used through the 1980's and 90's for a number of exciting applications.

So, the *TRANSGEN21* concept will resonate with governments who see Innovation and Australian Innovation at that as being an important element.



SMARTGEN21

Electricity Generation and Storage for the 21st Century



COST ESTIMATE- GENERATION

Fuel Cell Park Concept



Bridging The Knowledge Gap

COST ESTIMATE- GENERATION

FCE Overview

SMARTGEN21

Electricity Generation and Storage for the 21st Century



Energy Supply

\$22 billion estimated market

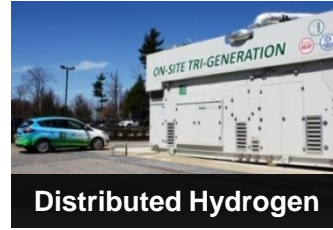

Energy Recovery

\$28+ billion estimated market

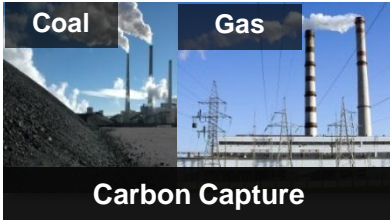

Energy Storage

Tens of \$ billions of estimated market



NASDAQ: FCEL
www.fuelcellenergy.com



Design & Manufacture



Project Development



Turn-key Project Delivery



Plant Operation

Delivering clean innovative solutions for the global supply, recovery and storage of energy

COST ESTIMATE- GENERATION

Global Relationships

SMARTGEN21

Electricity Generation and Storage for the 21st Century



N. America



Europe



Asia



Strategic Investors



Largest IPP in S. Korea
Owns 6% FCEL stock



Largest IPP in USA
Owns 3% FCEL stock

Finance Partners



Extends \$40 million
project finance facility



Manufacturing: Connecticut, USA | Germany | South Korea (via POSCO Energy)

63 MW Beacon Falls Project

- **63.3MW Base load capacity, 70MVA net(significant reactive capability)**
 - 500 GWh/yr generation
 - 15 psig (1.04 barg) fuel supply pressure
 - 7400 SCFM (12,000 nm³/hr) fuel consumption at 933BTU/SCF net calorific value (34.75 GJ/nm³)
 - 7200 MMBTU per kWh (7.6 GJ/MWh) Gross Calorific Value Heat Rate
 - (53% electrically efficient on the basis of net calorific efficiency)
 - 180 USGPM (41 m³/hr) city water usage
 - 4.3 MW of rapid load following (provided by ORC Turbine)
 - Additional 5.9 MW of fuel cell load cycling (decrease and resumption) over a four hour period
 - Transmission line voltage interconnection
 - 7 Acres (3 Hectares)
 - Emissions:
 - CO₂ – 840 lb./MWh (380 kg/MWh)
 - NO_x – <0.01 lb./MWh (<0.005 kg/MWh)
 - SO_x – <0.0001 lb./MWh (<0.00005 kg/MWh)
 - CO – <0.1 lb./MWh (<0.05 kg/MWh)
- **Scalable plant configurations are available to provide:**
 - Heat rates from 8100 to 6400 MMBTU per kWh (8.6 to 6.8 GJ/MWh) Gross Calorific Value
 - Emissions from 940 to 725 lb./MWh (430 to 330 kg/MWh)
 - Water independent operation
 - Medium voltage (distribution) or high voltage (transmission) electrical interconnection



GGE(KHNP), 60 MW Park in Korea



BFCP(Dominion), 15 MW Park in USA



Beacon Falls(proposed), 63 MW Park in USA

COST ESTIMATE- GENERATIONtm



Latest Solution: SureSource 4000

SMARTGEN21

Electricity Generation and Storage for the 21st Century



MW-Class Distributed Generation with Combined Cycle Electrical Efficiencies

	FuelCell Energy	Combined cycle gas plant
Size	1.4 MW to 100 MW	400+ MW <i>(scale req'd for high efficiency)</i>
Construction/Siting	Months; site WITHIN cities	Years; site AWAY FROM cities
Electrical Efficiency	Plant efficiency: 47-60% Transmission losses: <u>None!</u> Delivered efficiency: 47-60%	Plant efficiency: 55-60% Transmission losses: <u>(6-9%)</u> Delivered efficiency: 46-54%
Clean Emission Profile <i>(virtually zero NO_x, SO_x, or PM)</i>	Yes ✓	No ✗
Renewable Fuel Option/REC's	Yes ✓	No ✗
Combined Heat & Power	Yes ✓	Limited ✗
Scalable	Yes ✓	No ✗
Support Urban Redevelopment	Yes ✓	No ✗
Affordable Carbon Capture	Yes ✓	No ✗
		

3.7 MW Enhanced- Efficiency Fuel Cell Power Plant Configuration

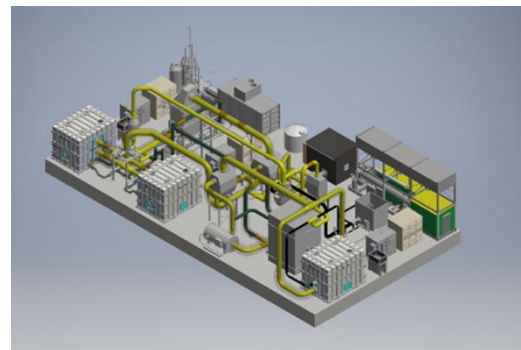

COST ESTIMATE- GENERATION

Examples given ~ 50 MW plant configurations
Contract to commissioning, 12-15 months.

	SureSource3000	SureSource4000
Number of Units	18	14
Total MWs	2.8	3.7
Capital Cost (USD/kW)	50.4	51.8
Total Capital Cost (USD 000s)	\$136,584	\$169,541
Shipping est. (USD 000s)	\$2,000	\$2,000
EPC est. (USD 000s)	\$22,680	\$22,680
Total Estimated Pricing (USD 000s)*	\$161,264	\$194,221
Total Estimated Pricing (USD/kW)	\$3,200	\$3,749

*Information supplied by FuelCell Energy, Inc. (NASDAQ: FCEL), 3 Great Pasture Rd., Danbury, Connecticut, 06810, U.S.A.

These are Direct Molten Carbon Fuel Cells (DMCFC) that use Natural Gas as the fuel. Thus, one must consider the Heat Rate in looking at comparing technologies for what is currently a very scarce and expensive fuel :

- Torrens Island 'A' Power Station Heat Rate : 12.5 GJ / MWh,
- Torrens Island 'B' Power Station Heat Rate : 11.5 GJ / MWh,
- DMCFC Heat Rate : 6.1 GJ / MWh^{#2},
- Waste Heat from the DMCFCs would be reused in an Organic Rankin Cycle Turbine (which are 'off the shelf' industrial units).

Note : #2 – Based upon Lower Heating Value (LHV), based upon Higher Heating Value (HHV) = 4.8 GJ / MWh



In comparison, the Heat Rate quoted for the Wartsila W18V50DF Dual Fuel Reciprocating Gensets is = 8.620 GJ / MWh (hvh).

COST ESTIMATE- GENERATION

So, in fuel terms let us make some assumptions for the sake of comparison:

- Plant Size 100 MW,
- Capacity Factor 95% (enhanced by suitable Storage),
- Hours in one year : 8,760 hrs,
- Assumed Natural Gas price (South Australia, Base Load) \approx A\$12.00 / GJ,
- Therefore, annual MWhr : $100 * 0.95 * 8,760 = 832,200$ MWh.,
- Therefore Fuel cost:
 - For 100 MW at Torrens Island 'A' Power Station : $832,200 \text{ MWh} / \text{year} * 12.5 \text{ GJ} / \text{MWh} * \text{A\$}12.00 / \text{GJ} = \text{A\$ } 124,830,000 / \text{year}$,
 - For 100 MW at Torrens Island 'B' Power Station : $832,200 * 11.5 * 12.00 = \text{A\$ } 114,843,600 / \text{year}$,
 - For 100 MW **DMFC Adaptive Power Plant** : $832,200 * 4.8 * 12.00 = \text{A\$ } 47,934,720 / \text{year}$,
 - For 100 MW Dual Fuel Reciprocating Gensets : $832,200 * 8.62 * 12.00 = \text{A\$ } 86,082,768 / \text{year}$.



Sumitomo Electric Confidential

Proposal for 6MWh VFB System

Our Ref. No: ESD-17-001

SUMITOMO ELECTRIC INDUSTRIES, LTD.

6th, Apr., 2017

“The Transformative Power Plant” Technology Concept 2

SMARTGEN21

Electricity Generation and Storage for the 21st Century

Transformative Power
Plant – *SMARTGEN21*
Victoria

The Transformative Power Plant - SMARTGEN21

The Optional Use Of Solid Oxide Fuel Cell Technology



HYBRID-FC

Mitsubishi Hitachi Power Systems (MHPS)

Solid Oxide Fuel Cells (SOFC) are operated under high temperatures and form a high-efficiency power generating system when combined with Micro Gas Turbines in one unit.

Current Product line up :

HYBRID-FC 250kW class
HYBRID-FC 1000kW class

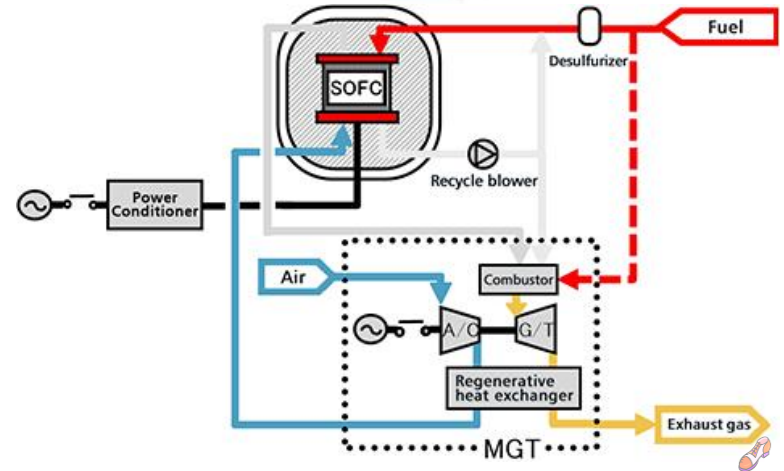
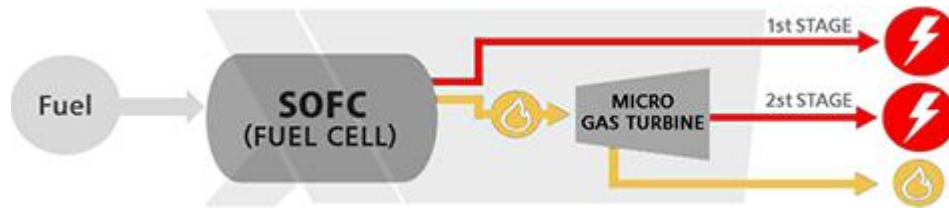

The Transformative Power Plant - SMARTGEN21

The Optional Use Of Solid Oxide Fuel Cell Technology



Mitsubishi Hitachi Power Systems (MHPS)

HYBRID-FC

Pressurization-type SOFC Module

The hybrid system is made up of a fuel system (red line in figure), air system (blue line) and exhaust gas system (yellow line). Fuel gas passes through the desulfuriser to remove its Sulphur content, and is then inserted into the SOFC after being pressurized in a compressor. Meanwhile, air is inserted into the SOFC after being pressurized through the MGT. Exhaust fuel from the SOFC is pressurized by a recirculating blower. Then, part of it is returned to the SOFC, with the remainder inserted into the combustor chamber of the MGT together with exhaust air. The exhaust gases combusted in the combustion chamber undergo heat exchange with air sent to the SOFC by means of a regenerative heat exchanger, and after heated water and steam have been produced with the exhaust heat recovery unit, the exhaust is released into the air.

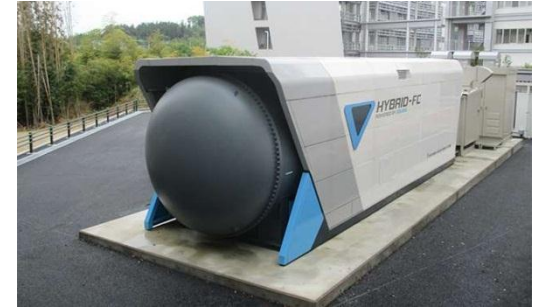

Tokyo Gas Co., Ltd. Senju Techno Station Demonstration: Model 10 Hybrid Power Generation System achieved continuous operation for 4,100 hours (September 2013)

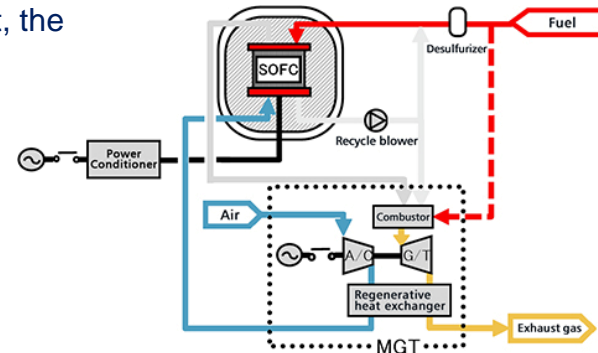

The Transformative Power Plant - SMARTGEN21

The Optional Use Of Solid Oxide Fuel Cell Technology



Mitsubishi Hitachi Power Systems (MHPS)

HYBRID-FC

Multiple Fuel Cells (single cells) are connected in series on the outside of substrate tube (ceramic) to form Cell stacks, which is bundled to create cartridges (with outputs of several dozen kW). These cartridges are gathered together and stored in a pressure vessel. This configuration is collectively referred to as a "module." Adopting this sort of layered structure offers easy installation and maintenance. In addition, since electrical output can be adjusted depending on the number of cartridges or modules, it is possible to supply the right amount of electricity as needed.

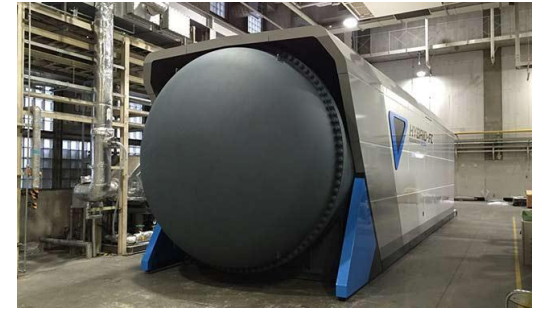
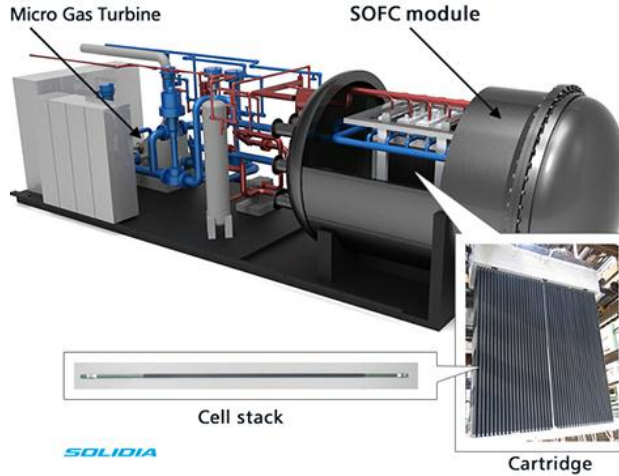

*Kyushu University Ito Campus
Demonstration: Model 15 Hybrid Power
Generation System achieved cumulative
operating time of 10,000 hours (October
2016)*



The Transformative Power Plant - SMARTGEN21

The Optional Use Of Solid Oxide Fuel Cell Technology



Mitsubishi Hitachi Power Systems (MHPS)

HYBRID-FC

Module

A structure with cartridges gathered together and stored within a pressure vessel.

Cartridge

A bundle of Cell stacks that functions as a bearing member, supplies and discharges fuel and air, and collects current.

Cell Stack

Elements that react to power generation (Fuel Cell stack of fuel electrodes, electrolyte and air electrodes) are formed on the outer surface of a substrate tube that serves as a structural member made from highly-strengthened ceramic. As elements are connected in a series with inter-connectors made from electronically conductive ceramic, high voltage electrical output can be efficiently collected at low currents.

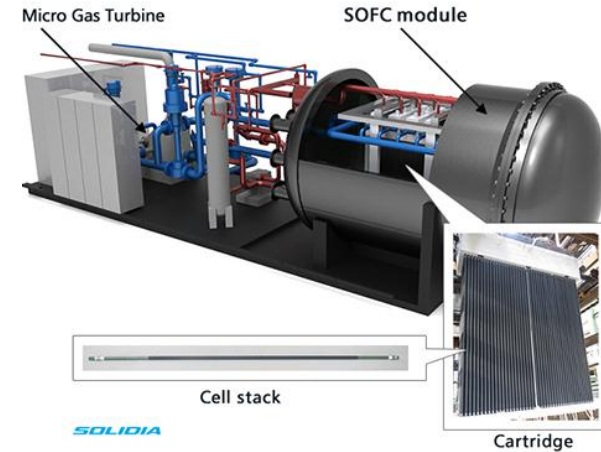

The Transformative Power Plant - SMARTGEN21

The Optional Use Of Solid Oxide Fuel Cell Technology



Mitsubishi Hitachi Power Systems (MHPS)

HYBRID-FC

An integrated power generating system comprising SOFC + Gas Turbines + Steam Turbines shows promise for high-efficiency power generation as future replacement for thermal power plants in future large-scale projects.

A transmission end-power generation efficiency of more than 70 percent (lower heating value, LHV) can be expected from a future natural gas-fired 100-megawatt-class SOFC + gas turbine + steam turbine combined-cycle system (gas turbine fuel cell combined cycle, or GTFC, Figure 1), which is positioned as a future replacement for large-scale thermal power plants. This will enable carbon dioxide (CO₂) emissions from thermal power stations to be reduced by around 20%. Even when coal is used as fuel, a transmission end-power generation efficiency of more than 60 percent (LHV) can be expected in 100-megawatt-class integrated coal gasification + SOFC + gas turbine + steam turbine combined-cycle systems (integrated coal gasification fuel cell combined cycle, or IGFC, Figure 2), and similarly, this would allow CO₂ emissions to be reduced by around 30%.

MHPS will lead the technological development of fuel cells and aim to achieve even higher capacity and efficiency gains, culminating in the development of actual systems for utility use.



Concept for a large Power Plant based upon Solid Oxide Fuel Cells (SOFC)



The Transformative Power Plant - SMARTGEN21

SMARTGEN21

Electricity Generation and Storage for the 21st Century

GENERATION + STORAGE

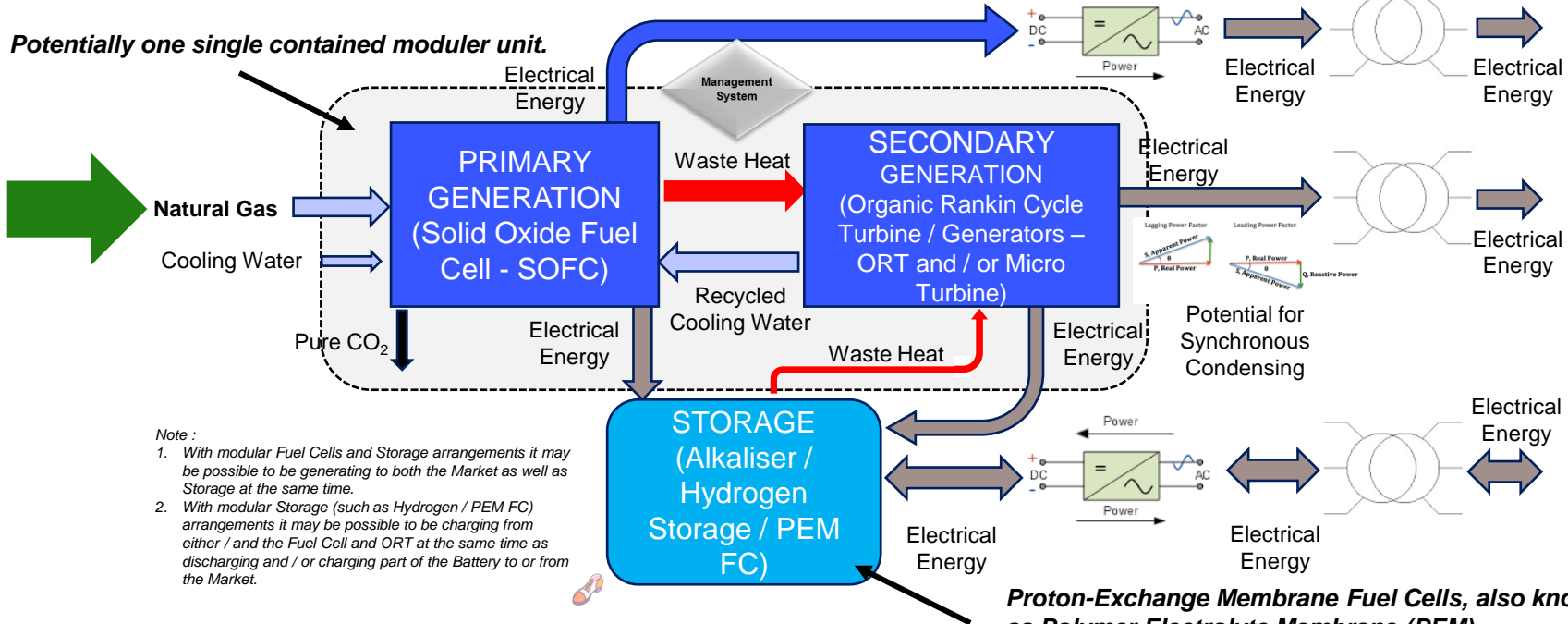

Note:

1. With modular Fuel Cells and Storage arrangements it may be possible to be generating to both the Market as well as Storage at the same time.
2. With modular Storage (such as Hydrogen / PEM FC) arrangements it may be possible to be charging from either / and the Fuel Cell and ORT at the same time as discharging and / or charging part of the Battery to or from the Market.

Proton-Exchange Membrane Fuel Cells, also known as Polymer Electrolyte Membrane (PEM) Fuel Cells (PEMFC).

The Transformative Power Plant - SMARTGEN21

An Opportunity For Hydrogen Energy Storage and Fuel Cell Technology

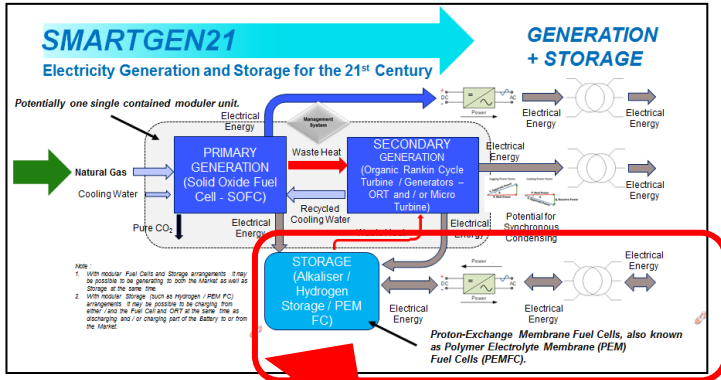

TOSHIBA
Leading Innovation >>>

H₂One™

Hydrogen-based autonomous energy supply system

Hydrogen Energy Storage System Large Capacity Hydrogen Energy Storage System



In the **Transformative Power Plant – SMARTGEN21** Concept (illustrated on the previous slide), there is a need for Energy Storage. at potentially Grid scale. This may take a number of forms:

1. Battery Technology such as Lithium – Ion,
2. Redox Flow Batteries,
3. Hydrogen – FC ,
4. ...

Toshiba may have technologies that could play a role in such a Plant,



The Transformative Power Plant - SMARTGEN21

An Opportunity For Hydrogen Energy Storage and Fuel Cell Technology

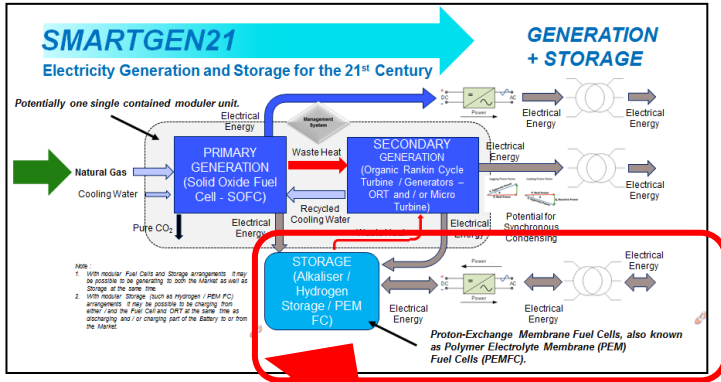

TOSHIBA
Leading Innovation >>>

H₂One™
Hydrogen-based autonomous
Energy supply system

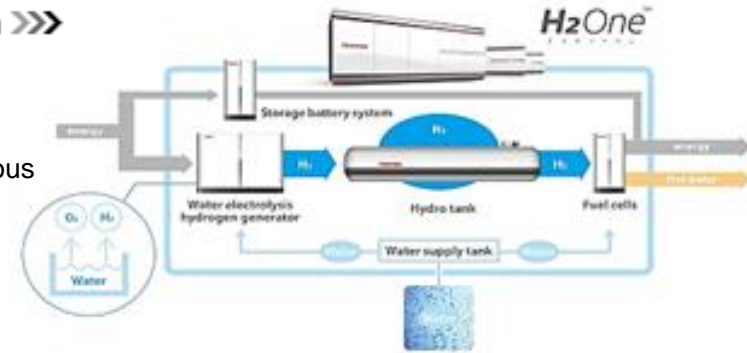

Hydrogen Energy Storage System

Large Capacity Hydrogen Energy Storage System



Potential Site

Jeeralang Open Cycle Gas Turbine Power Station, La Trobe Valley, Victoria

Jeeralang Power Station is a gas turbine power station with a capacity of 460 megawatts (620,000 hp) near Morwell, Victoria, Australia. The station is a peaking facility which is used only during periods of peak demand, and is also used as a black start facility to restore power to the grid in the event of major system failure. As a result, the actual capacity factor of the station is less than 5%. The power station was built by the State Electricity Commission of Victoria in response to the scaling back of Newport D power station from 1,000 megawatts (1,300,000 hp) to 500 megawatts (670,000 hp), as a result of community concerns and union bans. Jeeralang consists of seven gas turbines configured to operate in single cycle mode.

Jeeralang A was built between 1977 and 1979 and consists of four Siemens Industries V93.1 gas turbines with a combined capacity of 220 megawatts (300,000 hp).

Jeeralang B was built between 1978 and 1980 and consists of three Alstom Atlantique MS-9001 gas turbines with a combined capacity of 240 megawatts (320,000 hp).[3]

The power station is currently operated by Ecogen Energy.

*Jeeralang 'A'
Power Station*

*Jeeralang 'B'
Power Station*



Potential Site

Jeeralang Open Cycle Gas Turbine Power Station, La Trobe Valley, Victoria



Potential Site

Jeeralang Power Station(s) – Potential Expansion on Site

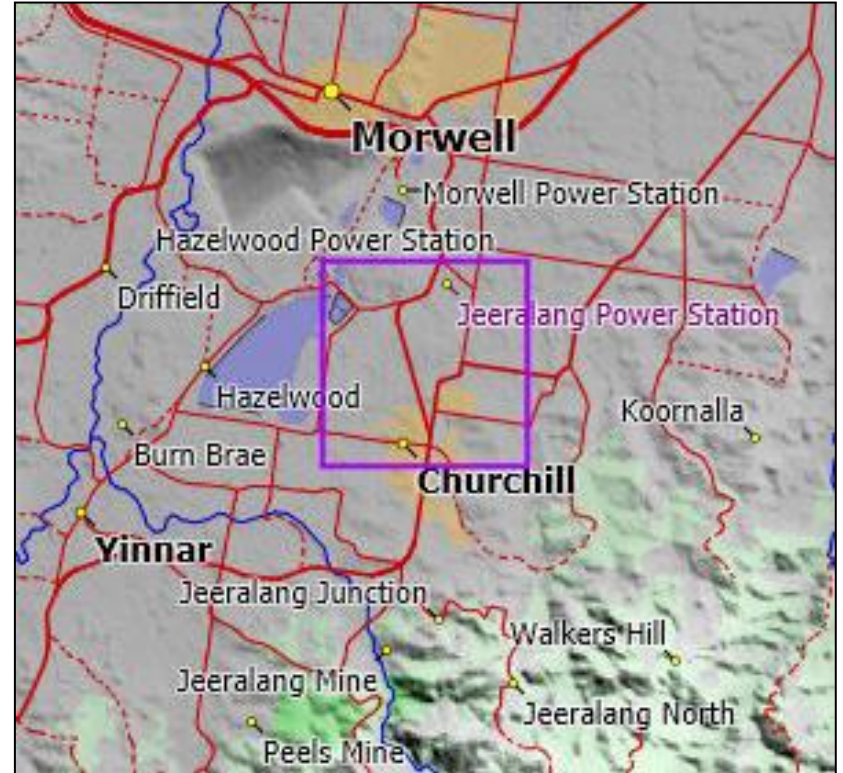

Potential Site

Jeeralang Open Cycle Gas Turbine Power Station, La Trobe Valley, Victoria

Why Jeeralang ?

1. Existing Gas Fired Power Station site (“Brownfield”),
2. Large area of flat land on the site,
3. High Pressure Natural Gas connection,
4. Ideally located nearby the Hazelwood Terminal Station allowing ease of High Voltage Transmission connection,
5. Existing site infrastructure and systems,
6. Victorian Government desire for Storage Capacity in the La Trobe Valley,
7. Site current up for sale.



Potential Site

Jeeralang Power Station(s) - Land

Jeeralang is about 6 km south of the town of Morwell. The site is an open rural area of approximately 28 hectares (Ha) and is isolated from the nearest residents by a large buffer zone. The freehold title is currently owned by Ecogen.

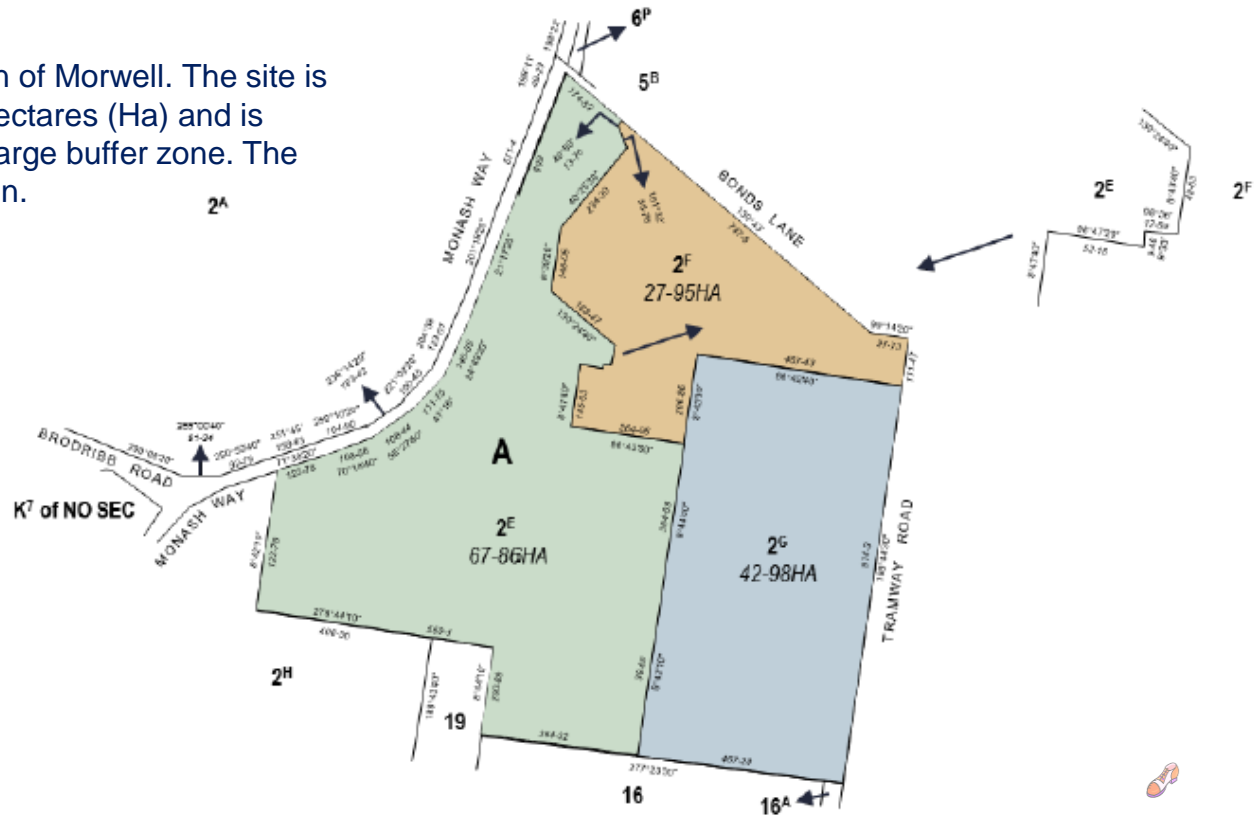

Potential Site

Jeeralang Power Station(s) - Land

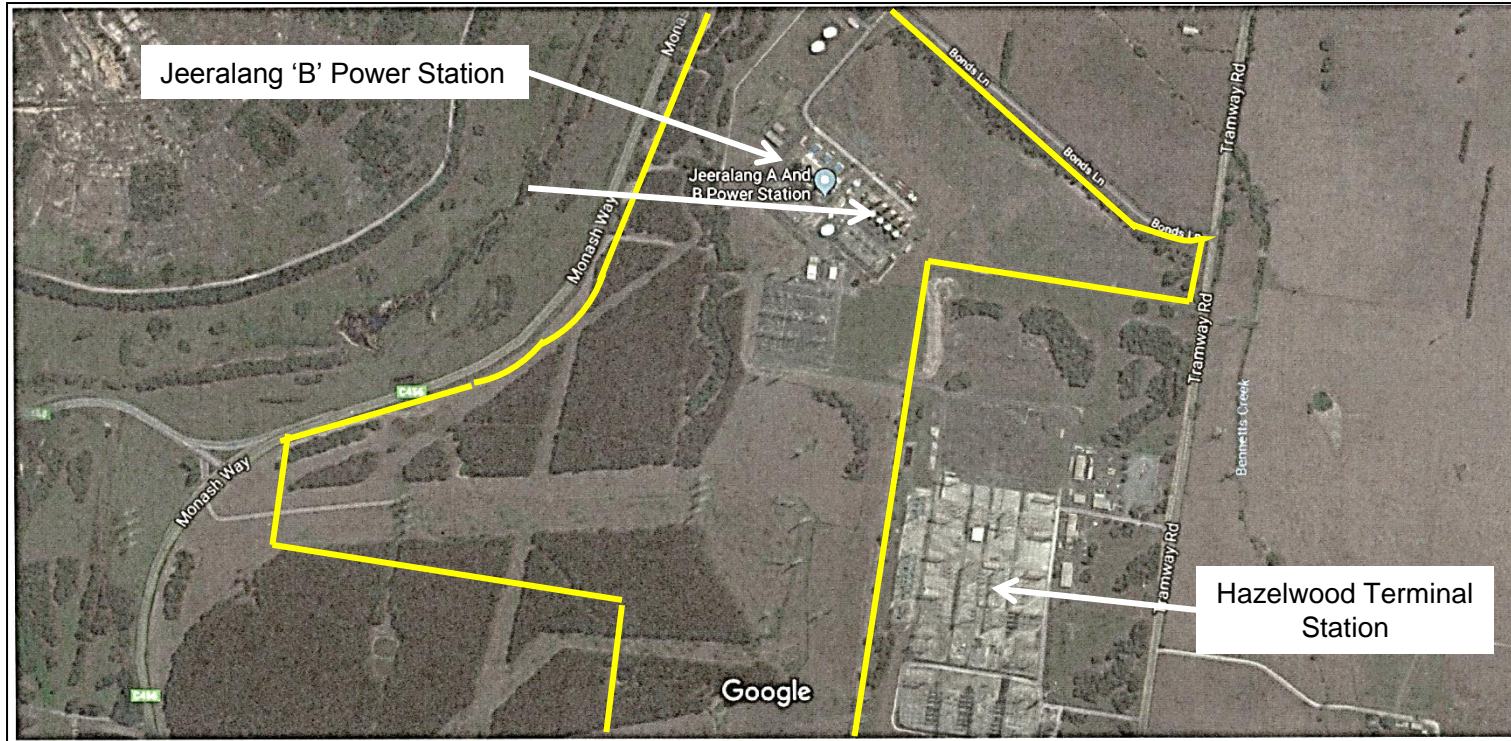

Potential Site

Jeeralang Power Station(s) – Potential Expansion on Site

Jeeralang Expansion

The Jeeralang title features significant additional land to the north of the plant that could accommodate further generation capacity as shown in the figure on right. Jeeralang is immediately adjacent to and connected to the Jeeralang Terminal Station (220 kV) and very close to the Hazelwood Terminal Station (220 kV and 500 kV). The Hazelwood Terminal Station represents the main hub for transmission of power from the La Trobe Valley to the main load centre in Melbourne and the rest of the NEM.

This site was reviewed at a high-level was carried out for Ecogen by Jacobs in 2011 for a possible Combined Cycle Gas Turbine (CCGT) expansion as a counter-point for a potential expansion evaluation at the Newport site. At this time it was envisaged that new significant power generation in Latrobe Valley should connect to the 500 kV system. However, given the subsequent retirement of the Hazelwood Power Station it could also be investigated whether a new unit could connect to the 220 kV system instead. Hazelwood Power Station has four 220 kV circuits into Hazelwood Terminal Station and four 220 kV circuits into Jeeralang Terminal Station.

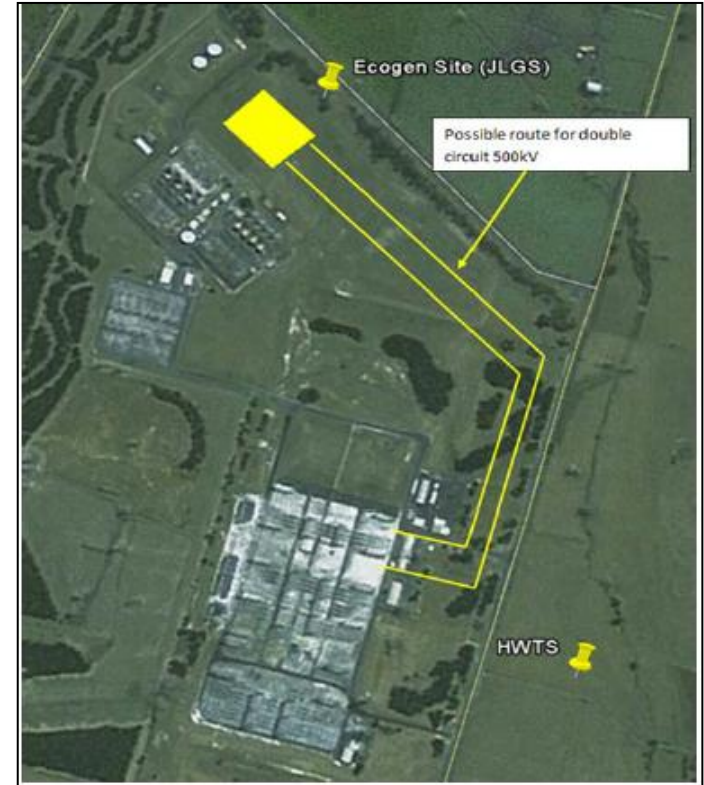

Potential Site

Jeeralang Power Station(s) – Potential Expansion on Site

Jeeralang Expansion

The Jeeralang site, including the identified area, is zoned for power station use. The area has substantial infrastructure to support additional power generation including the natural gas main transmission system to Melbourne passing just north of Morwell and the electricity transmission system as noted. There is also the potential to consider evaporative cooling of a CCGT unit given that the Hazelwood Power Station is no longer in service and was water cooled.

Energy Storage Possability

Considering the location of the 220 kV and 500 kV connection options and the Jeeralang land area, another enhancement option to consider would be Energy Storage. This could take advantage of possible future developments in Energy Storage technology and costs, and the increasing drivers for Energy Storage as intermittent forms of electricity generation increase penetration in the NEM.

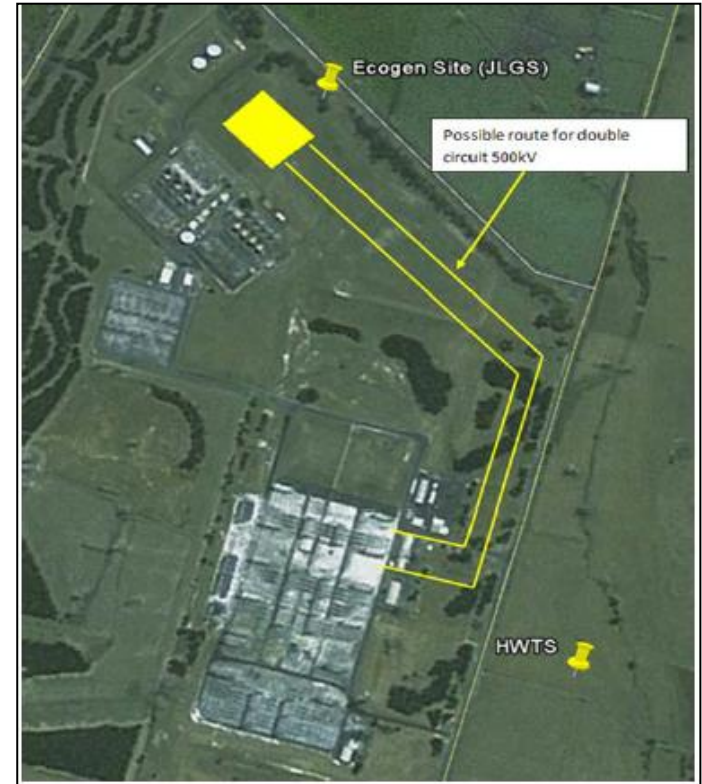

The Transformative Power Plant - SMARTGEN21

The Optional Use Of Solid Oxide Fuel Cell Technology on Jeeralang Site

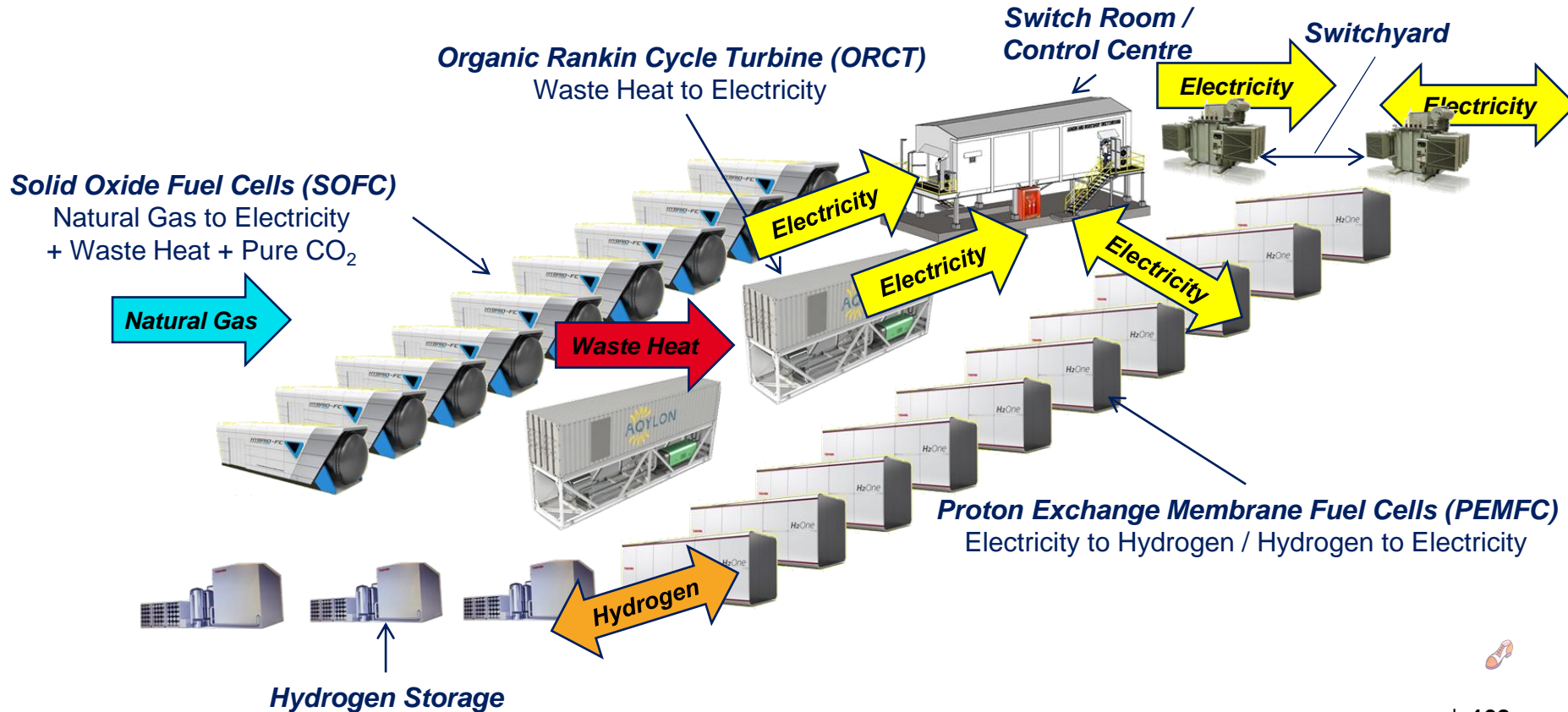

The Transformative Power Plant - *SMARTGEN21*

The Scope

- **15 to 100 MW Direct Fuel Cell Generation,**
 - ✓ **Natural Gas Fueled,**
 - ✓ **60% Efficient, - Highest in Australia,**
 - ✓ **Low CO₂ Emission, - 0.25 tCO₂-e / MWh, Lowest in Australia#1,**
- **60 MWh Redox Flow Battery, - Safe and Environmentally Friendly,**
- **Speedy deployment through modular construction with “*near plug and play*”,**
- **Modular, progressive build up, sized and configuration to requirements,**
- **Combining Proven Technologies in a 21st Century Manner.**



The Transformative Power Plant - *SMARTGEN21*

The Scope

- **15 to 100 MW Direct Fuel Cell Generation,**
 - ✓ **Natural Gas Fueled,**
 - ✓ **60% Efficient, - Highest in Australia,**
 - ✓ **Low CO₂ Emission, - 0.25 tCO₂-e / MWh, Lowest in Australia#1,**
- **60 MWh Redox Flow Battery, - Safe and Environmentally Friendly,**
- **Speedy deployment through modular construction with “*near plug and play*”,**
- **Modular, progressive build up, sized and configuration to requirements,**
- **Combining Proven Technologies in a 21st Century Manner.**



The Transformative Power Plant - SMARTGEN21

Fuel Cells

Why Consider Fuel Cells – Efficiency Example

When we consider “Spark Spread” between various Natural Gas fuelled Generation technologies : Open Cycle Gas Turbines (OCGT) (based upon GE GT13E2), Combined Cycle Gas Turbines (CCGT) and Direct Molten Carbonate Fuel Cells (DMCFC) (Fuel Cell). If one accepts a Natural Gas Price of A\$10 / GJ and typical figures (LHV). The various configurations are as follows :

OCGT - Efficiency approx 34.6%, Heat Rate approx 10.2 GJ / MWh, thus A\$102 / MWh,

CCGT - Efficiency approx 50.6%, Heat Rate approx 7.9 GJ / MWh, thus A\$79 / MWh,

DMCFC (no heat recovery) - Efficiency 60% (see attached), Heat Rate 6.1 GJ / MWh, thus A\$61 / MWh,

DMCFC (heat recovery) - Efficiency assume 80%, Heat Rate assume 2.1 GJ / MWh, thus A\$21 / MWh.

Low Emissions Example

Torrens Island ‘A’ Power Station Heat Rate : 12.5 GJ / MWh,

Torrens Island ‘B’ Station Heat Rate : 11.5 GJ / MWh,

SMARTGEN21 Generation Heat Rate : 6.1 GJ / MWh^{#2},

Waste Heat from the SMARTGEN21 Fuel Cells would be available for Heat Recovery via Organic Rankin Cycle Turbine that converts waste heat from the fuel cells into additional electricity.

Note : #2 – Based upon Lower Heating Value (LHV), based upon Higher Heating Value (HHV) = 4.8 GJ / MWh.

The Transformative Power Plant - SMARTGEN21

Fuel Cells

Great Improved Environmental Performance :

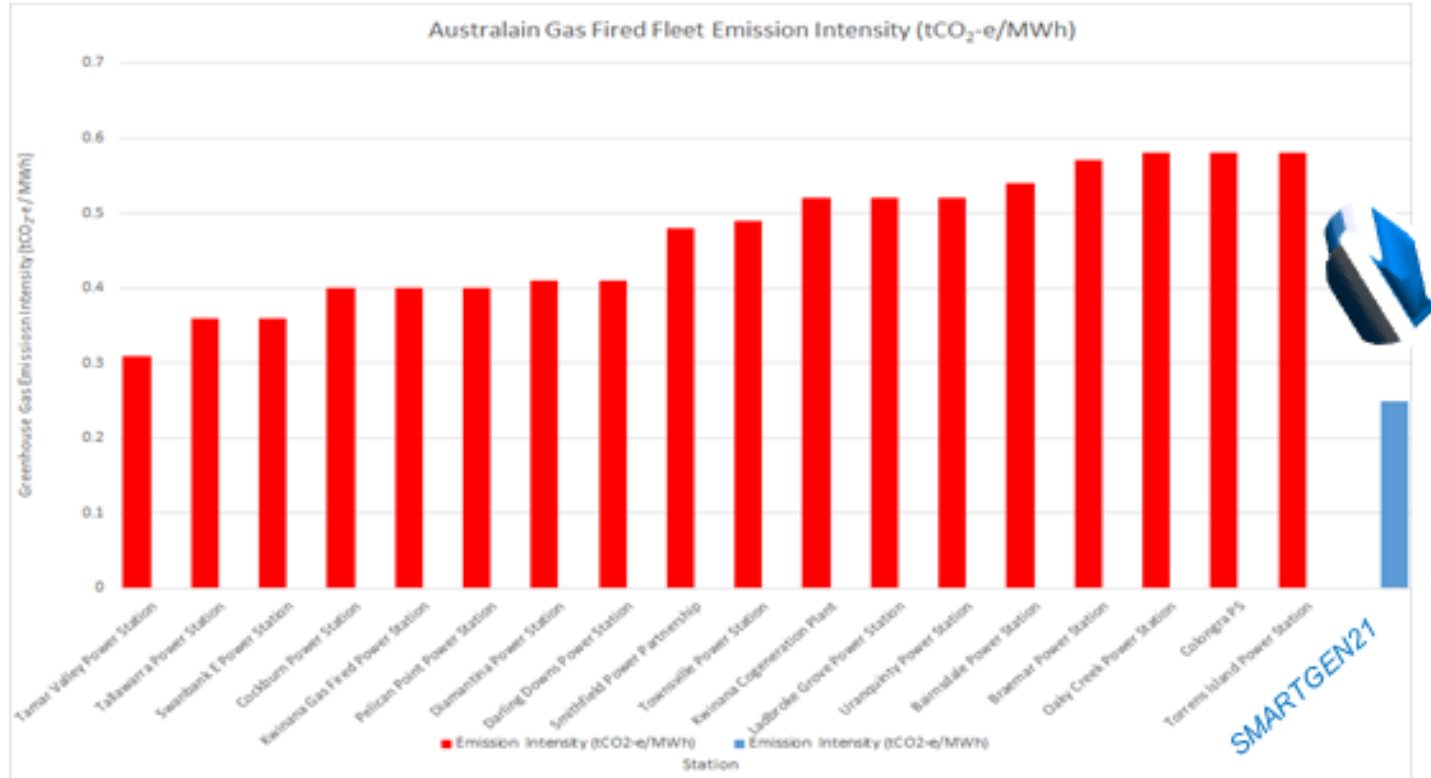

The Transformative Power Plant - *SMARTGEN21*

Hydrogen Energy Storage

Why Consider Hydrogen Energy Storage

- Potential to for large scale Energy ($\text{Nm}^3 \text{H}_2$ to MWh_e) Storage only limited by Gas Storage infrastructure,
- Adaptable Power to Energy ratios ($\text{MW}_e - \text{MWh}_e$),
- Alternative uses for Hydrogen,
- Long term Storage capability with no degradation,
- Rapid response,
- Plant life potentially very long,



New Hydrogen storage technology based on cast Magnesium alloys with novel microstructure to store Hydrogen as a solid metal Hydride.



Potential Site

Jeeralang Power Station(s) – Electricity Transmission Connection



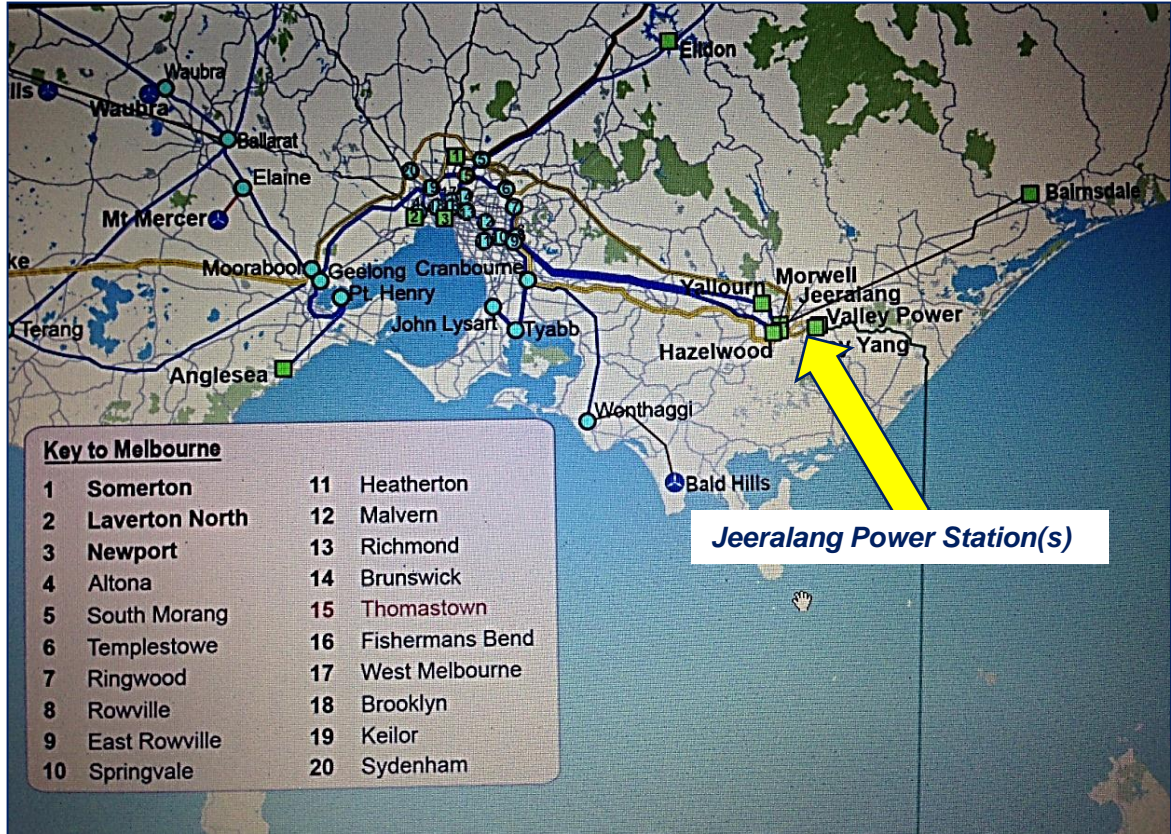



Transmission Lines	
	500 kV Transmission Line
	330 kV Transmission Line
	275 kV Transmission Line
	220 kV Transmission Line
	132 / 110 kV Transmission Line
	66 kV Transmission Line

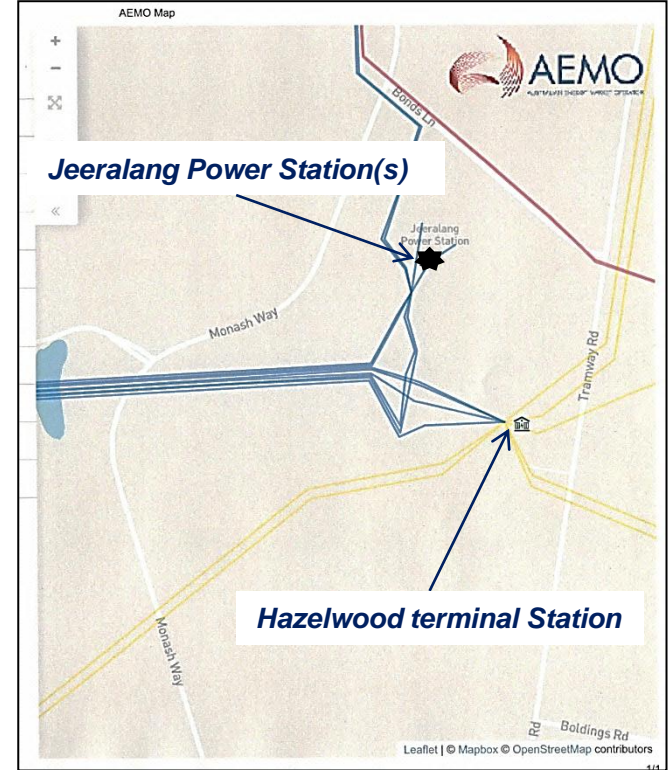
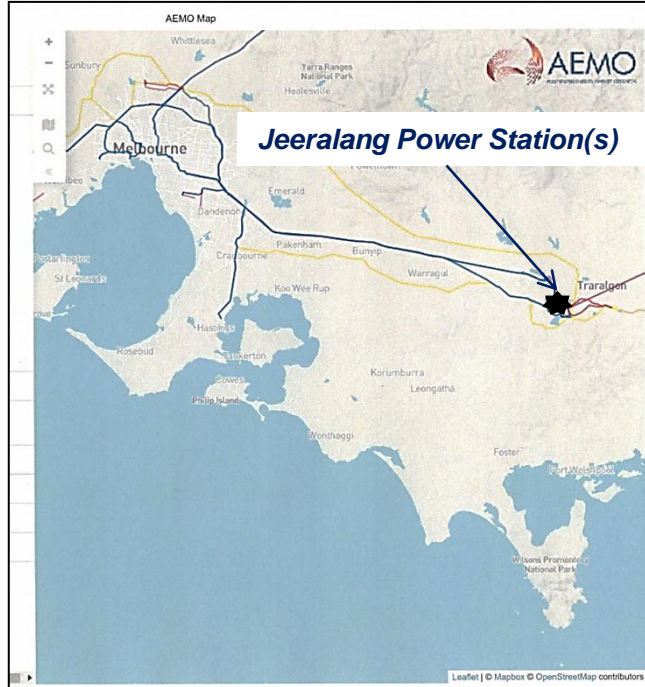
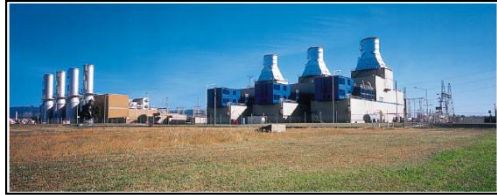

Potential Site

Jeeralang Power Station(s) – Electricity Transmission Connection



Transmission Lines	
	500 kV Transmission Line
	330 kV Transmission Line
	275 kV Transmission Line
	220 kV Transmission Line
	132 / 110 kV Transmission Line
	66 kV Transmission Line

Potential Site

Jeeralang Power Station(s) – Natural Gas Network Connection

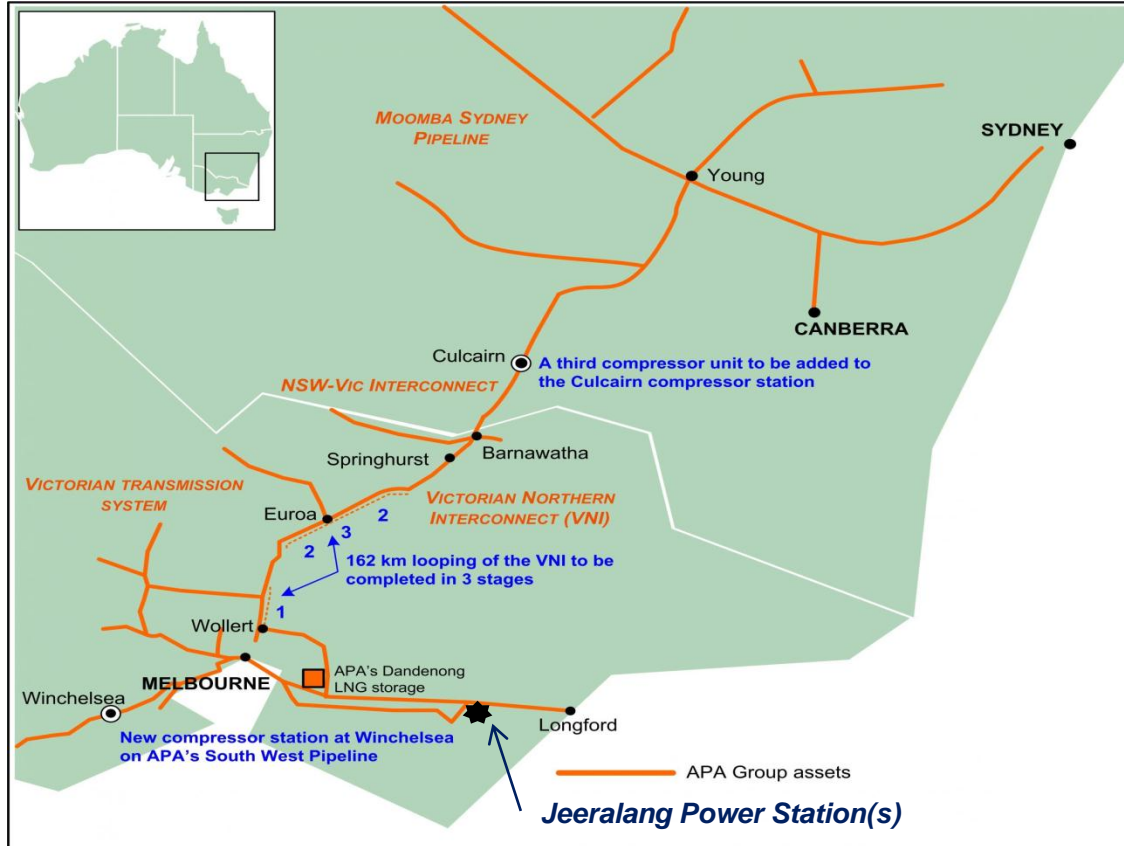

“The Transformative Power Plant” Technology Concept 2

SMARTGEN21

Electricity Generation and Storage for the 21st Century

Transformative Power
Plant – *SMARTGEN21*
New South Wales

Possible Site For A Transformative Power Plant

An ideal location for the initial Natural Gas fuelled **Transformative Power Plant**, co-location with an existing Natural Gas fuel plant with Gas connection infrastructure and Grid connection infrastructure would be ideal. Such a location would be Snowy Hydro's Colongra Gas Generation Plant in New South Wales. Colongra is a 667 MW Natural Gas which has generally be used during peak demand periods in New South Wales.

Colongra is an Open Cycle Gas Turbine (OCGT) plant consisting of four off GE 4 GT13E2s.

Snowy Hydro Colongra Power Station



GT13E2	2005	2012
SC Net Heat Rate (Btu/kWh, LHV)	9,027	8,980
SC NetHeat Rate (kJ/kWh, LHV)	9,524	9,474
SC Net Efficiency (% , LHV)	37.80%	38.00%
Comp. Pressure Ratio (X:1)	16.9	18.2
ExhaustTemperature (°F)	941	934
ExhaustTemperature (°C)	505	501
Exhaust Energy (MM Btu/hr)	1,055	1,155
Exhaust Energy (MM kJ/hr)	1,113	1,219
GT Turn-down - Minimum load (%)	30%	30%
GT Ramp Rate - (MW/minute)	12/25	14/36/38
NOx (ppmvd) at baseload (@15% O2)	25	15
CO (ppm) at min. turn-down w/o abatement	80	25
Wobbe Variation (%)	>+/- 20%	>+/- 20
Startup Time - Conventional / Peaking (min.)	25 / 15	25/15 / 10

Possible Site For A Transformative Power Plant

Snowy Hydro's Colongra Gas Generation Plant has the added advantage of significant extra land attached to the site as the result of the demolition of the 1,200 MW Lake Munmorah Coal Fired Power Station.

Snowy Hydro Colongra Power Station

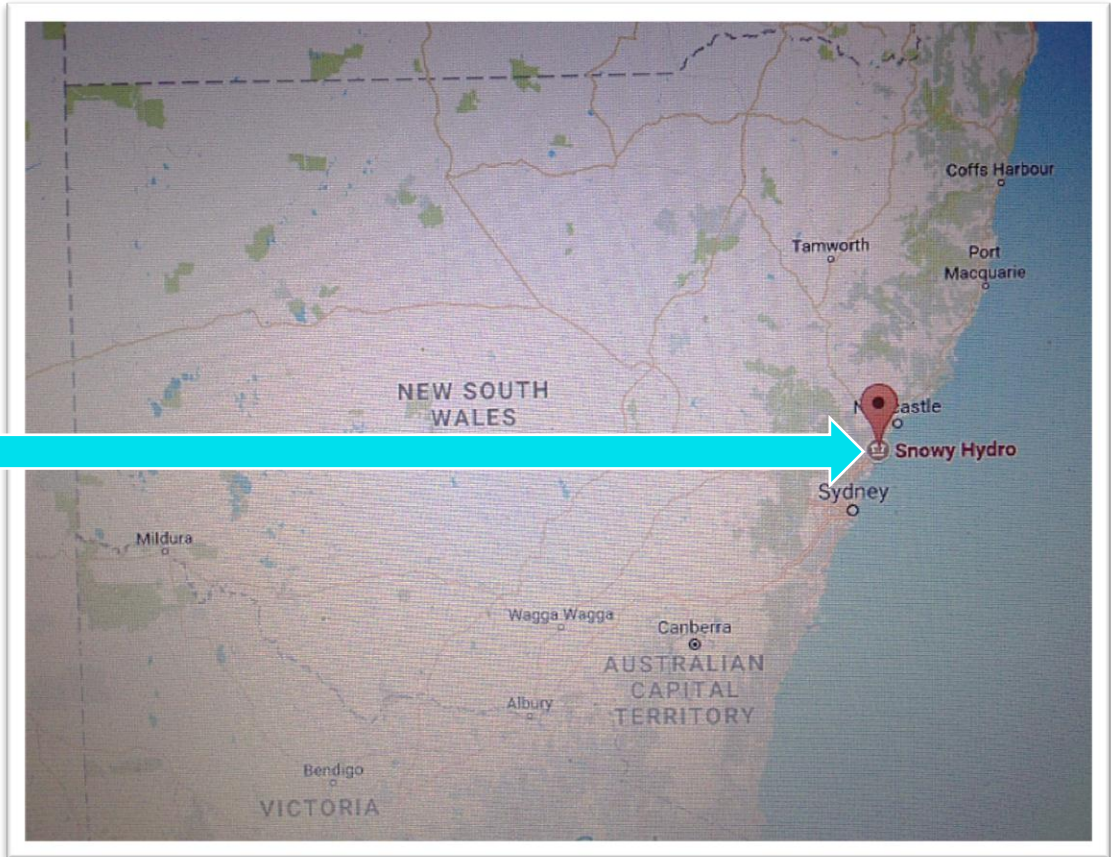

Possible Site For A Transformative Power Plant

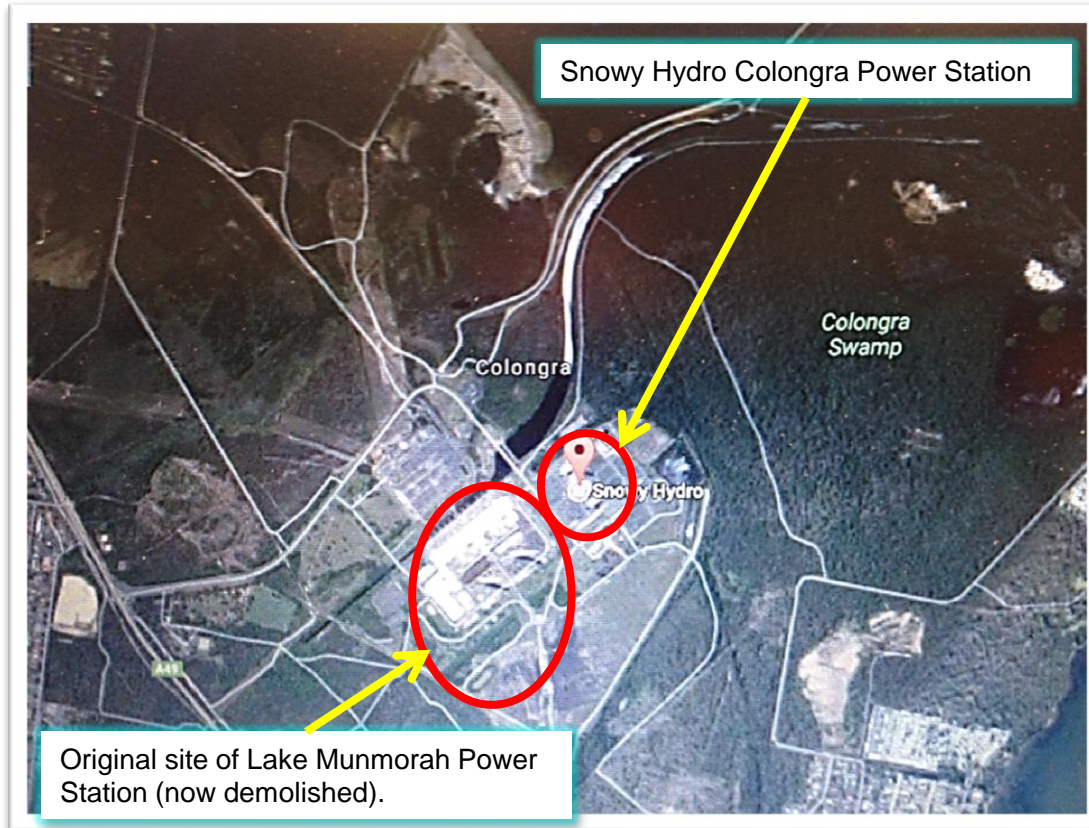

When we consider “Spark Spread” between various Natural Gas fuelled Generation technologies : OCGT (based upon GE GT13E2), CCGT and DMCFC (Fuel Cell). If one accepts a Natural Gas Price of A\$10 / GJ and typical figures (LHV). The various configurations are as follows :

OCGT - Efficiency approx 34.6%, Heat Rate approx 10.2 GJ / MWh, thus A\$102 / MWh,

CCGT - Efficiency approx 50.6%, Heat Rate approx 7.9 GJ / MWh, thus A\$79 / MWh,

DMCFC (no heat recovery) - Efficiency 60% (see attached), Heat Rate 6.1 GJ / MWh, thus A\$61 / MWh,

DMCFC (heat recovery) - Efficiency assume 80%, Heat Rate assume 2.1 GJ / MWh, thus A\$21 / MWh.



SMARTGEN21

21st Century Solution For Australia



“The Transformative Power Plant” Technology Concept 3

Transformative Power
Plant As Applied To
Improving Efficiency Of
Existing Thermal Plants

The Transformative Power Plant – A New Approach

Heat Recovery Generation / Storage

Taking existing Waste Heat from the Flue Gas stream and extracting Energy to Generate Electricity with the aim of Charging a Battery

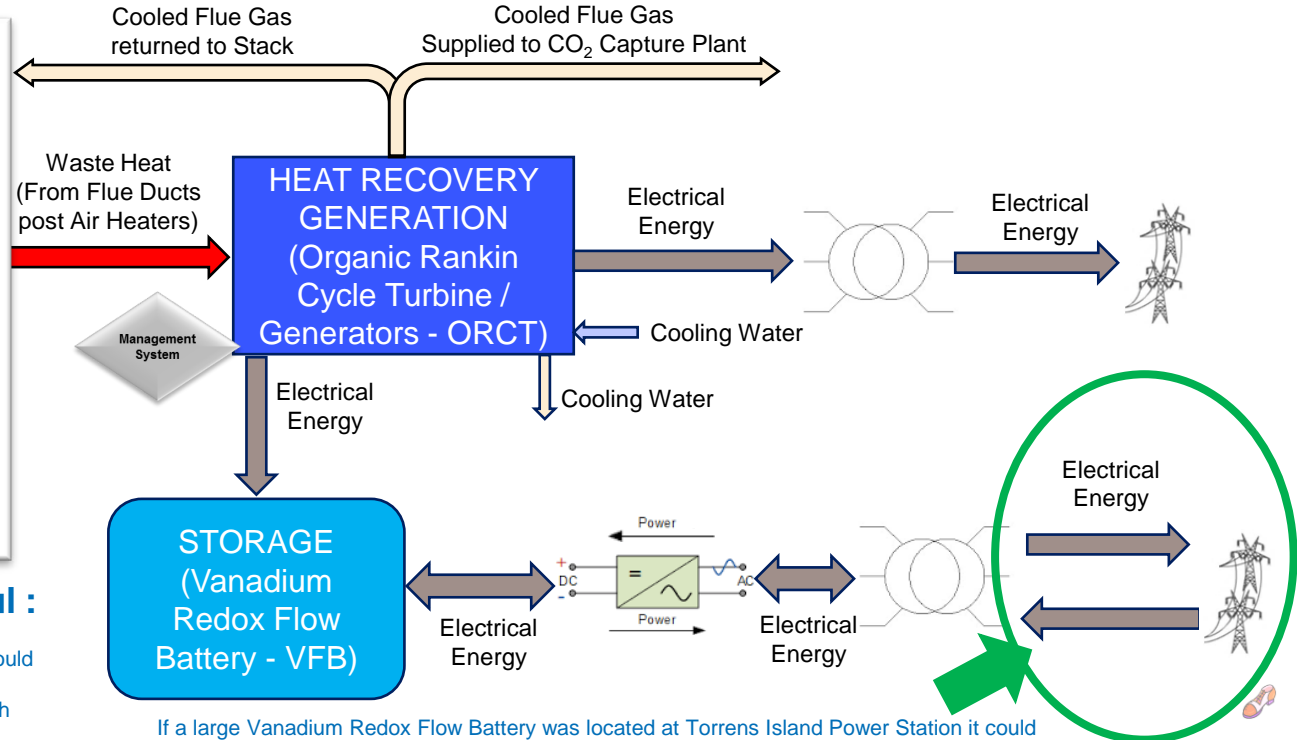
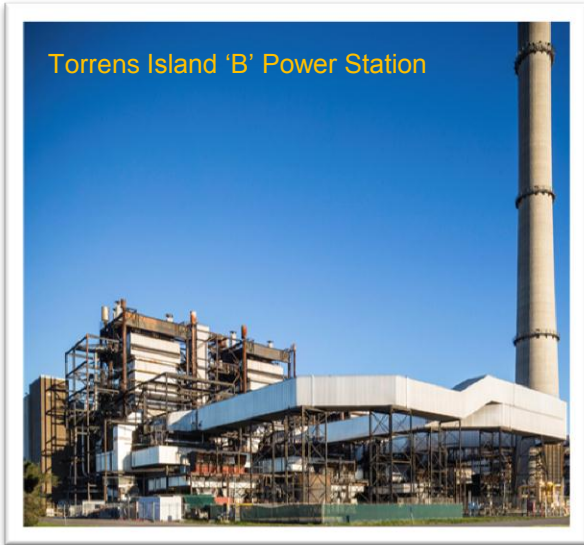

If Proof Of Concept was successful :

A correctly sized Heat Recovery Generation / Storage Plant could provide Torrens Island 'B' Power Station with Rapid Start Capability from Hot Condition via the VFB (200 MW / 500 MWh capacity) as well as provide "Synthetic Inertia".

If a large Vanadium Redox Flow Battery was located at Torrens Island Power Station it could also fore fill a role of "Renewables Firming" by drawing energy in from the Grid during high Renewables supply / low price periods and supply energy in low supply periods.

Transformative Power Plant - Improving Existing Plants

Potential Opportunity – AGL Torrens Island 'B' Power Station

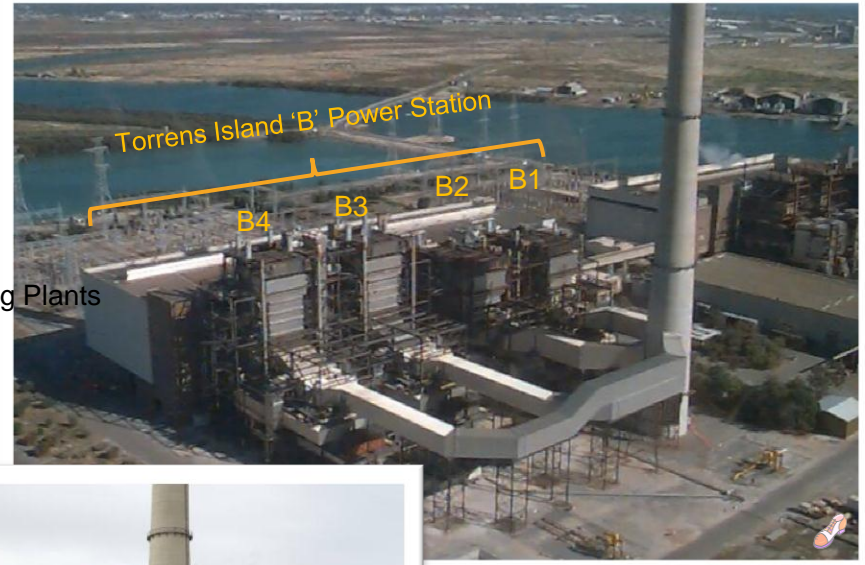
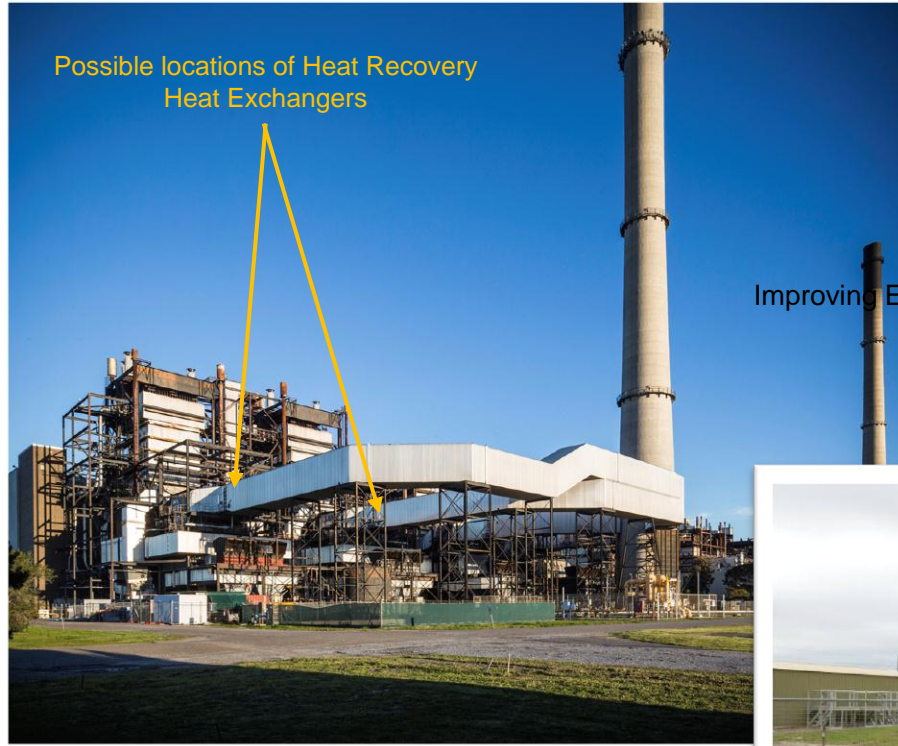

Note : Photographs date from before the fitting of extractions ducts for Air Liquid Torrens Island CO₂ Plant.



Transformative Power Plant - Improving Existing Plants

Air Liquid Torrens Island CO₂ Plant Flue Gas Off-Takes – Torrens Island 'B' Power Station

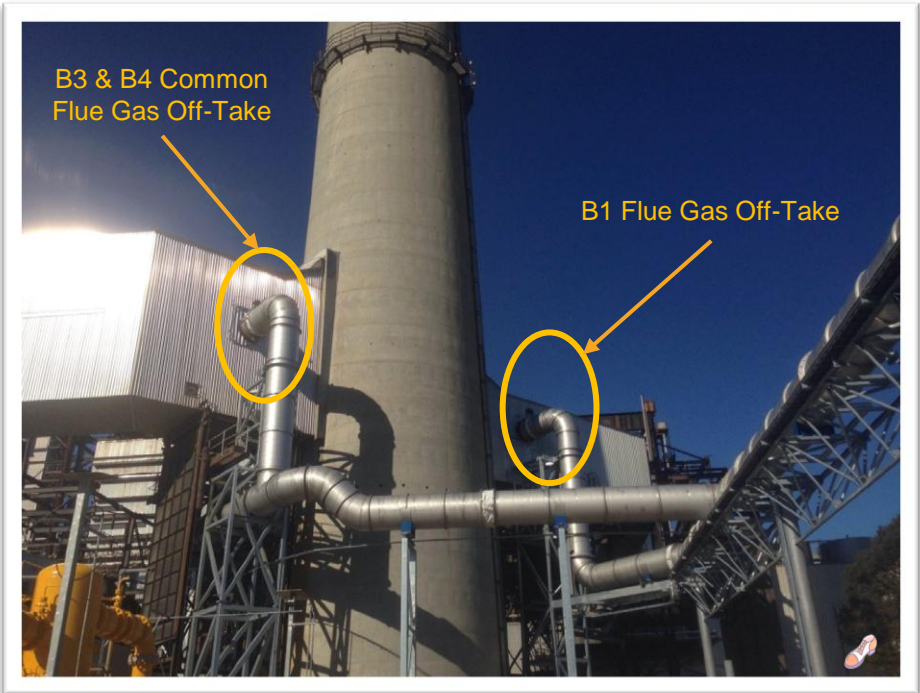

Transformative Power Plant – Improving Existing Plants

The use of such Technologies as Organic Rankin Cycle Turbine (ORCT)

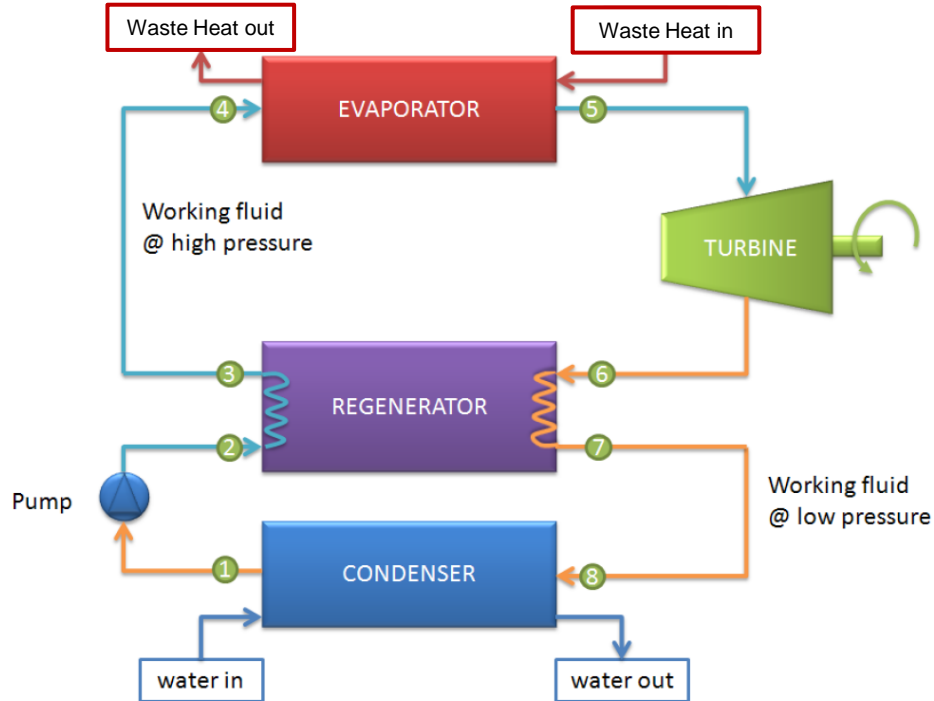

Typical Organic Rankin Cycle (ORC)

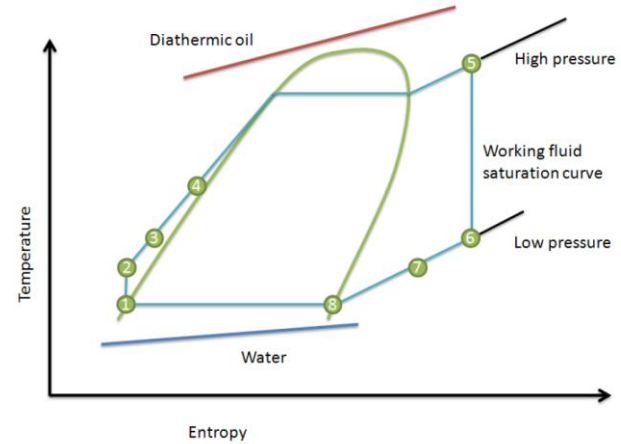

Typical Organic Rankin Cycle Turbine Thermodynamic States

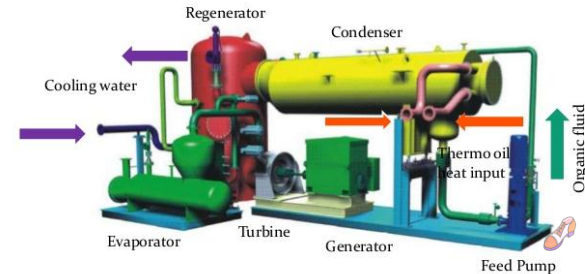

Typical Organic Rankin Cycle Turbine (ORCT) Components | 127

Efficiency Improvement Transformative Power Plant

Organic Rankin Cycle Turbine – Typical Containerised Unit

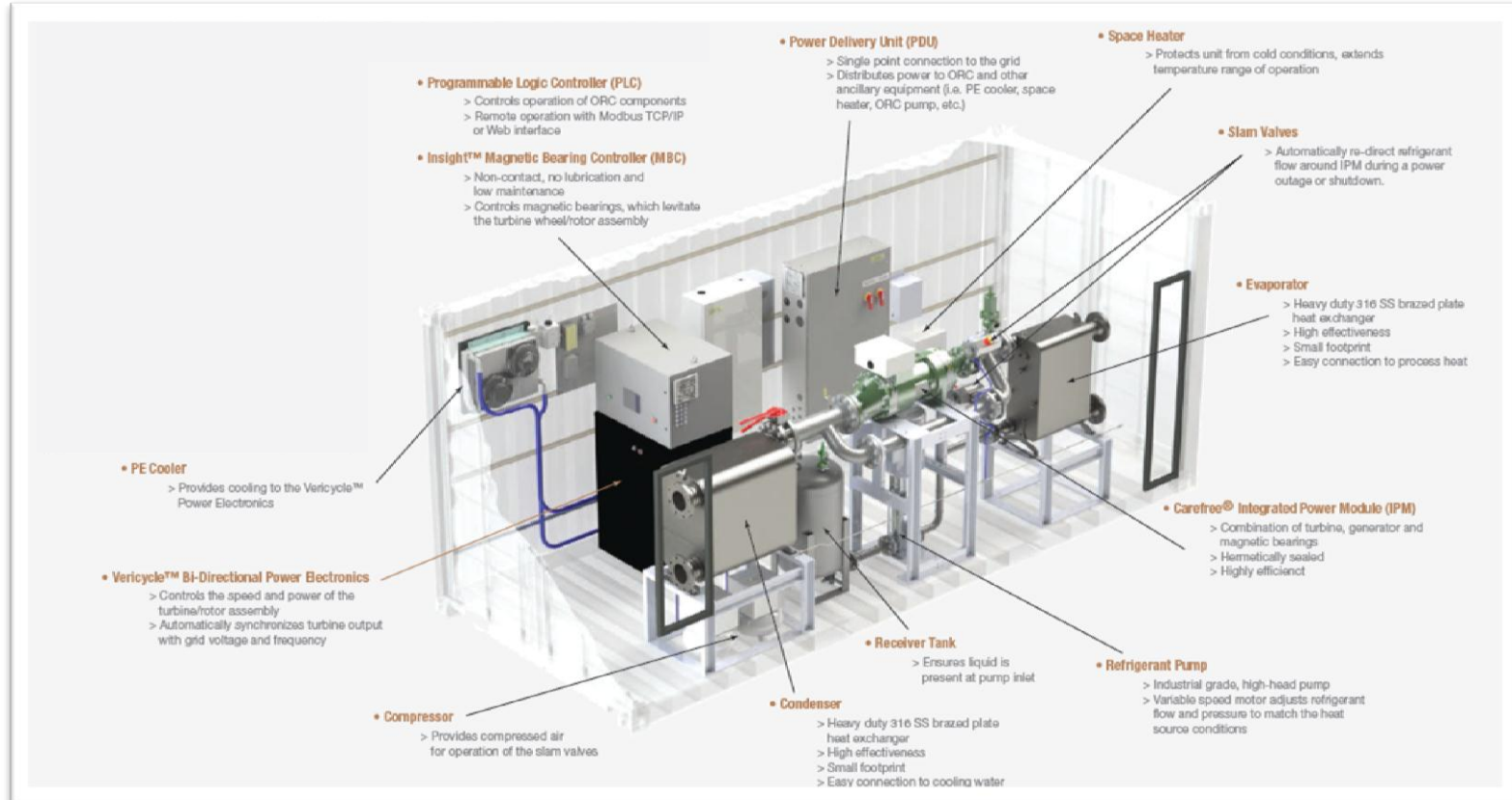

The Transformative Power Plant – A New Approach

GENERATION + STORAGE



GENERATION:
Organic Rankin Cycle Turbines recovery heat from Flue Gas



STORAGE:
Sumitomo Electric Redox Flow Battery



The Transformative Power Plant – A New Approach

Vanadium Redox Flow Batteries – An Australian Innovation

STORAGE

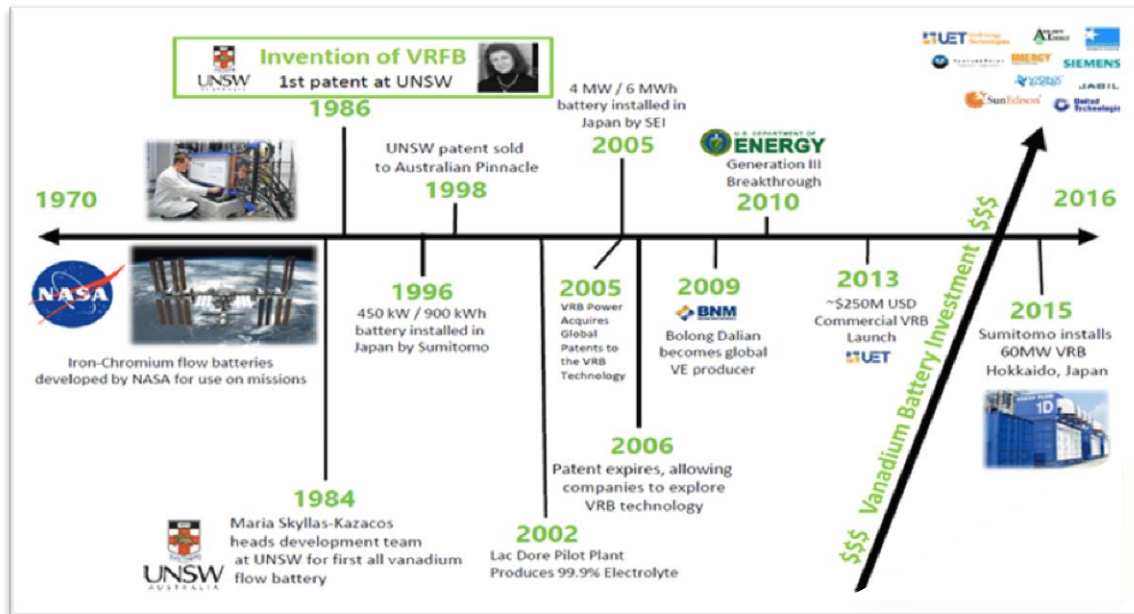



“The Transformative Power Plant” Technology Concept 3

Potential Site -
Newport, Victoria

Potential Site

Newport Gas Fired Rankin Cycle Power Station, Newport, Victoria

Newport Power Station is located in the suburb of Newport in Melbourne. Newport is a hub for industrial facilities, particularly petrochemical processing and oil storage along with residential and parkland areas. The Newport Power Station is situated on the west bank of the Yarra River immediately upstream of its discharge into Hobsons Bay and the northern-most arm of Port Phillip Bay. The site is 9.3 hectares of which approximately 7 hectares is owned freehold, with the remainder leased under a long-term arrangement from the Port of Melbourne (now administered by Hobsons Bay City Council).

Newport is a relatively flat site with a number of access points to the property along Douglas Parade as well as rear access via an extension of The Strand. There is a section of land to the north-east of Newport's property containing plant and equipment that is occupied by Ecogen under licence agreement.

The Newport site is currently zoned predominantly Industrial and part Public Park and Recreation as per the Hobsons Bay Planning Scheme. A minor segment of the southern portion of the site is subject to a Design and Development Overlay, restricting development to a maximum building height of two stories.



Potential Site

Newport Gas Fired Rankin Cycle Power Station, Newport, Victoria

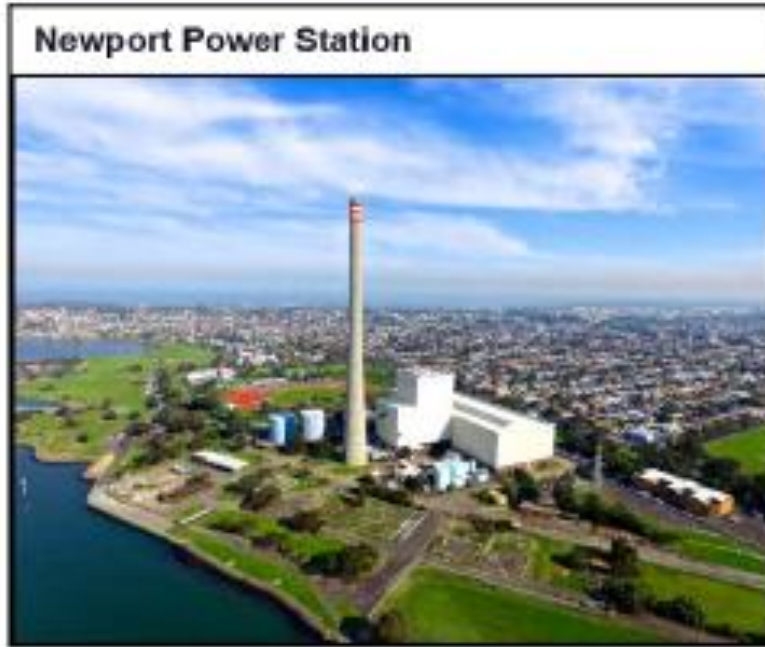

Potential Site

Newport Gas Fired Rankin Cycle Power Station, Newport, Victoria

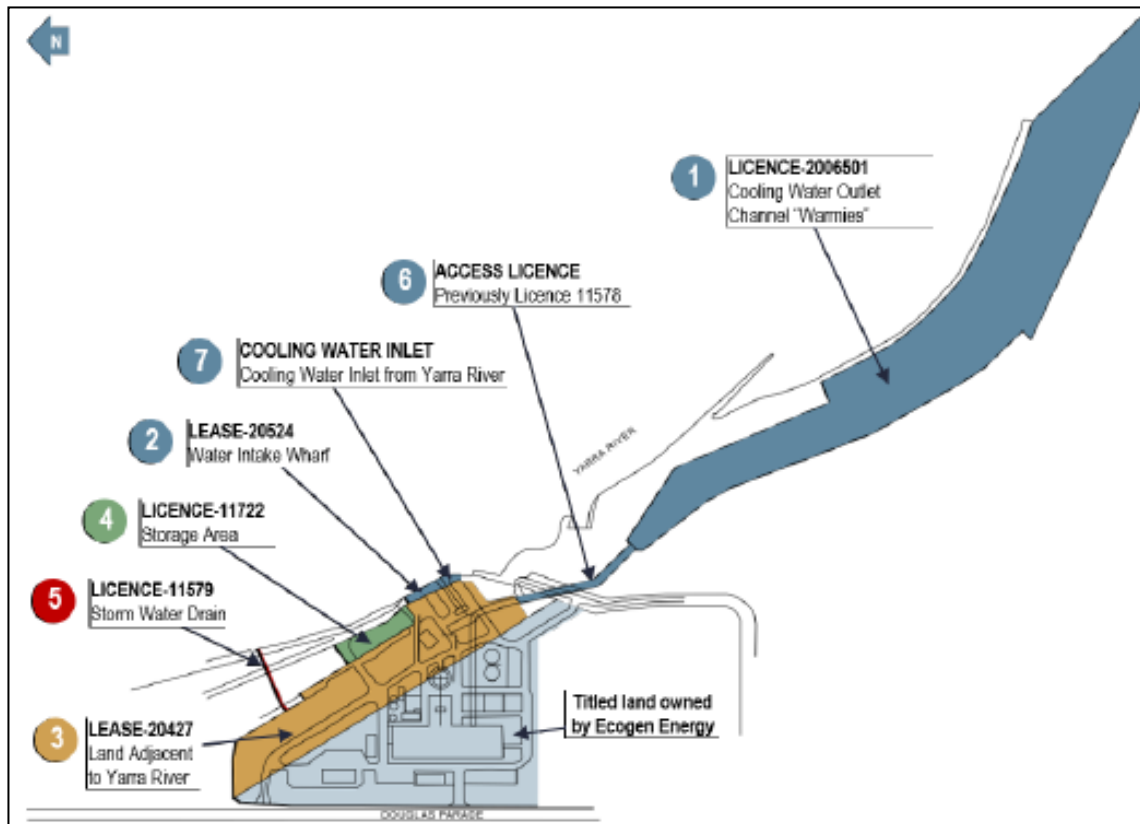

Potential Site

Potential Development Area at Newport Power Station



Potential Site

Potential Arrangement Of Heat Recovery + Storage Plant

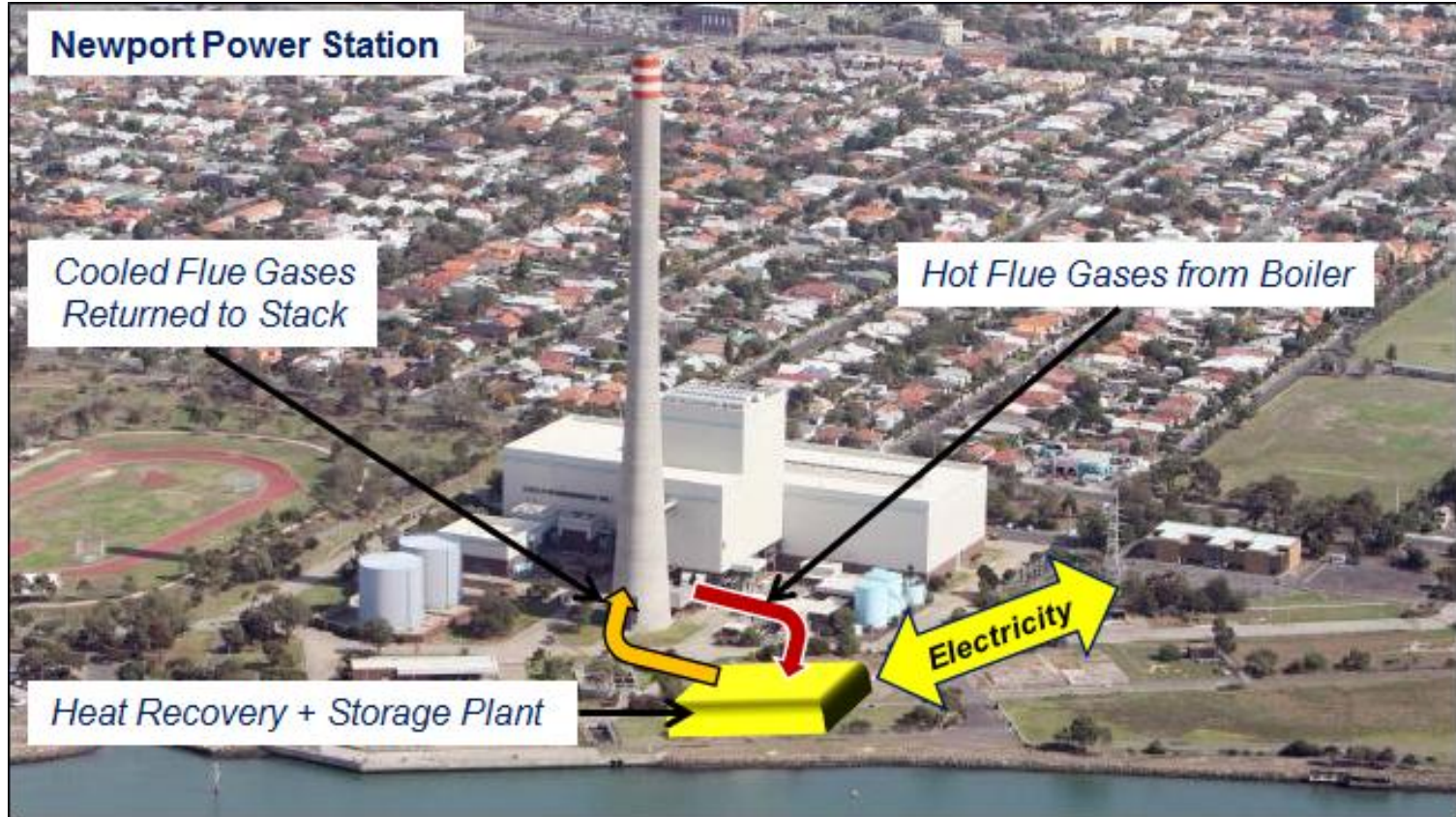

Efficiency Improvement Transformative Power Plant

Organic Rankin Cycle Turbine + Hydrogen Generation / Storage / Electricity Generation

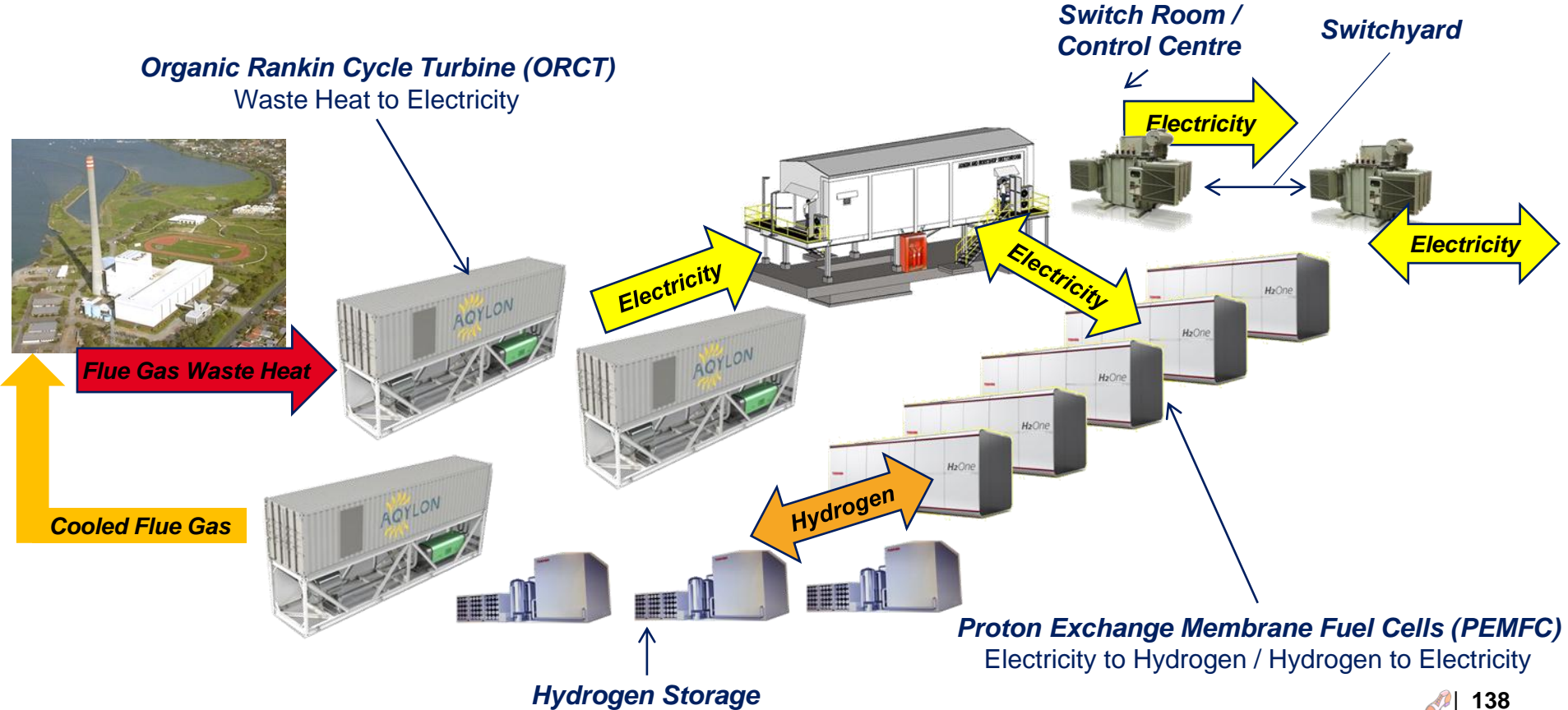

The Transformative Power Plant

Hydrogen Energy Storage

Why Consider Hydrogen Energy Storage

- Potential to for large scale Energy ($\text{Nm}^3 \text{H}_2$ to MWh_e) Storage only limited by Gas Storage infrastructure,
- Adaptable Power to Energy ratios ($\text{MW}_e - \text{MWh}_e$),
- Alternative uses for Hydrogen,
- Long term Storage capability with no degradation,
- Rapid response,
- Plant life potentially very long,



New Hydrogen storage technology based on cast Magnesium alloys with novel microstructure to store Hydrogen as a solid metal Hydride.



“The Transformative Power Plant” Technology Concept 4

Transformative Power
Plant As Applied To
Generating And Utilizing
Hydrogen + Firming
Renewables

Transformative Power Plant

Firming Renewables and Supporting the Hydrogen Economy

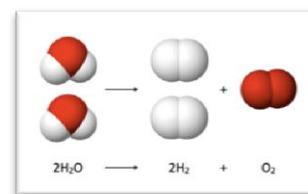

Water (H₂O) ↓ ↑ Oxygen (O₂)

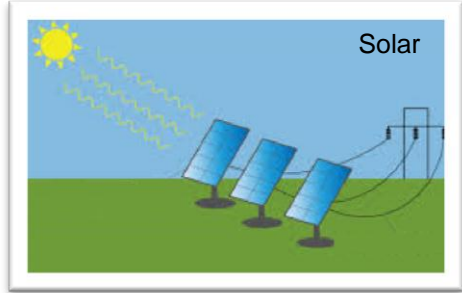

And / Or



Fuel Cells : Polymer Electrolyte Membrane (also know as Proton Exchange Membrane, PEM) Fuel Cells (PEMFC) utilising Hydrogen. PEMFCs currently are being trialled in a 2 MW block.

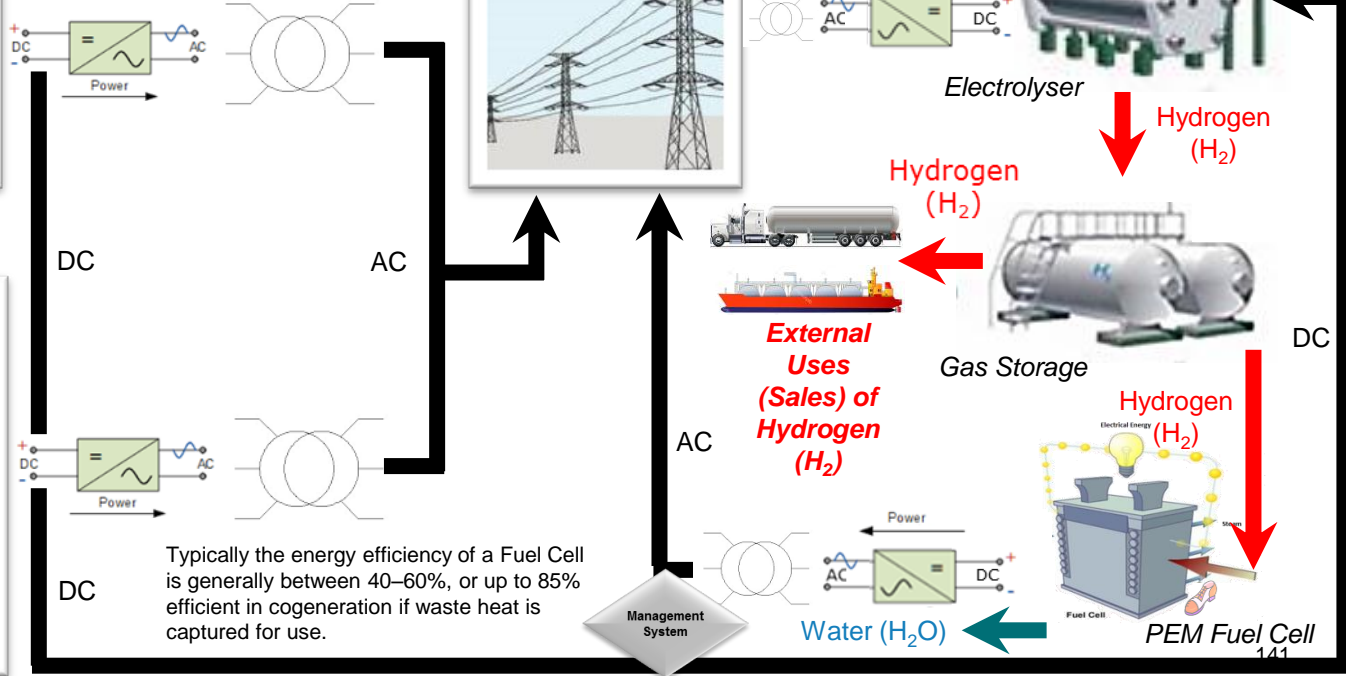

Typically the energy efficiency of a Fuel Cell is generally between 40–60%, or up to 85% efficient in cogeneration if waste heat is captured for use.

Transformative Power Plant

Firming Renewables and Supporting the Hydrogen Economy

The first 2 MW PEMFC now in operation in China (manufactured in Europe).

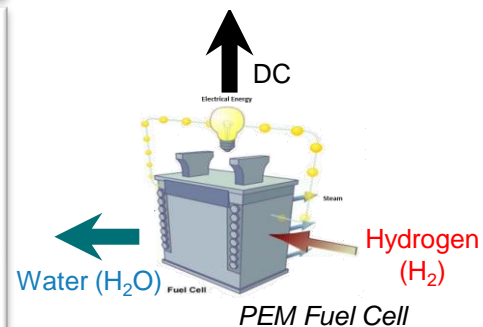
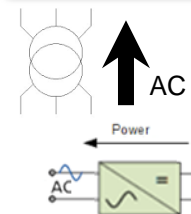
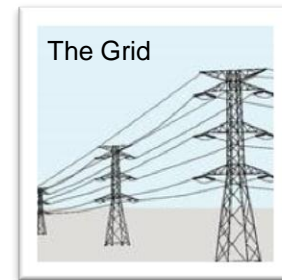
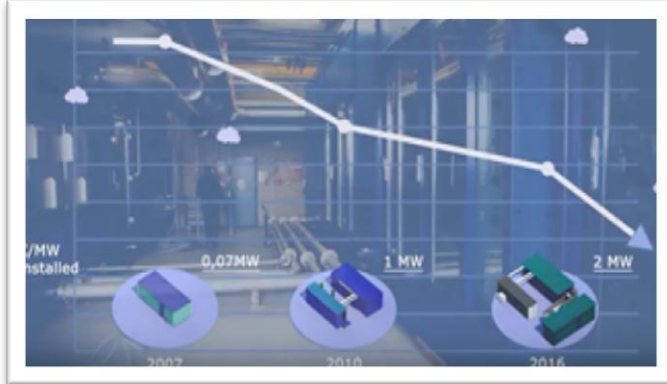

Transformative Power Plant

Firming Renewables and Supporting the Hydrogen Economy

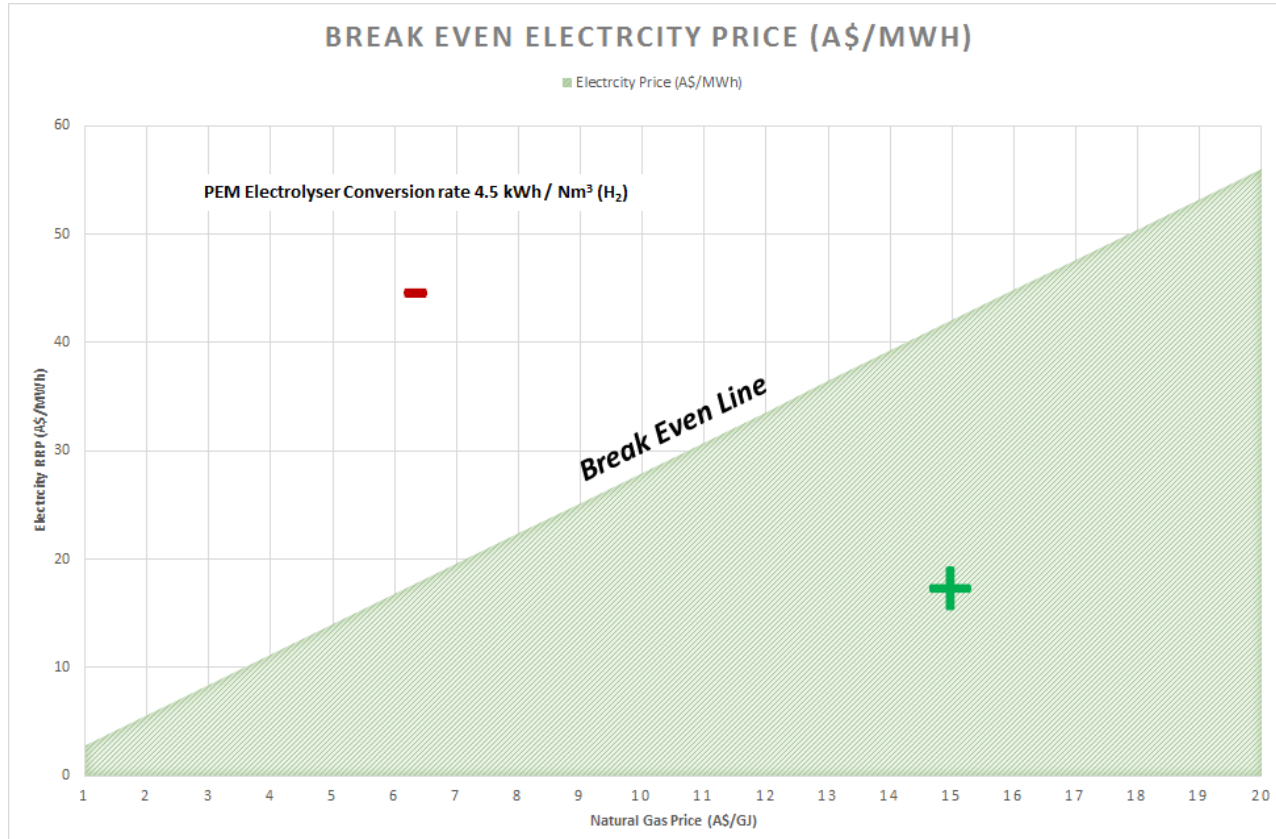

“The Transformative Power Plant” Technology Concept 5

Transformative Power
Plant As Applied To Black
Coal Gasification +
Hydrogen Economy

Transformative Power Plant

Black Coal and the Hydrogen Economy

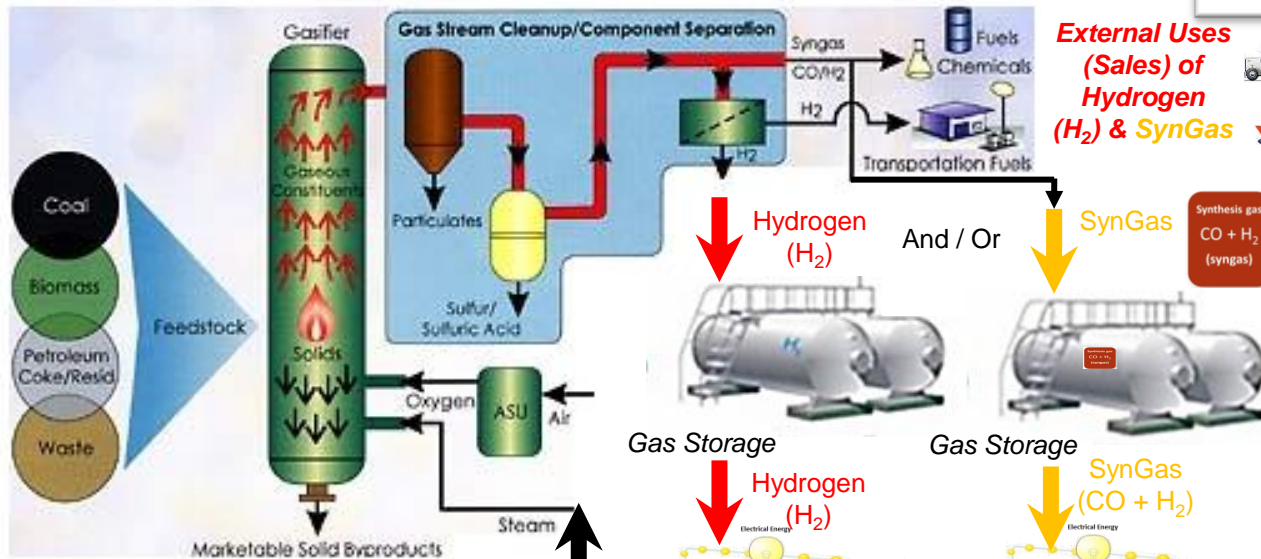
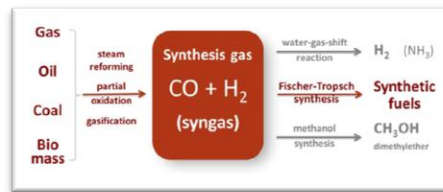

The Hydrogen Economy

Note : With the Gasification / Fuel Cell approach pure CO₂ is a by-product which is produced without further Capture needed. In addition, the Fuel cell approach offers very high Efficiencies(≈ 60% +) therefore the Greenhouse Gas Intensity (tCO₂e / MWh) would be much lower.

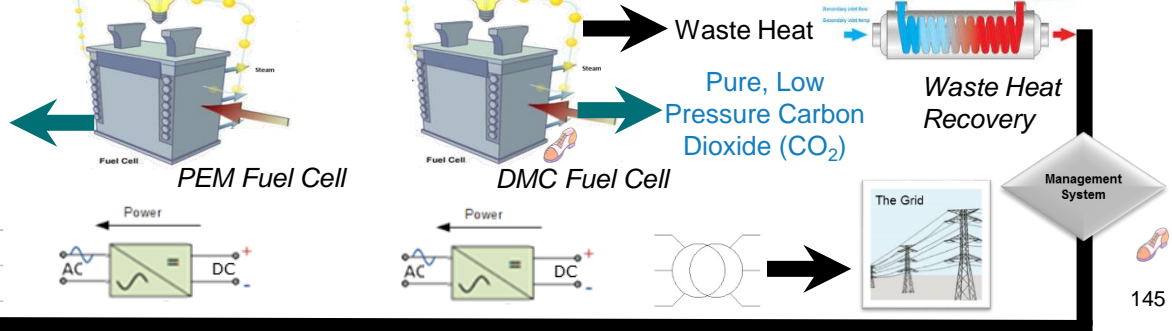

The Transformative Power Plant – Flexibility + Opportunity

Outputs :

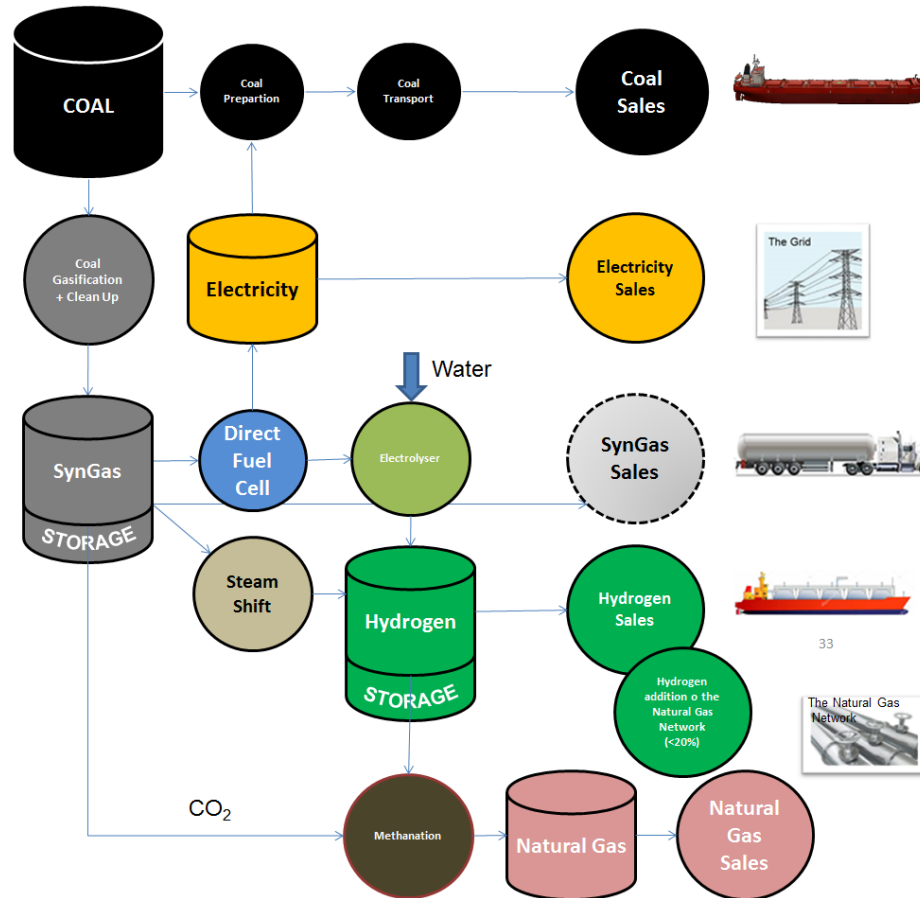

Coal

Electricity

SynGas

Hydrogen

Synthetic Natural Gas(SNG)

The Transformative Power Plant – Flexibility + Opportunity

Outputs :

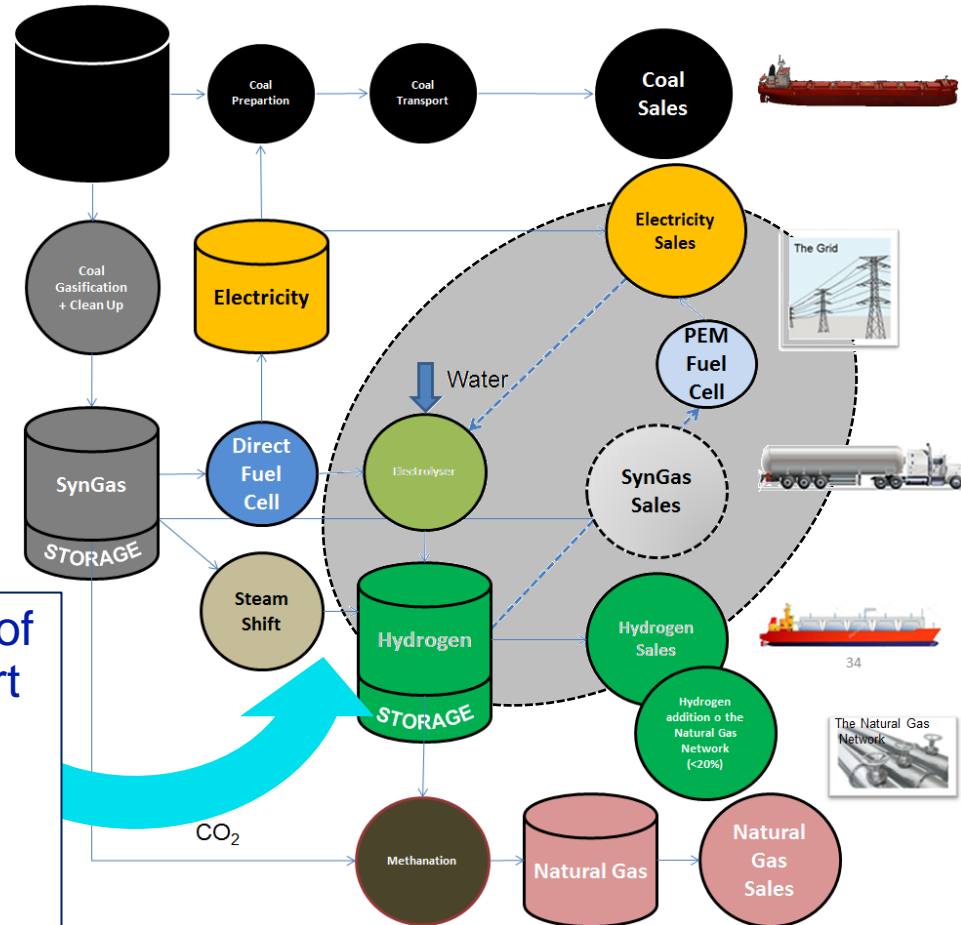

Coal

Electricity

SynGas

Hydrogen

Synthetic Natural Gas (SNG)

Added advantage of an ability to support Electricity Network and “Firm” Renewable Generation

“The Transformative Power Plant” Technology Concept 6

Adaptive Power Plant as
Firming South Australian
Renewables + Hydrogen
Economy

Transformative Power Plant

Firming Renewables and Supporting the Hydrogen Economy In South Australia

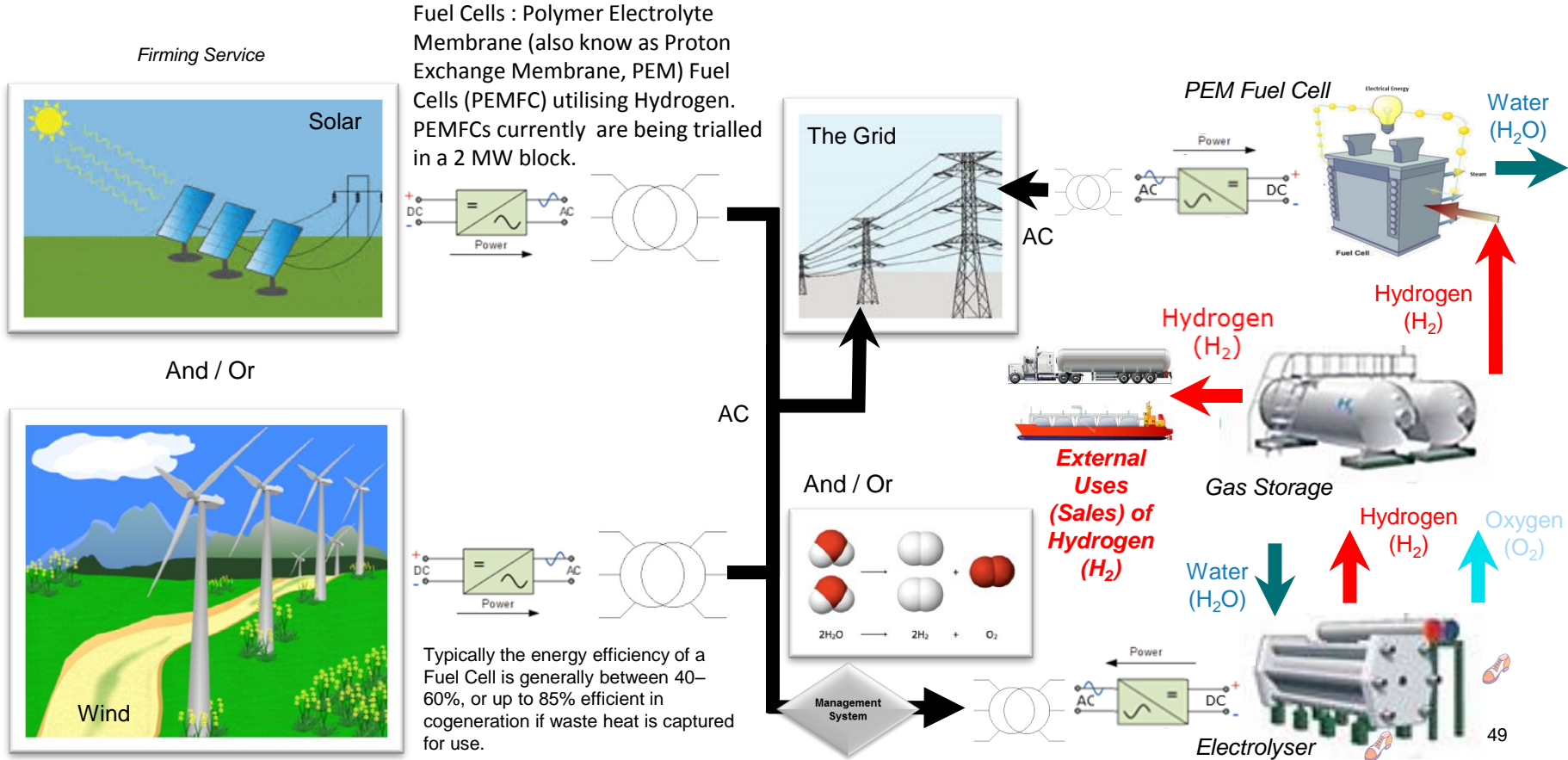

Transformative Power Plant

Firming Renewables and Supporting the Hydrogen Economy In South Australia

Transformative H₂ Port Augusta Plant

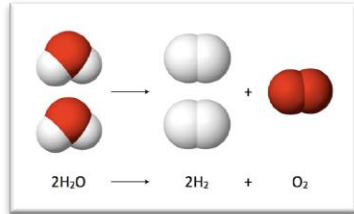

Hydrogen Production (Electrolysis)



Gas (Energy) Storage

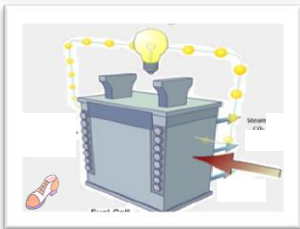

Generation (PEM Fuel Cells)

Potential for the development of a new “product” – Renewables Firming

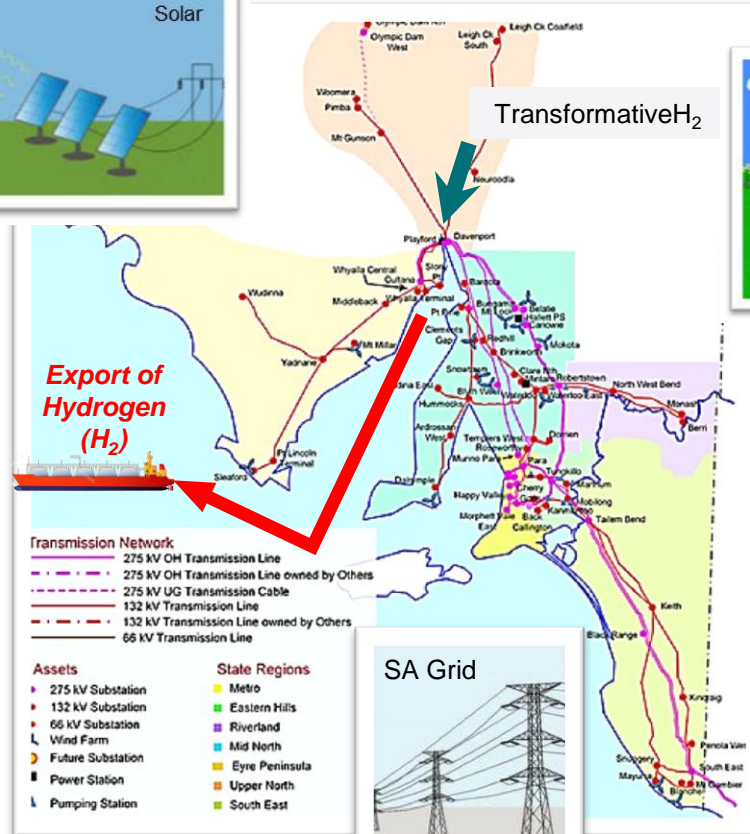
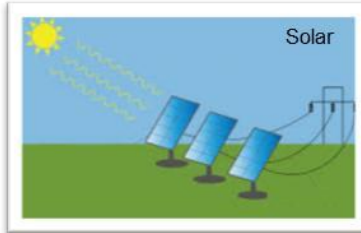

- Key point in the SA Electricity Grid,
- Key Load Centres to the north and south,
- Potential for high Solar based Generation,
- Existing high penetration of Wind Generation nearby,
- Possible location of H₂ export facility,
- Land available,
- Development needed.

Transformative Power Plant

Firming Renewables and Supporting the Hydrogen Economy In South Australia

Transformative H₂ Port Augusta Plant

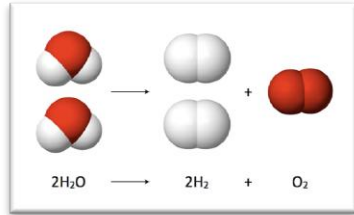

Hydrogen Production
(Electrolysis)



Gas (Energy) Storage

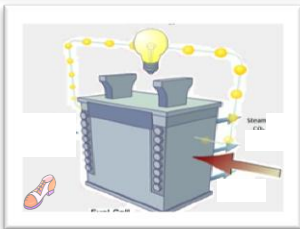

Generation
(PEM Fuel Cells)

Potential for the development of a new “product” – Renewables Firming

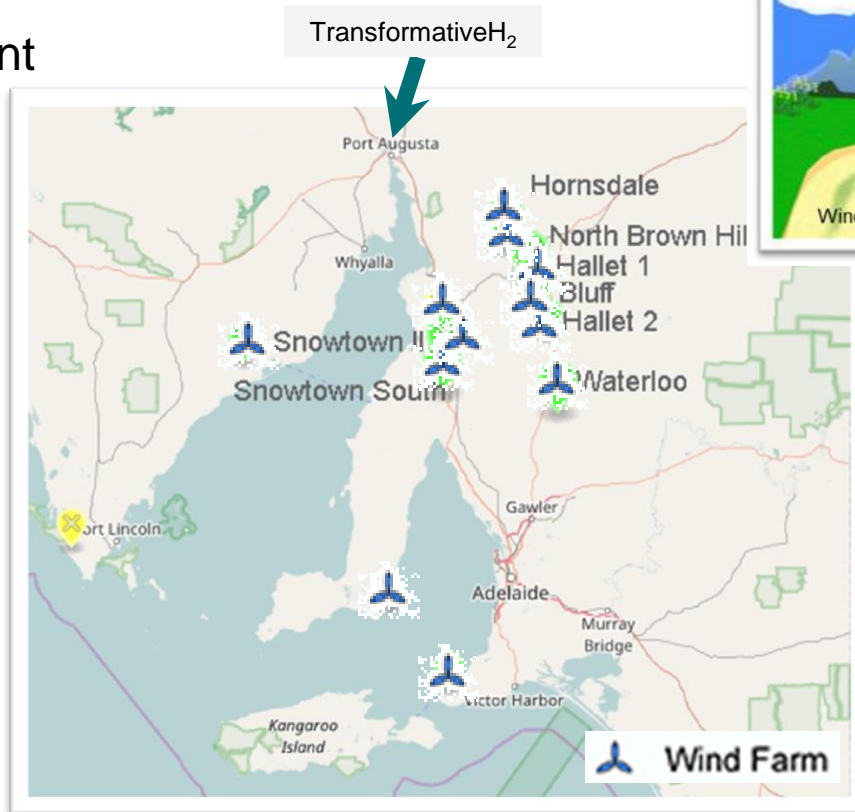

- Key point in the SA Electricity Grid,
- Key Load Centres to the north and south,
- Potential for high Solar based Generation,
- Existing high penetration of Wind Generation nearby,
- Possible location of H₂ export facility,
- Land available,
- Development needed.

“The Transformative Power Plant” Technology Concept 7

Transformative Power
Plant Supporting Large
Scale Consumers

Technology Concept 8 – Transformative Power Plant

Dependent on Fuel available, input could be :

- ✓ Natural Gas,
- ✓ SynGas,
- ✓ BioGas,
- ✓ Potentially Diesel,
- ✓ Hydrogen (PEM Fuel Cells)

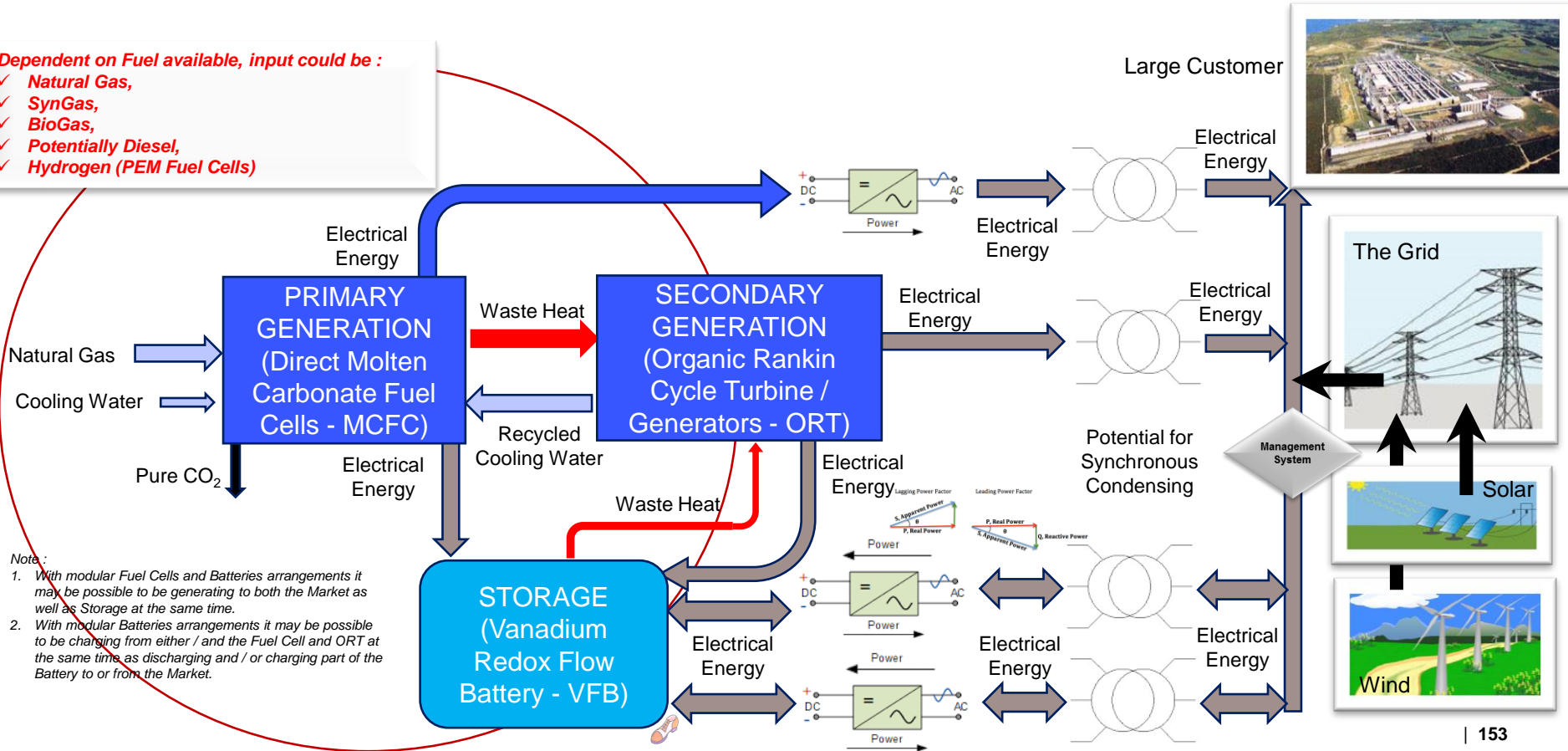

Note :

1. With modular Fuel Cells and Batteries arrangements it may be possible to be generating to both the Market as well as Storage at the same time.
2. With modular Batteries arrangements it may be possible to be charging from either / and the Fuel Cell and ORT at the same time as discharging and / or charging part of the Battery to or from the Market.

“The Transformative Power Plant” Technology Concept 8

Transformative Power
Plant Supporting Gas
Processing Plant
Efficiency

Technology Concept 9 – Transformative Power Plant

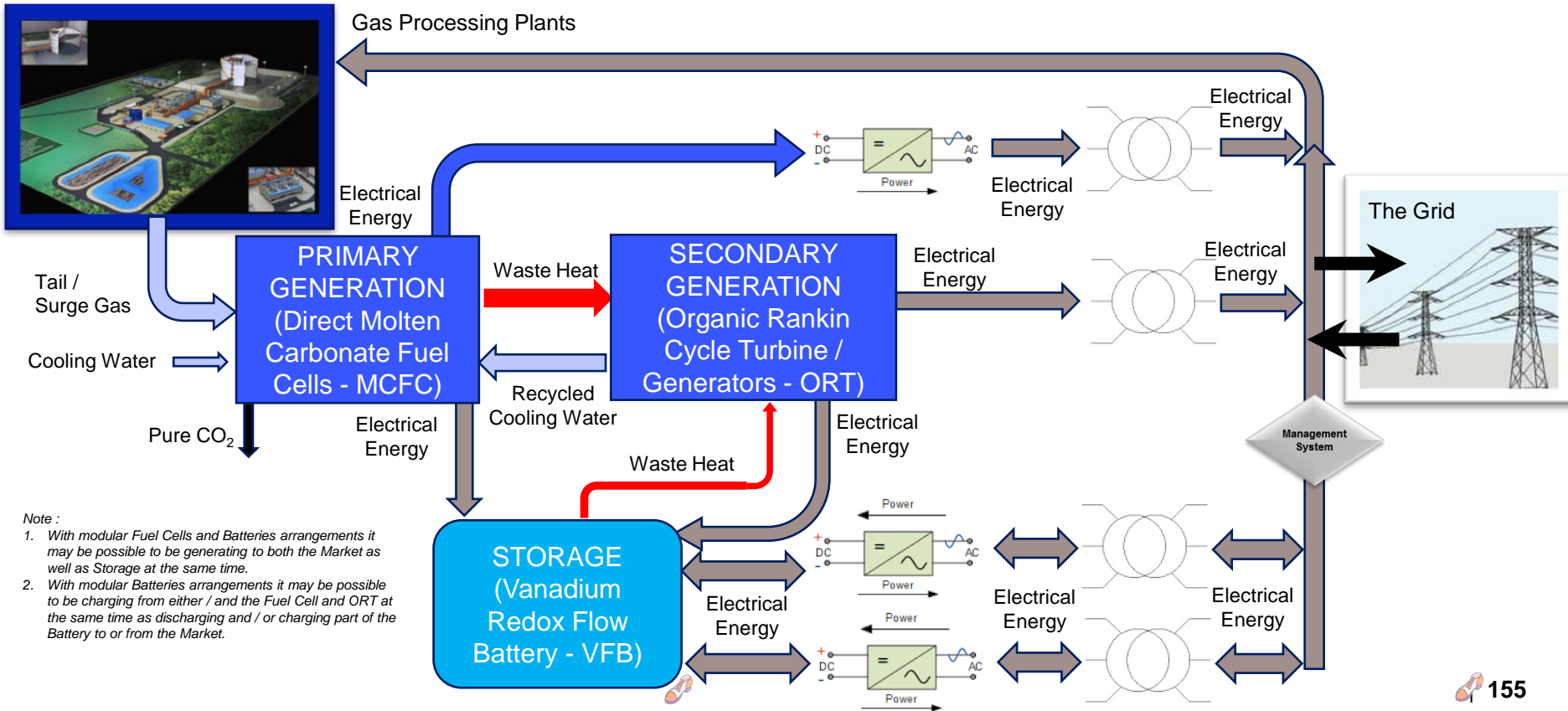

“The Transformative Power Plant” Technology Concept 9

Transformative Power
Plant Synthetic Natural
Gas and The Hydrogen
Economy

Trnasformative Power Plant

Firming Renewables, Supporting the Hydrogen Economy and Providing Synthetic Natural Gas

Fuel Cells : Polymer Electrolyte Membrane (also know as Proton Exchange Membrane, PEM) Fuel Cells (PEMFC) utilising Hydrogen. PEMFCs currently are being trialled in a 2 MW block.

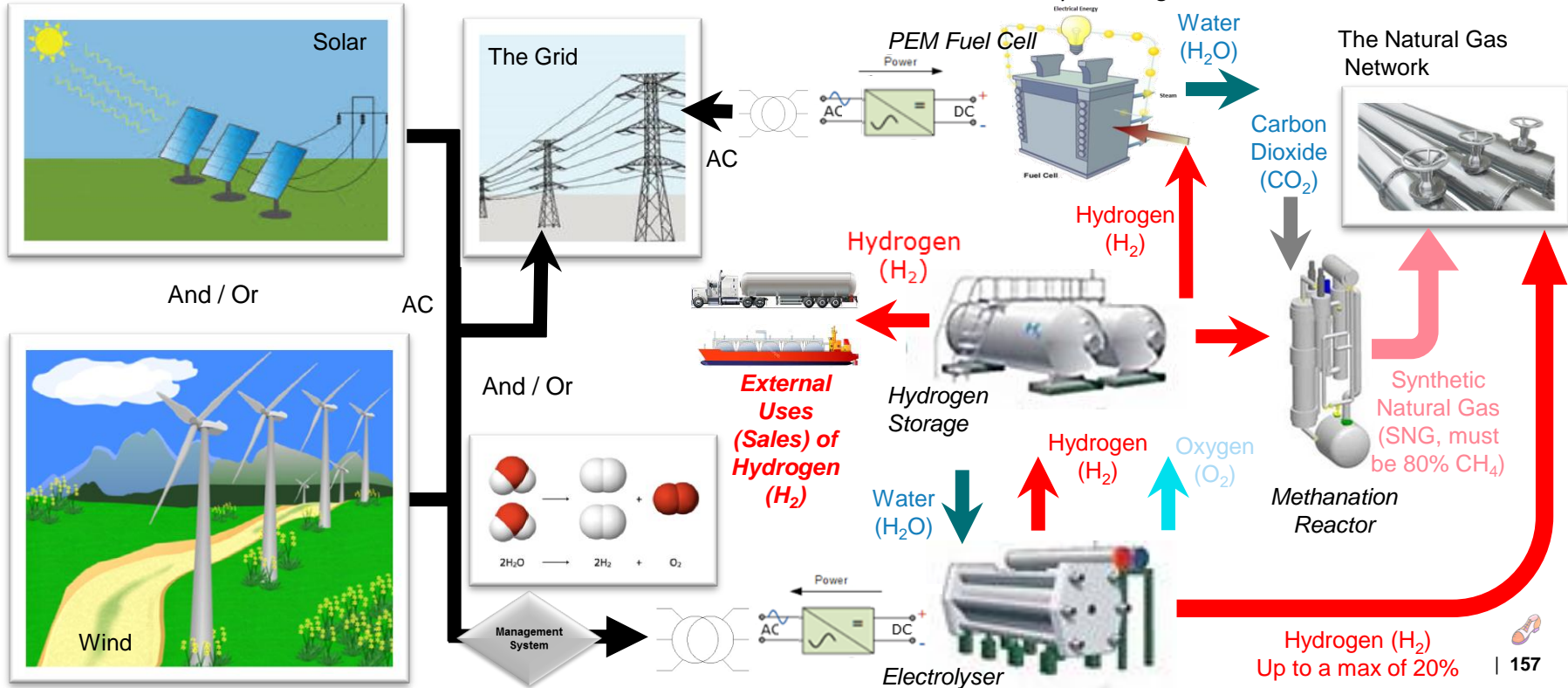

Transformative Power Plant

Firming Renewables, Supporting the Hydrogen Economy and Providing Synthetic Natural Gas

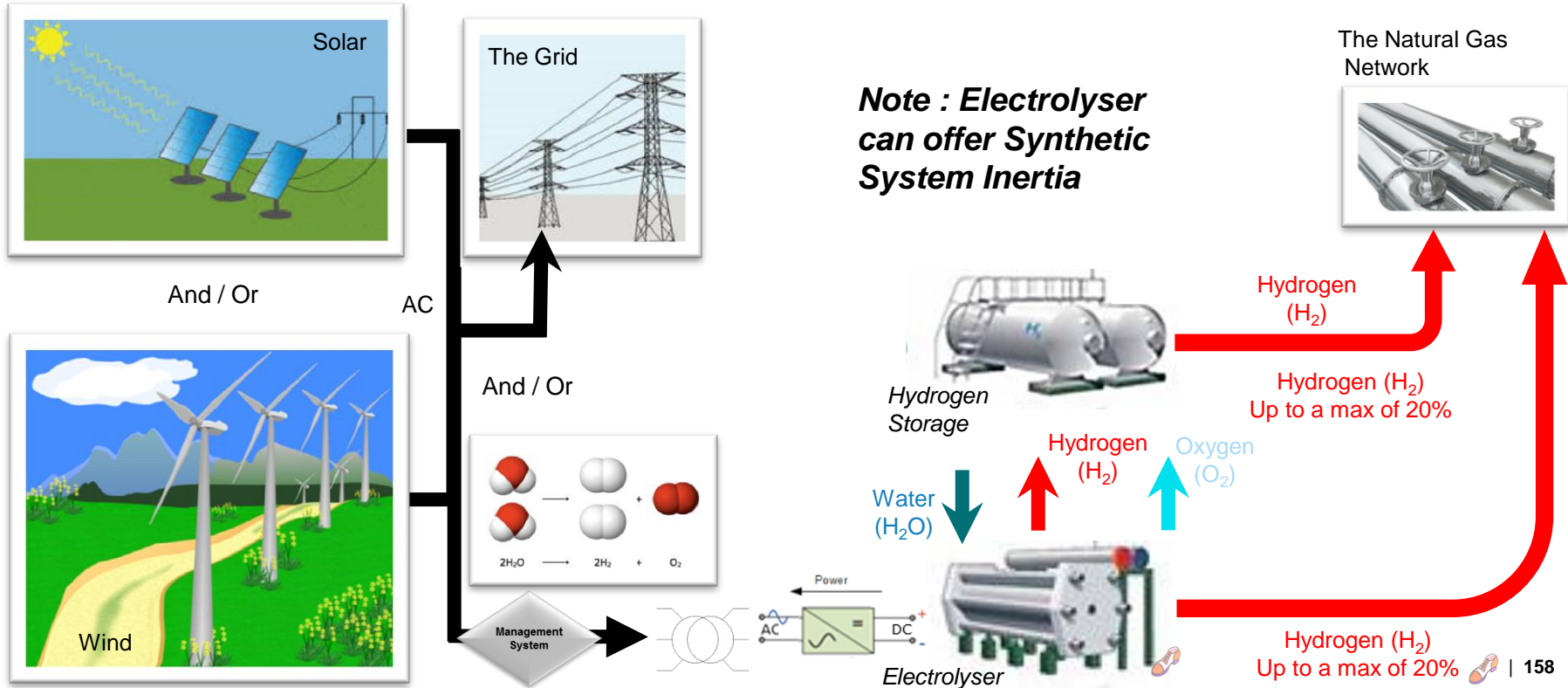

Transformative Power Plant

Coal Gasification, Supporting the Hydrogen Economy and Providing Synthetic Natural Gas

Fuel Cells (either Direct Molten Carbonate Direct Fuel Cells (DMCFC) using SynGas and / or Polymer Electrolyte Membrane (PEM sometimes refer to as Proton Exchange Membrane) Fuel Cells (PEMFC) utilising Hydrogen). MCDFCs are commercially available in blocks up to approximately 3.9 MW per block and PEMFCs are being trialled in a 2 MW block currently.

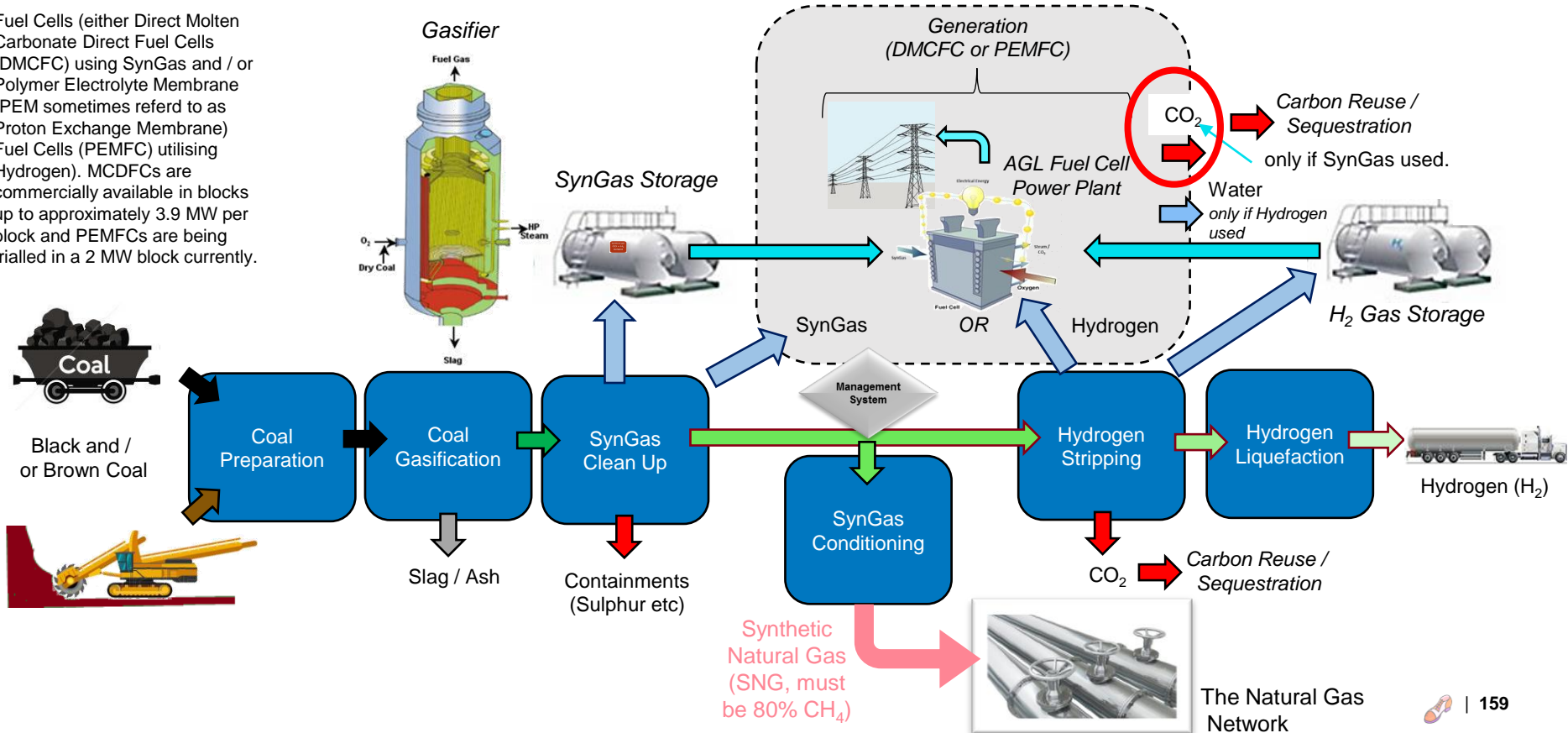

POSCO Gwangyang Project for Substitute Natural Gas (SNG)

- 0.7 B NM³/yr SNG production (500,000 mtpy)
- 5500 mtpd sub-bituminous coal processed into syngas and catalytically converted to methane
- 2 + 1 Gasification Trains
- Located adjacent to the POSCO Gwangyang Steel Mill on reclaimed land
- Groundbreaking 2Q2011, Start-Up in 4Q2014
- First Gasifier set April 2013

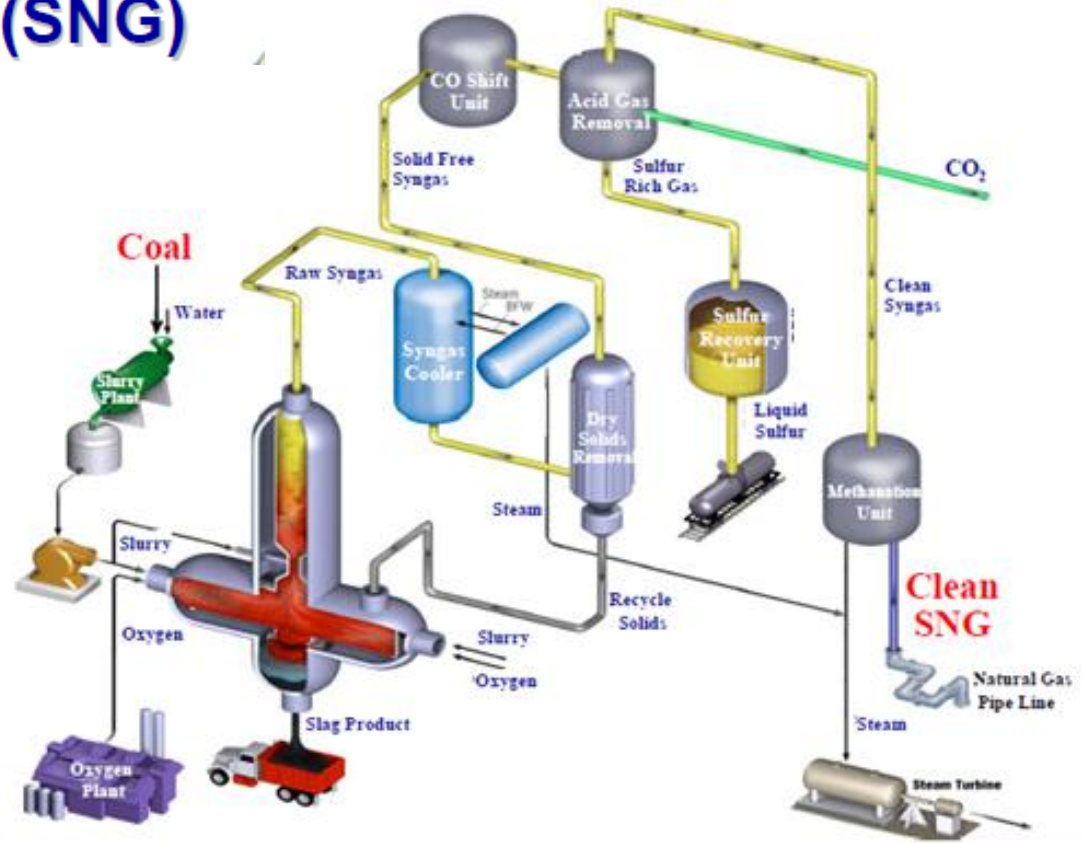

POSCO Gwangyang Project for Substitute Natural Gas (SNG)

Location : POSCO Gwangyang Steel Works, South Korea



Artist's Concept



posco

500,000 mtpy SNG
2+1 trains
sub-bituminous coal

Site Photo
Sept. 30, 2013

Construction Photograph 30th September, 2013

POSCO Gwangyang Project for Substitute Natural Gas (SNG)

- Feedstock Capacity & Specification : 5,500 mtpd (1.8 MM mTPY) Sub-Bituminous Coal

Selected Coals			Feedstock Range
Gross As Received (GAR)	Total Moisture (as received)	%	20-30
Air Dried Basis (ADB)	Intrinsic Moisture	%	18.0
	Volatile Matter	%	32.0-38.0
	Ash	%	3-6
	Fixed Carbon	%	39.0-41.0
	S	%	0.2-1.0
	Cl	%	0.01-0.03
Ultimate Analysis Dried Ash Free (daf)	HGI		40-42
	S.E. gar (HHV)	kcal/kg	5,150-5,350
	S.E. gad (HHV)	kcal/kg	5,500-5,735

POSCO Gwangyang Project for Substitute Natural Gas (SNG)



POSCO Gwangyang Steel Works Complex



Operating SNG Plant Today

“The Transformative Power Plant” Technology Concept 10

Adaptive Power Plant
Supporting A Large On
Site Mining Customer +
Hydrogen Economy

Transformative Power Plant Phase 1 : Powering the Washery

Black Coal and the Hydrogen Economy

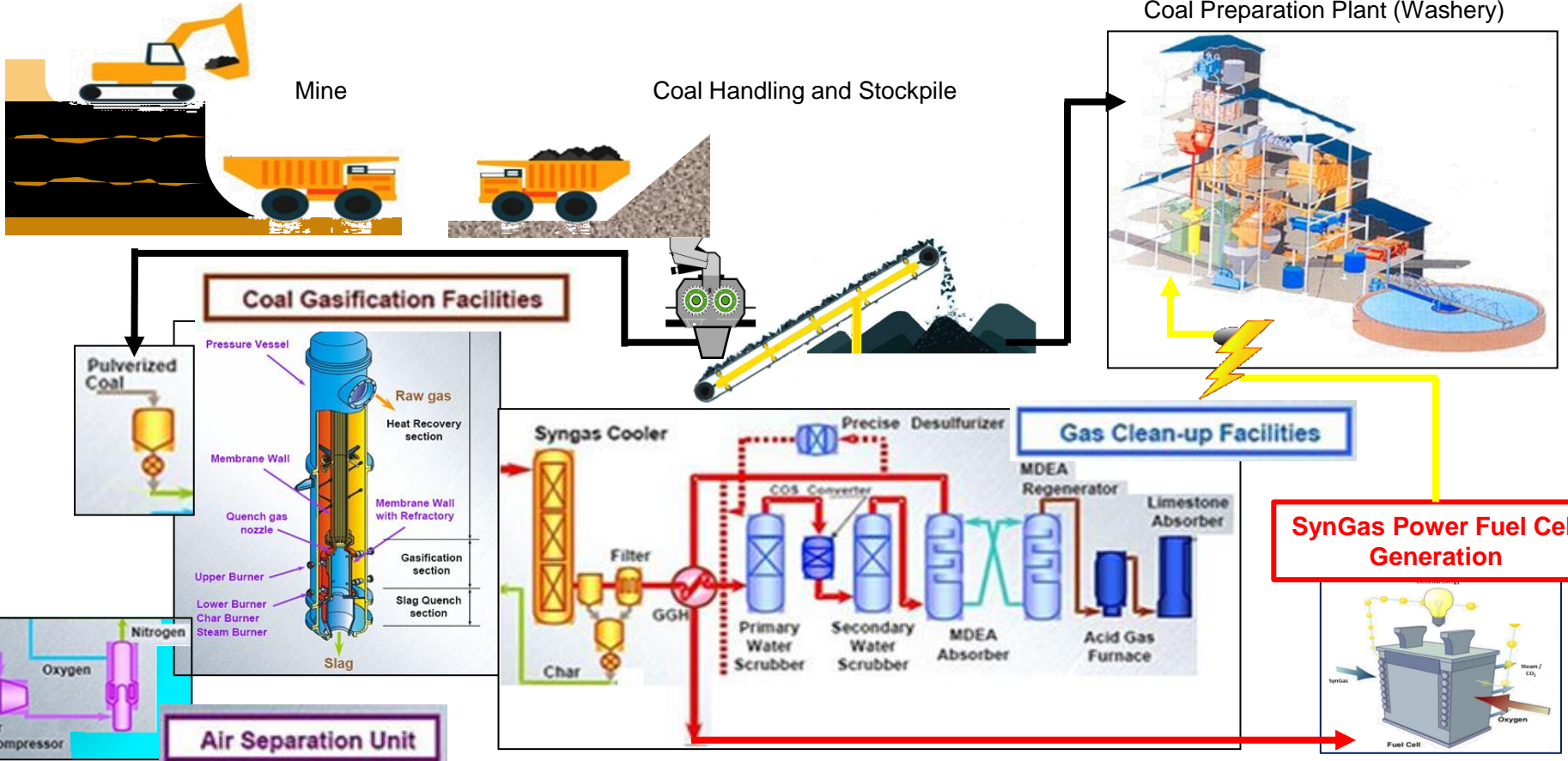

Transformative Power Plant Phase 2 : Adding Hydrogen Production

Black Coal and the Hydrogen Economy

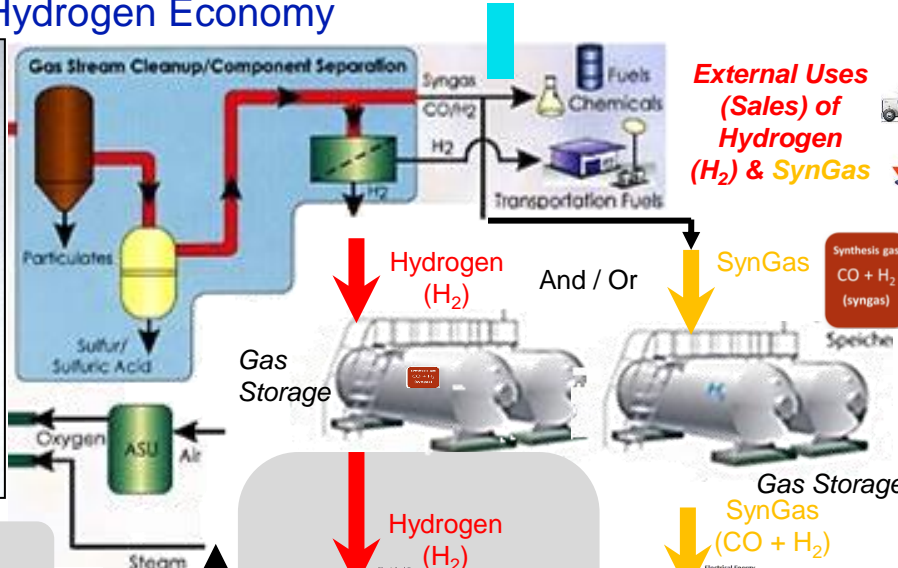
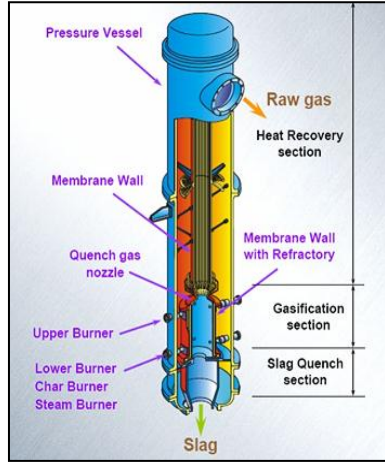

The Hydrogen Economy

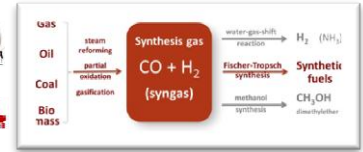

Note : With the Gasification / Fuel Cell approach pure CO₂ is a by-product which is produced without further Capture needed. In addition, the Fuel cell approach offers very high Efficiencies(≈ 60%+) therefore the Greenhouse Gas Intensity (tCO₂e / MWh) would be much lower.

Possible Phase 3 : Generation From Hydrogen

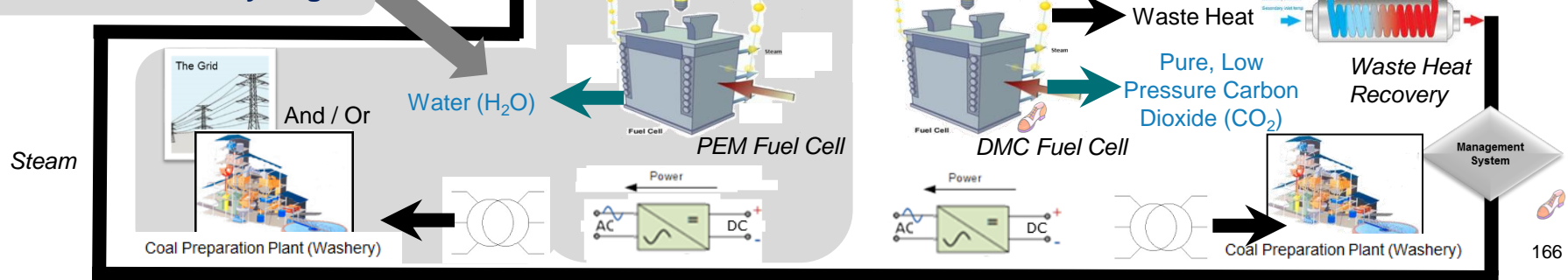



Background Information

Gasification

Coal – Gasification A Starting Place For Many Products

NOTE : This diagram represents Oxygen Blown Gasification from more “traditional” Gasifiers.

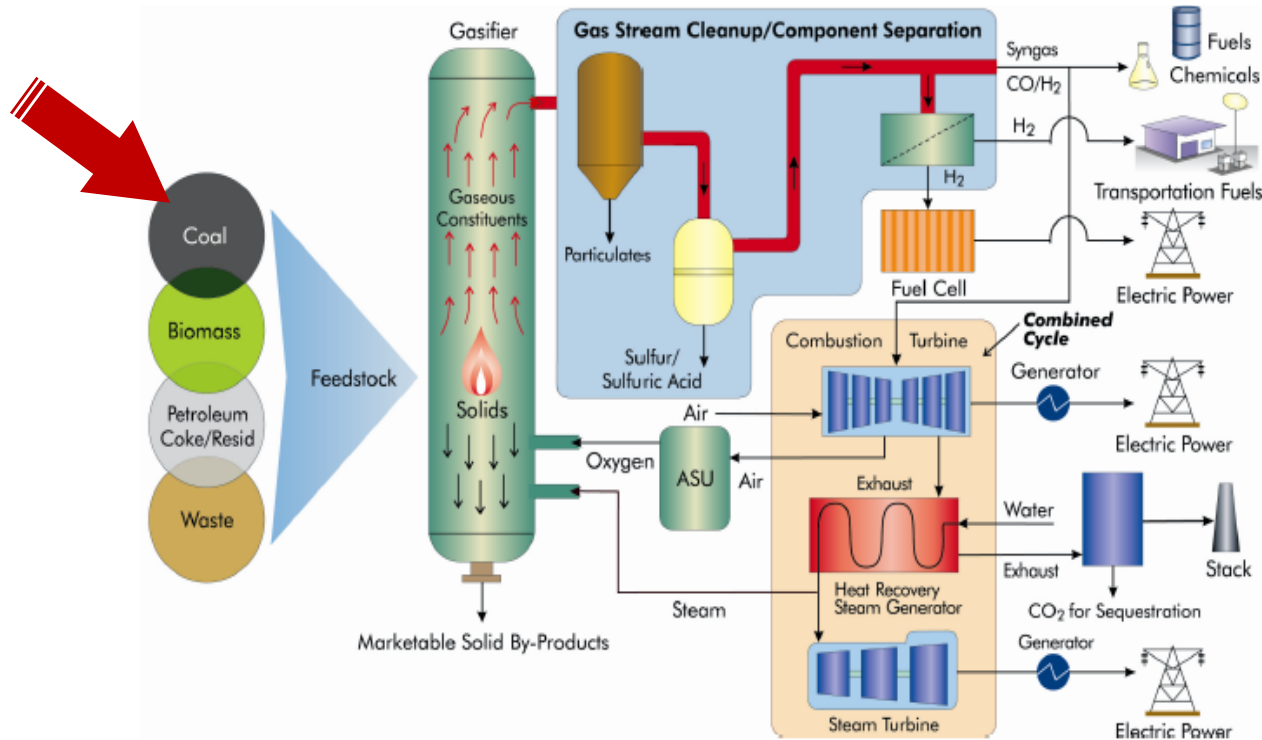

Source : Tennant, J. B., 2011, Gasification Technologies Program – Overview, National Energy Technology Laboratory (NETL), US Department of Energy, Washington DC.

Black Coal Gasification + Hydrogen

Fuel Cells (either Direct Molten Carbonate Direct Fuel Cells (DMCFC) using SynGas and / or Polymer Electrolyte Membrane (PEM sometimes refer to as Proton Exchange Membrane) Fuel Cells (PEMFC) utilising Hydrogen). MCDFCs are commercially available in blocks up to approximately 3.9 MW per block and PEMFCs are being trialled in a 2 MW block currently.

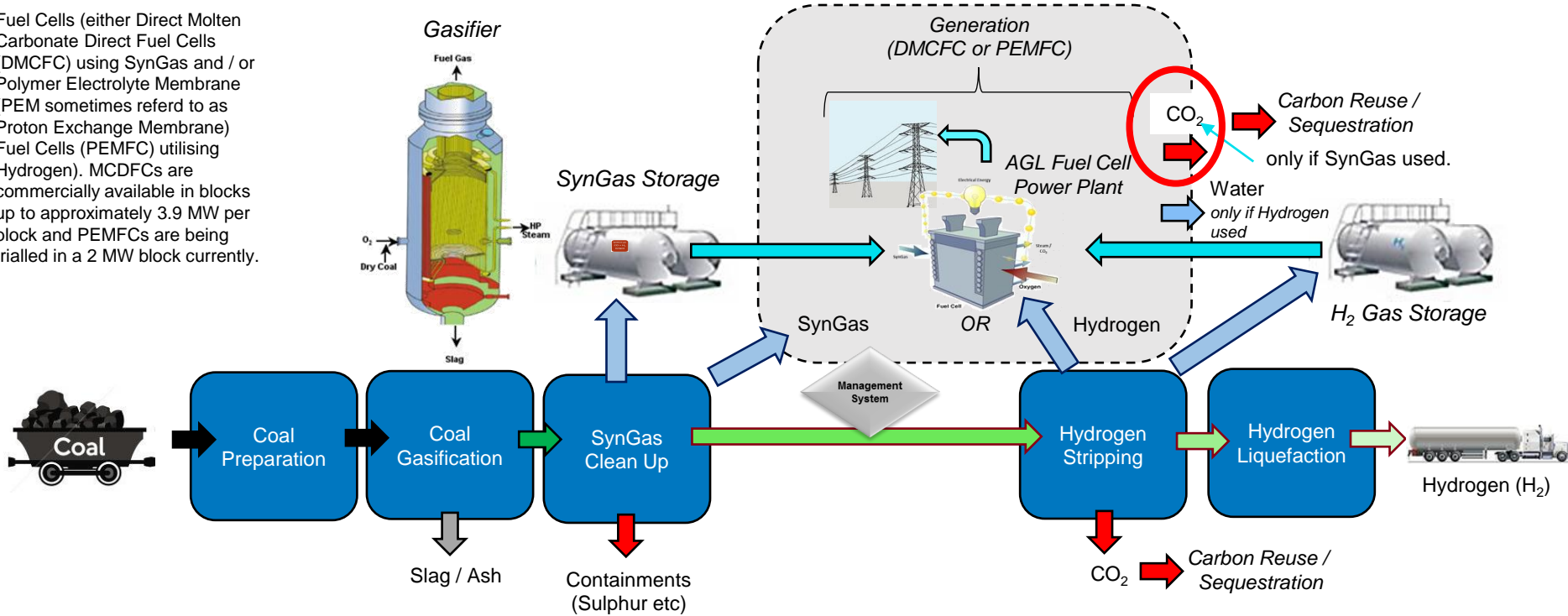

AGL High Efficiency Fuel Cell Concept

Fuel Cells (either Direct Molten Carbonate Direct Fuel Cells (DMCFC) using SynGas or Natural Gas and / or Polymer Electrolyte Membrane (PEM sometimes refer to as Proton Exchange Membrane) Fuel Cells (PEMFC) utilising Hydrogen). MCDFCs are commercially available in blocks up to approximately 3.9 MW per block and PEMFCs are being trialled in a 2 MW block currently.

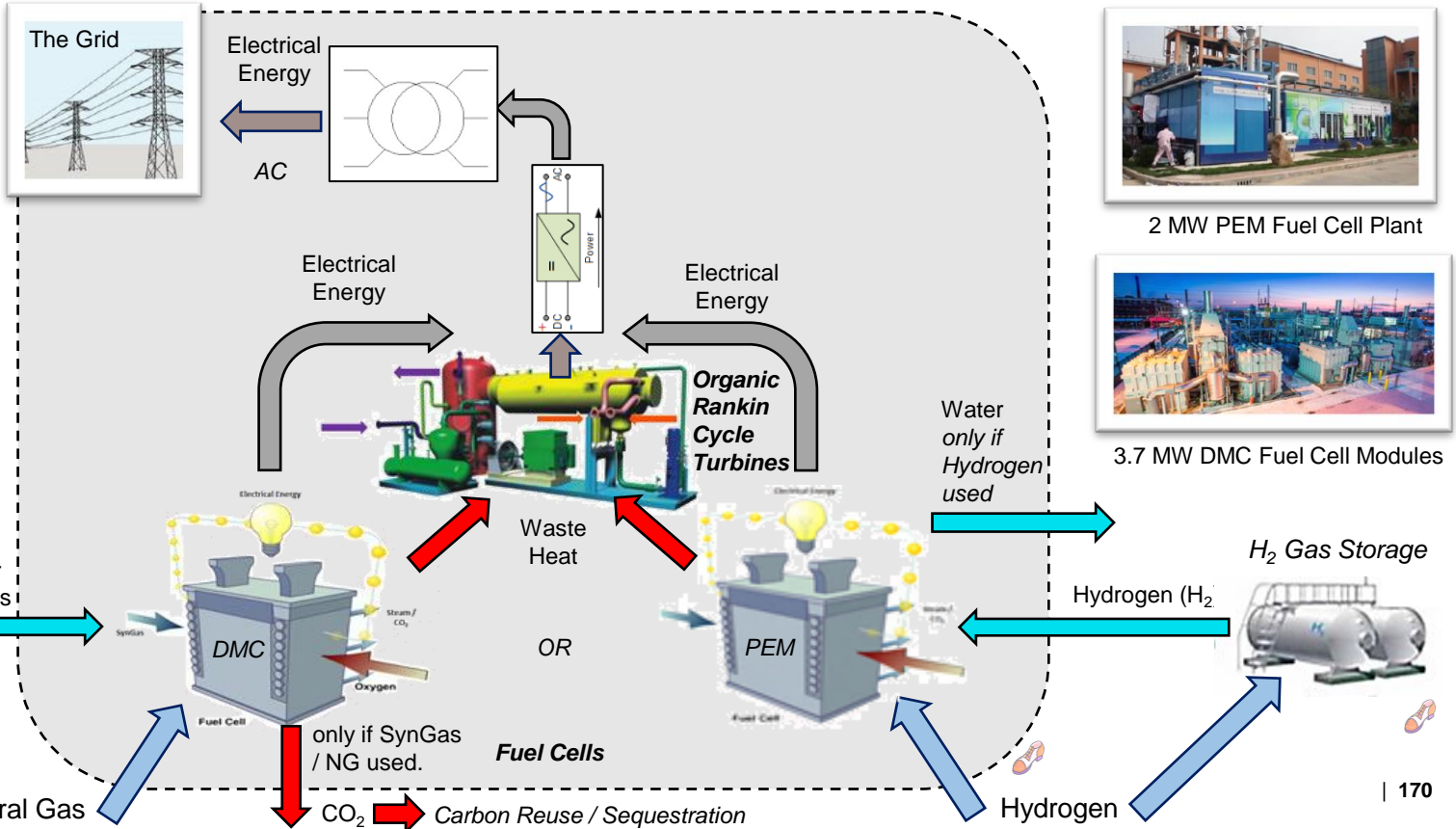

2 MW PEM Fuel Cell Plant



3.7 MW DMC Fuel Cell Modules

There Are Many Gasification Technologies

Types of Gasifiers

Although there are various types of Gasifiers (gasification reactors), different in design and operation characteristics, they are general classified into three categories:

- Fixed-bed Gasifiers (also referred as moving-bed Gasifiers)
- Entrained-flow Gasifiers
- Fluidized-bed Gasifiers

Commercial Gasifiers of GE Energy, ConocoPhillips E-Gas™ and Shell SCGP are examples of entrained-flow types. Fixed-or moving-bed Gasifiers include that of Lurgi and British Gas Lurgi (BGL). A number of other Gasifiers exist.

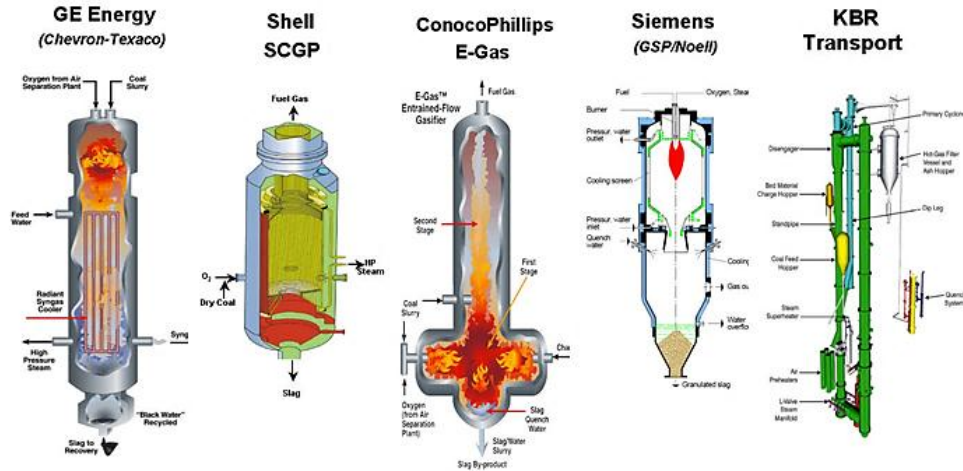

Source : Tennant, J. B., 2011, Gasification Technologies Program – Overview, National Energy Technology Laboratory (NETL), US Department of Energy, Washington DC.

There Are Many Gasification Technologies

Fixed-bed Gasifiers (also referred as moving-bed Gasifiers)

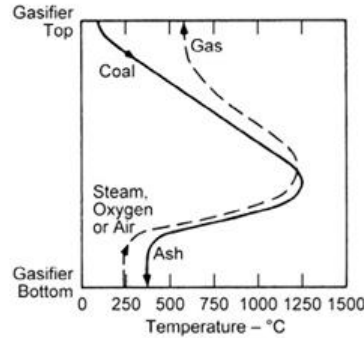
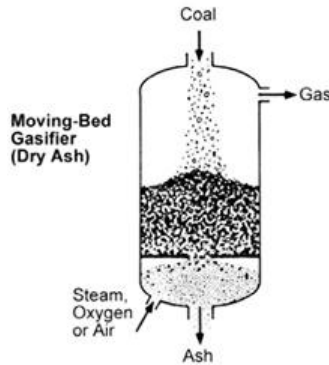

Entrained-flow Gasifiers

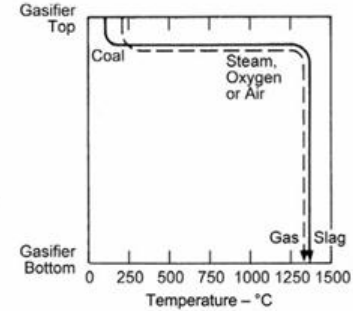
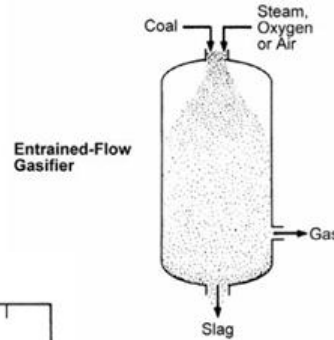

Fluidized-bed Gasifiers

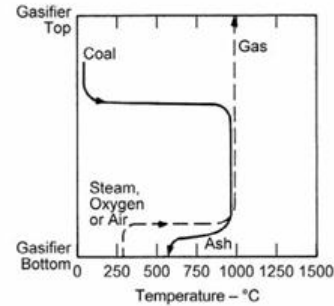
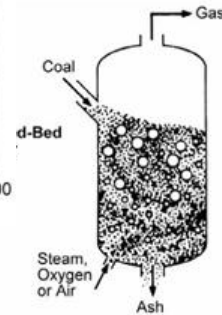

MHI Gasifier – An Example Of An Air Blown Gasifier

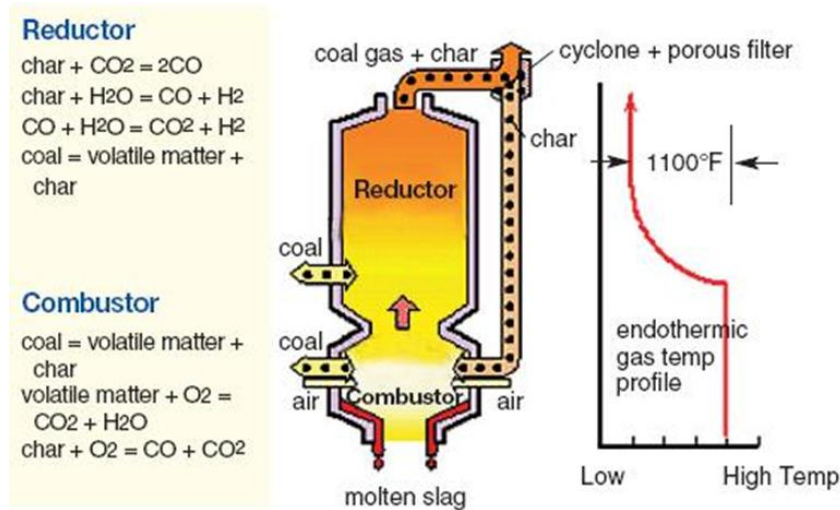

The Mitsubishi Heavy Industries (MHI) gasification technology was developed with the goal to maximize the gasifier efficiency (e.g., dry feed, and a unique two-stage reactor design) and reduce costs (e.g., air-blown to eliminate power consumption and capital cost of an oxygen plant).

The MHI gasifier is a pressurized, upflow, entrained-flow slagging reactor with a unique two-stage operation. The MHI gasifier, however, is a dry-feed system, and the reactor internal is protected by a membrane wall, similar to those of the Shell and Siemens designs. The current focus of the effort is on air-blown (or enriched air blown) IGCC application. R&D activities are being carried out to develop an oxygen-blown system for coal to fuels and chemicals applications.



Gasification – The Journey Is Well Underway

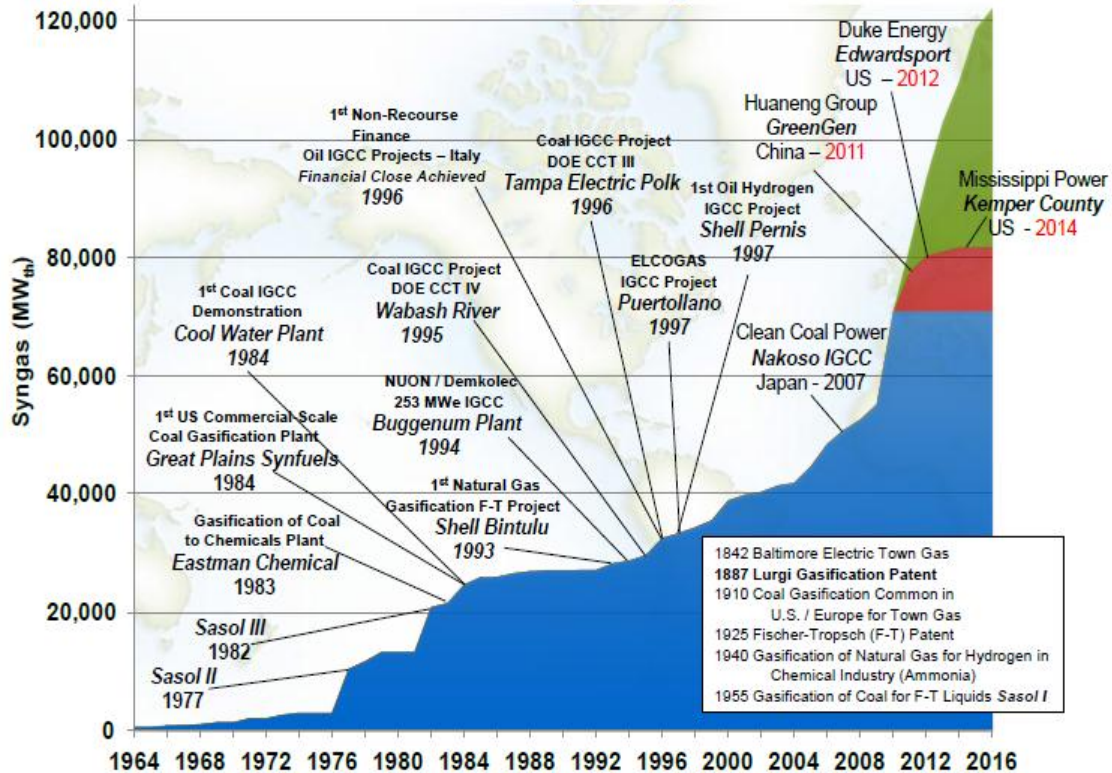

Source : NETL, 2010, Worldwide Gasification Database, National Energy Technology Laboratory (NETL), US Department of Energy, Washington DC.



Worldwide Gasification Capability & Planned Growth (by product)

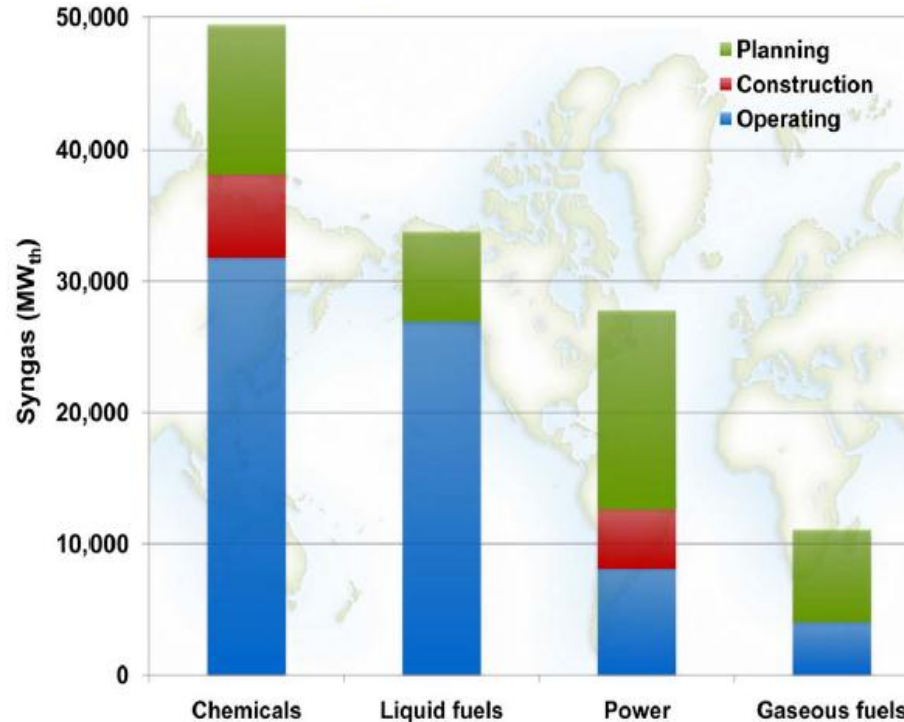

Source : NETL, 2010, Worldwide Gasification Database, National Energy Technology Laboratory (NETL), US Department of Energy, Washington DC.



Worldwide Gasification Capability & Planned Growth (by product)

<i>Feedstock</i>		<i>Operating 2010</i>	<i>Under Construction 2010</i>	<i>Planned 2011-2016</i>	<i>Totals</i>
Coal	Syngas Capacity (MW _{th})	36,315	10,857	28,376	75,548
	Gasifiers	201	17	58	276
	Plants	53	11	29	93
Petroleum	Syngas Capacity (MW _{th})	17,938			17,938
	Gasifiers	138			138
	Plants	56			56
Gas	Syngas Capacity (MW _{th})	15,281			15,281
	Gasifiers	59			59
	Plants	23			23
Petcoke	Syngas Capacity (MW _{th})	911		12,027	12,938
	Gasifiers	5		16	21
	Plants	3		6	9
Biomass/Waste	Syngas Capacity (MW _{th})	373		29	402
	Gasifiers	9		2	11
	Plants	9		2	11
Total Syngas Capacity (MW_{th})		70,817	10,857	40,432	122,106
Total Gasifiers		412	17	76	505
Total Plants		144	11	37	192

Source : NETL, 2010, Worldwide Gasification Database, National Energy Technology Laboratory (NETL), US Department of Energy, Washington DC.



Coal Gasification – Potentially Has A Lot To Offer

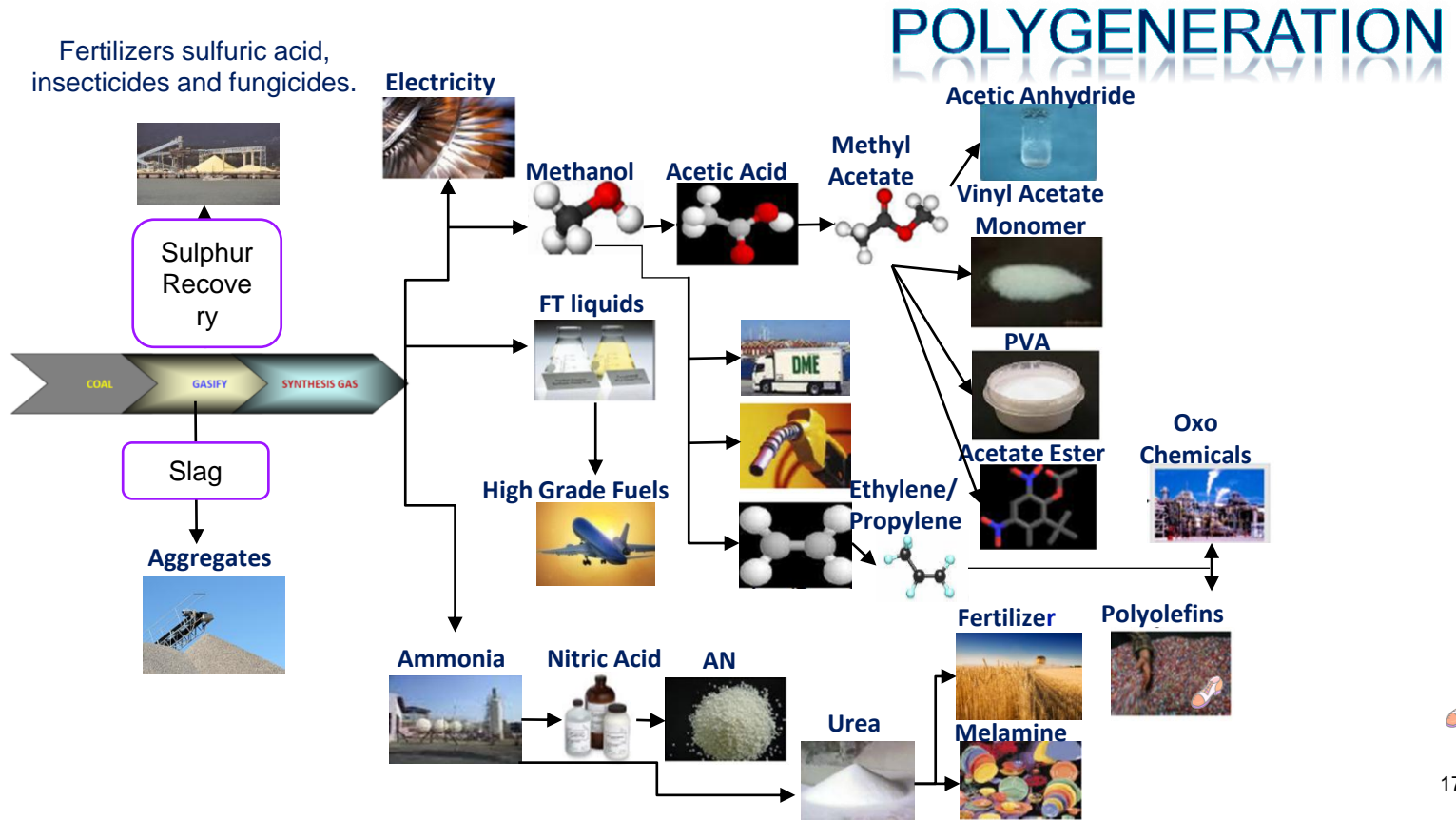

Coal Gasification – A Starting Place



Electricity



TECO Energy's IGCC
(Integrated Gasification,
Combined-Cycle)
Polk Power Station in
Polk County, Florida, USA.
The 260-megawatt IGCC
facility began commercial
operation in 1996.



Gasification – Polygeneration, Solutions To Other Issues

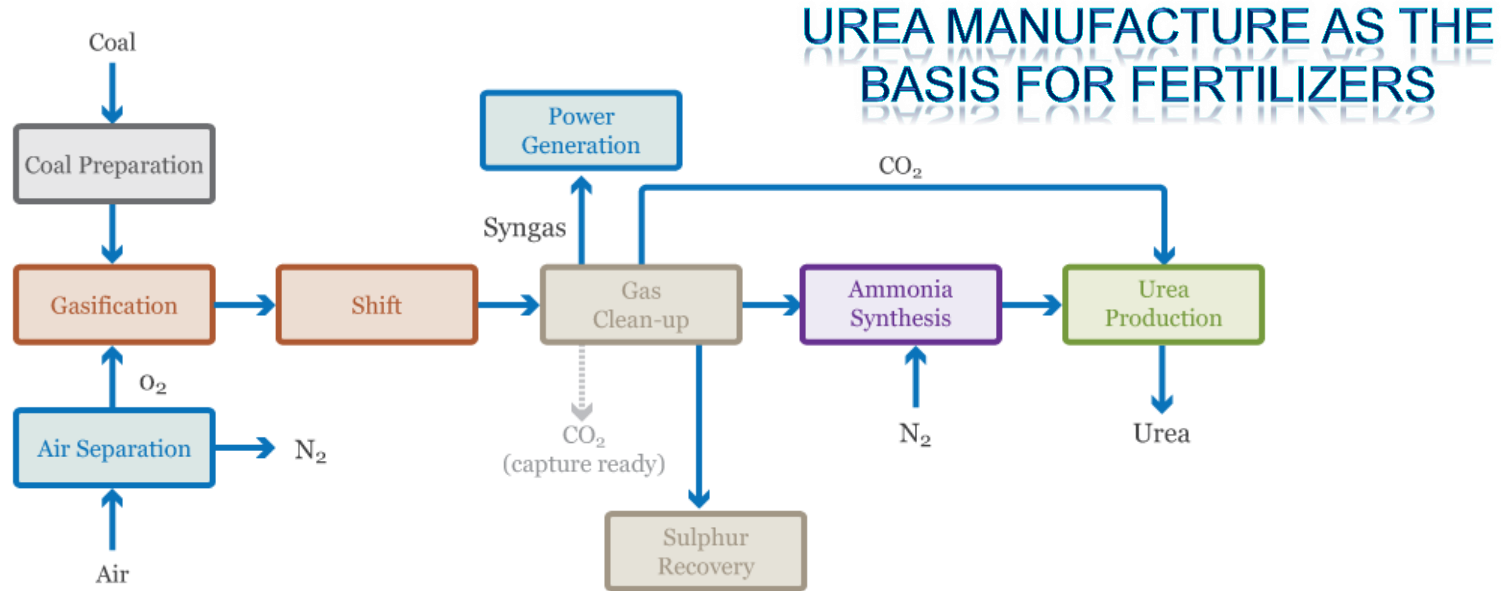

Urea Production

The ammonia is reacted with the carbon dioxide which was removed from the syngas in the gas clean-up section to produce liquid ureas. The urea solution is then dried and granulated, an easily transported and user friendly form of nitrogen



Transformative Power Plant – Polygeneration

Gasification – Polygeneration, Solutions To Other Issues

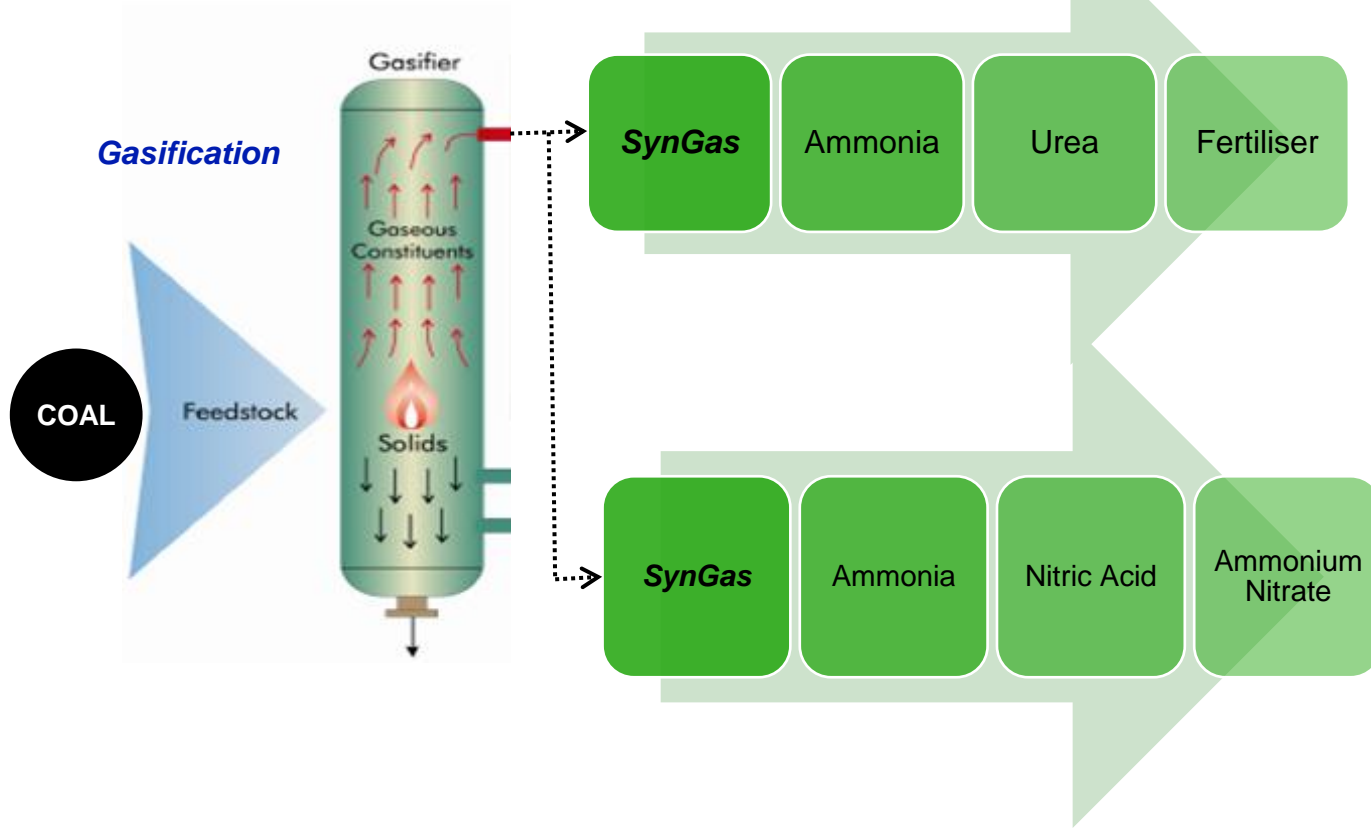

Transformative Power Plant

Black Coal and the Hydrogen Economy

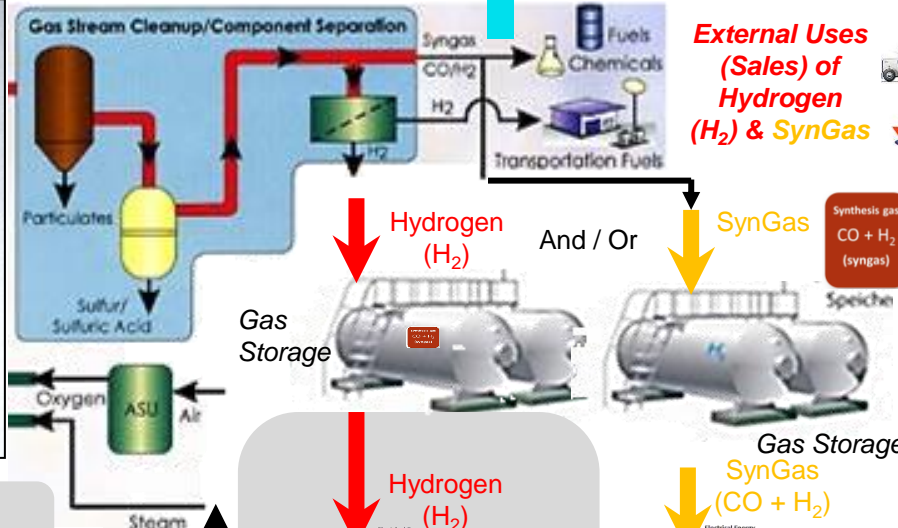
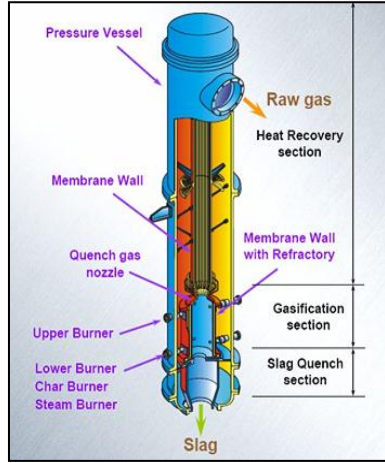

The Hydrogen Economy

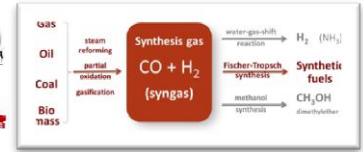

Note : With the Gasification / Fuel Cell approach pure CO₂ is a by-product which is produced without further Capture needed. In addition, the Fuel cell approach offers very high Efficiencies (≈ 60% +) therefore the Greenhouse Gas Intensity (tCO₂e / MWh) would be much lower.

Possible Phase 3 : Generation From Hydrogen

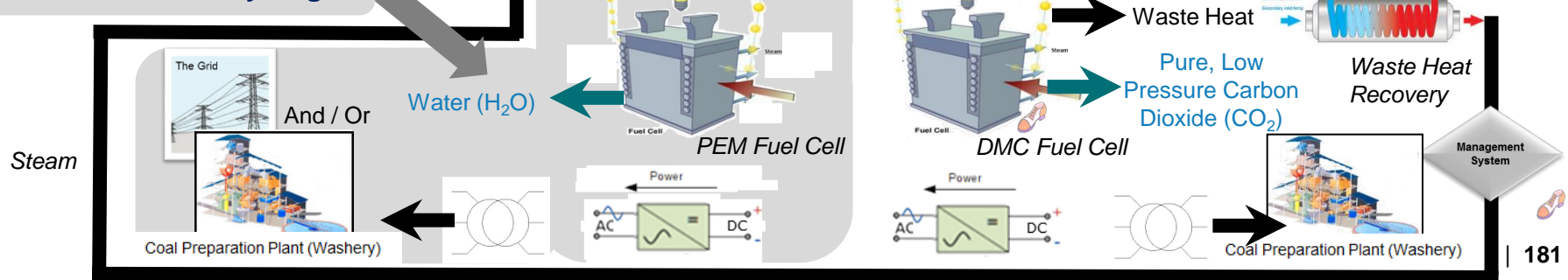

Transformative Power Plant – Polygeneration

Gasification – Polygeneration, Solutions To Other Issues

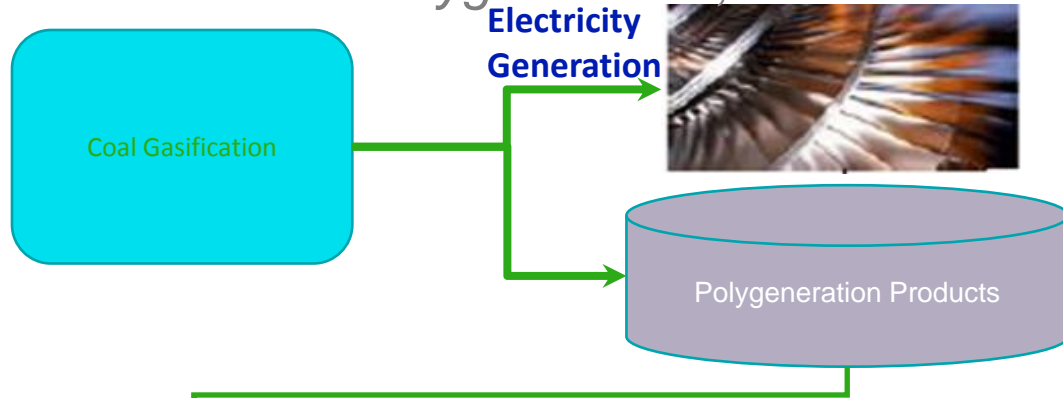
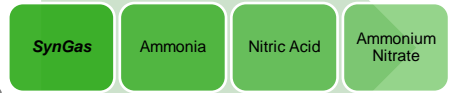

Note:
There are many Polygeneration products that can be produced from Syngas. However, the remote location of some coal deposits would make effective production of some products non commercial. One exception maybe the production of feedstock materials for explosive production. Such a scheme is illustrated here.



Ammonia

POLYGENERATION



Nitric Acid



Ammonium Nitrate



Ammonium Nitrate / Fuel Oil (ANFO)



Australian Demand For Explosives In The Mining Industry

Transformative Power Plant – Polygeneration

Gasification – Polygeneration, Solutions To Other Issues

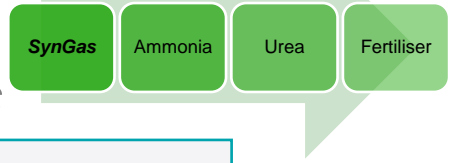

Note #1 : Teragrams (Tg), the usual measurement unit for discussing the global Nitrogen Cycle. Teragram is, a mixture of the metric prefix Tera (T) and the SI unit of weight gram (g), a unit of weight equal to 1E+9 kilogram or 1,000,000 tonne (metric tons).
 Reference : Heffer, P., & Prud'homme, M., 2016, "Global Nitrogen fertiliser demand and supply: trend, current level and outlook", International Fertilizer Association (IFA), Paris, France.

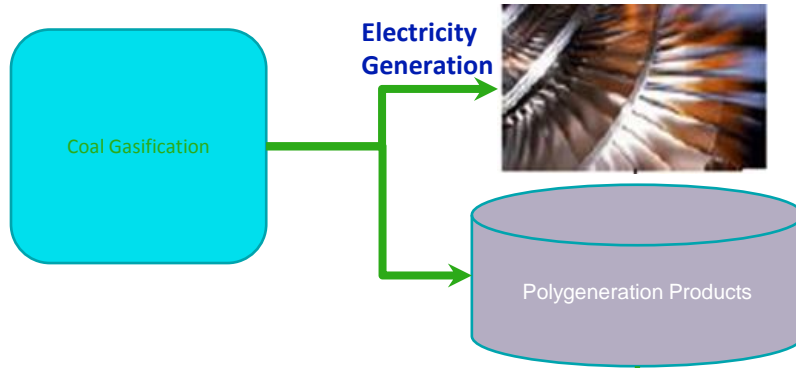

Note:
 There are many Polygeneration products that can be produced from Syngas. However, the remote location of some coal deposits would make effective production of some products non commercial. One exception maybe the production of feedstock materials for fertiliser production. Such a scheme is illustrated here.



Ammonia

POLYGENERATION

Evolution of regional Nitrogen fertilizer consumption by region (Tg N#1) (IFA, 2016a)



Urea



Fertiliser

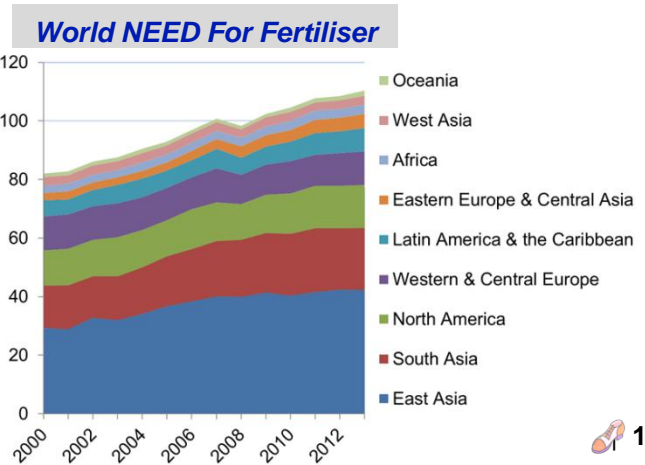

Transformative Power Plant – Polygeneration

The “Starting Point”

SynGas, or **Synthesis Gas**, is a fuel gas mixture consisting primarily of SynGas – a mixture consisting primarily of Carbon Monoxide (CO), Hydrogen (H₂), Carbon Dioxide (CO₂), Methane (CH₄), and water vapour (H₂O) – from coal and water, air and / or Oxygen (Air or Oxygen “blowen” Gasifier technology). The name comes from its use as intermediates in creating Synthetic Natural Gas (SNG) and for producing Ammonia or Methanol. SynGas is usually a product of gasification and the main application is electricity generation. SynGas is combustible and often used as a fuel of internal combustion engines. It has less than half the energy density of Natural Gas.

SynGas can be produced from many sources, including Natural Gas, Coal, Biomass, or virtually any Hydrocarbon feedstock, by reaction with steam (Steam Reforming), Carbon Dioxide (Dry Reforming) or Oxygen (Partial Oxidation). SynGas is a crucial intermediate resource for production of Hydrogen, Ammonia, Methanol, and Synthetic Hydrocarbon fuels. SynGas is also used as an intermediate in producing Synthetic Petroleum for use as a fuel or lubricant via the *Fischer–Tropsch* process.

Production methods include Steam Reforming of Natural Gas or liquid Hydrocarbons to produce Hydrogen, the Gasification of Coal, Biomass, and in some types of waste-to-energy Gasification facilities.

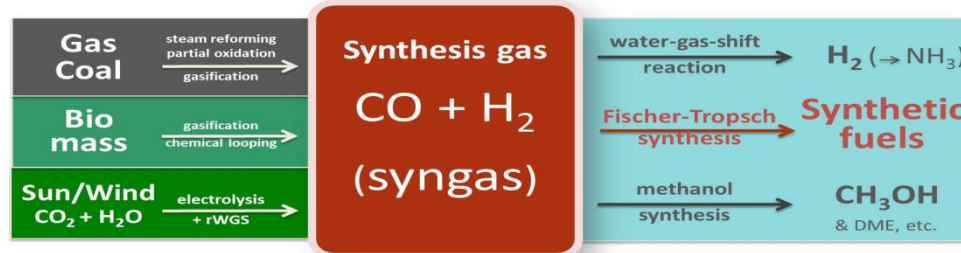

Transformative Power Plant – Polygeneration

The “Building Blocks”

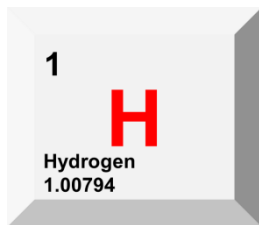

Hydrogen is a chemical element with symbol **H** and atomic number 1. With a standard atomic weight of 1.008, Hydrogen is the lightest element on the Periodic Table. Its monatomic form (H) is the most abundant chemical substance in the Universe, constituting roughly 75% of all mass. The most common isotope (Isotopes are variants of a particular chemical element which differ in neutron number. All isotopes of a given element have the same number of protons in each atom) of Hydrogen, termed *Protium* (name rarely used, symbol ^1H), has one proton and no neutrons.

The universal emergence of atomic Hydrogen first occurred during the recombination epoch. At standard temperature and pressure, Hydrogen is a colourless, odourless, tasteless, non-toxic, non-metallic, highly combustible diatomic gas with the molecular formula H_2 (Molecular Hydrogen).

Since hydrogen readily forms covalent compounds with most non-metallic elements, most of the hydrogen on Earth exists in molecular forms such as water or organic compounds. Hydrogen plays a particularly important role in acid–base reactions because most acid–base reactions involve the exchange of protons between soluble molecules. In ionic compounds, Hydrogen can take the form of a negative charge (i.e., anion) when it is known as a Hydride, or as a positively charged (i.e., cation) species denoted by the symbol H^+ . The Hydrogen cation is written as though composed of a bare proton, but in reality, Hydrogen cations in ionic compounds are always more complex.

Hydrogen gas was first artificially produced in the early 16th century by the reaction of acids on metals. In 1766–81, Henry Cavendish was the first to recognize that Hydrogen gas was a discrete substance, and that it produces water when burned, the property for which it was later named: in Greek, Hydrogen means "*water-former*".

Transformative Power Plant – Polygeneration

The “Building Blocks”

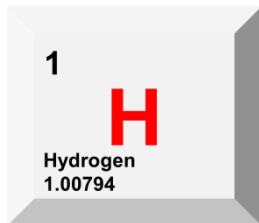

Industrial production is mainly from Steam Reforming of Natural Gas, and less often from more energy-intensive methods such as the Electrolysis of water. Most Hydrogen is used near the site of its production, the two largest uses being fossil fuel processing (e.g., Hydrocracking) and Ammonia production, mostly for the fertilizer market. Hydrogen is a concern in metallurgy as it can embrittle many metals, complicating the design of pipelines and storage tanks.

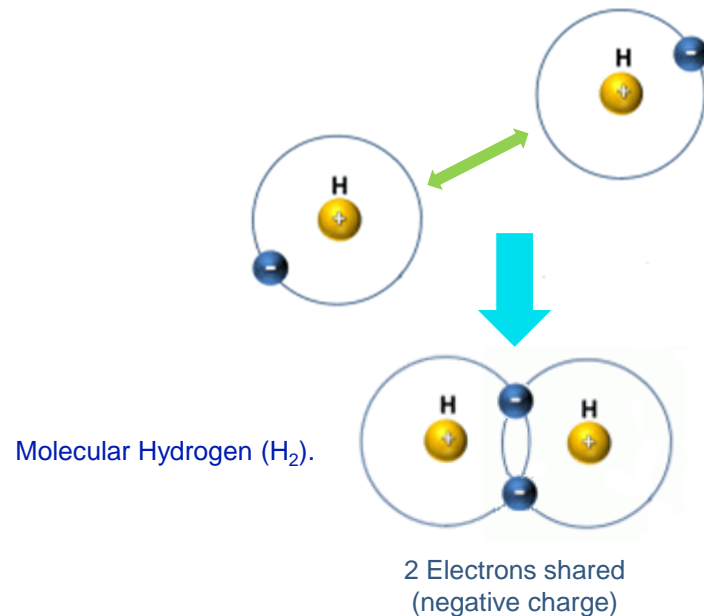
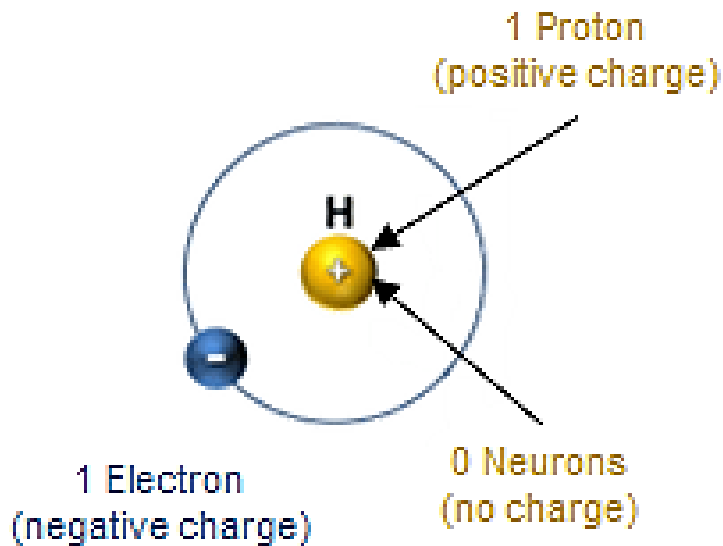

Transformative Power Plant – Polygeneration

The “Building Blocks”

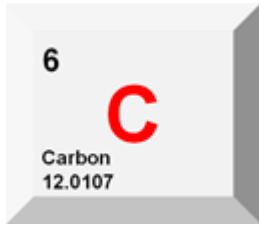

Carbon (from Latin: *carbo* "coal") is a chemical element with symbol **C** and atomic number 6. It is non-metallic and tetravalent—making four electrons available to form covalent chemical bonds. It belongs to group 14 of Periodic Table. Three isotopes occur naturally, ^{12}C and ^{13}C being stable, while ^{14}C is a radionuclide, decaying with a half-life of about 5,730 years. Carbon is one of the few elements known since antiquity.

Carbon is the 15th most abundant element in the Earth's crust, and the fourth most abundant element in the universe by mass after Hydrogen, Helium, and Oxygen. Carbon's abundance, its unique diversity of organic compounds, and its unusual ability to form polymers at the temperatures commonly encountered on Earth enables this element to serve as a common element of all known life. It is the second most abundant element in the human body by mass (about 18.5%) after Oxygen.

The atoms of Carbon can bond together in different ways, termed allotropes of carbon. The best known are Graphite, Diamond, and Amorphous Carbon. The physical properties of Carbon vary widely with the allotropic form. For example, Graphite is opaque and black while Diamond is highly transparent.

Graphite is soft enough to form a streak on paper (hence its name, from the Greek verb "*γράφειν*" which means "*to write*"), while Diamond is the hardest naturally occurring material known. Graphite is a good electrical conductor while Diamond has a low electrical conductivity. Under normal conditions, Diamond, Carbon Nanotubes, and Graphene have the highest thermal conductivities of all known materials. All Carbon allotropes are solids under normal conditions, with Graphite being the most thermodynamically stable form. They are chemically resistant and require high temperature to react even with Oxygen.

Transformative Power Plant – Polygeneration

The “Building Blocks”

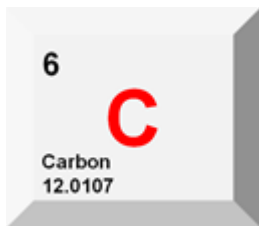

The most common oxidation state of Carbon in inorganic compounds is +4, while +2 is found in Carbon Monoxide (CO) and transition metal Carbonyl complexes. The largest sources of inorganic Carbon are Limestone, Dolomites and Carbon Dioxide (CO₂), but significant quantities occur in organic deposits of Coal, Peat, Oil, and Methane Clathrates (a Clathrate is a chemical substance consisting of a lattice that traps or contains molecules. Methane Clathrate (CH₄·5.75H₂O) or (4CH₄·23H₂O), also called Methane Hydrate, Hydromethane, Methane Ice, Fire Ice, Natural Gas Hydrate, or Gas Hydrate, is a solid Clathrate compound (more specifically, a Clathrate Hydrate) in which a large amount of Methane is trapped within a crystal structure of water, forming a solid similar to ice. Originally thought to occur only in the outer regions of the Solar System, where temperatures are low and water ice is common, significant deposits of Methane Clathrate have been found under sediments on the ocean floors of the Earth). Carbon forms a vast number of compounds, more than any other element, with almost ten million compounds described to date, and yet that number is but a fraction of the number of theoretically possible compounds under standard conditions. For this reason, Carbon has often been referred to as the "king of the elements".

Typical Carbon atom has six protons (positive charge) and six neutrons (no charge), and it has an atomic weight of 12 amu. The weight of an atom in atomic mass units (amu) is approximately the sum of its protons and neutrons, since the electrons don't have much mass. A Carbon also has six electrons (negative charge), but they are so small that they don't contribute to carbon's weight. Some Carbon atoms have an extra neutron or two, so Carbon may have an atomic weight of 13 or even 14 amu. However, a Carbon atom can't have an extra proton; an extra proton would make it a Nitrogen atom. It is the six protons that make the atom behave like Carbon. Many other elements may have slightly different atomic weights, depending on how many neutrons are found in the nucleus. Different atoms of the same element with different weights are called isotopes. For example, ¹²C, ¹³C and ¹⁴C are all isotopes of Carbon.

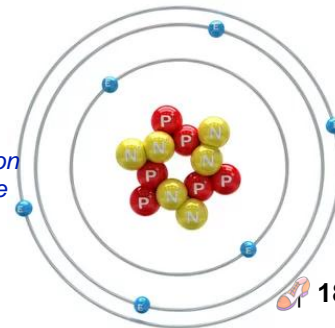

Transformative Power Plant – Polygeneration

The “Building Blocks”

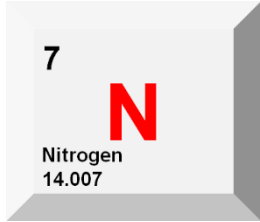

Nitrogen is a chemical element with symbol **N** and atomic number 7. It is a common element in the universe, estimated at about seventh in total abundance in the Solar System. At standard temperature and pressure, two atoms of the element bind to form **Dinitrogen**, a colourless and odourless diatomic gas with the formula N_2 . Dinitrogen forms about 78% of Earth's atmosphere, making it the most abundant uncombined element. Nitrogen occurs in all organisms, primarily in Amino Acids (and thus Proteins), in the Nucleic Acids (DNA and RNA) and in the energy transfer molecule Adenosine Triphosphate. The Nitrogen Cycle describes movement of the element from the air, into the biosphere and organic compounds, then back into the atmosphere.

Many industrially important compounds, such as Ammonia, Nitric Acid, organic Nitrates

(propellants and explosives), and Cyanides, contain Nitrogen. The majority of industrial Nitrogen is used to manufacture Ammonia (NH_3) via the **Haber process**. The extremely strong triple bond in elemental Nitrogen ($N\equiv N$), the second strongest bond in any diatomic molecule after Carbon Monoxide (CO), dominates Nitrogen chemistry. This causes difficulty for both organisms and industry in converting N_2 into useful compounds, but at the same time means that burning, exploding, or decomposing Nitrogen compounds to form **Nitrogen gas** releases large amounts of often useful energy. Synthetically produced Ammonia and Nitrates are key industrial fertilisers, and fertiliser Nitrates are key pollutants in the eutrophication of water systems.

Transformative Power Plant – Polygeneration

The “Building Blocks”



Apart from its use in fertilisers and energy-stores, Nitrogen is a constituent of organic compounds as diverse as Kevlar used in high-strength fabric and Cyanoacrylate used in superglue. Nitrogen is a constituent of every major pharmacological drug class, including antibiotics. Many drugs are mimics or prodrugs of natural nitrogen-containing signal molecules: for example, the organic Nitrates Nitro-Glycerine and Nitroprusside control blood pressure by metabolizing into Nitric Oxide. Many notable Nitrogen-containing drugs, such as the natural Caffeine and Morphine or the synthetic amphetamines, act on receptors of animal neurotransmitters.

An average atom of Nitrogen contains **7 protons**, **7 neutrons** and **7 electrons**

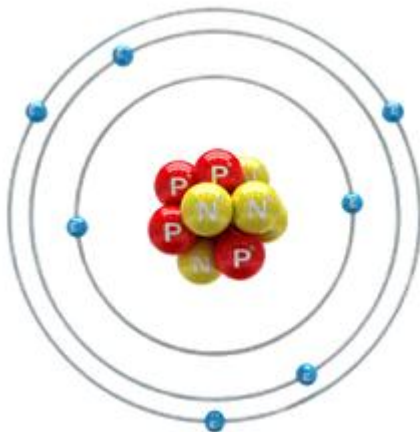

Transformative Power Plant – Polygeneration

The “Building Blocks”

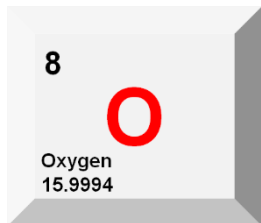

Oxygen is a chemical element with symbol **O** and atomic number 8. It is a member of the Chalcogen group (Oxygen (O), Sulphur (S), Selenium (Se), Tellurium (Te), and the radioactive element Polonium (Po)) on the Periodic Table, a highly reactive non-metal, and an oxidizing agent that readily forms Oxides with most elements as well as with other compounds. By mass, Oxygen is the third-most abundant element in the Universe, after Hydrogen and Helium. At standard temperature and pressure, two atoms of the element bind to form Oxygen, a colourless and odourless diatomic gas with the formula O_2 . Diatomic oxygen gas constitutes 20.8% of the Earth's atmosphere. As compounds including Oxides, the element makes up almost half of the Earth's crust.

Dioxygen is used in cellular respiration and many major classes of organic molecules in living organisms contain Oxygen, such as proteins, nucleic acids, carbohydrates, and fats, as do the major constituent inorganic compounds of animal shells, teeth, and bone. Most of the mass of living organisms is Oxygen as a component of water, the major constituent of life forms. Oxygen is continuously replenished by Photosynthesis, which uses the energy of sunlight to produce Oxygen from water and Carbon Dioxide. Oxygen is too chemically reactive to remain a free element in air without being continuously replenished by the Photosynthetic action of living organisms. Another form (allotrope) of Oxygen, Ozone (O_3), strongly absorbs ultraviolet UVB radiation and the high-altitude Ozone layer helps protect the Biosphere from ultraviolet radiation. But Ozone is a pollutant near the surface where it is a by-product of smog.

Transformative Power Plant – Polygeneration

The “Building Blocks”

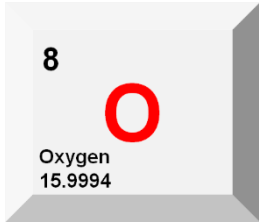

Oxygen was discovered independently by Carl Wilhelm Scheele, in Uppsala, in 1773 or earlier, and Joseph Priestley in Wiltshire, in 1774, but Priestley is often given priority because his work was published first. The name *Oxygen* was coined in 1777 by Antoine Lavoisier, whose experiments with Oxygen helped to discredit the then-popular phlogiston theory of combustion and corrosion. Its name derives from the Greek roots *ὀξύς* *oxys*, "acid", literally "sharp", referring to the sour taste of acids and *-γενής* *-genes*, "producer", literally "begetter", because at the time of naming, it was mistakenly thought that all acids required Oxygen in their composition.

Common uses of Oxygen include residential heating, internal combustion engines, production of steel, plastics and textiles, brazing, welding and cutting of steels and other metals, rocket propellant, Oxygen therapy, and life support systems in aircraft, submarines, spaceflight and diving.

An average atom of Oxygen contains **8 protons**, **8 electrons** and **8 neutrons**.



Transformative Power Plant – Polygeneration

The Products

Methane : is a **chemical** compound with the **chemical** formula CH_4 (one atom of Carbon – C and four atoms of Hydrogen - H). It is a group -14 Hydride and the simplest alkane, and is the main constituent of Natural Gas.

Ammonia or Azane : is a compound of Nitrogen (N) and Hydrogen (H) with the formula NH_3 . The simplest Pnictogen Hydride, **Ammonia** is a colourless gas with a characteristic pungent smell. Household **Ammonia** or Ammonium Hydroxide is a solution of NH_3 in water.

The global industrial production of Ammonia in 2014 was 176 million tonnes, a 16% increase over the 2006 global industrial production of 152 million tonnes. Industrial Ammonia is sold either as Ammonia liquor (usually 28% Ammonia in water) or as pressurized or refrigerated Anhydrous Liquid Ammonia transported in tank cars or cylinders.

NH_3 boils at $-33.34\text{ }^\circ\text{C}$ at a pressure of one atmosphere, so the liquid must be stored under pressure or at low temperature. Household Ammonia or Ammonium Hydroxide is a solution of NH_3 in water. The concentration of such solutions is measured in units of the Baumé scale (density), with 26 degrees Baumé (about 30% (by weight) Ammonia at $15.5\text{ }^\circ\text{C}$) being the typical high-concentration commercial product

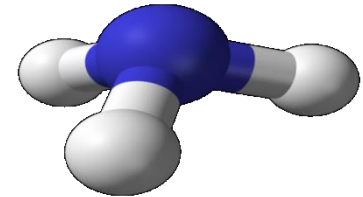
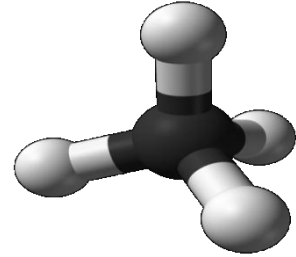

*Hydrogen (H) = white,
Nitrogen (N) = blue,
Oxygen (O) = red,
Carbon (C) = black*

Transformative Power Plant – Polygeneration

The Products

Urea, also known as **Carbamide**, is an organic compound with chemical formula $\text{CO}(\text{NH}_2)_2$. This amide has two NH_2 groups joined by a Carbonyl ($\text{C}=\text{O}$) functional group.

Urea serves an important role in the metabolism of Nitrogen-containing compounds by animals and is the main Nitrogen-containing substance in the urine of mammals. It is a colourless, odourless solid, highly soluble in water, and practically non-toxic (LD_{50} is 15 g/kg for rats). Dissolved in water, it is neither acidic nor alkaline. Urea is widely used in fertilizers as a source of Nitrogen and is an important raw material for the chemical industry.

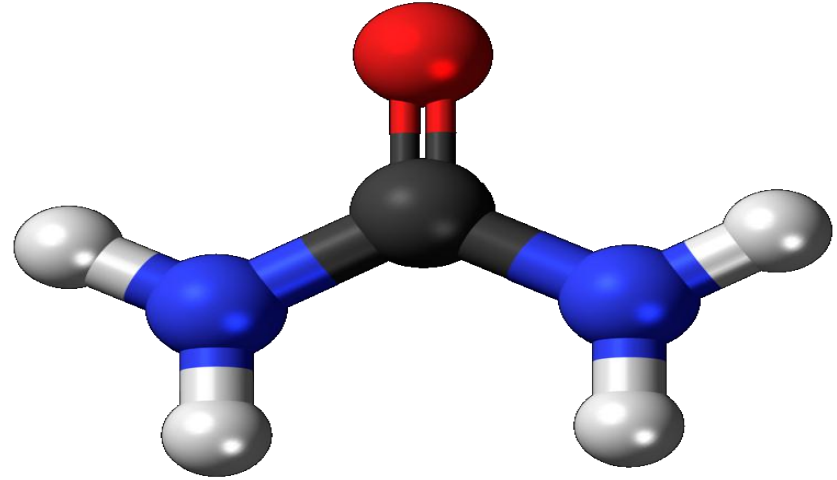

Hydrogen (H) = white, Nitrogen (N) = blue, Oxygen (O) = red, Carbon (C) = black

Transformative Power Plant – Polygeneration

The Products

Nitric acid (HNO_3), also known as **Aqua Fortis** and **Spirit of Niter** : is a highly corrosive mineral acid. The pure compound is colourless, but older samples tend to acquire a yellow cast due to decomposition into oxides of Nitrogen and water. Most commercially available Nitric Acid has a concentration of 68% in water. When the solution contains more than 86% HNO_3 , it is referred to as *Fuming Nitric Acid*. Depending on the amount of Nitrogen Dioxide present, Fuming Nitric Acid is further characterized as White Fuming Nitric Acid or Red Fuming Nitric Acid, at concentrations above 95%.

Nitric Acid is the primary reagent used for Nitration – the addition of a Nitro group, typically to an organic molecule. While some resulting Nitro compounds are shock- and thermally-sensitive explosives, a few are stable enough to be used in munitions and demolition, while others are still more stable and used as pigments in inks and dyes. Nitric Acid is also commonly used as a strong oxidizing agent.

Hydrogen (H) = white, Nitrogen (N) = blue, Oxygen (O) = red

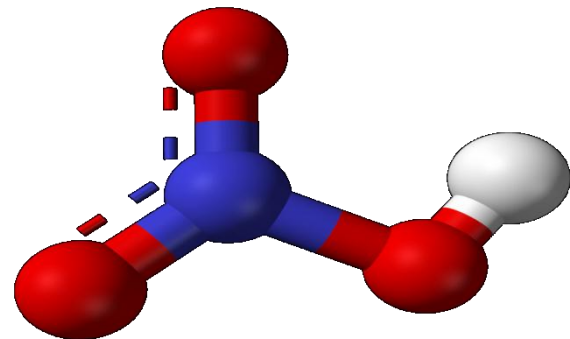

Transformative Power Plant – Polygeneration

The Products

Ammonium Nitrate is a chemical compound, the Nitrate Salt of the Ammonium Cation. It has the chemical formula NH_4NO_3 , simplified to $\text{N}_2\text{H}_4\text{O}_3$. It is a white crystal solid and is highly soluble in water. It is predominantly used in agriculture as a high-nitrogen fertilizer. Its other major use is as a component of explosive mixtures used in mining, quarrying, and civil construction. It is the major constituent of Ammonium Nitrate Fuel Oil mixture (ANFO), a popular industrial explosive which accounts for 80% of explosives used in North America.

Hydrogen (H) = white, Nitrogen (N) = blue, Oxygen (O) = red

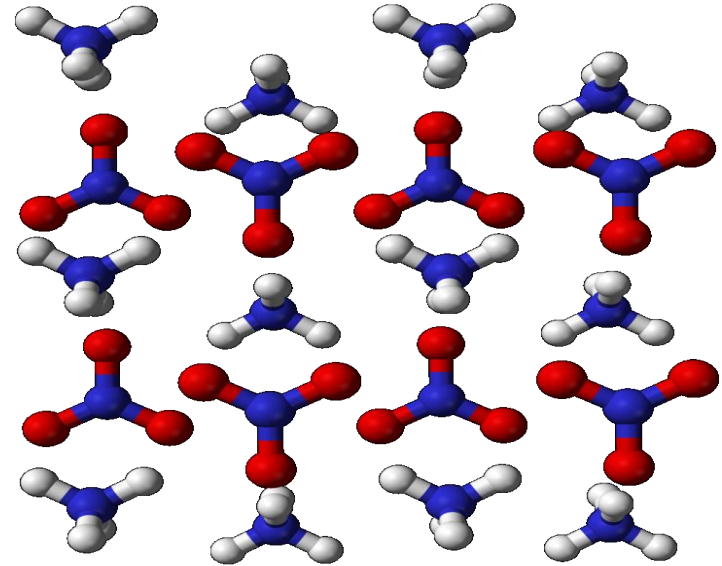

Transformative Power Plant – Polygeneration

The Products

Carbon Monoxide (CO) is a colourless, odourless, and tasteless gas that is slightly less dense than air. It is toxic to hemoglobin animals (both invertebrate and vertebrate, including humans) when encountered in concentrations above about 35 ppm, although it is also produced in normal animal metabolism in low quantities, and is thought to have some normal biological functions. In the atmosphere, it is spatially variable and short lived, having a role in the formation of ground-level Ozone.

Carbon Monoxide consists of one Carbon atom and one Oxygen atom, connected by a triple bond that consists of two covalent bonds as well as one dative covalent bond. It is the simplest Oxocarbon and is isoelectronic with the Cyanide anion, the Nitrosonium cation and molecular Nitrogen. In coordination complexes the Carbon Monoxide ligand is called Carbonyl.

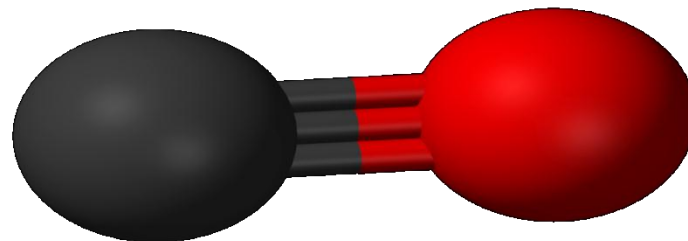

Hydrogen (H) = white, Nitrogen (N) = blue, Oxygen (O) = red

Transformative Power Plant – Polygeneration

The Products

Carbon dioxide (chemical formula CO_2) is a colourless gas with a density about 50% higher than that of dry air. Carbon Dioxide consists of a Carbon atom covalently double bonded to two Oxygen atoms. It occurs naturally in Earth's atmosphere as a trace gas at a concentration of about 0.04 percent (400 ppm) by volume. Natural sources include volcanoes, hot springs and geysers, and it is freed from Carbonate rocks by dissolution in water and acids. Because Carbon Dioxide is soluble in water, it occurs naturally in groundwater, rivers and lakes, ice caps, glaciers and seawater. It is present in deposits of Petroleum and Natural Gas. Carbon Dioxide is odourless at normally encountered concentrations, however at high concentrations it has a sharp and acidic odour.

As the source of available Carbon in the Carbon Cycle, atmospheric carbon dioxide is the primary Carbon source for life on Earth and its concentration in Earth's pre-industrial atmosphere since late in the Precambrian has been regulated by photosynthetic organisms and geological phenomena. Plants, algae and cyanobacteria use light energy to Photosynthesize Carbohydrate from Carbon Dioxide and water, with Oxygen produced as a waste product.

Carbon Dioxide (CO_2) is produced by all aerobic organisms when they metabolize carbohydrates and lipids to produce energy by respiration. It is returned to water via the gills of fish and to the air via the lungs of air-breathing land animals, including humans. Carbon Dioxide is produced during the processes of decay of organic materials and the fermentation of sugars in bread, beer and winemaking. It is produced by combustion of wood and other organic materials and fossil fuels such as coal, peat, petroleum and Natural Gas. On the other hand, it is an unwanted by-product in many large scale oxidation processes, for example the production of Acrylic Acid (over 5 million tons/year).

Transformative Power Plant – Polygeneration

The Products

Carbon dioxide : It is a versatile industrial material, used, for example, as an inert gas in welding and fire extinguishers, as a pressurizing gas in air guns and oil recovery, as a chemical feedstock and as a supercritical fluid solvent in decaffeination of coffee and supercritical drying. It is added to drinking water and carbonated beverages including beer and sparkling wine to add effervescence. The frozen solid form of CO₂, known as *dry ice* is used as a refrigerant and as an abrasive in dry-ice blasting.

Carbon dioxide is the most significant long-lived greenhouse gas in Earth's atmosphere. Since the Industrial Revolution anthropogenic emissions – primarily from use of fossil fuels and deforestation – have rapidly increased its concentration in the atmosphere, leading to global warming. The CO₂ released into the atmosphere as a result of the use of fossil fuels "represents 99.4% of CO₂ emissions in 2013". Carbon dioxide also causes ocean acidification because it dissolves in water to form carbonic acid.

Hydrogen (H) = white, Nitrogen (N) = blue, Oxygen (O) = red

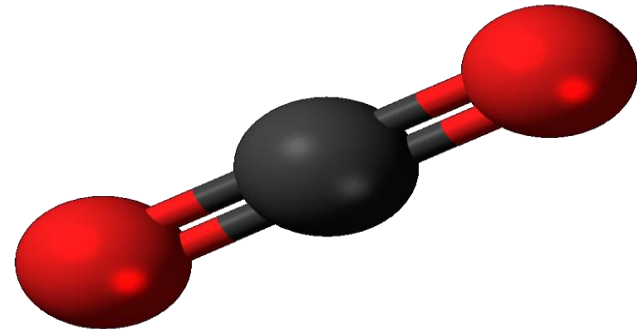

Transformative Power Plant – Polygeneration

The Products

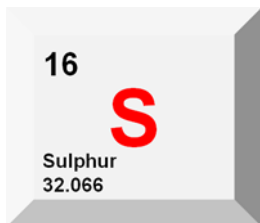

Sulphur : is a chemical element with symbol S and atomic number 16. It is abundant, multivalent, and nonmetallic. Under normal conditions, sulphur atoms form cyclic octatomic molecules with a chemical formula S₈. Elemental Sulphur is a bright yellow crystalline solid at room temperature. Chemically, Sulphur reacts with all elements except for Gold, Platinum, Iridium, Tellurium, and the Noble Gases.

Though sometimes found in pure, native form, Sulphur usually occurs as Sulphide (Sulphide) is an inorganic anion of Sulphur with the chemical formula S²⁻ or a compound containing one or more S²⁻ ions. It contributes no colour to Sulphide salts. As it is classified as a strong base, even dilute solutions of salts such as sodium sulphide (Na₂S) are corrosive and can attack the skin. Sulphide is the simplest Sulphur anion), and sulphate (Sulphate ion is a polyatomic anion with the empirical formula SO₄²⁻. Salts, acid derivatives, and peroxides of Sulphate are widely used in industry. Sulphates occur widely in everyday life. Sulphates are salts of Sulphuric Acid and many are prepared from that acid) minerals.

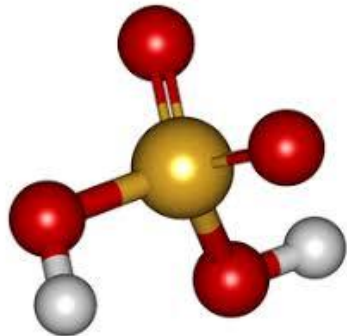

Sulphuric Acid : H₂SO₄
Hydrogen (H) = white, Sulphur (S) = yellow, Oxygen (O) = red

Transformative Power Plant – Polygeneration

The Products



Today, almost all elemental sulphur is produced as a by-product of removing sulphur-containing contaminants from natural gas and petroleum. **Dependant on the feedstock composition, Sulphur may be a by-product of Gasification.** The greatest commercial use of the element is the production of sulphuric acid (H_2SO_4) for sulphate and phosphate fertilizers, and other chemical processes. The element sulphur is used in matches, insecticides, and fungicides. Many sulphur compounds are odoriferous, and the smells of odorized natural gas, skunk scent, grapefruit, and garlic are due to Organo-sulphur compounds. Hydrogen Sulphide (H_2S) gives the characteristic odor to rotting eggs and other biological processes.

Sulphur is an essential element for all life, but almost always in the form of Organosulphur compounds or metal Sulphides. Three amino acids (Cysteine, Cystine, and Methionine) and two vitamins (Biotin and Thiamine) are Organosulphur compounds. Many cofactors also contain Sulphur including glutathione and Thioredoxin and Iron–sullphur proteins. Disulphides, S–S bonds, confer mechanical strength and insolubility of the protein Keratin, found in outer skin, hair, and feathers. Sulphur is one of the core chemical elements needed for biochemical functioning and is an elemental macronutrient for all living organisms.

Sulphuric Acid : Elemental Sulphur is used mainly as a precursor to other chemicals. Approximately 85% (1989) is converted to Sulphuric Acid (H_2SO_4):



Transformative Power Plant – Polygeneration

The Products

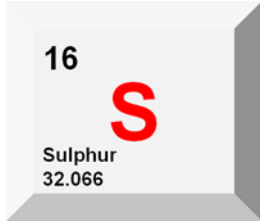

In 2010, the United States produced more Sulphuric acid than any other inorganic industrial chemical. The principal use for the Acid is the extraction of Phosphate ores for the production of fertilizer manufacturing. Other applications of Sulphuric Acid include oil refining, wastewater processing, and mineral extraction.

Other important Sulphur chemistry : Sulphur reacts directly with methane to give Carbon Disulphide, used to manufacture cellophane and rayon. One of the direct uses of Sulphur is in vulcanization of rubber, where Polysulphide chains crosslink organic polymers. Large quantities of Sulphites are used to bleach paper and to preserve dried fruit. Many surfactants and detergents (e.g. Sodium Lauryl Sulphate) are sulphate derivatives. Calcium Sulphate, Gypsum, ($\text{CaSO}_4 \cdot 2\text{H}_2\text{O}$) is mined on the scale of 100 million tonnes each year for use in Portland Cement and fertilizers. Sulphur is a component of gunpowder ("black powder").

Fertilizer : Sulphur is increasingly used as a component of fertilizers. The most important form of Sulphur for fertilizer is the mineral. Calcium Sulphate (CaSO_4). Elemental Sulphur is hydrophobic (not soluble in water) and cannot be used directly by plants. Over time, soil bacteria can convert it to soluble derivatives, which can then be used by plants. Sulphur improves the efficiency of other essential plant nutrients, particularly Nitrogen and Phosphorus. Biologically produced Sulphur particles are naturally hydrophilic due to a biopolymer coating and are easier to disperse over the land in a spray of diluted slurry, resulting in a faster uptake.

Transformative Power Plant – Polygeneration

The Products

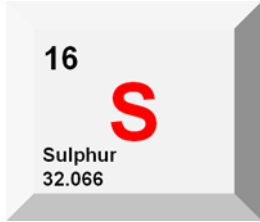

The botanical requirement for Sulphur equals or exceeds the requirement for Phosphorus. It is an essential nutrient for plant growth, root nodule formation of legumes, and immunity and defence systems. Sulphur deficiency has become widespread in many countries in Europe. Because atmospheric inputs of Sulphur continue to decrease, the deficit in the Sulphur input/output is likely to increase unless Sulphur fertilizers are used.

Fine chemicals : Organo sulfur compounds are used in pharmaceuticals, dyestuffs, and agrochemicals. Many drugs contain Sulphur, early examples being antibacterial sulfonamides, known as sulfa drugs. Sulfur is a part of many bacterial defense molecules. Most β -lactam antibiotics, including the penicillins, cephalosporins and monolactams contain Sulphur.

Magnesium sulfate, known as Epsom salts when in hydrated crystal form, can be used as a laxative, a bath additive, an exfoliant, magnesium supplement for plants, or (when in dehydrated form) as a desiccant.

Transformative Power Plant – Polygeneration

The Products



Fungicide and pesticide : Elemental Sulphur is one of the oldest fungicides and pesticides. "Dusting Sulphur", elemental Sulphur in powdered form, is a common fungicide for grapes, strawberry, many vegetables and several other crops. It has a good efficacy against a wide range of powdery mildew diseases as well as black spot. In organic production, Sulphur is the most important fungicide. It is the only fungicide used in organically farmed apple production against the main disease apple scab under colder conditions. Biosulphur (biologically produced elemental Sulphur with hydrophilic characteristics) can also be used for these applications.

Standard-formulation dusting Sulphur is applied to crops with a Sulphur duster or from a dusting plane. Wettable Sulphur is the commercial name for Dusting Sulphur formulated with additional ingredients to make it water miscible. It has similar applications and is used as a fungicide against mildew and other mold-related problems with plants and soil.

Elemental Sulphur powder is used as an "organic" (i.e. "green") insecticide (actually an Acaricide) against ticks and mites. A common method of application is dusting the clothing or limbs with Sulphur powder.

A diluted solution of lime Sulphur (made by combining Calcium Hydroxide with Elemental Sulphur in water) is used as a dip for pets to destroy ringworm (fungus), mange, and other dermatoses and parasites.

Sulphur candles of almost pure Sulphur were burned to fumigate structures and wine barrels, but are now considered too toxic for residences.

Transformative Power Plant – Polygeneration

The Products



Bactericide in winemaking and food preservation : Small amounts of Sulphur Dioxide gas addition (or equivalent Potassium Metabisulphite addition) to fermented wine to produce traces of Sulphurous Acid (produced when SO_2 reacts with water) and its Sulphite salts in the mixture, has been called "the most powerful tool in winemaking." After the yeast-fermentation stage in winemaking, Sulphites absorb Oxygen and inhibit aerobic bacterial growth that otherwise would turn Ethanol into Acetic Acid, souring the wine. Without this preservative step, indefinite refrigeration of the product before consumption is usually required. Similar methods go back into antiquity but modern historical mentions of the practice go to the fifteenth century. The practice is used by large industrial wine producers and small organic wine producers alike.

Sulphur Dioxide and various Sulphites have been used for their antioxidant antibacterial preservative properties in many other parts of the food industry. The practice has declined since reports of an allergy-like reaction of some persons to Sulphites in foods.

Pharmaceuticals : Sulphur (specifically Octasulphur, S_8) is used in pharmaceutical skin preparations for the treatment of acne and other conditions. It acts as a Keratolytic agent and also kills bacteria, fungi, scabies mites and other parasites. Precipitated Sulphur and colloidal Sulphur are used, in form of lotions, creams, powders, soaps, and bath additives, for the treatment of acne vulgaris, acne rosacea, and seborrhoeic dermatitis.

Transformative Power Plant – Polygeneration

The Products

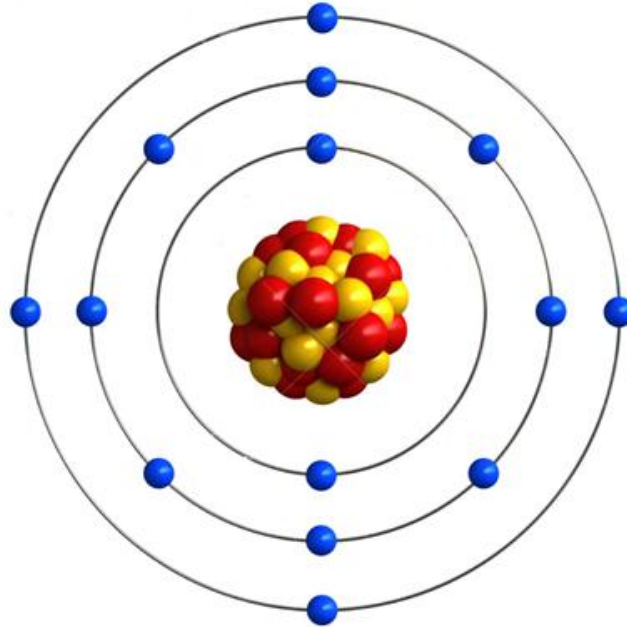

● 16 Protons ● 16 Neutrons ● 16 Electrons

Transformative Power Plant – Polygeneration

The Products

Water is a transparent and nearly colourless chemical substance that is the main constituent of Earth's streams, lakes, and oceans, and the fluids of most living organisms. Its chemical formula is H_2O , meaning that each of its molecules contains one oxygen and two hydrogen atoms that are connected by covalent bonds. Strictly speaking, water refers to the liquid state of a substance that prevails at standard ambient temperature and pressure; but it often refers also to its solid state (ice) or its gaseous state (steam or water vapour). It also occurs in nature as snow, glaciers, ice packs and icebergs, clouds, fog, dew, aquifers, and atmospheric humidity.

Water covers 71% of the Earth's surface. It is vital for all known forms of life. On Earth, 96.5% of the planet's crust water is found in seas and oceans, 1.7% in groundwater, 1.7% in glaciers and the ice caps of Antarctica and Greenland, a small fraction in other large water bodies, 0.001% in the air as vapour, clouds (formed of ice and liquid water suspended in air), and precipitation. Only 2.5% of this water is freshwater, and 98.8% of that water is in ice (excepting ice in clouds) and groundwater. Less than 0.3% of all freshwater is in rivers, lakes, and the atmosphere, and an even smaller amount of the Earth's freshwater (0.003%) is contained within biological bodies and manufactured products. A greater quantity of water is found in the earth's interior.

Water on Earth moves continually through the water cycle of evaporation and transpiration (evapotranspiration), condensation, precipitation, and runoff, usually reaching the sea. Evaporation and transpiration contribute to the precipitation over land. Large amounts of water are also chemically combined or adsorbed in hydrated minerals.

Transformative Power Plant – Polygeneration

The Products

Water : Safe drinking water is essential to humans and other life forms even though it provides no calories or organic nutrients. Access to safe drinking water has improved over the last decades in almost every part of the world, but approximately one billion people still lack access to safe water and over 2.5 billion lack access to adequate sanitation. However, some observers have estimated that by 2025 more than half of the world population will be facing water-based vulnerability. A report, issued in November 2009, suggests that by 2030, in some developing regions of the world, water demand will exceed supply by 50%.

Water plays an important role in the world economy. Approximately 70% of the freshwater used by humans goes to agriculture. Fishing in salt and fresh water bodies is a major source of food for many parts of the world. Much of long-distance trade of commodities (such as oil and natural gas) and manufactured products is transported by boats through seas, rivers, lakes, and canals. Large quantities of water, ice, and steam are used for cooling and heating, in industry and homes. Water is an excellent solvent for a wide variety of chemical substances; as such it is widely used in industrial processes, and in cooking and washing. Water is also central to many sports and other forms of entertainment, such as swimming, pleasure boating, boat racing, surfing, sport fishing, and diving.

Hydrogen (H) = white, Nitrogen (N) = blue, Oxygen (O) = red

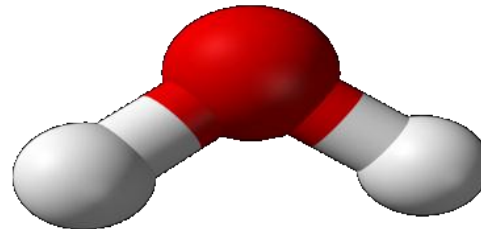

Transformative Power Plant

Interfacing With Ammonia Production

Truncated Process for the production of Ammonia from Gasification Products (Hydrogen and Nitrogen)

~~The Haber Bosch Ammonia Process~~

~~Natural Gas~~

PRODUCTION OF THE SYNTHESIS MIXTURE

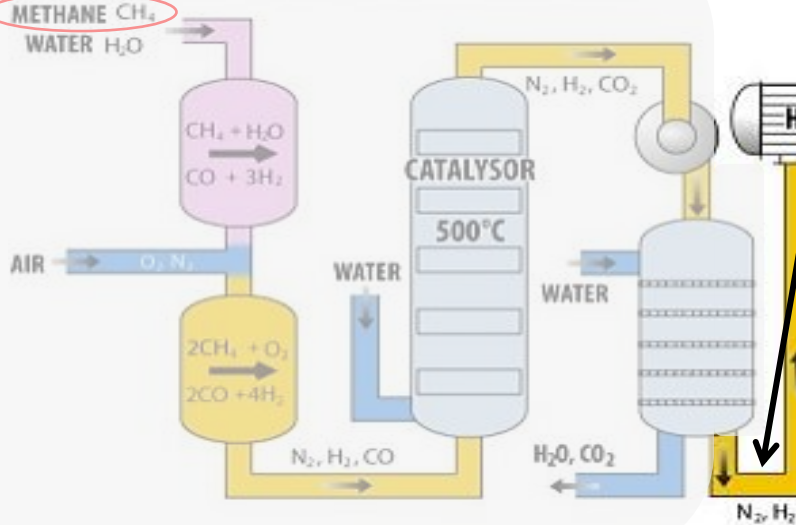

Introduction of Hydrogen (H_2) from SynGas + Nitrogen (N) from Air Separation step of Gasification.

PRODUCTION OF AMMONIA

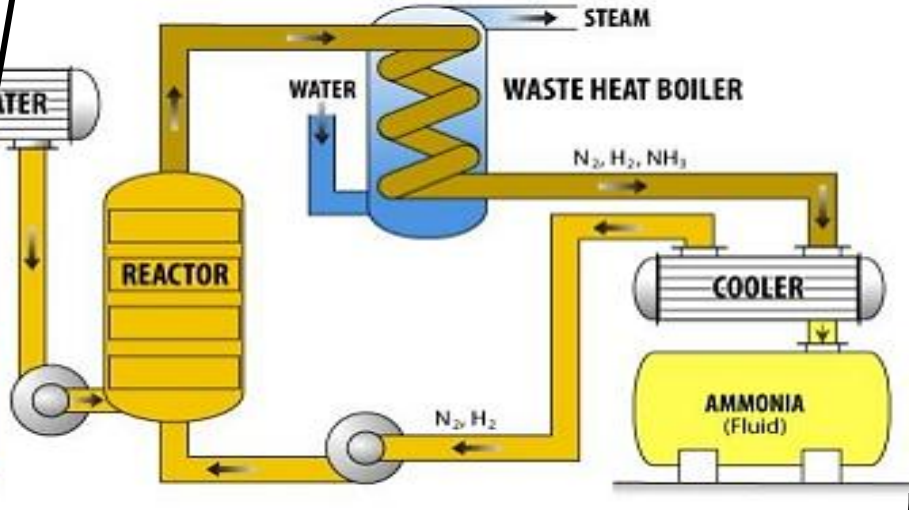

"Traditional" Process for the production of Ammonia from Natural Gas

Transformative Power Plant – Polygeneration

The Products

Natural Gas : The gross heating value of Natural Gas is the total heat obtained by complete combustion at constant pressure of a unit volume of gas in air, including the heat released by condensing the water vapour in the combustion products (gas, air, and combustion products taken at standard temperature and pressure).

Sulphur: The typical sulphur content is 5.5 mg/m³. This includes the 4.9 mg/m³ of sulphur in the odorant (Mercaptan) added to gas for safety reasons.

Water: The water vapour content of natural gas is typical less than 65 mg/m³, and is typically 16 to 32 mg/m³.

Typical Combustion Properties of Natural Gas (combustion properties at various locations in a Natural Gas network can vary. The properties shown should be taken as an average).

Ignition Point: 564 °C *

Flammability Limits: 4% - 15% (volume % in air) *

Theoretical Flame Temperature (stoichiometric air/fuel ratio): 1953 °C *

Maximum Flame Velocity: 0.36 m/s *

Transformative Power Plant – Polygeneration

The Products

Natural Gas : Natural Gas is a naturally occurring gas mixture, consisting mainly of Methane. The table below outlines the typical components of Natural Gas and the typical ranges for these values (allowing for the different sources).

Component	Typical Analysis (mole %)	Range (mole %)
Methane	93.9	87.0 - 97.0
Ethane	4.2	1.5 - 9.0
Propane	0.3	0.1 - 1.5
iso - Butane	0.03	0.01 - 0.3
normal - Butane	0.03	0.01 - 0.3
iso - Pentane	0.01	trace - 0.04
normal - Pentane	0.01	trace - 0.04
Hexanes plus	0.01	trace - 0.06
Nitrogen	1.0	0.2 - 5.5
Carbon Dioxide	0.5	0.05 - 1.0
Oxygen	0.01	trace - 0.1
Hydrogen	trace	trace - 0.02
Specific Gravity	0.59	0.57 - 0.62
Gross Heating Value (MJ/m ³), dry basis *	38.7	36.0 - 40.2
Wobbe Number (MJ/m ³)	50.4	47.5 - 51.5

Transformative Power Plant – Polygeneration

The Products – Constituents of Natural Gas

Methane (CH_4)

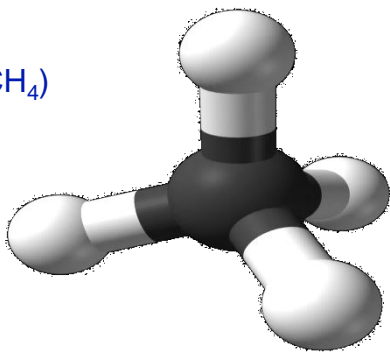

Ethane (C_2H_6)

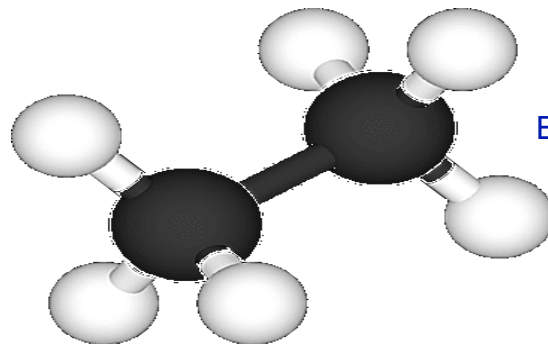

Hydrogen (H) = white, Carbon (C) = black

Propane (C_3H_8)

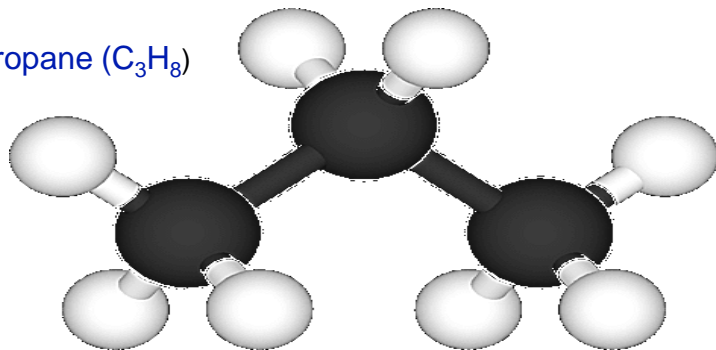

Butane (C_4H_{10})

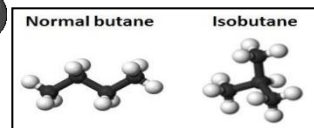
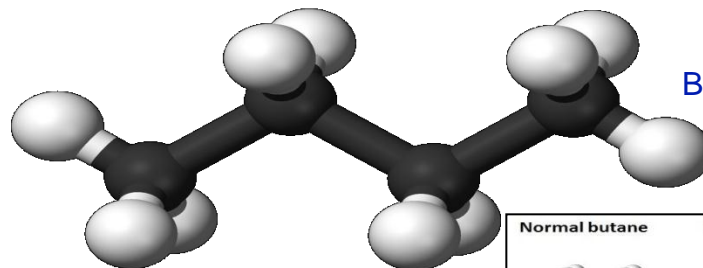

Transformative Power Plant – Polygeneration

The Products – Synthetic Natural Gas

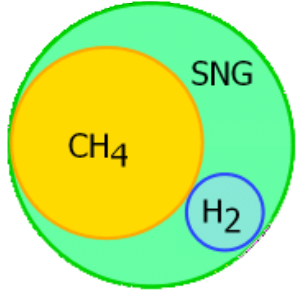

Synthetic Natural Gas (SNG) : A Coal Gasifier used in the production of Synthesis Gas (SynGas) that is then used to make Synthetic Natural Gas (SNG).

Synthetic Natural Gas is a type of gas created from Coal that serves as a substitute for Natural Gas and is suitable for transmission in Natural Gas pipelines. This natural gas substitute must have a minimum of 95% Methane in it.

Natural Gas is a major component of the world's energy supply, as it is used widely in residential, commercial, and industrial applications. However, the supply is limited and thus Synthetic Natural Gas is desirable where there is an absence or shortage and / or high prices for of Natural Gas in a region. This type of Natural Gas is desirable as it has combustion characteristics similar to Natural Gas, and because of this minimal changes need to be made to use Synthetic Natural Gas.

Synthetic natural gas is created through a thermo-chemical conversion. The first step in this conversion is the gasification of the solid carbon source, whether it be coal or biomass (which would create Bio-SNG), with steam or oxygen. Here the coal is burned with a limited supply of oxygen or air and the main product is carbon dioxide:

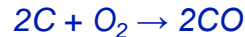

To reduce the amount of nitrogen in this gas, modern gas plants use pure oxygen for combustion. If steam is added to this pure oxygen then a water gas reaction occurs instead of the traditional combustion:



Transformative Power Plant – Polygeneration

The Products – Synthetic Natural Gas

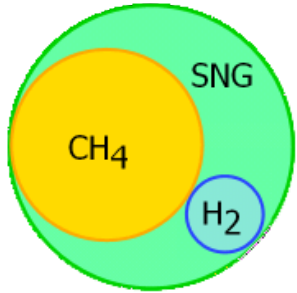

These processes drive off some of the volatile material, and the product is known as a Producer Gas. Generally, this occurs in a Gasifier which feeds Coal into a high pressure, high temperature vessel and distributes steam or Oxygen evenly while removing ash to Gasify the Coal. This Producer Gas is a mixture containing H₂, CO, CO₂, H₂O, and CH₄ along with other Hydrocarbons and some impurities. The exact composition of this Gas depends on the type of reactor used, operating conditions, and other processes during the gasification process. This gas also contains impurities such as oils, tars, Hydrogen Sulphide, and Ammonia which must be removed - although Ammonia levels are lower if the water gas reaction takes place.

To purify this Gas, it must undergo gas cleaning and gas conditioning. During gas cleaning, impurities such as Ammonia and Sulphur are removed from the Producer Gas whereas in gas conditioning is the process by which parts of the Producer Gas are converted so that the final composition of the Gas is suitable for its use. What is left after this cleaning and conditioning is useful Synthesis Gas (Carbon Monoxide and Hydrogen) plus some Methane, and Carbon Dioxide.

To finish making the synthetic natural gas, the SynGas must undergo Water Gas Shift reactions and Methanation. The Water Gas Shift reaction combines Carbon Monoxide with steam to create Carbon Dioxide and Hydrogen in the following reaction:



Transformative Power Plant – Polygeneration

The Products – Synthetic Natural Gas

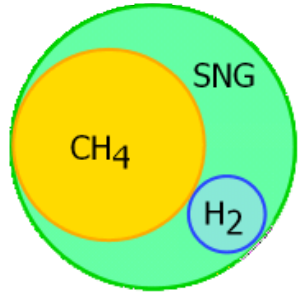

This reaction requires a metal catalyst to occur. Since the end "goal" of this Gas is to obtain Methane (the main component of Natural Gas) some of the Carbon Monoxide is retained, so the reaction does not go through to completion. At this point, the Carbon Dioxide is separated out using a type of scrubbing and only the final Methanation step remains. During Methanation, Carbon Monoxide reacts with the Hydrogen that was created with the help of a Nickel catalyst to create Methane and steam in the following reaction:



At this point, the Synthetic Natural Gas is complete after half of the original Carbon in the Coal has turned into Methane. The rest of the Carbon is turned into Carbon Dioxide.

Bio-SNG : Bio-SNG is produced similarly to regular Synthetic Natural Gas, but is instead made through the Gasification of Biomass. Biomass such as forestry residues or energy crops are used. To make Bio-SNG, Biomass is initially dried and goes through initial Gasification. After this, it undergoes gas conditioning, SNG synthesis, and finally Gas upgrading.

Transformative Power Plant – Polygeneration

The Products – Synthetic Natural Gas, The Methanation Process

Methanation : is a chemical reaction that converts carbon monoxide and/or carbon dioxide to methane. The production of methane across the “Sabatier” reaction (1) is a well-known process for converting CO₂ to a useful product and was proposed by Paul Sabatier and J.B. Sendersens in 1902. A large-scale production of methane on the basis of carbon dioxide has never been widely established and on basis of carbon monoxide just in a few plants. This is because of the up to date good availability and economy of natural gas. With the new development of the Power to Gas technology for an energy-efficient storage solution of Renewable Energy, Methanation gains a lot of importance.



The reaction is thermodynamically favoured at relatively low temperatures and high.

Carbon Monoxide (CO) conversion to Methane is described by:



that is namely the reverse Steam Reforming reaction or also called CO-Methanation. In effect, the Sabatier reaction can be seen as the sum of the CO-Methanation with the reverse WGS (Water Gas Shift reaction):



Transformative Power Plant – Polygeneration

The Products – Synthetic Natural Gas, The Methanation Process

Methanation : Methanation is nowadays revamped in a lot of projects of SynGas and Carbon Dioxide valorization. However, for CO₂-concentrated feed (with no dilution, the stoichiometric feed implies 20 % vol of CO₂ and 80 % vol. of H₂) the thermodynamic limitations appear to be very strong. The reaction (1) is highly exothermic and the adiabatic temperature raise connected to the reaction progress is quite high. For example the adiabatic equilibrium temperature of a stoichiometric CO₂ + 4H₂ feed at 30 bar and 25°C would be 724°C. So the greatest challenge involved in Methanation is the temperature control of the exothermic reactions, meaning an efficient heat removal, which is closely linked to Reactor design.

The Adiabatic Fixed Bed Reactor represents the simplest Reactor design option. The reactor is filled with catalytic pellets, and rather than being cooled its heat is instead used to increase the gas temperature. With that increased temperature the reaction rate is very high and therefore requires a relative small amount of catalyst. As temperature increases the chemical equilibrium of the Methane formation process shifts towards the reactants and the reaction comes to an equilibrium state at high temperatures which is not optimal for the CO₂ conversion depending on the prevailing pressure. However the adiabatic temperature might need to be limited to prevent catalyst destruction through thermal sintering. To limit the temperature raise, the Reactor feed gas can be diluted. Either with inert gas, a surplus of one reactant or product gas recycle. For example Reactor outlet gas can be recycled and shift the adiabatic temperature raise towards lower temperatures.

Transformative Power Plant – Polygeneration

The Products – Synthetic Natural Gas, The Methanation Process

Methanation : As CO₂ conversion rates are relatively low at high temperatures (approaching equilibrium, reverse reactions (1)-(3) become faster), a number of adiabatic Reactors connected in series are necessary to reach the target conversion. The gas is subjected to intermediate cooling prior to each catalytic Reactor with the advantage of using simple Fixed Bed Reactors that presents very low complexity and easy constructional design thanks to the adiabatic conditions adopted. On the other hand, the basic limit of a series of adiabatic Reactor with intermediate cooling is that a high number of stages are needed to achieve a satisfactorily conversion; when too many Reactors are necessary, such a solution becomes complex and expensive, while using few in-series stages, the limitation to conversion could be important.

The opposite solution for such a classical problem of exothermal reactions engineering is the design of a cooled Reactor setup (isothermal operation). In such a way, the highest Methane conversion would be virtually reached. One suitable option comes in the form of catalyst-filled pipe bundles surrounded by a circulating cooling medium in order to carry off heat. The use of boiling water as a cooling medium is widespread (e.g. in *Fischer-Tropsch* Reactors). Boiling water offers the advantages of highly intensive heat removal and therefore good isothermal conditions in the reactor tube, which in turn facilitate hot spot avoidance and a high level of control over cooling performance. One key disadvantage of using boiling water for the Methanation process is the high boiling water pressure required, which is dependent on the reaction temperature targeted.

Transformative Power Plant – Polygeneration

The Products – Synthetic Natural Gas, The Methanation Process

Methanation : Even more disadvantageous is the fact that an isothermal reactor does not provide high reaction rates for the CO_2 -Methanation also it would lead to the highest CO_2 conversion at equilibrium. The lower reactor temperatures lower the reaction rate with consequent increase of catalysts load, and reactor size in addition to the severely increased complexity of the inter-cooled system.

A reactor concept with more than one reactor gives the chance to remove reaction water and therefore shift the chemical equilibrium towards the products side.

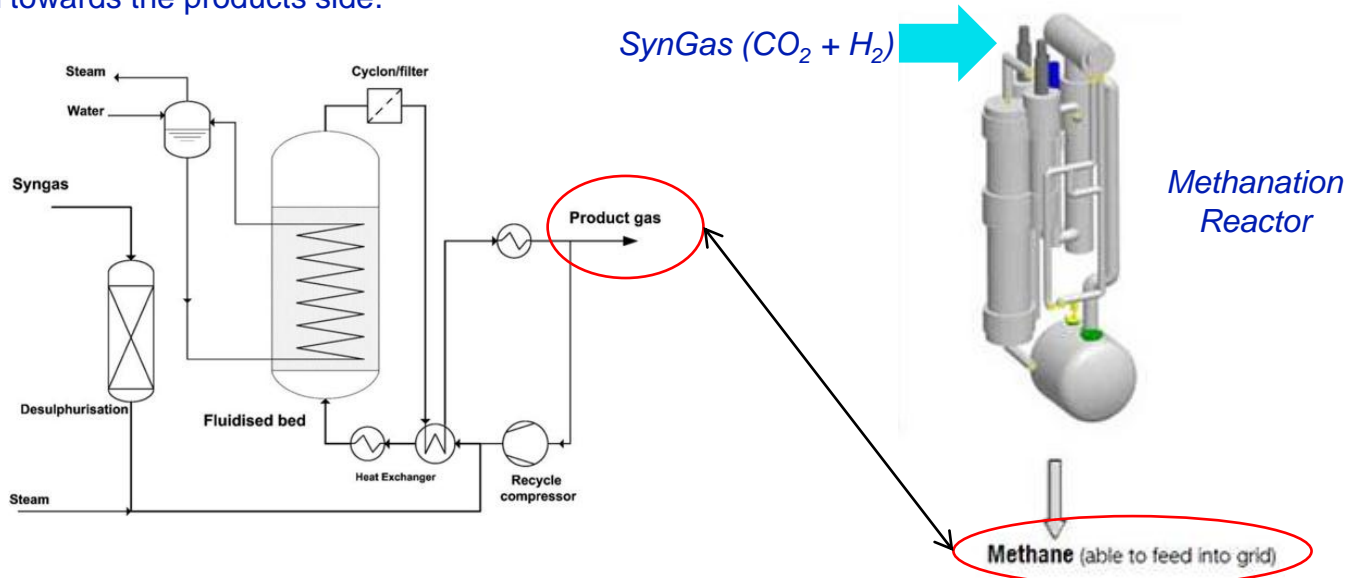



Background Information

“Traditional” Manufacture of Ammonia, Nitric Acid, Urea and Ammonium Nitrate

Manufacture of Ammonia, Nitric Acid, Urea and Ammonium Nitrate - *Ammonia*

The Haber Bosch Ammonia Process

Natural Gas

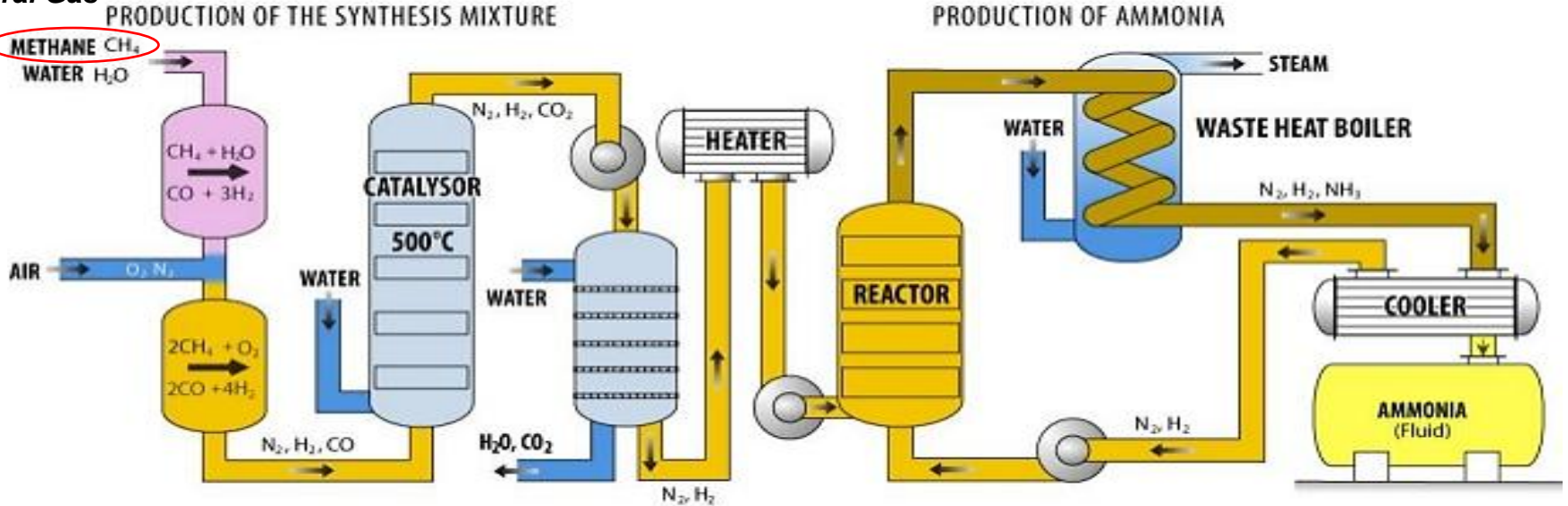

Manufacture of Ammonia, Nitric Acid, Urea and Ammonium Nitrate - *Urea*

Urea Production and Manufacturing Process : Urea was first produced industrially by the hydration of Calcium Cyanamide but the easy availability of Ammonia led to the development of Ammonia / Carbon Dioxide technology. This is a two step process where the Ammonia and Carbon Dioxide react to form Ammonium Carbamate which is then dehydrated to Urea.

In the process, ammonia and carbon dioxide are fed to the synthesis reactor which operates around 180-210 °C and 150 bar pressure. The reaction mixture containing Ammonia, Ammonium Carbamate and Urea is first stripped of the Ammonia and the resultant solution passes through a number of decomposers operating at progressively reduced pressures. Here the unconverted Carbamate is decomposed back to Ammonia and Carbon Dioxide and recycled to the reactor.

The Urea solution is concentrated by evaporation or crystallisation, and the crystals can be melted to yield pure Urea in the form of prills or granules. Prills are made by spraying molten Urea from the top of a high tower through a counter current air stream. Granular Urea is formed by spraying molten Urea into a mixture of dried Urea particles and fines in a rotating drum.

Urea processes fall into two categories: external solution recycle systems; and internal solution stripping systems. In the former, energy is saved by high Carbon Dioxide conversion rates while the latter reduces net energy requirements by optimising heat recovery.

Manufacture of Ammonia, Nitric Acid, Urea and Ammonium Nitrate - Urea

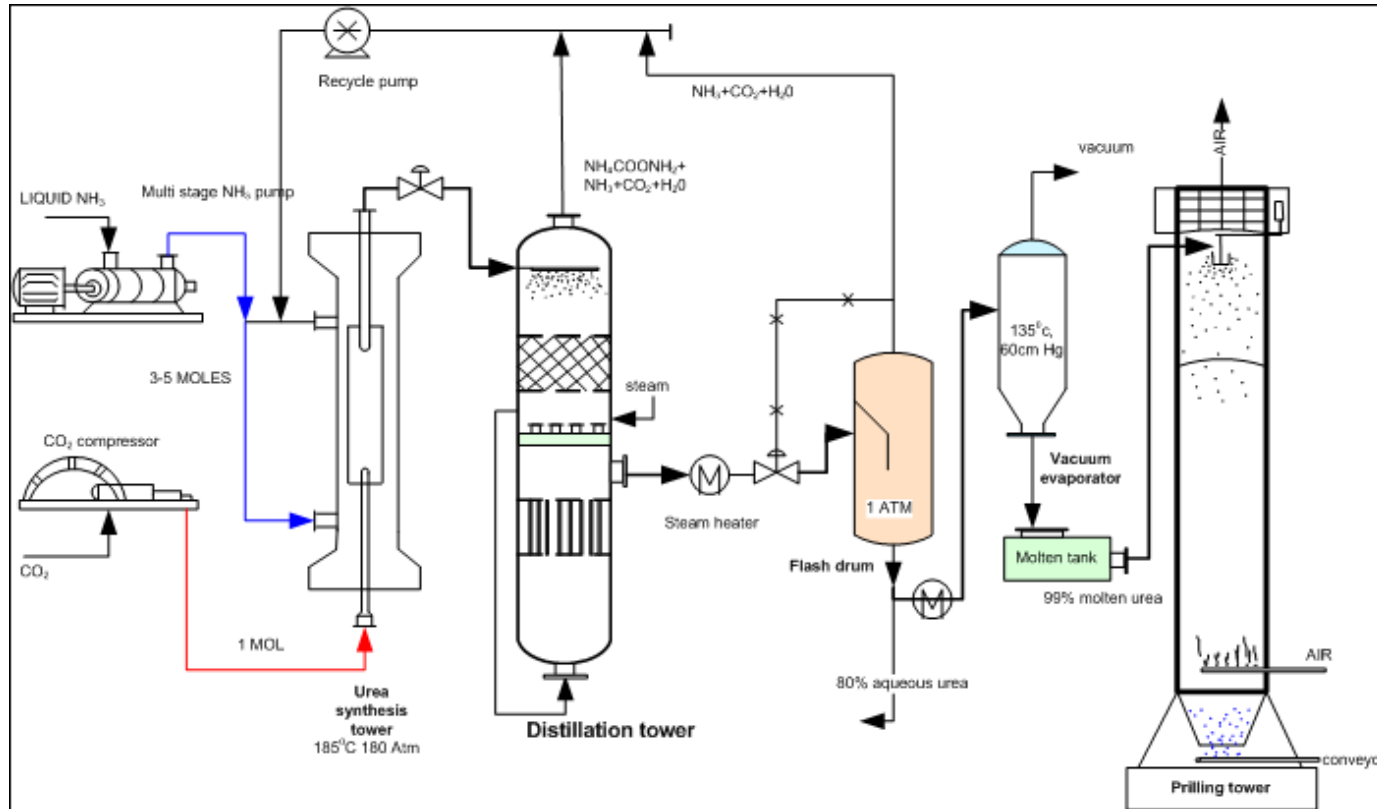

Manufacture of Ammonia, Nitric Acid, Urea and Ammonium Nitrate - *Nitric Acid*

Nitric Acid is a colourless liquid that is used in the manufacture of inorganic and organic Nitrates and Nitro compounds for fertilizers, dye intermediates, explosives, and many different organic chemicals. Nitric Acid is most commonly manufactured by Ostwald process. The Ostwald process converts Ammonia to Nitric Acid and involves two steps.

In step 1, Ammonia is oxidized to form Nitric Oxide and also Nitrogen Dioxide. Then in step 2, the Nitrogen Dioxide that was formed is absorbed in water. This in-turn forms Nitric Acid.

The Ostwald process has many well-known uses in both the industrial and health field. Through the Ostwald process, Nitric Acid is commonly used in fertilizers and pharmaceuticals, and because of its chemical reaction with some compounds it is used in rocket fuel and explosives like Trinitrotoluene (TNT).

Step 1—Primary oxidation (formation of Nitric Acid)

Oxidation of ammonia is carried out in a catalyst chamber in which one part of ammonia and eight parts of Oxygen by volume are introduced. The temperature of chamber is about 600 °C. This chamber contains a Platinum gauze which serves as catalyst.

Oxidization of Ammonia is reversible and exothermic process. Therefore according to Le-Chatelier's principle, a decrease in temperature favours reaction in forward direction. In primary oxidization 95 per cent of Ammonia is converted into Nitric Oxide (NO).



Manufacture of Ammonia, Nitric Acid, Urea and Ammonium Nitrate - *Nitric Acid*

Nitric Acid:



Step 2—Secondary oxidation (formation of Nitrogen Dioxide)

Nitric Oxide gas obtained by the oxidation of Ammonia is very hot. In order to reduce its temperature, it is passed through a heat exchanger where the temperature of Nitric Oxide is reduced to 150 °C. Nitric Oxide after cooling is transferred to another oxidizing tower where at about 50 °C it is oxidized to nitrogen dioxide (NO₂).

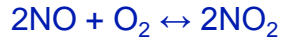

Step 3—Absorption of NO₂ (formation of HNO₃)

Nitrogen Dioxide from secondary oxidation chamber is introduced into a special absorption tower. NO₂ gas passed through the tower and water is showered over it. By the absorption, Nitric Acid is obtained.



Nitric acid so obtained is very dilute. It is recycled in absorption tower so that more and more NO₂ get absorbed. HNO₃ after recycle becomes about 68 per cent concentrated.

Manufacture of Ammonia, Nitric Acid, Urea and Ammonium Nitrate - *Nitric Acid*

Nitric Acid:

Step 4—Concentration

In order to increase the concentration of HNO_3 , vapours of HNO_3 are passed over concentrated H_2SO_4 . Being a dehydrating agent, H_2SO_4 absorbs water from HNO_3 and concentrated HNO_3 is obtained.

NITRIC ACID PROCESS

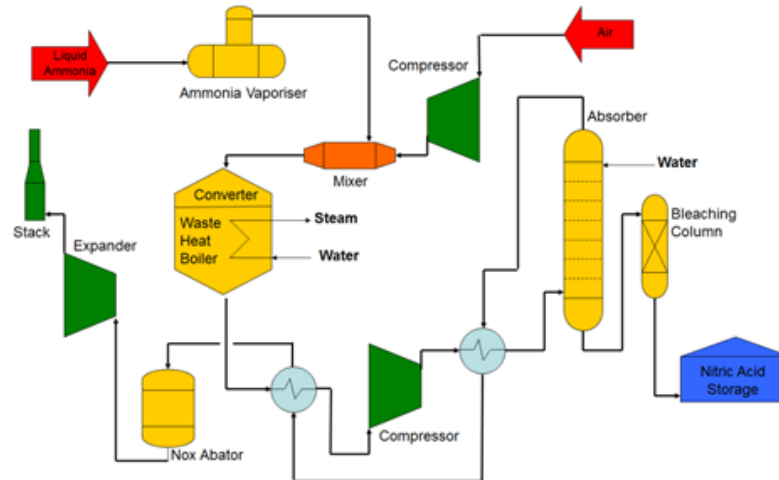

Manufacture of Ammonia, Nitric Acid, Urea and Ammonium Nitrate - *Ammonium Nitrate*

The industrial production of ammonium nitrate entails the acid-base reaction of ammonia with nitric acid:

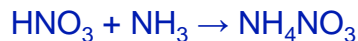

Ammonia is used in its anhydrous form (i.e., gas form) and the Nitric Acid is concentrated. This reaction is violent owing to its highly exothermic nature. After the solution is formed, typically at about 83% concentration, the excess water is evaporated to an Ammonium Nitrate (AN) content of 95% to 99.9% concentration (AN melt), depending on grade. The AN melt is then made into "prills" or small beads in a spray tower, or into granules by spraying and tumbling in a rotating drum. The prills or granules may be further dried, cooled, and then coated to prevent caking. These prills or granules are the typical AN products in commerce.

The Ammonia required for this process is obtained by the Haber process from Nitrogen and Hydrogen. Ammonia produced by the Haber process is oxidized to Nitric Acid by the Ostwald process. Another production method is a variant of the Odda process:



The products, Calcium Carbonate and Ammonium Nitrate, may be separately purified or sold combined as Calcium Ammonium Nitrate.

Manufacture of Ammonia, Nitric Acid, Urea and Ammonium Nitrate - *Ammonium Nitrate*

Ammonium Nitrate can also be made via Metathesis reactions:

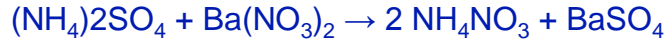

Note :

- Barium is a chemical element with symbol Ba,
- Barium Nitrate with chemical formula $Ba(NO_3)_2$ is a salt composed of Barium and the Nitrate ion,
- Barium Sulphate is the inorganic compound with the chemical formula $BaSO_4$,
- Silver is a chemical element with symbol Ag,
- Silver Nitrate is an inorganic compound with chemical formula $AgNO_3$,
- Silver Chloride is a chemical compound with the chemical formula $AgCl$.

AMMONIUM NITRATE PROCESS – WET SECTION

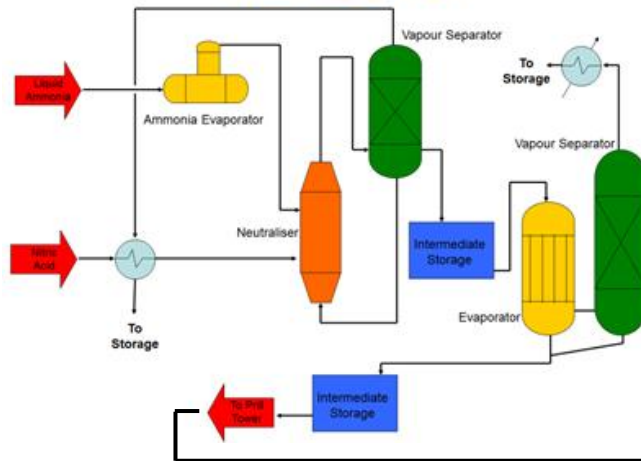

AMMONIUM NITRATE PROCESS – DRY SECTION

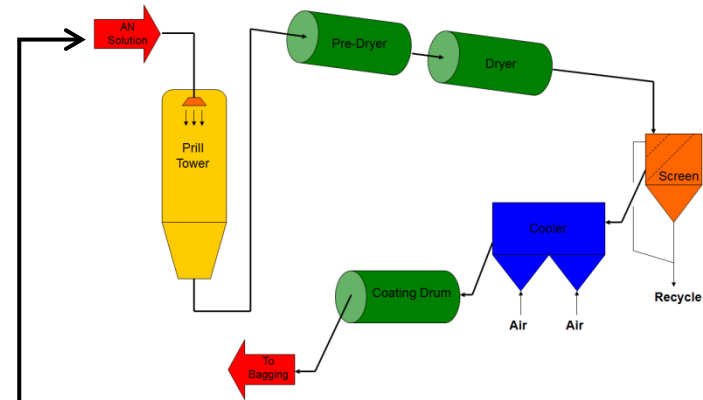

Coal – There Is A Lot More Too It



10/01/13

THE NEW AGE OF COAL

Transformative Power Plant

Black Coal – A Clean Future with a focus on Electricity Generation

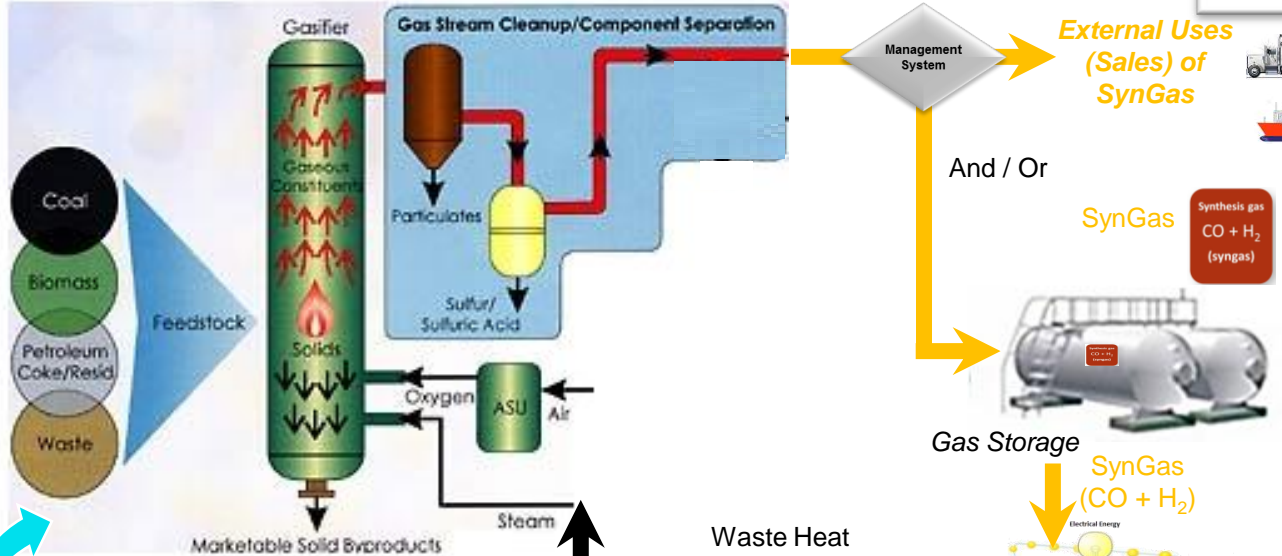
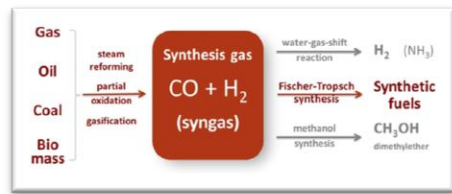

Note : With the Gasification / Fuel Cell approach pure CO₂ is a by-product which is produced without further Capture needed. In addition, the Fuel cell approach offers very high Efficiencies (≈ 60% +) therefore the Greenhouse Gas Intensity (tCO₂e / MWh) would be much lower.

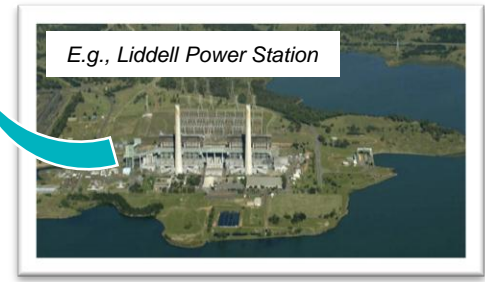

Transitioning the Liddell site into a new Clean Future

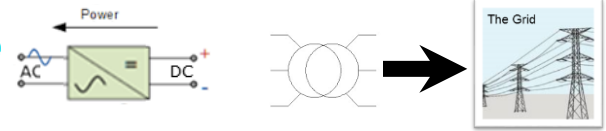
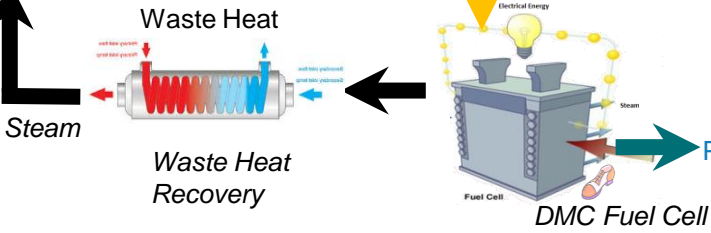

Transformative Power Plant

Black Coal and the Hydrogen Economy

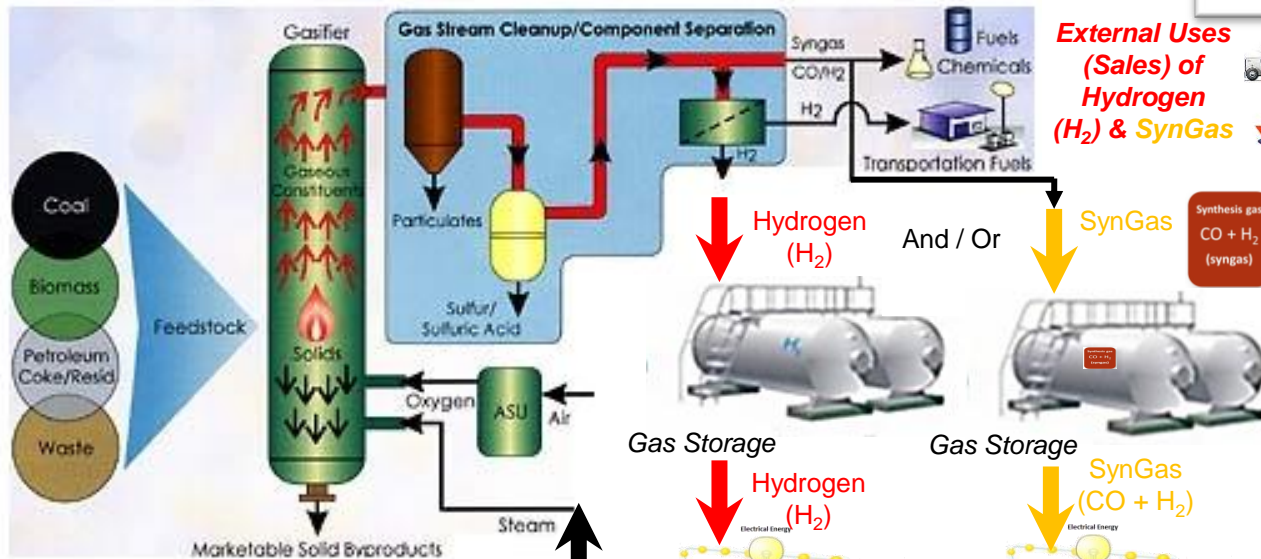
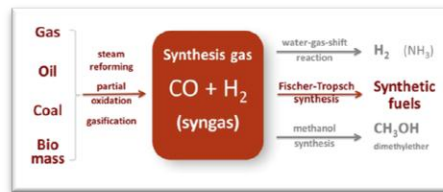

The Hydrogen Economy

Note : With the Gasification / Fuel Cell approach pure CO₂ is a by-product which is produced without further Capture needed. In addition, the Fuel cell approach offers very high Efficiencies(≈ 60% +) therefore the Greenhouse Gas Intensity (tCO₂e / MWh) would be much lower.

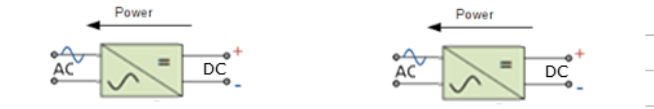
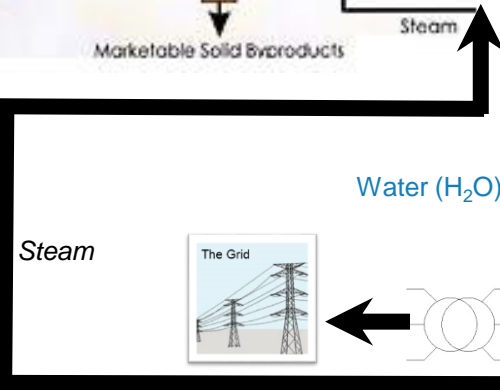
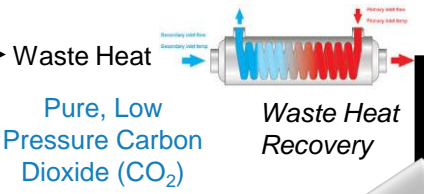
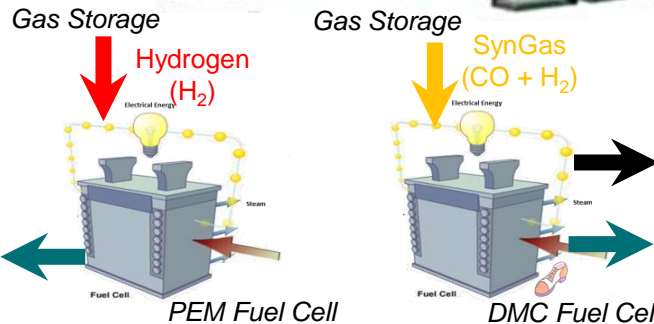

“The Transformative Power Plant”

Fuel Cell Technologies

There are a number Fuel Cell technologies however, in terms of Grid scale potential there are three technologies that are most suited and they are :

1. Proton Exchange Membrane (PEM),
2. Molten Carbonate Fuel Cell (MCFC),
3. Solid Oxide Fuel Cell (SOFC).

Fuel Cell Type
Alkaline (AFC)
Phosphoric Acid (PAFC)
Polymer Electrolyte Membrane or Proton Exchange Membrane (PEM)*
Molten Carbonate (MCFC)
Solid Oxide (SOFC)

Fuel Cell Technologies

Fuel Cell Type		Electrolyte	Operating Temperature	Electrical Efficiency	Fuel Oxidant	Energy Output
AFC	Alkaline Fuel Cell	Potassium hydroxide solution	Room temperature to 90°C	60-to-70%	H ²	300W-to-5KW
PEMFC	Proton Exchange Membrane Fuel Cell	Proton Exchange Membrane	Room temperature to 80°C	50-to-60% electric	H ²	1KW
DMFC	Direct Methanol Fuel Cell	Proton Exchange Membrane	Room temperature to 130°C		CH ³ OH , ...	1KW
PAFC	Phosphoric Acid Fuel Cell	Phosphoric Acid	160-to-220°C	55%	Natural gas, bio gas,	200KW
MCFC	Molten Carbonate Fuel Cell	Molten mixture of alkali metal carbonates	6200-to-660°C	85% overall with CHP (60% electric)	Natural Gas, Biogas, SynGas	2MW-to-100MW
SOFC	Solid Oxide Fuel Cell	Oxide ion conducting ceramic	800-to-1000°C		60-to-65%	Natural gas, bio gas, coal gas,

Source: h-tec, SAE International

Fuel Cell Operating Principles - PEM

Proton Exchange Membrane (PEM) Fuel Cells

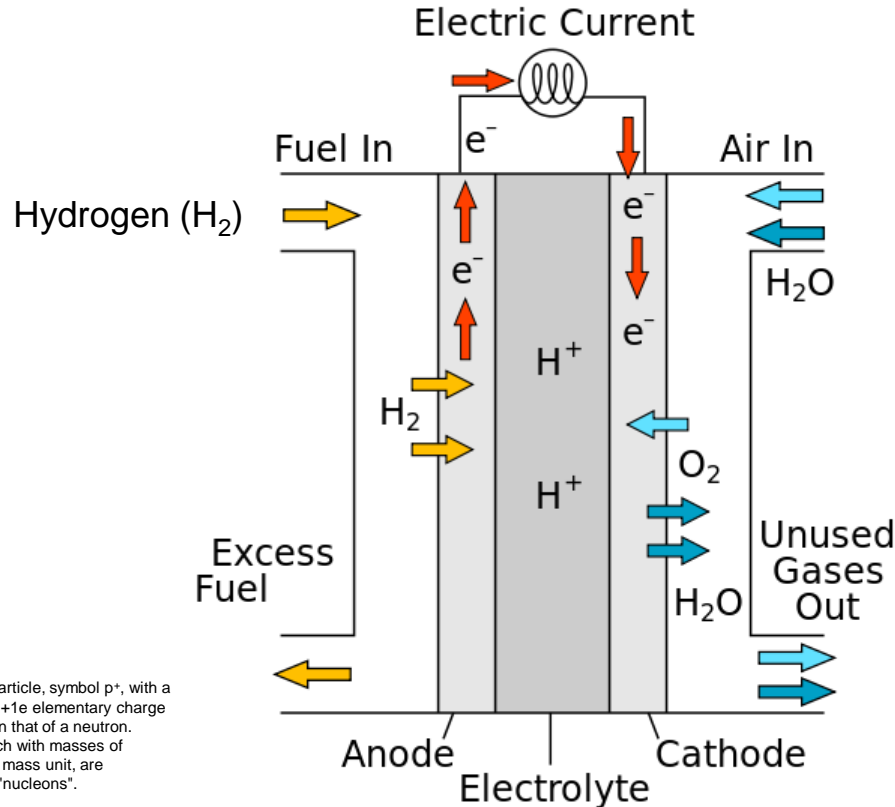

A Proton Exchange Membrane (PEM) Fuel Cell consists of a Proton-conducting Polymer Membrane (typically Nafion) that separates the Anode and Cathode sides. On the Anode side, Hydrogen (H₂) diffuses to the Anode Catalyst where it later dissociates into Protons and Electrons. These Protons often react with oxidants causing them to become what are commonly referred to as Multi-Facilitated Proton Membranes. The Protons are conducted through the Membrane to the Cathode, but the Electrons are forced to travel in an external circuit (supplying power) because the Membrane is electrically insulating. On the Cathode catalyst, Oxygen (O) molecules react with the Electrons (which have travelled through the external circuit) and Protons to form Water (H₂O).

A Proton is a subatomic particle, symbol p⁺, with a positive electric charge of +1e elementary charge and mass slightly less than that of a neutron. Protons and neutrons, each with masses of approximately one atomic mass unit, are collectively referred to as "nucleons".

Fuel Cell Operating Principles - PEM

Covalent Bonding occurs when pairs of electrons are shared by atoms. Atoms will Covalently Bond with other atoms in order to gain more stability, which is gained by forming a full Electron Shell. By sharing their outer most (valence) electrons, atoms can fill up their outer electron shell and gain stability.

Hydrogen atoms have 1 Electron in their outer Shell (they only have 1 Shell). Each Shell can contain only a fixed number of electrons: The first shell can hold up to two electrons, the second shell can hold up to eight (2 + 6) electrons and so on.

Two *hydrogen atoms* share an electron each so they've got two electrons between them and thus we get H₂ as a stable form of Hydrogen.

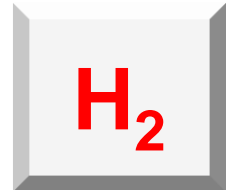
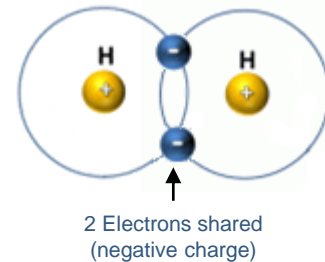
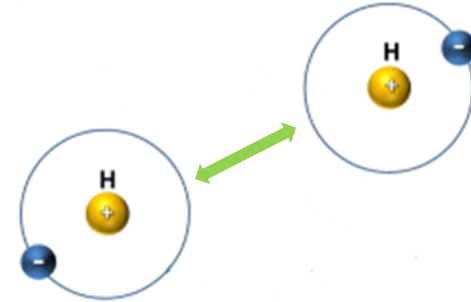
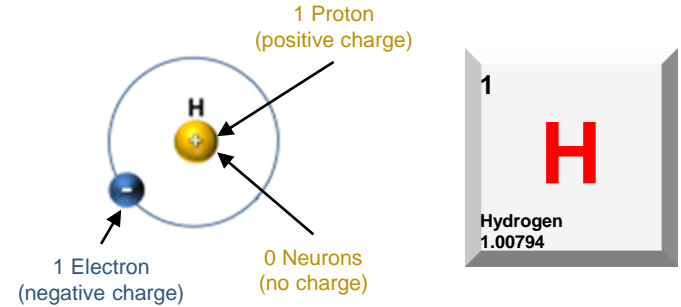

Fuel Cell Operating Principles - PEM

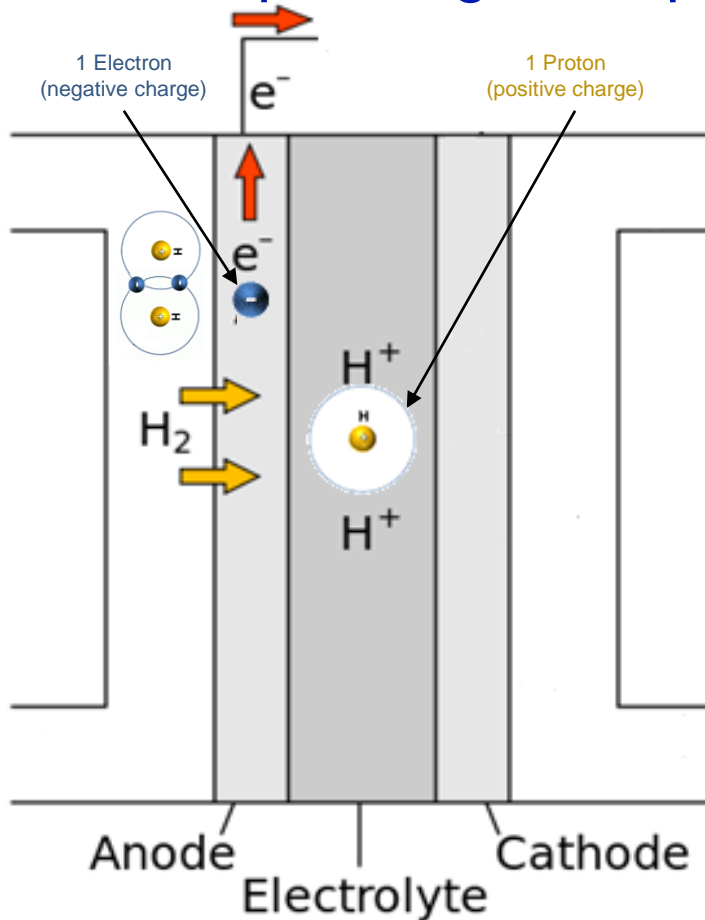

On the Anode side, Hydrogen (H_2) diffuses to the Anode Catalyst where it later dissociates into Protons and Electrons. These Protons often react with oxidants causing them to become what are commonly referred to as Multi-Facilitated Proton Membranes. The Protons are conducted through the Membrane to the Cathode, but the Electrons are forced to travel in an external circuit (supplying power) because the Membrane is electrically insulating.

Fuel Cell Operating Principles - PEM

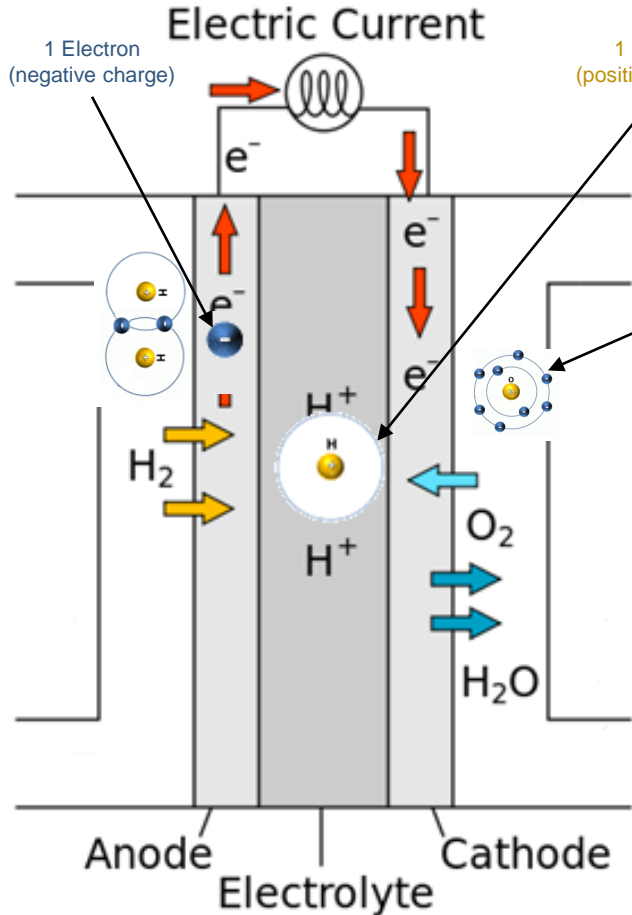

2x

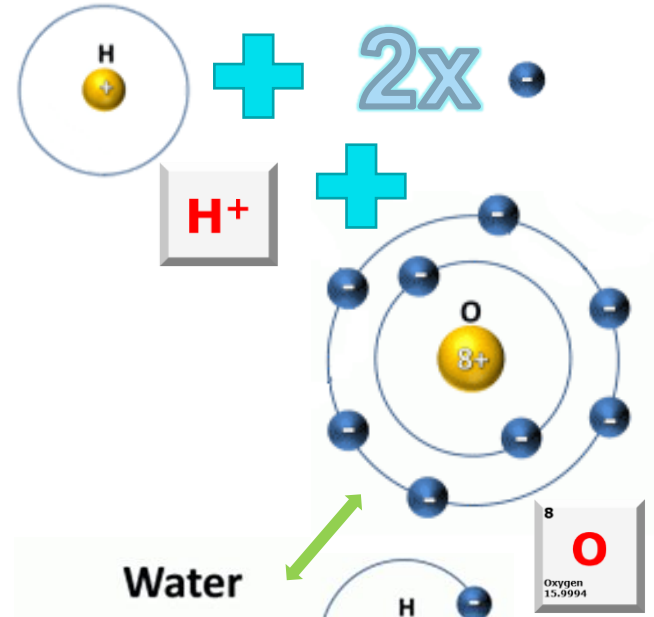

8 Electrons +
8 Protons + 8 Neutrons
(neutral charge)

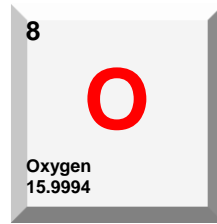

On the Cathode catalyst, Oxygen (O), molecules react with the Electrons (which have travelled through the external circuit) and Protons to form Water (H_2O).

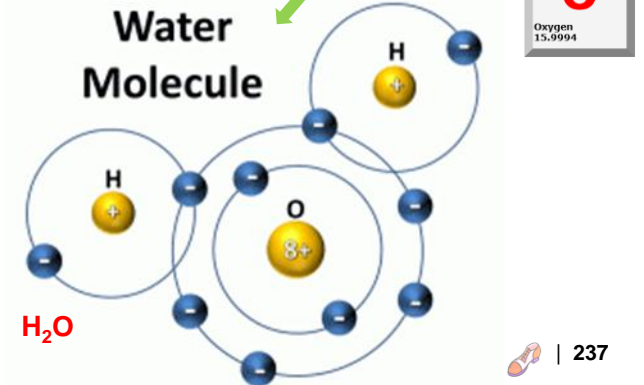

Fuel Cell Operating Principles - MCFC

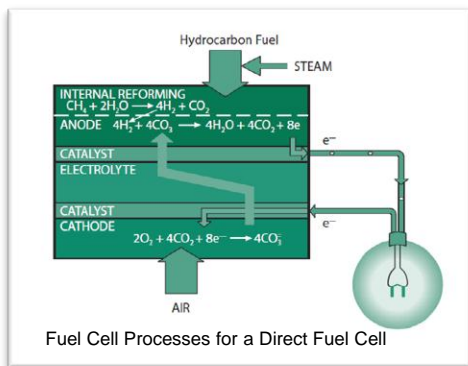
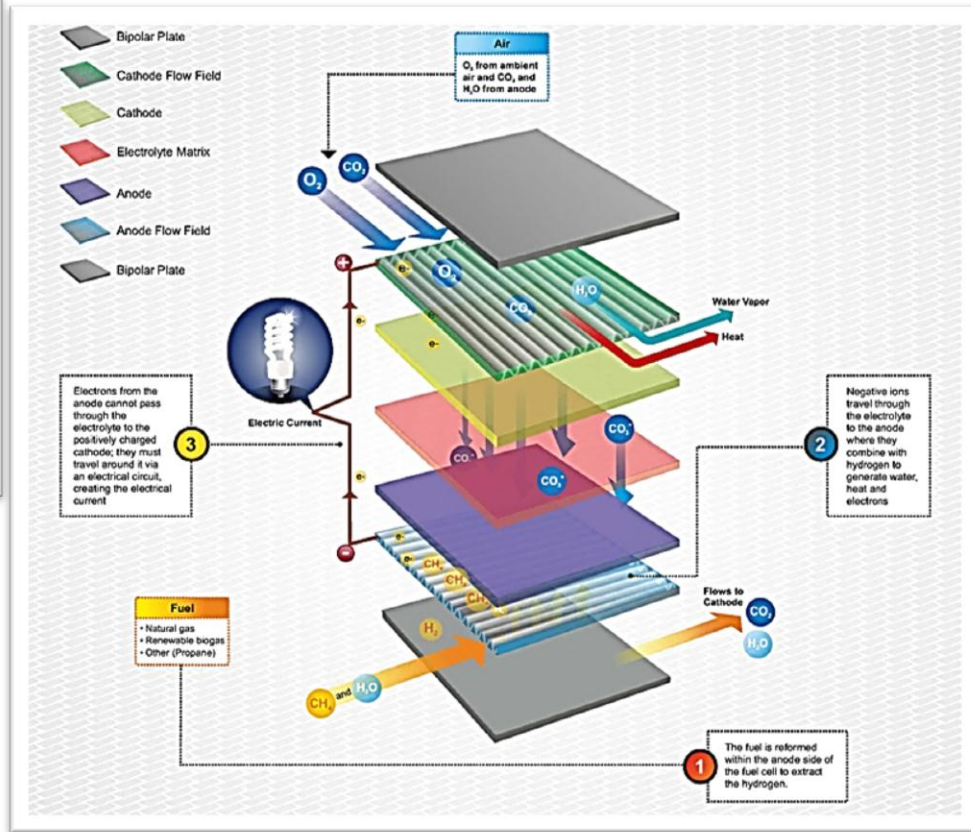

“The Transformative Power Plant”

Hydrogen Economy

The Hydrogen Economy



Hydrogen is a Possible Key to a Secure and Clean Energy Future

Energy Security

Produced from a variety of domestic sources

Environmental

Criteria pollutants from mobile sources eliminated

Emissions from stationary H₂ production sites easier to control

Greenhouse gas emissions significantly reduced

Economic Competitiveness

Abundant, reliable, and affordable energy is an essential component in a healthy, global economy

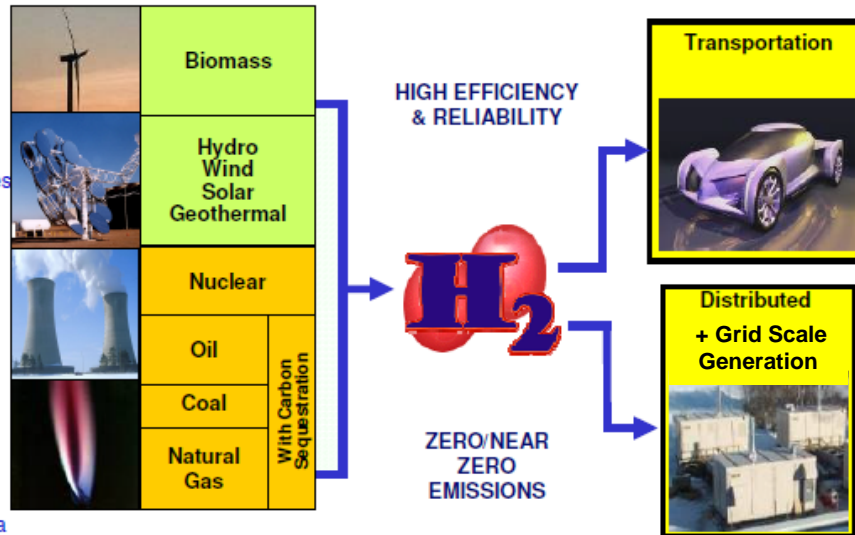

The Hydrogen Economy

TheNational

Hydrogen is the energy of the future for Japan

By : Richard Smith, Foreign Correspondent
May 16, 2016 Updated: May 16, 2016 01:54 PM

TOKYO : To become reality, Tokyo's dream to have approaching 1 million hydrogen fuel-cell vehicles on Japan's streets in 15 years time will require huge investment and major government support, analysts say.

A March report by Japan's ministry of economy, trade and industry projects putting 40,000 hydrogen fuel-cell cars on the country's roads by 2020, with a 20-fold expansion to 800,000 by 2030. Currently, about 400 such vehicles operate in Japan, the report says.

The report also outlines plans to double the number of hydrogen fuelling stations to about 160 by the end of the current fiscal year next March, doubling it again to 320 over the following five years.

Prime Minister Shinzo Abe has called hydrogen "the energy of the future," one that would allow Japan to diversify energy sources and cut carbon dioxide emissions.

...



The Hydrogen Economy

**SCIENTIFIC
AMERICAN**

Japan Bets on a Hydrogen-Fueled Future The auto-making country hopes to craft a transportation future powered by fuel cells

By Umair Irfan, on May 3, 2016

Japan is betting big on hydrogen and wants the rest of the world to join in.

In March, the country's Ministry of Economy, Trade and Industry set a target of 40,000 hydrogen fuel-cell vehicles on its roads by 2020 and 160 fueling stations, up from the 80 hydrogen stations operating right now. The agency also set an 800,000 yen (\$8,000) price target for household polymer electrolyte fuel cells by 2019.

The private sector is chipping in, as well. Japanese auto giant Toyota released the Mirai, the company's first commercial fuel-cell-powered car, in 2014. Fuel cells turn hydrogen gas into electricity, which in turn drives an electric motor.

Earlier this year, Kawasaki Heavy Industries Ltd. and Iwatani Corp. partnered with Kobe city to build a 10 billion yen (\$84 million) liquefied hydrogen import hub. The project, due to go online in 2020, will import hydrogen made from lignite coal in Australia.

The hydrogen push is a strategic and practical bet for a resource-strapped island nation. Though nations like China are investing heavily in batteries for vehicles and on the grid, hydrogen has some promising economic and environmental advantages for Japan.

"Hydrogen is attracting attention as an energy source that can solve problems such as global warming and depletion of energy resources," said Kazuo Furukawa, chairman of the New Energy and Industrial Technology Development Organization (NEDO). "Abundant. Clean. Flexible."

The Hydrogen Economy

**SCIENTIFIC
AMERICAN**

Japan Bets on a Hydrogen-Fueled Future The auto-making country hopes to craft a transportation future powered by fuel cells

By Umair Irfan, on May 3, 2016

He spoke last month at the Woodrow Wilson International Center for Scholars in Washington, D.C., to outline the case for creating a “hydrogen society.”

“A hydrogen society is where hydrogen is readily available for us,” Furukawa said. In addition to fueling cars, hydrogen could provide household backup power and store excess wind and solar power on the grid.

GETTING A HEAD START?

But this would require cheap sources of hydrogen, whether it’s electrolyzing water with renewable energy or gasifying lignite coal. The system would demand pipelines and shipping methods to transport hydrogen and then fueling stations to distribute it to end users like cars, households and industries. Driving the costs of this infrastructure down far enough to compete with fossil fuels would depend on a global economy of scale, and many countries would have to buy in.

“For this reason, cooperation with other countries is very important,” Furukawa said. “Global warming cannot be fixed by any one country.” The economic upside for Japan may be substantial, as well, as the country struggles with a national debt that has ballooned to 240 percent of its gross domestic product.

The Hydrogen Economy

**SCIENTIFIC
AMERICAN**

Japan Bets on a Hydrogen-Fueled Future The auto-making country hopes to craft a transportation future powered by fuel cells

By Umair Irfan, on May 3, 2016

“There is an incentive for nations to have a unique, differentiated approach and push the rest of the world to adopt,” said Cosmin Laslau, a senior analyst at Lux Research, a market analysis firm. For Japan, moving early and aggressively in hydrogen could give its industries an edge as the world plays catch-up.

“These companies are world-class, and if they put their weight behind the technology, that has a very positive impact on growth,” Laslau added.

POLICIES, INCENTIVES PLAY KEY ROLE

Though fuel cells have made tremendous strides in driving down costs, using fewer precious metal catalysts and more efficient components, fuel-cell-powered cars still have a higher entry price tag. The Toyota Mirai starts at \$57,000, while Nissan’s all-electric Leaf starts at \$29,000.

The upsides of longer range and faster fueling may not be enough to bridge the price gap for early adopters, Laslau observed. And while improved technology can fill part of the price gap, the remainder depends on manufacturers and suppliers following Japan’s lead, building up supply chains to support fuel cells on an international scale.

“If [manufacturers] were able to scale up and sell a million vehicles, the price would come way, way down,” said Christopher San Marchi, manager of the hydrogen program at Sandia National Laboratories. “We have not started reaching economies of scale yet.”

The Hydrogen Economy

**SCIENTIFIC
AMERICAN**

Japan Bets on a Hydrogen-Fueled Future

The auto-making country hopes to craft a transportation future powered by fuel cells

By Umair Irfan, on May 3, 2016

Governments can speed up the process through targets, incentives and regulations, San Marchi observed, noting that states like California also have mandates for zero-carbon-emissions vehicles that include fuel cells.

Policies can also help resolve the chicken-or-the-egg dilemma of whether building hydrogen fueling stations will convince more people to buy fuel-cell-powered cars or vice versa.

Nonetheless, both batteries and hydrogen fuel cells may find niches in vehicles and on the power grid over the coming years. “It’s not an either-or,” he said “They’re complementary in many ways.”



Toyota *Mirai* – Hydrogen Fuel Car

Hydrogen Safety

ZERO EMISSIONS. ZERO COMPROMISE

HYDROGEN SYSTEMS ARE SAFE

Hydrogen systems are as safe, if not safer, than conventional fuel systems, including gasoline and natural gas. Hydrogen is ubiquitous in the universe. On Earth, hydrogen is a molecule consisting of two atoms and has a propensity to bond with other molecules.

Hydrogen has been safely used by many different industrial sectors for more than 50 years. Ten million metric tons of hydrogen is produced every year for use in a range of industrial applications such as chemical, refining, electronics, and pharmaceuticals. Hydrogen can create clean energy and stores energy from renewables, is used to make fertilizer, and makes consumer goods and food more shelf-stable.

In the transportation section, hydrogen has been safely used as a fuel for cars, trucks, buses, forklifts, and other applications. In fact, FCVs meet the strictest safety and quality standards set by both the United States National Highway and Transportation Administration (NHTSA) and the United Nations Global Technical Regulations (GTR).

On the next page are six facts demonstrating hydrogen's unique safety qualities.



Hydrogen has been safely produced, stored, transported, and used in the American industrial sector for the past 50 years.



FCVs meet the National Highway Safety Transportation Administration's strictest safety and quality standards.



1 | LOW RADIANT HEAT

Hydrogen flames have low radiant heat. Hydrogen combustion produces heat and water. Due to the absence of carbon, a hydrogen flame has significantly less radiant heat compared to a hydrocarbon fire. Since the flame emits low levels of radiant heat and takes (the flame itself is just as hot) the risk of secondary fires is lower.

2 | NEEDS OXYDIZER TO COMBUST

Combustion cannot occur in a tank unless both a fuel (hydrogen) and an oxidizer are present. This means an oxidizer, such as air, must be present in the hydrogen tank or systems. Due to the physical properties of hydrogen and hydrogen storage system design, it is impossible to get air in a tank under normal conditions.

3 | CARBON-FIBER TANKS

FCV car manufacturers have developed and tested carbon-fiber hydrogen storage tanks, which withstand crash, drop test, fire, and ballistic testing.

4 | SAFETY SYSTEMS

Hydrogen tanks and the vehicle systems are designed with multiple safety enhancements to prevent leaks in both routine use and extreme circumstances. In the very unlikely scenario that an issue should occur, hydrogen systems are designed to safely release and ventilate the hydrogen.

5 | SAFE AND FAST HYDROGEN FUELING

The hydrogen fueling protocol has been universally accepted around the world to ensure safe refueling of fuel cell vehicles in three to five minutes for a range of 300 - 400 miles on a tank of fuel.

6 | SAFETY, CODES, AND STANDARDS

As a result of decades of fundamental research into hydrogen behavior by private sector companies, the U.S. Department of Energy, and other organizations around the world, we have learned how to make hydrogen systems as safe, if not safer, than conventional fueling systems such as gasoline, natural gas, propane, and others.

Hydrogen safety information resources and best practices are being developed and continually refined for emergency responders and authorities having jurisdiction based on safety research and development, as well as stakeholder input from the fire-protection community, academia, automobile manufacturers, and the energy, insurance, and aerospace sectors.

For further reading on hydrogen safety, we recommend the following resources:

The Hydrogen and Fuel Cell Safety Report maintained by the Fuel Cell and Hydrogen Energy Association: www.hydrogenandfuelcellsafety.info/

Hydrogen Tools Portal maintained by the Pacific Northwest National Laboratory (PNNL): <https://h2tools.org/>



The Fuel Cell and Hydrogen Energy Association (FCHEA) represents the leading companies and organizations that are advancing innovative, clean, safe, and reliable energy technologies. FCHEA drives support and provides a consistent industry voice to regulators and policymakers. Our educational efforts promote the environmental and economic benefits of fuel cell and hydrogen energy technologies.

For more information, please visit www.zeroemissions.org

Hydrogen Safety

facts

1.008

hydrogen SAFETY

Hydrogen: Similar but Different

For over 40 years, industry has used hydrogen in vast quantities as an industrial chemical and fuel for space exploration. During that time, industry has developed an infrastructure to produce, store, transport and utilize hydrogen safely.

"Hydrogen safety concerns are not cause for alarm; they simply are different than those we are accustomed to with gasoline or natural gas."

—Air Products and Chemicals, Inc.

Hydrogen is no more or less dangerous than other flammable fuels, including gasoline and natural gas. In fact, some of hydrogen's differences actually provide safety benefits compared to gasoline or other fuels.

However, all flammable fuels must be handled responsibly. Like gasoline and natural gas, hydrogen is flammable and can behave dangerously under specific conditions. Hydrogen can be handled safely when simple guidelines are observed and the user has an understanding of its behavior.

The following lists some of the most notable differences:

Hydrogen is lighter than air and diffuses rapidly. Hydrogen has a rapid diffusivity (3.8 times faster than natural gas), which means that when released, it dilutes quickly into a non-flammable concentration. Hydrogen rises 2.8 times faster than helium and 6 times faster than natural gas at a speed of almost 45 mph (20m/s). Therefore, unless a roof, a poorly ventilated room or some other structure contains the rising gas, the laws of physics prevent hydrogen from lingering near a leak (or near people using hydrogen-fueled equipment). Simply stated, to become a fire hazard, hydrogen must first be confined – but as the lightest element in the universe, confining hydrogen is very difficult. Industry takes these properties into account when designing structures where hydrogen will be used. The designs help hydrogen escape up and away from the user in case of an unexpected release.

Hydrogen is odorless, colorless and tasteless, so most human senses won't help to detect a leak. However, given hydrogen's tendency to rise quickly, a hydrogen leak indoors would briefly collect on the ceiling and eventually move towards the corners and away from where any nose might detect it. For that and other reasons, industry often uses hydrogen sensors to help detect hydrogen leaks and has maintained a high safety record using them for decades. By comparison, natural gas is also odorless, colorless and tasteless, but industry adds a sulfur-containing odorant, called mercaptan, to make it detectable by people. Currently, all known odorants contaminate fuel cells (a popular application for hydrogen). Researchers are investigating other

methods that might be used for hydrogen detection: tracers, new odorant technology, advanced sensors and others.

Hydrogen flames have low radiant heat. Hydrogen combustion primarily produces heat and water. Due to the absence of carbon and the presence of heat-absorbing water vapor created when hydrogen burns, a hydrogen fire has significantly less radiant heat compared to a hydrocarbon fire. Since the flame emits low levels of heat near the flame (the flame itself is just as hot), the risk of secondary fires is lower. This fact has a significant impact for the public and rescue workers.



Hydrocarbon flames (left, red arrow) vs. hydrogen flames (right, blue circle)

Combustion

Like any flammable fuel, hydrogen can combust. But hydrogen's buoyancy, diffusivity and small molecular size make it difficult to contain and create a combustible situation. In order for a hydrogen fire to occur, an adequate concentration of hydrogen, the presence of an ignition source and the right amount of oxidizer (like oxygen) must be present at the same time. Hydrogen has a wide flammability range (4-74% in air) and the energy required to ignite hydrogen (0.02mJ) can

Figure 1: Fuel Comparisons

	Hydrogen	Gasoline Vapor	Natural Gas
Flammability Limits (in air)	4-74%	1.4-7.6%	5.3-15%
Explosion Limits (in air)	18.3-59.0%	1.1-3.3%	5.7-14%
Ignition Energy (mJ)	0.02	0.20	0.29
Flame Temp. in air (°C)	2045	2197	1875
Stoichiometric Mixture (most easily ignited in air)	29%	2%	9%

be very low. However, at low concentrations (below 1%) the energy required to ignite hydrogen is high—similar to the energy required to ignite natural gas and gasoline in their respective flammability ranges—making hydrogen realistically more difficult to ignite near the lower flammability limit. On the other hand, if conditions exist where the hydrogen concentration increased toward the stoichiometric (most easily ignited) mixture of 29% hydrogen (in air), the ignition energy drops to about one-fifth that required to ignite natural gas (or one tenth for gasoline). See Figure 1 (page 1) for more comparisons.



Hydrogen car (l), gasoline car (r). Photo from a video that compares fires from an intentionally ignited hydrogen tank release to a small gasoline fuel line leak. At the time of this photo (60 seconds after ignition), the hydrogen flame has begun to subside, while the gasoline fire is intensifying. After 100 seconds, all of the hydrogen was gone and the car's interior was undamaged. (The maximum temperature inside the back window was only 67°F) The gasoline car continued to burn for several minutes and was completely destroyed. Photo/Text: Dr. Swain, University of Miami.

Hydrogen Economy ≠ Hydrogen Bomb

The hydrogen economy uses the most common type of hydrogen: the isotope, Protium. Hydrogen bomb technology uses a rare hydrogen isotope called Tritium. Both Tritium plus the super-intense heat from the detonation of a nuclear fission bomb are needed to induce the nuclear fusion reaction that makes a hydrogen bomb. Tritium is radioactive and does not occur naturally, but can be made with lithium or a conventional nuclear reactor. This technology bears no resemblance to the simple chemical reactions associated with the Protium hydrogen isotope in hydrogen production, storage, distribution and use in the hydrogen economy.

likelihood that hydrogen will explode in open air due to its tendency to rise quickly. This is the opposite of what we find for heavier gases such as propane or gasoline fumes, which hover near the ground, creating a greater danger for explosion.

Asphyxiation

With the exception of oxygen, any gas can cause asphyxiation. In most scenarios, hydrogen's buoyancy and diffusivity make hydrogen unlikely to be confined where asphyxiation might occur.

Toxicity/poison

Hydrogen is non-toxic and non-poisonous. It will not contaminate

groundwater (it's a gas under normal atmospheric conditions), nor will a release of hydrogen contribute to atmospheric pollution. Hydrogen does not create "fumes."

Cryogenic burns

Any cryogenic liquid (hydrogen becomes a liquid below -423°F) can cause severe freeze burns if the liquid comes into contact with the skin. However, to keep hydrogen ultra-cold today, liquid hydrogen containers are double-walled, vacuum-jacketed, super-insulated containers that are designed to vent hydrogen safely in gaseous form if a breach of either the outer or inner wall is detected. This robust construction and redundant safety features dramatically reduce the likelihood for human contact.

"Don't paint your airship with rocket fuel!"



The fire that destroyed the Hindenburg in 1937 gave hydrogen a misleading reputation. Hydrogen was used to keep the airship buoyant and was initially blamed for the disaster. An investigation by Addison Bain in the 1990s provided evidence that the airship's fabric envelope was coated with reactive chemicals, similar to solid rocket fuel, and was easily ignitable by an electrical discharge. The Zeppelin Company, builder of the Hindenburg, has since confirmed that the flammable, doped outer cover is to be blamed for the fire. For more information, view a short video at: www.HydrogenAssociation.org

Hydrogen Codes and Standards

Codes and standards help dictate safe building and installation practices. Today, hydrogen components must follow strict guidelines and undergo third party testing for safety and structural integrity. For more information on hydrogen safety, codes and standards, please visit the following websites:

www.HydrogenSafety.org
www.fuelcellstandards.com
www.eere.energy.gov/hydrogenandfuelcells/codes

Summary

Industry has developed new safety designs and equipment because hydrogen's properties and behavior are different than the fuels we use now. Hydrogen will make us re-think operating practices already in place for gaseous and liquid fuels. Education of those differences is the key enabler to making hydrogen a consumer-handled fuel that we use safely and responsibly.



Hydrogen Safety - Standards

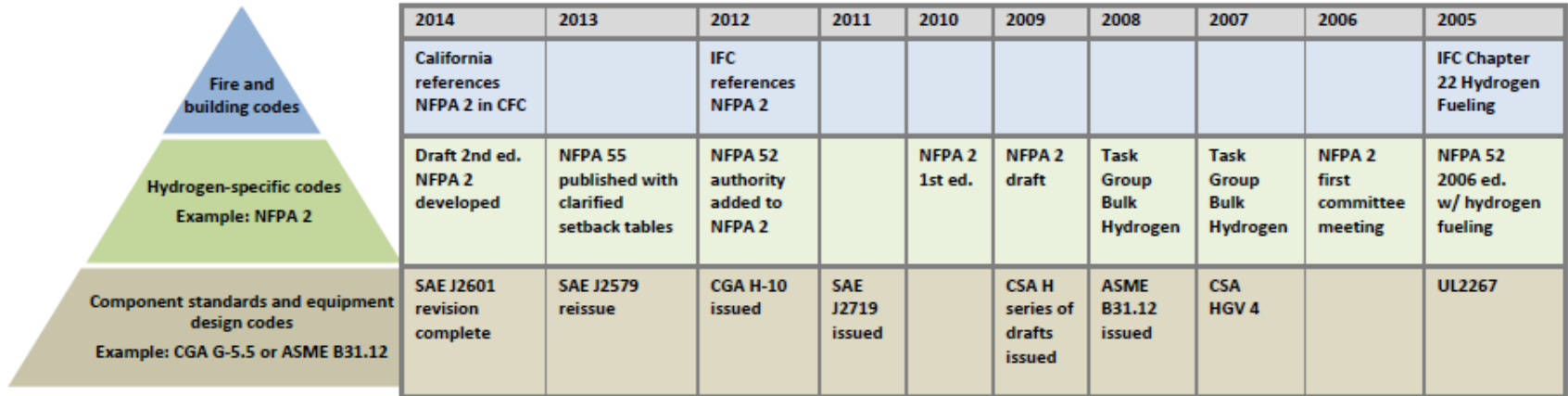

Timeline of codes and standards development and the codes and standards hierarchy

“Spark Spread” For Various NG Fuel Technologies

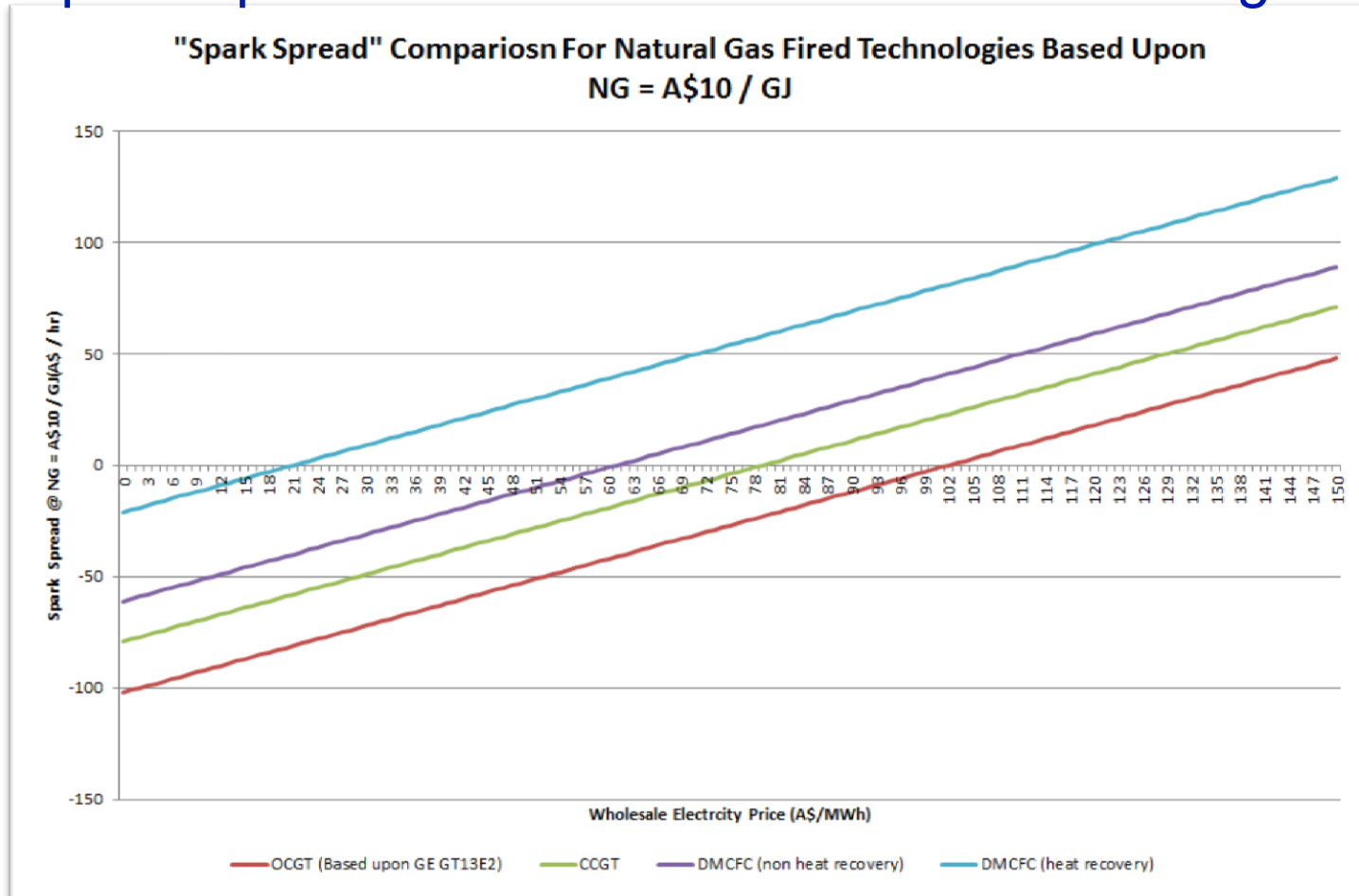

Contact :

**Jeffrey Jamieson
Minserve**



Telephone : (07) 3377 6777

Mobile : 0419 303 531

E-mail :

jeffjamieson@minserves.com.au

Author :

Glenn “Shoey” Schumacher

BEng.(Mech.), Grad. Cert. Man.(Human Resources), MBA.(Tech. Man.), MEng.(Power Gen.), DEng.
(*honourous causa*), FIEAust., CPEng., NER., RPEQ, AFAIM, FAIE, MAusIMM, MAMC, ASME.

MM Technology



**“The best way to predict your
future is to create it!”**

Abraham Lincoln – February 1809 to April 1865, 16th U.S. President.





The Author

Glenn (Shoey) Schumacher, holds a Bachelor Engineering – Mechanical (UTS), Master of Engineering – Power Generation (UQ), Master of Business Administration (Deakin), Graduate Certificate of Human Resource Management (USQ), Doctor of Engineering [*Honorius Causa*] (CQU).

Shoey is a Fellow of the Institute of Engineers Australia, a Chartered Professional Engineer, a NPER3 Registered Engineer, a Registered Professional Engineer - Queensland, a Member of the College of Mechanical Engineering, a Fellow of the Institute of Energy Australia, a Member of the Australian Institute of Mining and Metallurgy and an Associate Fellow of the Australian Institute of Management.

Shoey served as AGL Energy Ltd.'s Chief Engineer from November 2013 to September 2017. In that period AGL doubled its Generating capacity to over 10,000 MW and covered technologies such as Brown and Black Coal Fired Plant, Brown Coal Mining, Open Cycle Gas Turbines, Hydro, Gas Fired Boilers, Wind and Grid Scale PV Solar along with developments around Grid Scale Storage technologies. Shoey was heavily involved in the Technical Due Diligence undertaken by AGL into the acquisition of the then Macquarie Generation and then lead the AGL Macquarie Operations Integration Team after acquisition.

Previously Shoey was the General Manager of NRG Gladstone Power Station (Queensland's largest power station) for six years. He has held a number of roles in not only the power industry but also across a number of heavy industries and manufacturing in locations from Burnie, Tasmania to Gladstone, Queensland. Those roles have included the fields of maintenance, production and engineering/technical services. Shoey has a particular passion and interest in milling (pulverising) plant and processes.

