



VELUX®

Commercial

VELUX Modular Skylights

Daylight solutions for public and commercial buildings



Version 5.1

veluxcommercial.com



Front cover: Genmab, Research Facility of Biotechnology, Utrecht, The Netherlands

Above: Atrium Longlight in DSV Headquarters, Hedeusene, Denmark

Advanced, innovative and proven

When you've developed a product with potential to change the way rooflights are designed, specified, installed and operated for years to come, you're bound to use bold descriptors, such as the three keywords above. As we've begun to describe just how special our rooflights are, though, it's become abundantly clear that they more than live up to these descriptors.

When VELUX modular skylights were first introduced in 2011, they were the first prefabricated rooflights, incorporating high energy performance, thermal stability and great strength in a slim and fully integrated design. Since then, our modular skylight systems have established themselves as the most innovative on the market and are now the proven choice in commercial buildings throughout Europe.



“ This is our contribution in terms of pushing the prefabrication of sophisticated building elements forward.

Paul Kalkhoven
Senior partner at Fosters + Partners



Atrium Longlight, Wiebengacomplex,
Groningen, The Netherlands.



Ridgelights in De Assenburg Shopping Mall,
Bimmel, The Netherlands.

Index

VELUX Modular Skylights	6
One-step approach to daylight, ventilation and indoor comfort	8
Unique features for great daylight design	9
Advanced daylight and heat control	10
Several intelligent control options	11
Modularity	12
The Module	14
The System	15
The Solutions	16
Functions	18
One size fits all	19
How to measure the modules	20
Size grid	21
Material, Colours and Design	22
Interior	24
Exteriors	26
Case Studies	28
Longlight 5 – 30°	30
Wall-mounted Longlight 5 – 45°	33
Northlight 25 – 90°	34
Ridgelight 25 – 40°	36
Ridgelight at 5° with Beams	38
Atrium Longlight/Ridgelight	40
Performance	44
Glazing and U-values	46
Classifications	50
Certifications	56
Additional Products	60
Sun screening – Roller blinds	62
Sun screening – External awning blinds	63
Photovoltaic glazing	64
Sun screening – Electrochrome glass	65
Infill panel	65
Smoke ventilation and wind deflector	66
Installation	68
Installation	70
Support	72
Technical drawings, 2D	74
CAD/BIM objects, 3D	75
Sub-construction	76
VELUX Daylight Visualizer	77
Support and contact	78

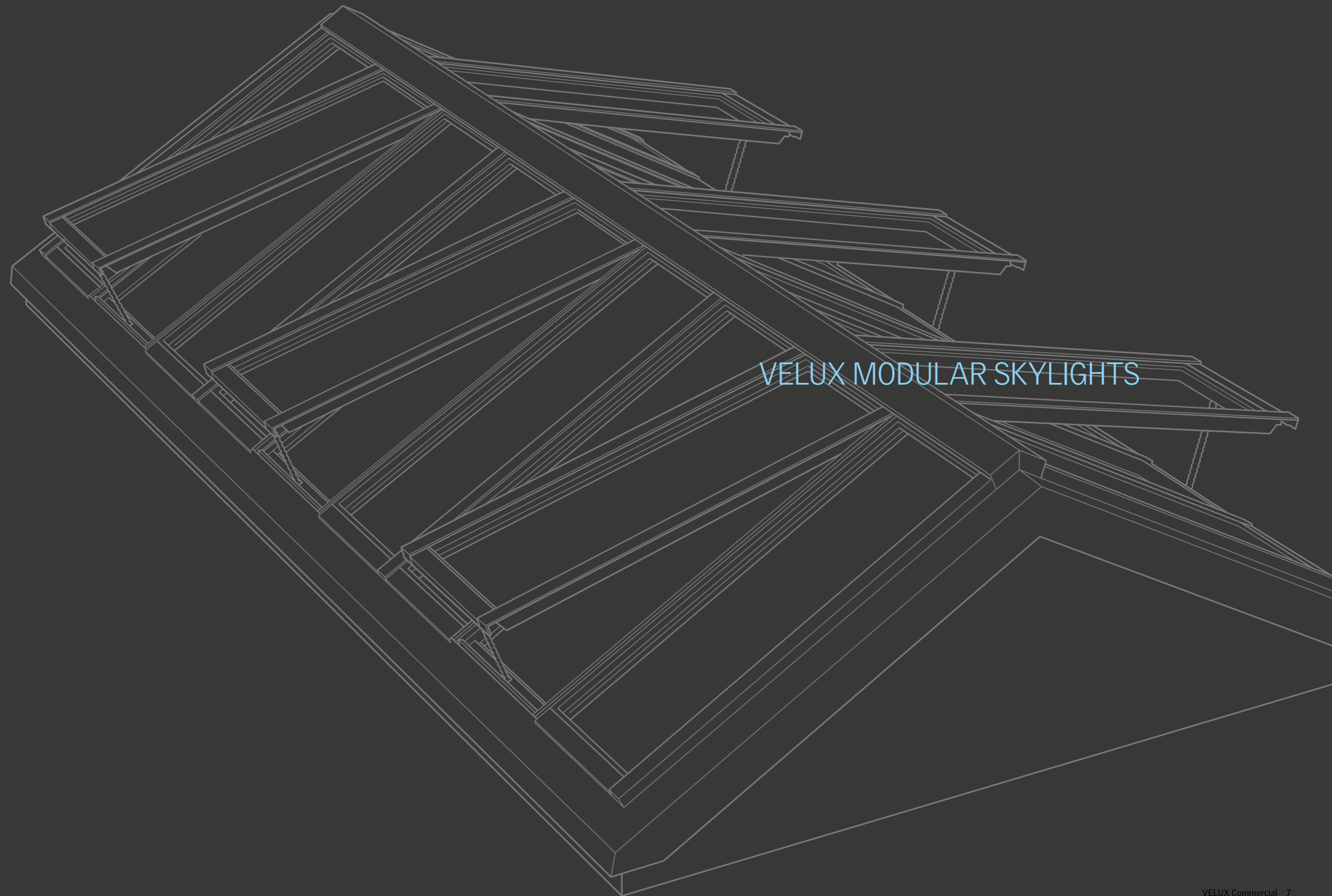

VELUX MODULAR SKYLIGHTS

A one-step approach to daylight, ventilation and indoor comfort



Somfy Lighthouse, Verrière-Somfy, France

Daylight solutions for sustainable buildings

Understanding how the indoor climate impacts health and comfort is vital to new building design, as well as, renovation projects. The modular features of our rooflights make it possible to achieve the best product classifications.

Unique features for great daylight design

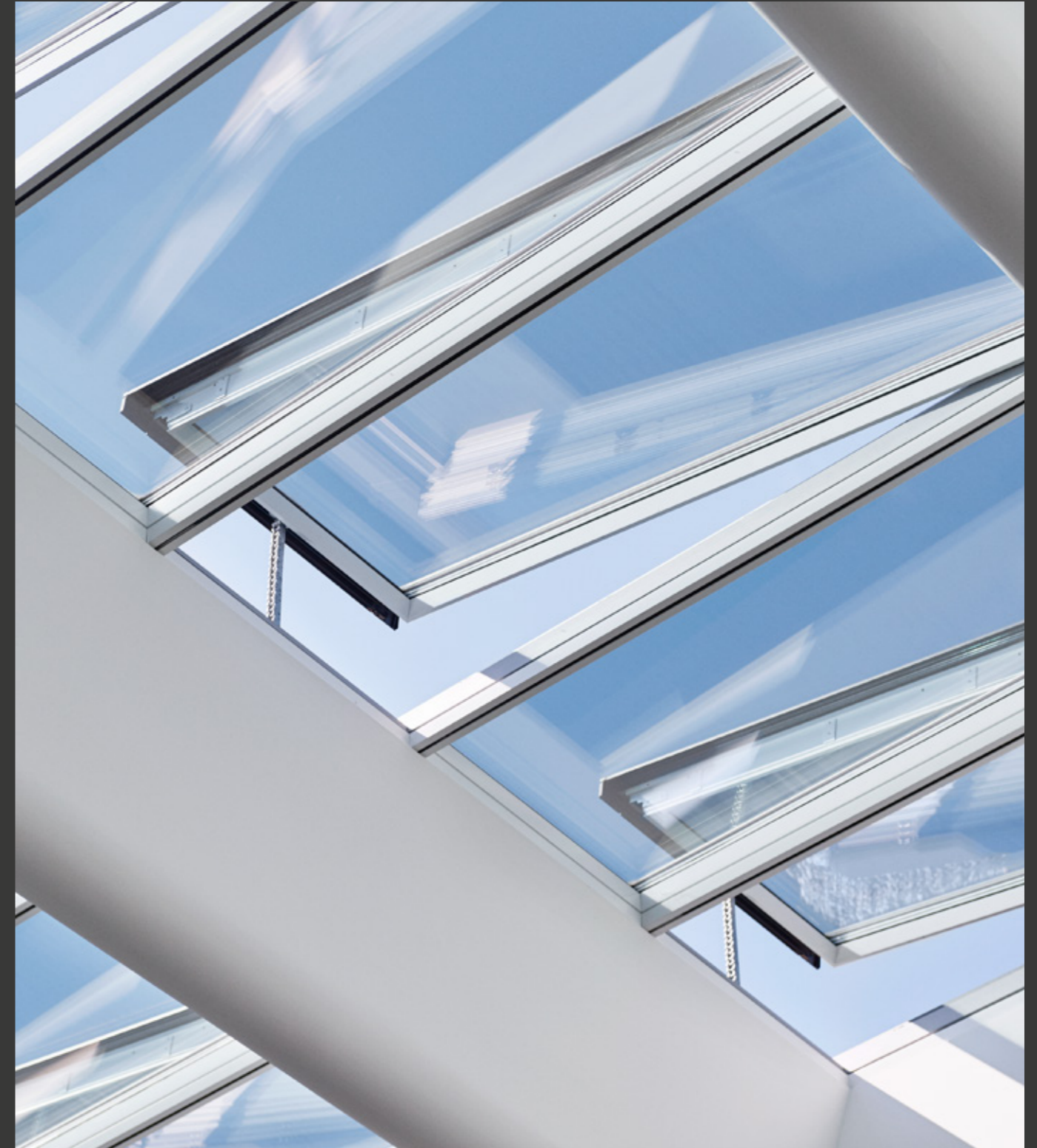

German Center for Neurodegenerative Diseases (DZNE), Bonn, Germany

Quite simple with a curved and slim design

Venting modules are fitted with a fully integrated chain actuator that allows automatic ventilation in the room. The actuator can be connected to an intelligent control system that closes the module automatically

in case of rain or strong winds. In the closed position, there's no visual difference between fixed and venting modules.

Integrated sun screening to control glare and heat



Siemens Head Office, Ballerup, Denmark

Advanced daylight and heat control with integrated roller blinds

Specially-designed roller blinds (optional) protect against solar glare and excessive heating. The fully-integrated blinds employ thin wires to hover beneath the

pane, creating the sensation of a free-floating window shade. Blinds are automatic and can be programmed to respond to luminosity and temperature.

VELUX INTEGRA® or Open System



ATP Huset, Vordingborg, Denmark

Choose between several intelligent control options

VELUX INTEGRA® uses the INTEGRA wall-switch to operate venting modules and blinds. Alternatively the modular skylight system can be controlled with an open system solution, connected to ± 24 V DC. Options include io-homecontrol® compatible systems and common building automation fieldbus systems.

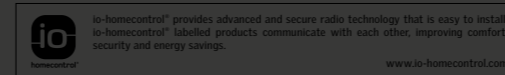

Read more about choice of control system in our Technical Handbook or see how the systems are connected in our Electrical Handbook. Both can be downloaded at: veluxcommercial.com

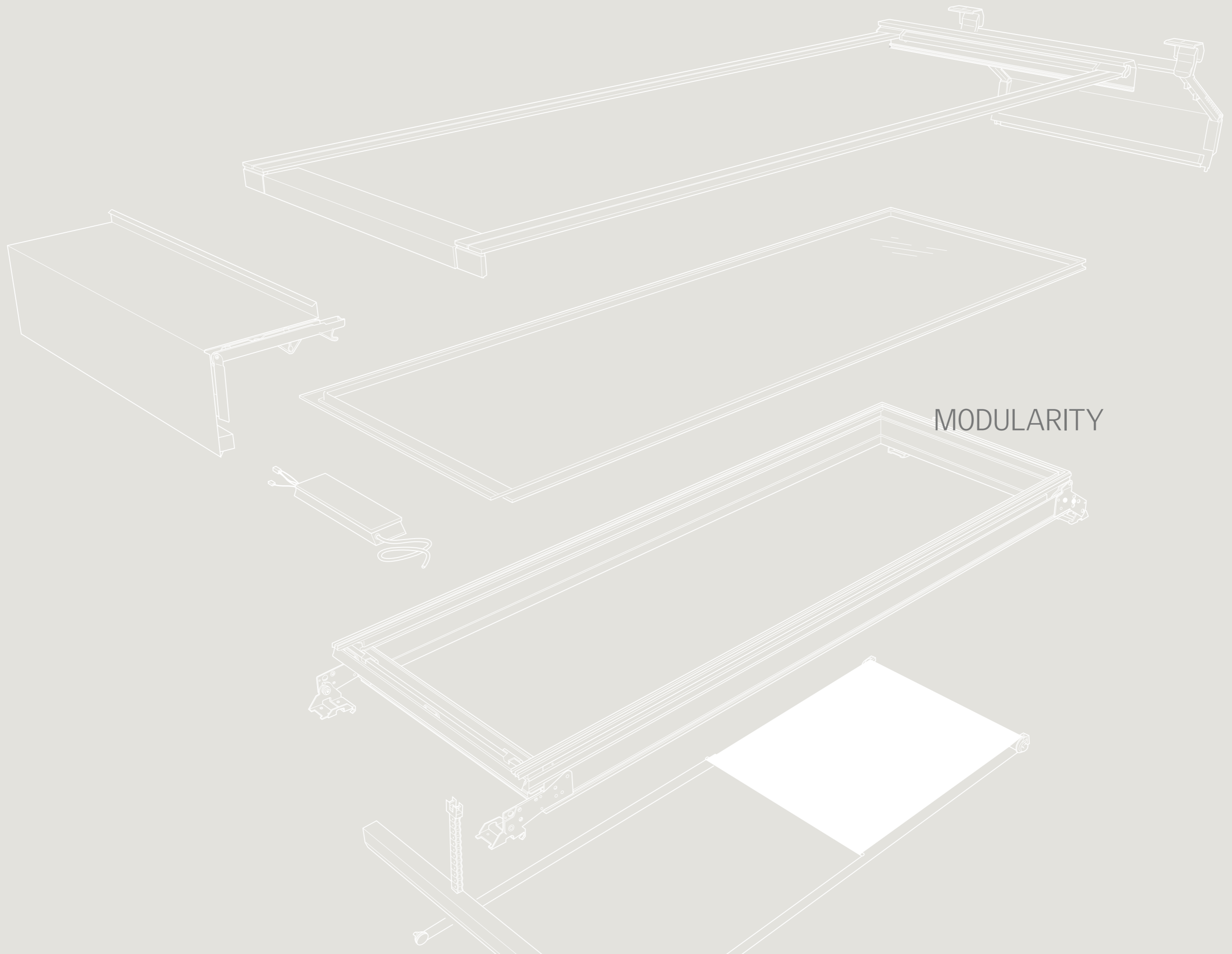

MODULARITY

The Module

The advantages of a truly prefabricated modular system

Prefabricated modularity offers a great number of advantages, at every step in the process. From planning and design to the moment the roof is sealed off with magnificent skylights. Modularity offers:

- Known performance, classifications and behaviour, easing the specification phase.
- Predictability of time frame and estimation of manpower in the installation phase.
- Security for years to come through support and maintenance.
- Clarity and speed for all implicated stakeholders in the building process.

Modularity is a shortcut to creating sustainable buildings with all the necessary approvals and classifications.

Modularity in every single product

All modules are produced offsite at our factory, meaning every single component is rigorously tested and integrated in a controlled environment. Each component is also of the highest premium quality and is built to stand the test of time.

All prefabricated modules are CE-marked in accordance with EN 14351-1, and delivered with customized flashings and integrated insulation.

Highly durable, with VELUX modular skylights you can expect a lifespan of 30 years.

For more on performance and classifications, go to page 45.

The System

The modules fit perfectly together to create a seamless, watertight system

From order placement to on-site delivery, VELUX modular skylights are designed, manufactured and packaged to support a streamlined installation process.

The easy installation process allows you to seal off the roof within days - regardless of the weather - letting you get to work inside the building with speed and efficiency.

See more on fast and easy installation on page 68.

**Up to
3 times faster
installation***

*Than other rooflights.
Proven by installers on
construction sites

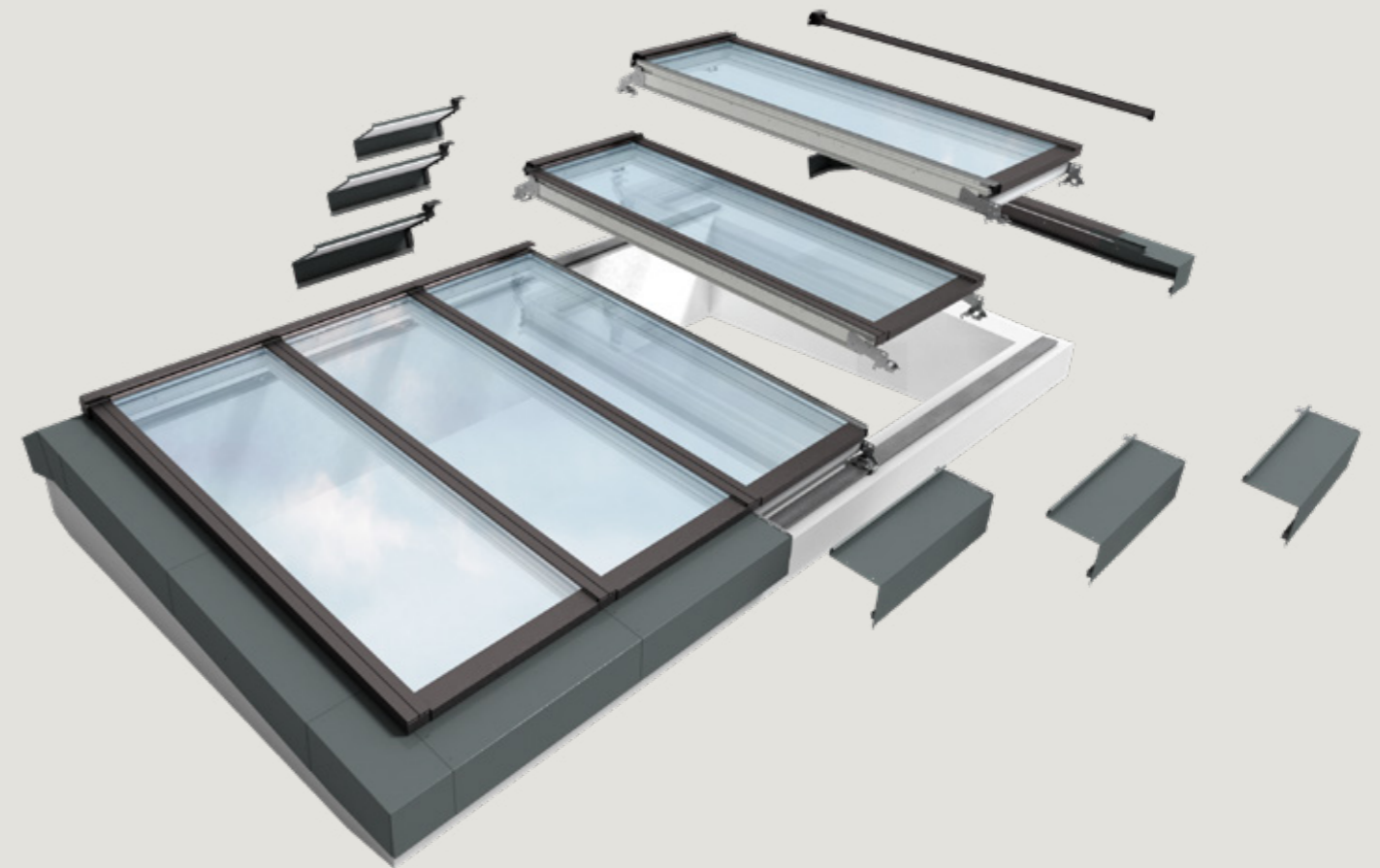
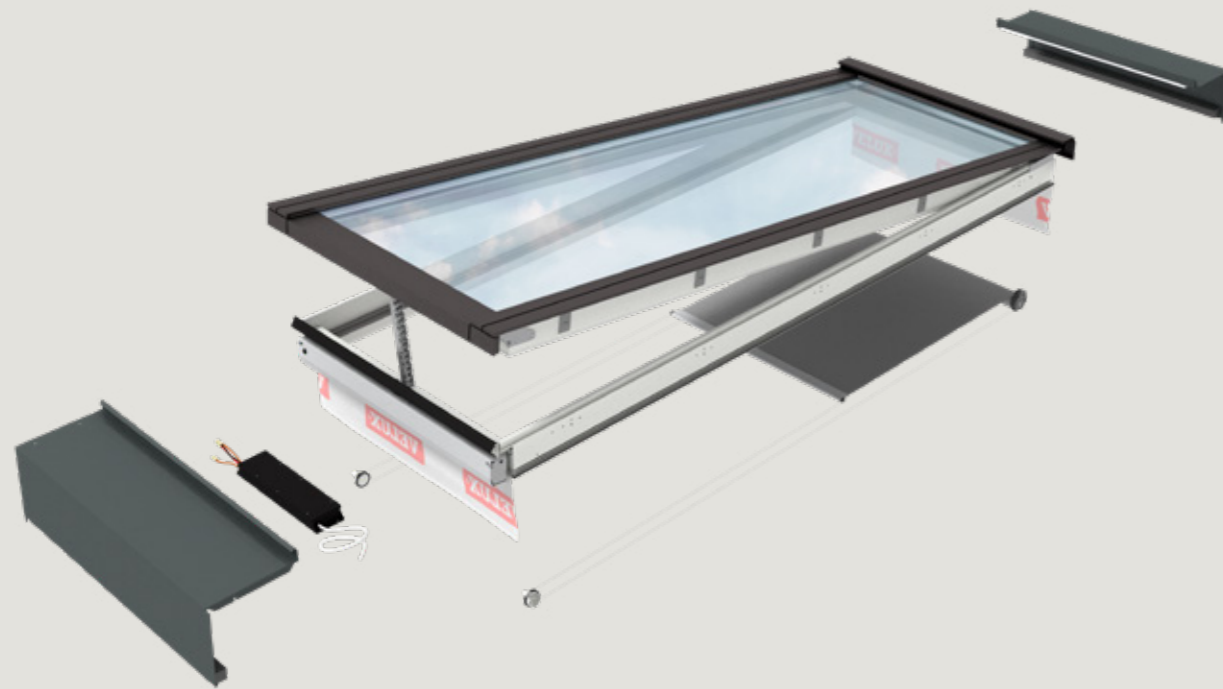

The Solutions

The versatile skylight system allows you to create a range of different designs for a variety of commercial buildings, such as shopping malls, offices, schools, cultural buildings, public spaces and health-care facilities.

Step solutions
are available from
spring 2019*

*Launch projects possible before that.

Mono pitched solutions

Longlight 5 - 30°

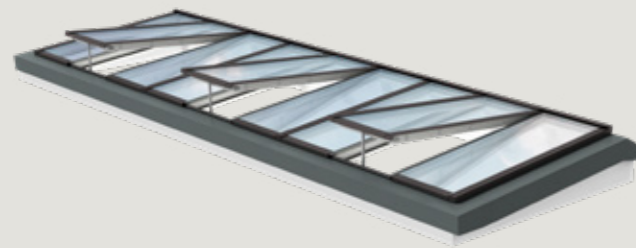

Wall-mounted Longlight 5 - 45°

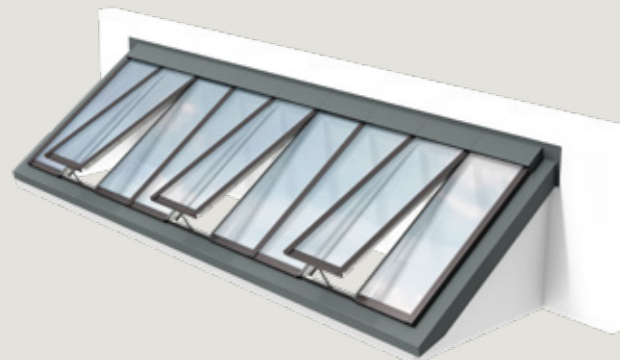

Northlight 25 - 90°

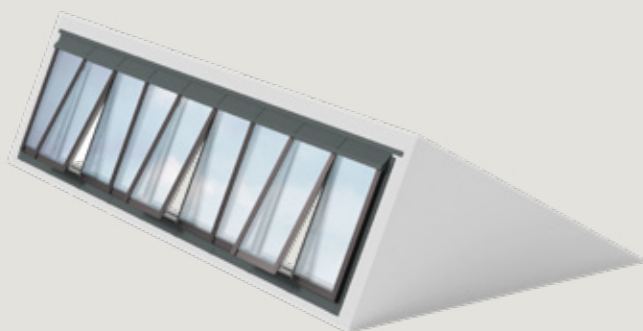

Dual pitched solutions

Ridgelight 25 - 40°

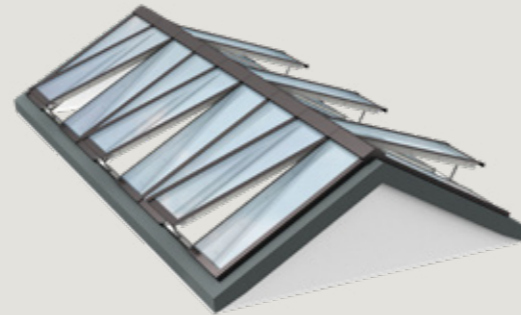

Ridgelight at 5° with Beams

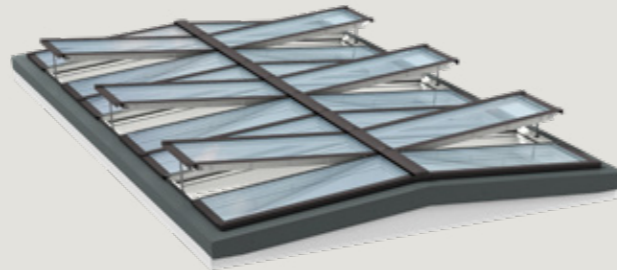

Step solutions

Step Longlight 5 - 25°

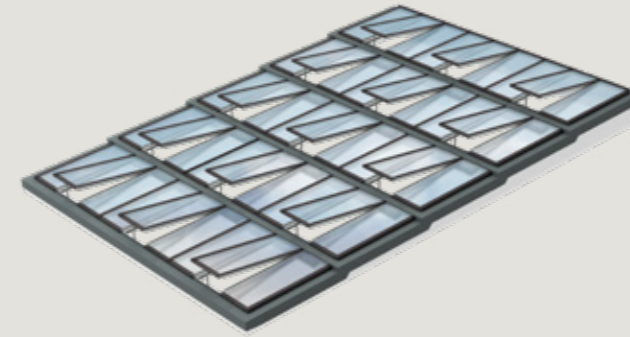

Step Ridgelight 25°

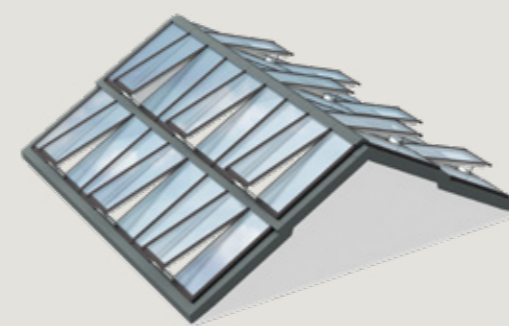

Step Ridgelight 5 - 25° on Girder

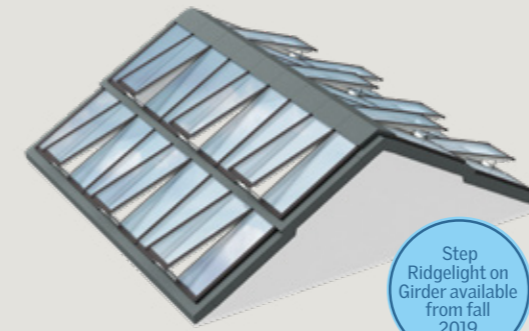

Step
Ridgelight on
Girder available
from fall
2019

Atrium solutions

Atrium Longlight 5 - 30°

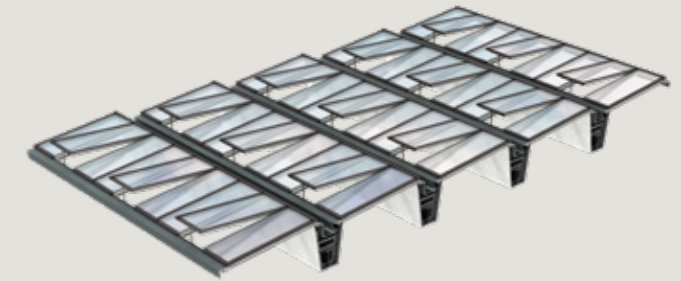

Atrium Ridgelight 25 - 40°

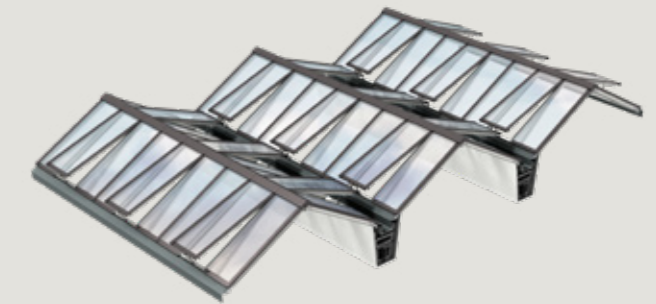

Atrium Ridgelight at 5° with Beams

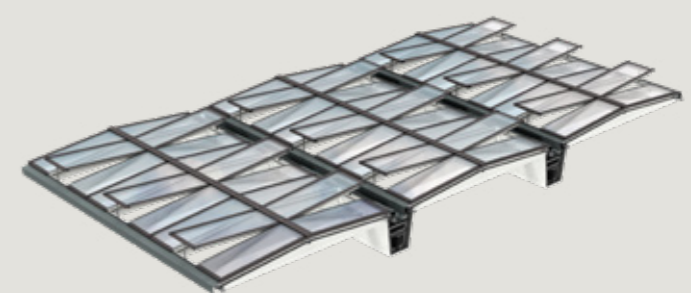

Functions

Modular skylights are available as fixed and venting modules. Due to a hidden chain actuator, fixed and venting skylight modules are visually identical in the closed position. Venting modules are top-hung and exists in comfort and smoke ventilation versions.

Smoke ventilation modules are dual function ventilators and can thus be used for both comfort and smoke ventilation. All smoke ventilation modules sizes are approved for smoke ventilation in accordance with EN 12101-2:2003.

The unique bracket system that makes every single module fit all our solutions

Designing with VELUX modular skylights is like a helping hand in your design process. The secret is our patented and unique bracket system – but what does this mean for you? Greater speed, freeing up more time for the fun stuff: designing and creating.

For a faster and more value-driven design process

The modularity of our skylights makes your design process much more straightforward. Use our CAD freeware tools with BIM objects. Just drag, drop and multiply – quickly, easily and accurately. Read about VELUX modular skylights freeware tools on pages 74-75.

Download
CAD with BIM
objects

[Download at veluxcommercial.com](https://www.veluxcommercial.com)



Fixed skylight module

Code: HFC



Motorized comfort venting skylight module

Code: HVC
Opens up to 410 mm

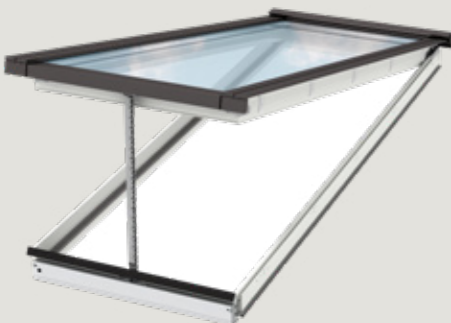

Motorized smoke ventilation skylight module

Code: HVC-A
Opens up to 700 mm in less than 60 sec.

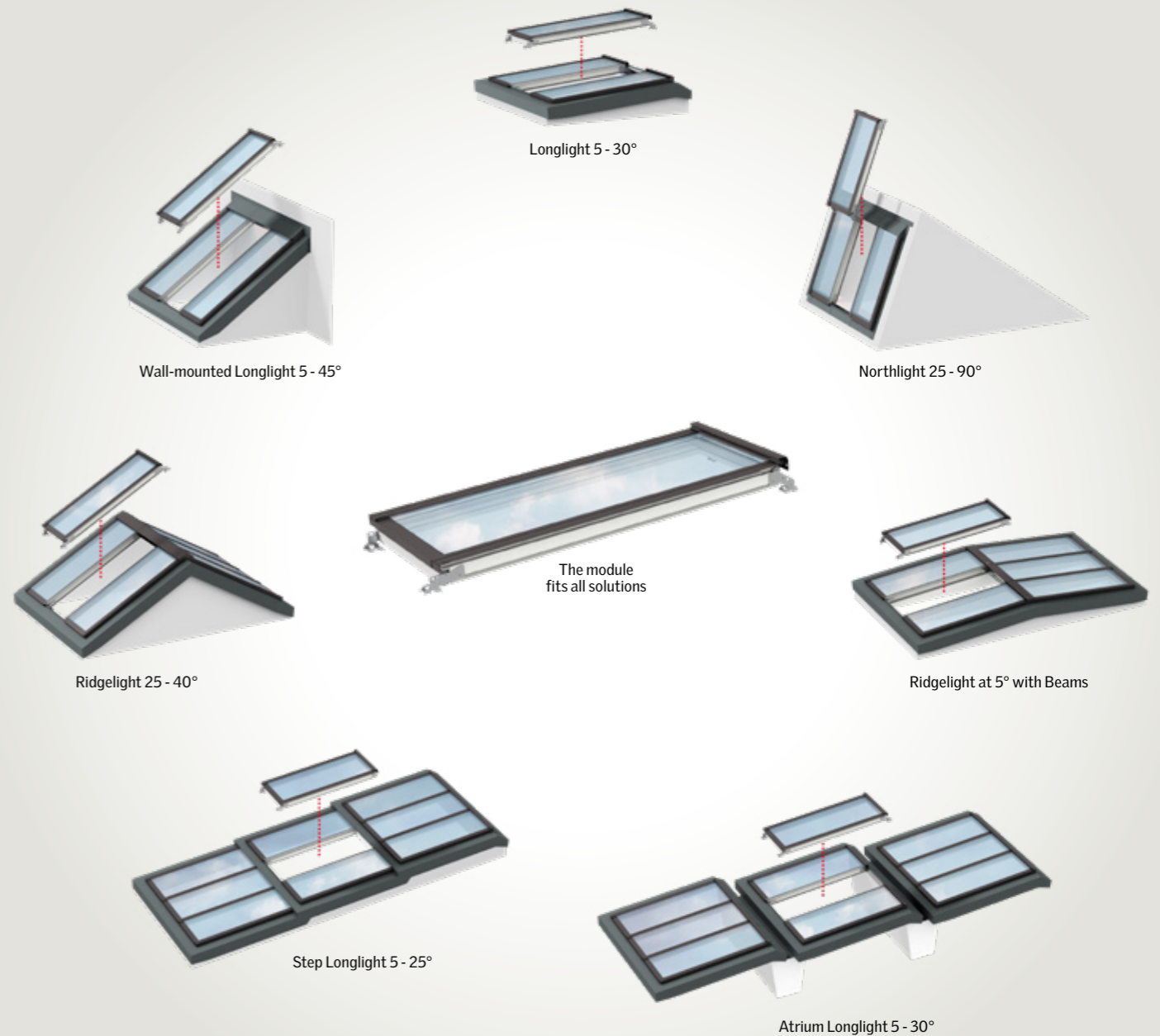

How to measure the modules

Width and height of the modules are determined by the exterior width and height dimensions of the frame – not the measurements of the cladding, flashing or brackets.



Venting skylight modules have a recommended minimum installation height of 2.5 m above floor level (inside) and ground level (outside). In case of installation below that level, safety measures must be applied by the installer/user to prevent serious injury.

Size grid

Standard size Special size, functional limitations may apply

Fixed modules

mm	675	750	800	900	1000
600	‡	‡	‡	‡	‡
800					
1000					
1200					
1400					
1600					
1800					
2000					
2200					
2400					
2600	* Δ	* Δ	*	*	*
2800	* Δ	* Δ	*	*	*
3000	* Δ	* Δ	*	*	*

Comfort ventilation

mm	675	750	800	900	1000
600					
800	○	○	○	○	○
1000					
1200					
1400					
1600					
1800					
2000					
2200					
2400					

Smoke ventilation

mm	675	750	800	900	1000
600					
800	○	○	○	○	○
1000	○	○	○	○	○
1200	○	○	○	○	○
1400	○	○	○	○	○
1600	○	○	○	○	○
1800	○	○	○	○	○
2000	○	○	○	○	○
2200	○	○	○	○	○
2400	○	○	○	○	○

* Module height above 2400 mm is delivered with an extra strong glazing unit only.

Δ No roller blinds available.

○ Only open system actuator available.

‡ Not available for Ridgelight.

For size specific load capacity, please contact us. If roller blinds are requested for smoke venting modules, please refer to local fire authorities for permission.

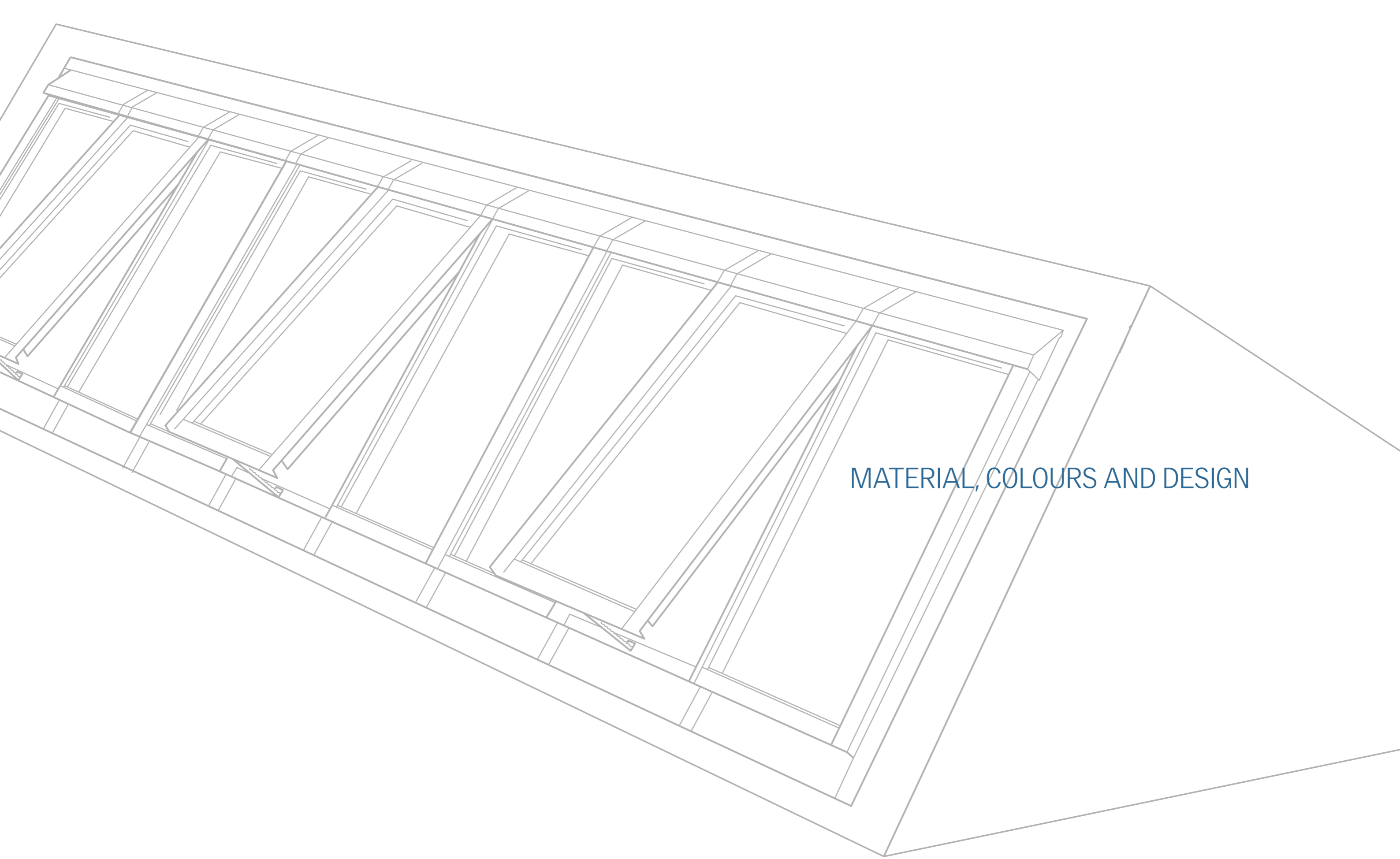

MATERIAL, COLOURS AND DESIGN

Interior colour

Material/Colours

Standard colours

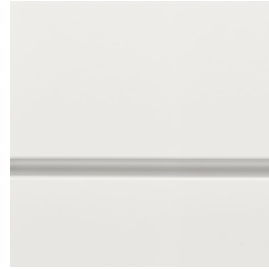

FRAME AND SASH WHITE

Material: Pultruded composite (approx. 80% fibreglass and 20% polyurethane)
Surface: Waterbased white coating
Colour: RAL 9010, gloss 30

Semi-standard colours – (often used colours but not standard)



FRAME AND SASH LIGHT GREY

Material: Pultruded composite (approx. 80% fibreglass and 20% polyurethane)
Surface: Waterbased light grey coating
Colour: RAL 7037, gloss 30



FRAME AND SASH DARK GREY

Material: Pultruded composite (approx. 80% fibreglass and 20% polyurethane)
Surface: Waterbased dark grey coating
Colour: RAL 7021, gloss 30



FRAME AND SASH BLACK

Material: Pultruded composite (approx. 80% fibreglass and 20% polyurethane)
Surface: Waterbased black coating
Colour: RAL 9005, gloss 30

Special colours



SPECIAL COLOURS

All other colours can be ordered at premium price.
Contact our sales team for more details.

Interior design

Components

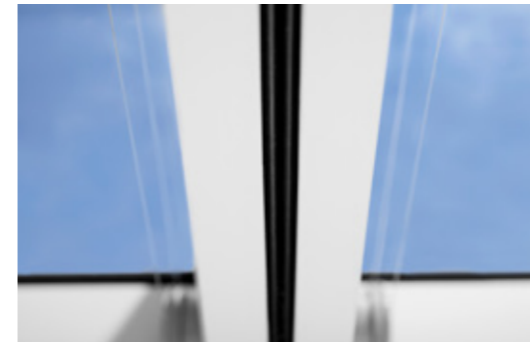

A black gasket ensures seamless and tight connection between two modules.



Connection between sash, glazing and outside cladding.



Roller blinds are kept taut and smooth by a strong, thin wire suspension.



Roller blind bottom wheel ensures position of the wire.



The chain in the hidden actuator raises the venting module to provide ventilation for comfort or smoke exhaustion.



The motor for roller blind operation is hidden inside the rod.

Exterior colour

Material/Colours

Standard colours

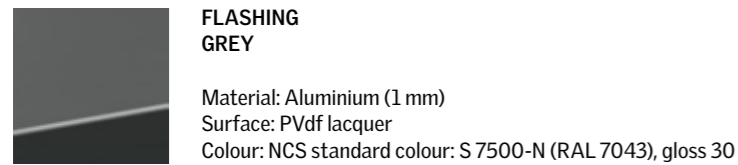
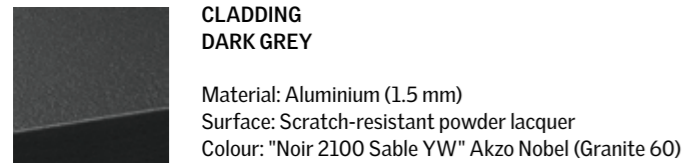

Semi-standard colours – (often used colours but not standard)

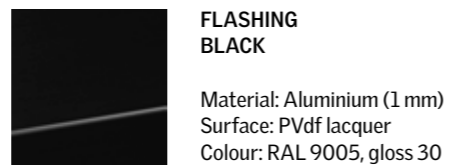
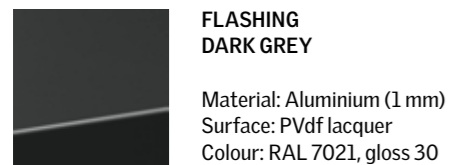
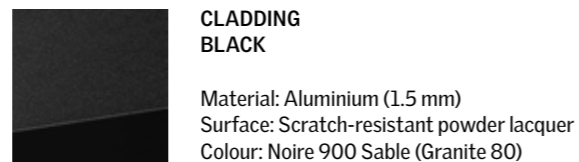
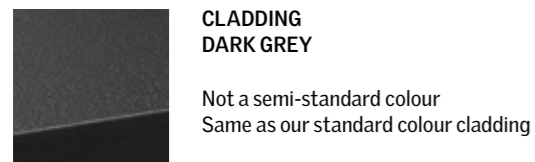
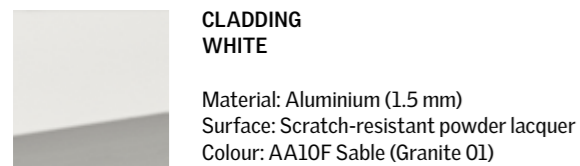

Special colours



Exterior design

Components



Assembly of middle and top section cladding.
Longlight 5-30°.



Assembly of side and top section cladding.
Flashing to the right. Longlight 5-30°.



Cladding and flashing assembly at the front of the rooflight.

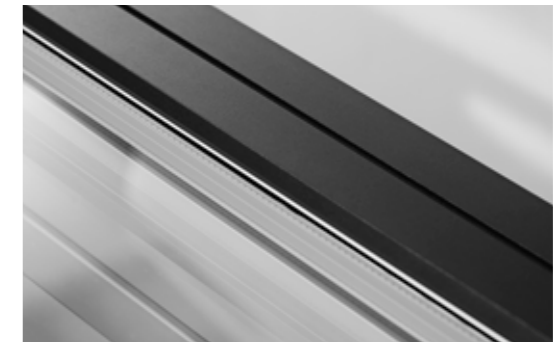

Middle section cladding connects two modules.



Side view of top covering. Longlight 5-30°.

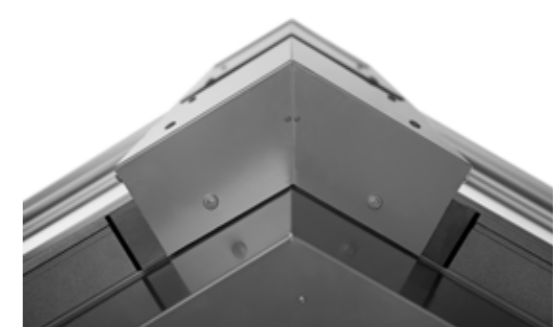

Side view of top covering. Ridgeline 25-40°.

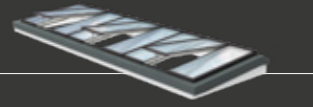

Hal C, Multi Sports Arena, Copenhagen, Denmark. Three Longlights, 60 modules.



ASSA ABLOY office, Apeldoorn, The Netherlands. One Longlight, 12 modules.



Dreamhill Kindergarten, Aarup, Denmark.
Eleven Longlights, 49 modules.



Green-Building KITA, Kindergarten, Köln, Germany.
Three Longlights, 9 modules.

Self Regional Healthcare, Greenwood, USA. Longlight modules.



Wall-mounted Longlight 5 - 45°



Church, Erkelenz, Germany. Wall-mounted Longlight, 30 modules.



De Utrecht Community, UCo, Utrecht, The Netherlands. Seven Northlights, 210 modules.



Schöllkopf Backwaren, Waiblingen, Germany.
Three Northlights, 54 modules.

Sågbäcksgymnasiet, Stockholm, Sweden. Four Northlights, 104 modules.



Ridgelight 25 - 40°

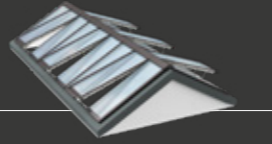

De Asseburg Shopping Mall, Bemmel, The Netherlands. One Ridgelight, 90 modules.

Old Firestation, Architect office, Leverkusen, Germany. One Ridgelight, 22 modules.



The Houtloods (transformation of old railway warehouse), Tilburg, The Netherlands. One Ridgelight, 124 modules.

Ridgelight at 5° with Beams

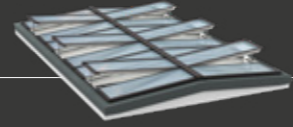

PS.Speicher, Museum, Einbeck, Germany. Ridgelight at 5° with Beams, 50 modules.



Roskilde Cathedral School, Roskilde, Denmark. Two Ridgelight at 5° with Beams, 50 modules.

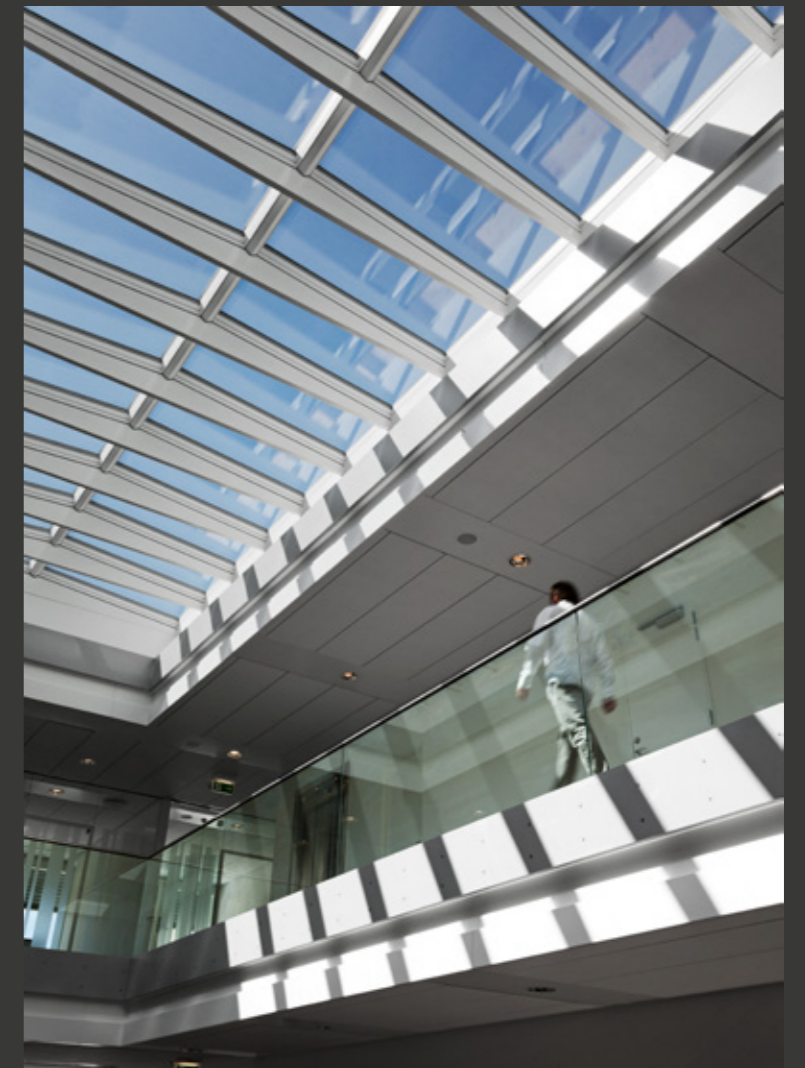

ATP, Vordingborg, Denmark. Ridgelight at 5° with Beams, 26 modules.

Atrium Longlight and Atrium Ridgelight

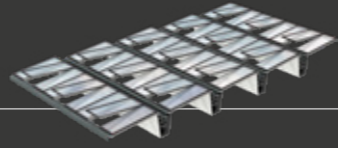

Experimentarium, Hellerup, Denmark. Two Atrium Longlights, 159 modules.



Trumpington Community College, Cambridge, United Kingdom. One Atrium Longlight + several Longlights, 170 modules. Five Wall-mounted Longlights, 69 modules. Two Northlights, 6 modules.

University of Southern Denmark, Odense, Denmark. Two Atrium Longlights, 367 modules.





Hessenwaldschule, Weiterstadt, Germany. One Atrium Longlight, 84 modules



German Center for Neurodegenerative Diseases, DZNE, Bonn, Germany.
One Atrium Longlight, 28 modules and one Atrium Ridgelight at 5" with Beams, 110 modules.

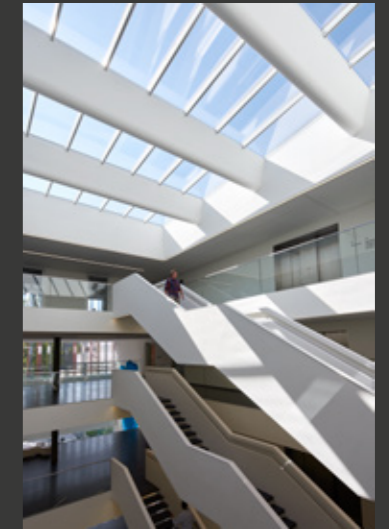

Genmab, Research Facility of Biotechnology, Utrecht, The Netherlands. One Atrium Longlight, 128 modules.



Utopia Library, Aalst, Belgium. One Atrium Longlight, 64 modules.



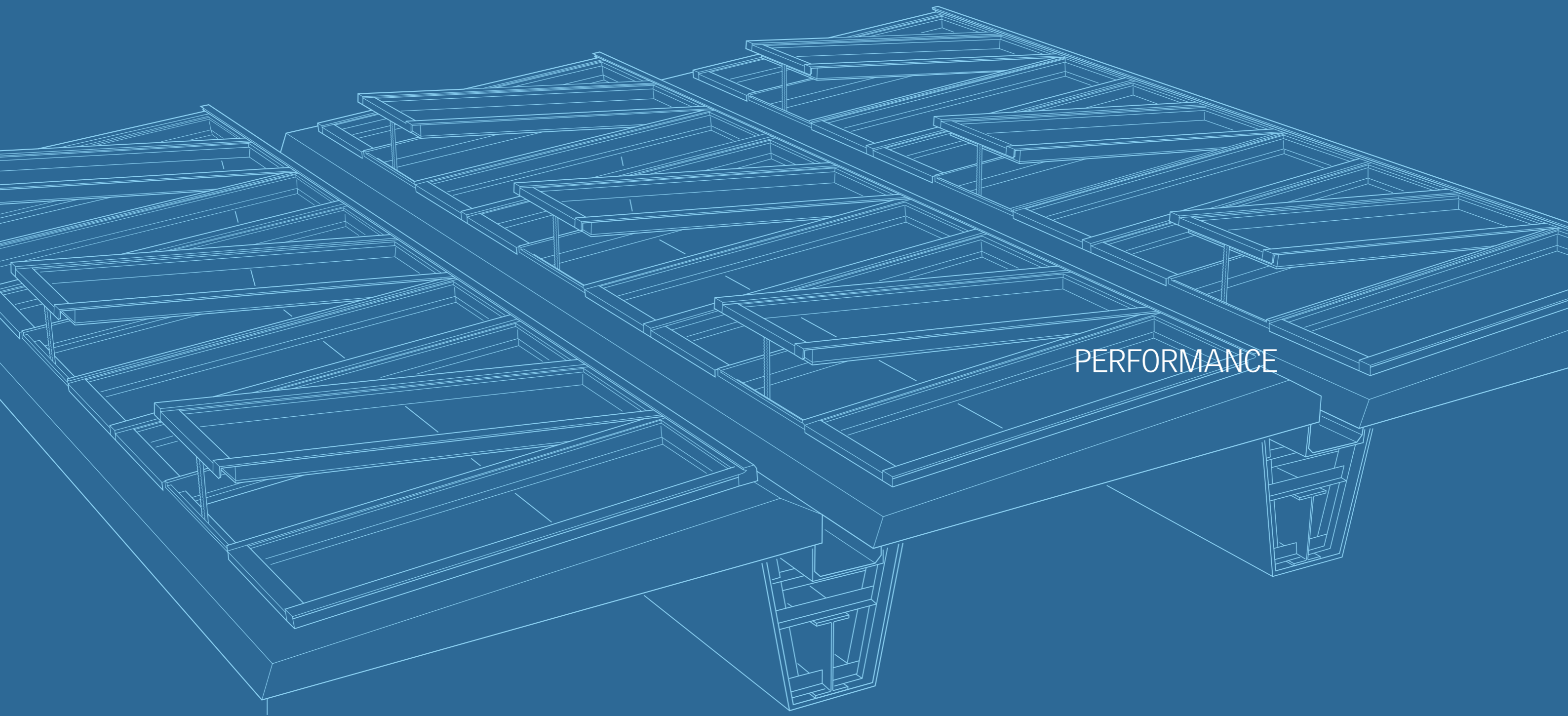

PERFORMANCE

Glazing

Glazing and U-values

Modular skylights come with low energy double or triple glazing with foil-laminated inner glazing for added safety and three different coating options.

The coatings are optimised to meet the desired levels of solar heat gain, sun protection, light transmittance and colour rendering.



- Thermal transmittance in accordance with EN 14351-1:

Modules with double-glazing:
 $U_w = 1.3-1.5 \text{ W/(m}^2\text{K)}$

Glazing variant: 10, 11, 12



- Thermal transmittance in accordance with EN 14351-1:

Modules with triple glazing (down to):
 $U_w = 0.86-1.1 \text{ W/(m}^2\text{K)}$

Glazing variant: 16, 17, 18



Read more about glazing units in our Technical Handbook
 Can be downloaded at: veluxcommercial.com

Glazing unit with advanced sun protection coating

Glazing with low emissivity coating (LowE)

Variant 10

Light transmittance: T-value = 79%
 Solar factor: g-value = 59%
 Colour rendering index: $R_a = 96$

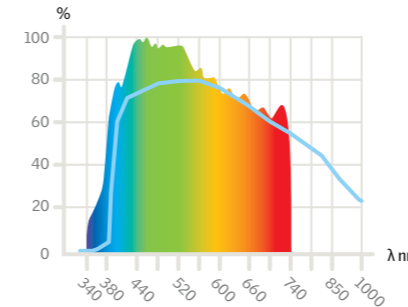
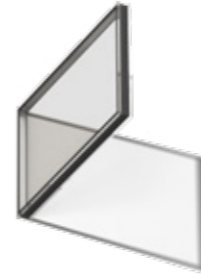

Glazing with light sun protection coating (Sun1)

Variant 11

Light transmittance: T-value = 50%
 Solar factor: g-value = 28%
 Colour rendering index: $R_a = 91$

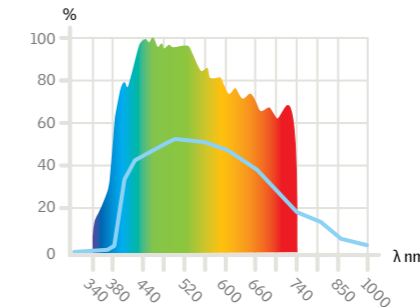

Glazing with enhanced sun protection coating (Sun2)

Variant 12

Light transmittance: T-value = 18%
 Solar factor: g-value = 17%
 Colour rendering index: $R_a = 87$

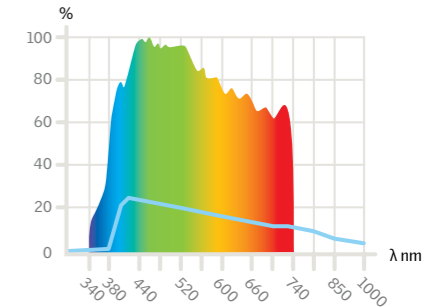

Spectral values (wave length in nm)
 Visible daylight tau

All of the above mentioned values are in accordance with EN 410.

Colour simulation

Your choice in coating will affect the amount of penetrating light as well as the natural colouring of the interior.

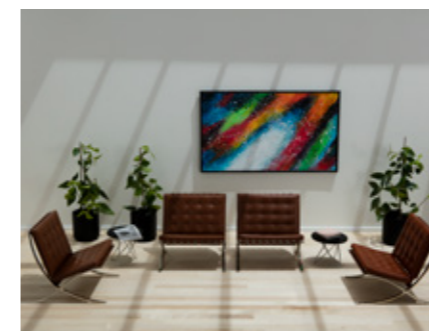

Glazing with low emissivity coating (LowE)



Glazing with light sun protection coating (Sun1)

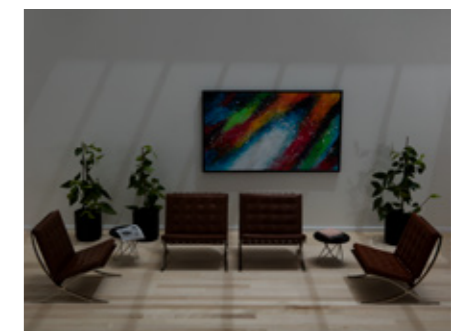

Glazing with advanced sun protection coating (Sun2)

Glazing unit with low emissivity coating and roller blind RMM

Glazing with low emissivity coating (LowE) and Roller Blind RMM 8806, White

Variant 10

Light transmittance: T-value = 30%
Solar factor: g-value = 34%
Colour rendering index: R_a = -

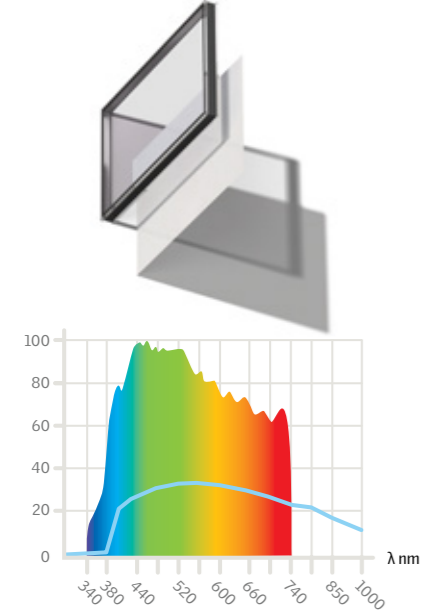

Spectral values (wave length in nm)
Visible daylight tau

All of the above mentioned values are in accordance with EN 410.

Glazing with low emissivity coating (LowE) and Roller Blind RMM 8805, Grey

Variant 10

Light transmittance: T-value = 8%
Solar factor: g-value = 41%
Colour rendering index: R_a = -

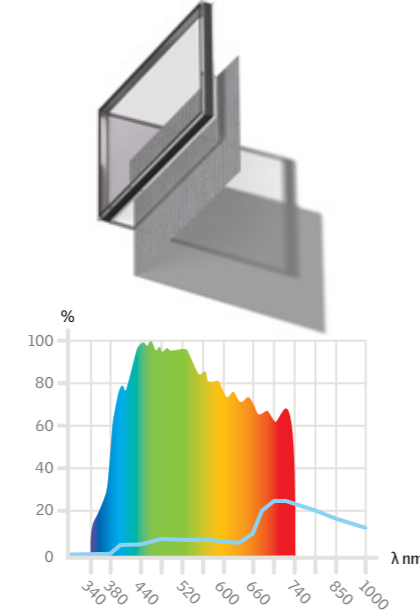

Glazing with low emissivity coating (LowE) and Roller Blind RMM 8807, Black

Variant 10

Light transmittance: T-value = 1%
Solar factor: g-value = 35%
Colour rendering index: R_a = -

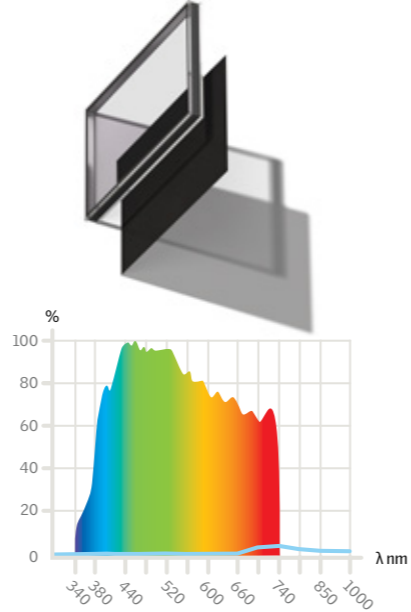

Glazing unit with opal or fritted surface

Glazing with low emissivity coating (LowE)

Variant 10

Light transmittance: T-value = 79%
Solar factor: g-value = 59%
Colour rendering index: R_a = 96

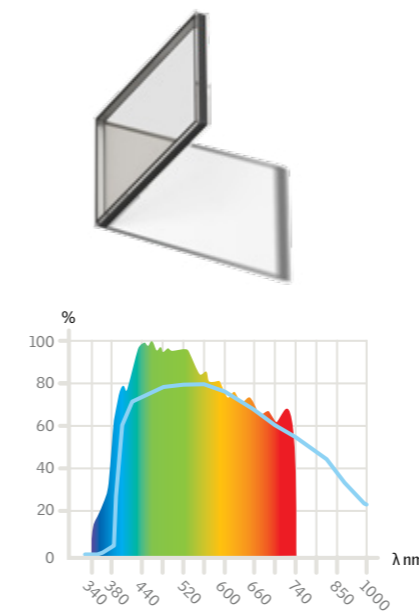

Spectral values (wave length in nm)
Visible daylight tau

All of the above mentioned values are in accordance with EN 410.

Glazing with low emissivity coating (LowE) and opal surface

Variant 10 + opal

Light transmittance: T-value = 57%
Solar factor: g-value = 38%
Colour rendering index: R_a = -

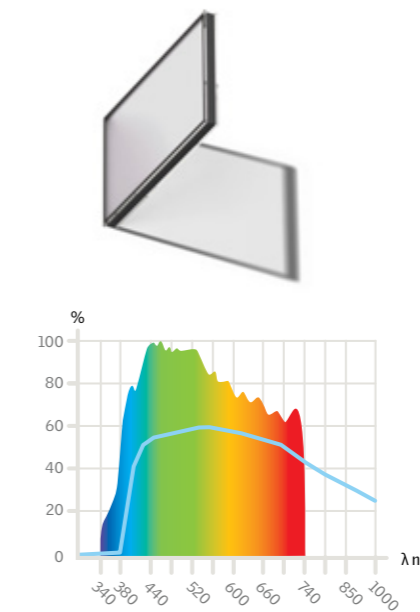

Glazing with low emissivity coating (LowE) and fritted surface

Variant 10 + fritted

Light transmittance: T-value = 53%
Solar factor: g-value = 35%
Colour rendering index: R_a = -

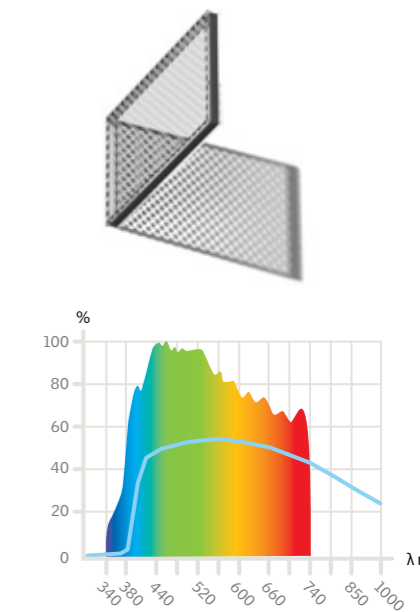

Fritted pattern: DG 10 covering 20%
Colour: White RAL 9010/9016

Colour simulation

Depending on the choice of roller blinds, the penetrating light will be affected together with the natural colouring of the interior. The blinds protect against heat and glare and help to control the amount of light in the room.

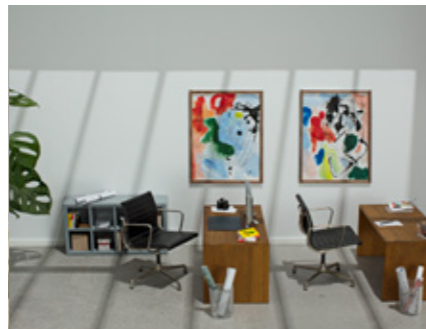

Glazing with low emissivity coating (LowE)
- No sunscreening

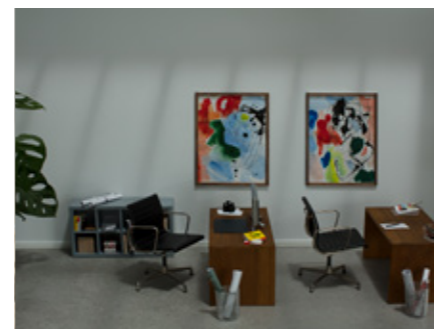

Glazing with low emissivity coating
and Roller Blind RMM 8806, White

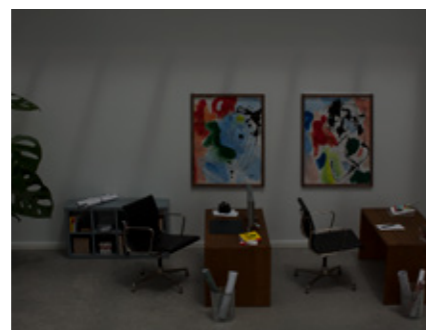

Glazing with low emissivity coating
and Roller Blind RMM 8805, Grey

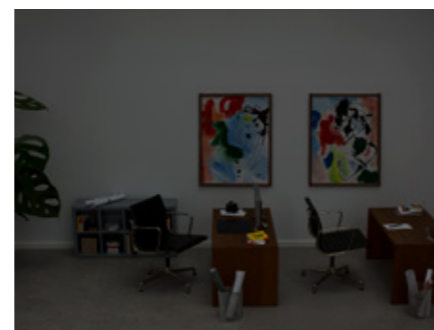

Glazing with low emissivity coating
and Roller Blind RMM 8807, Black

Colour simulation

Opal and fritted glazing variants lower contrast, bringing about more pleasant work environments, reducing heat intake and preserving luminance.

Note: Opal glazing preserves colour and luminance, while removing contrasts, creating the perfect lighting for schools and offices.

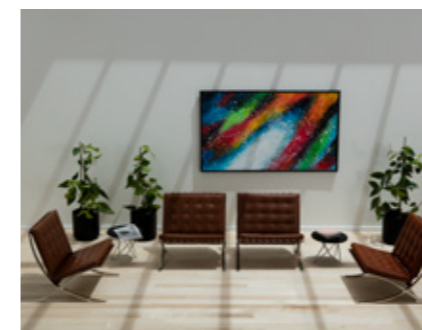

Glazing with low emissivity coating (LowE)



Glazing with coating (LowE) with opal glazing



Glazing with coating (LowE) with fritted glazing

Classifications

Because our products are prefabricated, we're able to test them extensively against all conceivable hazards and stressful events. Tests are carried out for all obligatory, mandated properties listed in harmonised product standards for windows and doors and as well for Natural Heat and Smoke Exhaust ventilators in a controlled environ-

ment. Further, we can test products for other commonly-used parameters our customers may require. All products are manufactured, assembled and delivered from the same heavily-controlled production line, leading to components with identical properties.



Watertightness

Classification: EN 12208

VELUX modular skylights: E1200

No water penetration up to 1200 Pa.
1200 Pa equals 155 Km/h (43 m/s).
(Hurricane = 32 m/s).



Resistance to wind load

Classification: EN 12210

VELUX modular skylights: Class C5

Frontal deflection measured at 2000 Pa is less than L/300.
(L = span length).
Safety test at 3000 Pa is passed.



Air permeability

Classification: EN 12207

VELUX modular skylights: Class 4

Highest air permeability classification
Draught measured to less than 2.6 m³/hm through joints at peak pressure of 600 Pa.



Strength

Ultimate strength under control

The ultimate strength is extensively tested for different installation and load scenarios in full scale and enable us to give indication to the anticipated strength of the entire skylight.

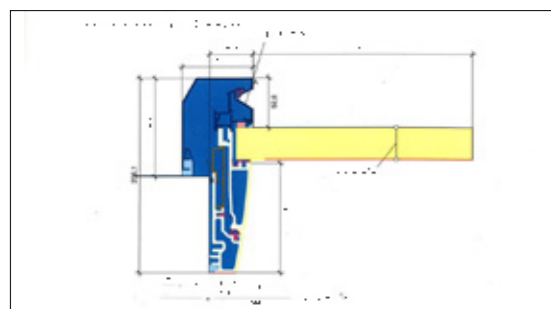

Energy

Value: EN 14351-1

Thermal transmittance of the entire window

Double glazing Triple glazing	Coating	Insulating Glass Unit IGU code	Pane	Area > 2.3 m ²	Area ≤ 2.3 m ²
			U _g W/m ² K	U _w W/m ² K	U _w W/m ² K
DG	LowE	10	1.1	1.4	1.5
TG	LowE	16	0.7	1.0	1.1

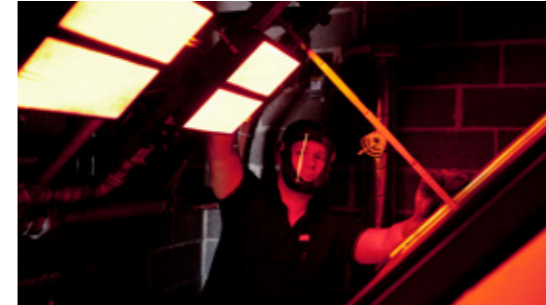

External fire performance

Classification: EN 13501-5 + A1

VELUX modular skylights

B_{ROOF} (t1): No penetration or burning droplets.
B_{ROOF} (t4): No penetration of roof system within one hour.



Reaction to fire

Classification: EN 13501-1 + A1

VELUX modular skylights: Class B-s1,d0 or B-s1,d2 depending on the choice of glazing unit

Slow development of fire and moderate heat and smoke release.



Resistance to fire

Classification: EN 13501-2 + A1

Fixed fire resistant module (HFS): REI30



Electromagnetic compatibility (EMC)

All electrical components are rigorously tested and comply with relevant EMC standards.

Ability to contain the fire in the compartment for minimum 30 minutes or more.



Safety at work

Fall-through protection

- Falling Through Safety Certificate in accordance with DIN 18008-6
- NARM ACR fragile roofing assembly Class A
- CWCT TN 66/67 Class 2

Watertightness

The module is fitted with a step pane to ensure water is lead safely off the unit and onto the roof surface. Likewise, interior condensa-

tion is drained from the construction via a channel system that distributes surplus water to the roof.

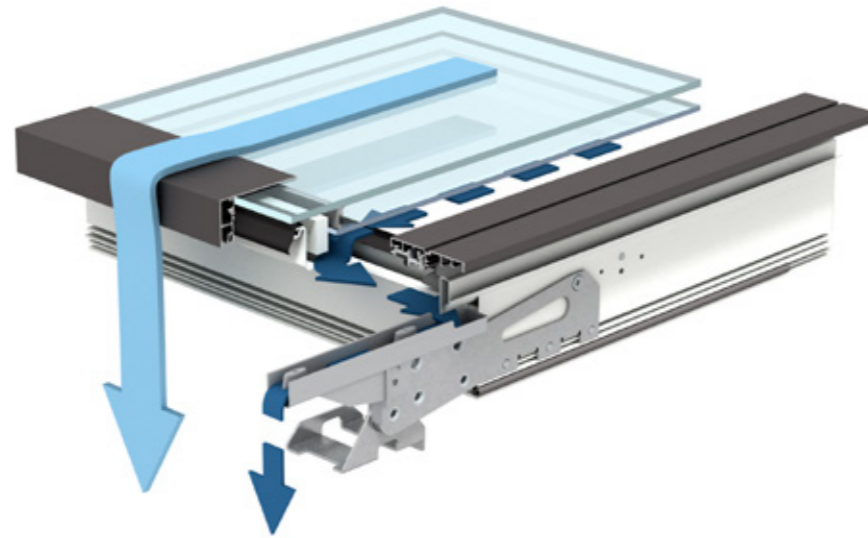

Linear expansion coefficient – (10^{-6} m/m K)

Low score means high thermal stability

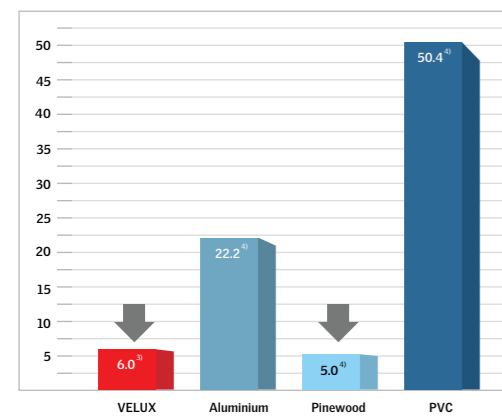

Traditional skylight materials fluctuate in form due to thermal changes, causing damage to gaskets and an increased risk of water ingress. Since the modular skylight composite contains 80% fibreglass, the profile properties are quite equal to those of the glazing unit. The similarity minimizes the risk of opposing movements in the construction, ensuring tightness of joints and a longer life expectancy of the application.

Full installation test



Installation and module watertightness is tested in a wind tunnel with wind speeds up to 37 m/s (hurricane force). The test uses a full installation with modules and flashing.

Airtightness

Modules are connected with a two-level gasket system that protects against air ingress due to excessive wind loads. The cladding, which is attached on top of the connected modules, contains sever-

al pressure compensation channels that reduce the load on gaskets and joints. The modules have obtained the highest classification for air permeability.

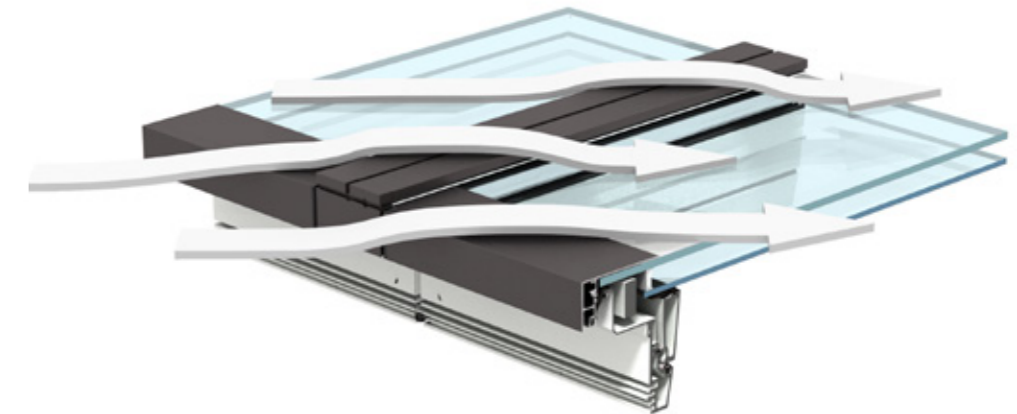

Air permeability



A two-level system with gaskets in the top and bottom ensures a very tight and durable connection between the two module profiles.

Strength

The modular profiles are made of an extremely tough composite material. The strength stems from a highly specialized pultrusion process, which creates a rare combination of high flexural strength

and unparalleled resistance to breakage. The unique mix makes the composite a safe and durable element as well as a strong measure against aesthetically unappealing deformation.



Load

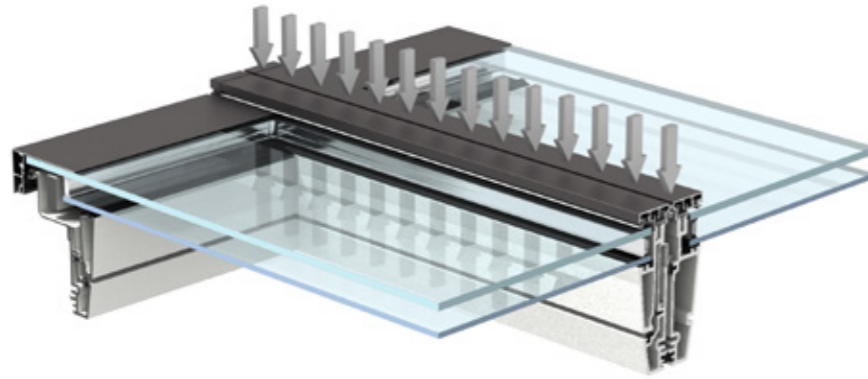

Flexural strength – (N/mm²)

High score means high strength (resistance to breakage)

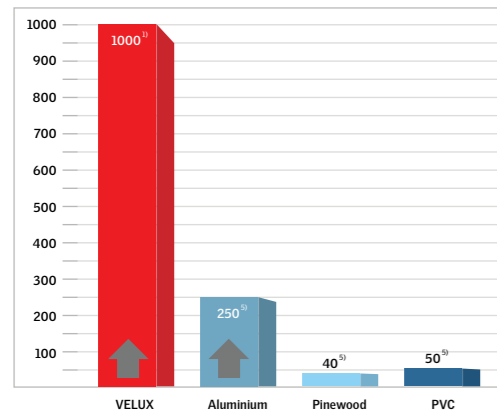

Compared to traditional skylight materials, the exceptional strength of the pultruded composite material allows longer and slimmer frame and sash profiles to be produced. As a result, large skylights with slim profiles become an option, which can lead to better aesthetic solutions.

Flexural Modulus (E-Modulus) – (GPa)

High score means little deflection

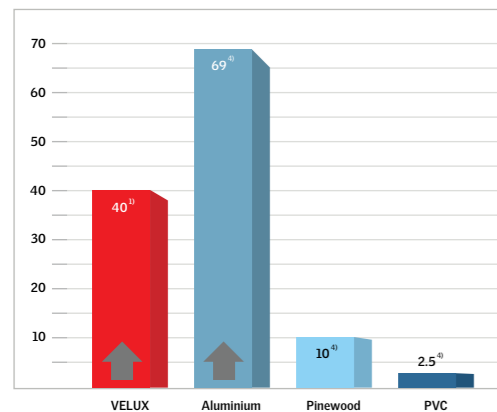

The high rigidity of the pultruded composite material makes the frame and sash extremely stiff. The rigid properties ensure reliable performance with very little deflection of the profiles and more durable aesthetics.

Modular skylights composite



A

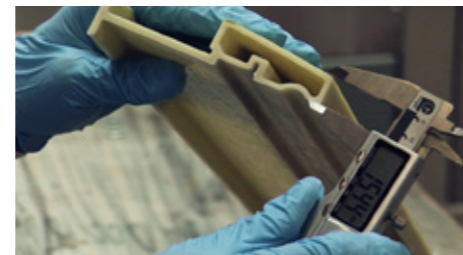

B

A To start the pultrusion process, strands of fibreglass are pulled from a fibre creel. The strands are pulled through a matrix that bundles the fibreglass to match the final geometric design.

B Following the matrix, strands enter a heated mould where fibreglass is mixed with polyurethane under high pressure. The resulting profile consists of 80% fibreglass and 20% polyurethane. Throughout the process, profiles are regularly tested for dimensional inaccuracies.

Energy

Very low thermal conductivity and an array of low-energy glazing options make the total modular solution exceptionally energy efficient. The system offers 2 or 3-layer glazing in combination with

three different coatings. The different combinations allow you to specify the product precisely according to your demands, whether you prefer heat control or protection against cold weather.



External cold air



Internal warm air

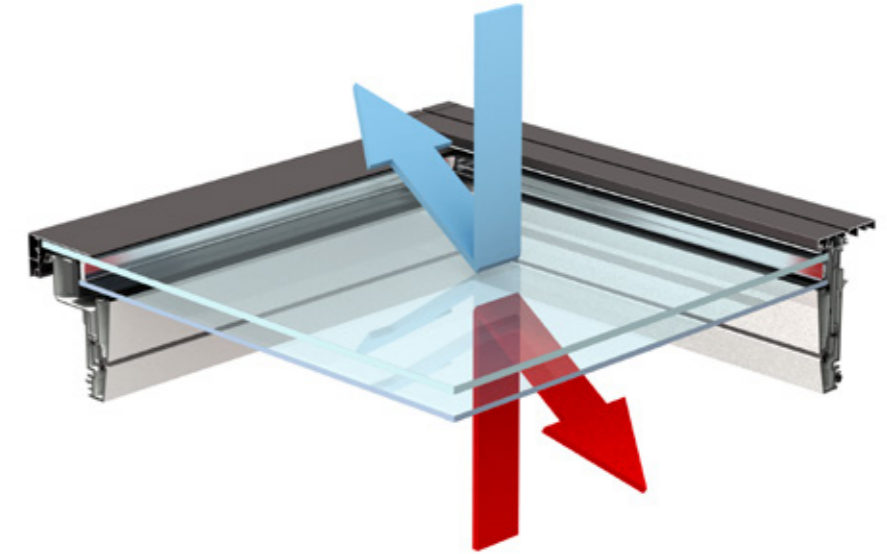

Thermal conductivity – (W/mk)

Low score means high insulating performance

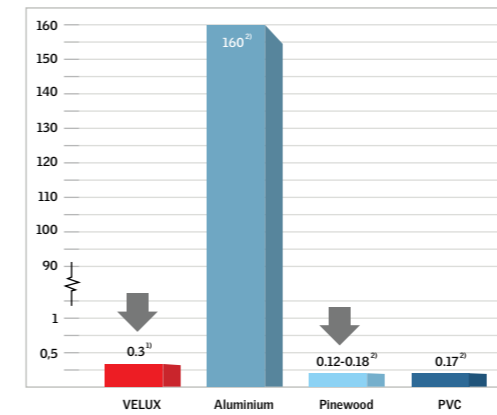

The special composite possesses extremely low-conductive properties that surpass traditional profile materials – a measure for high insulating performance.

Thermal insulation

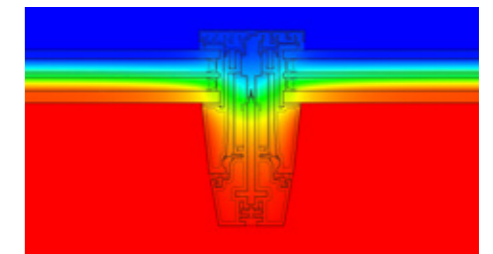

Thermal tests reveal the profile's ability to prevent cold bridging.



Low-energy glazing in combination with low-conductive profiles create an effective shield against all kinds of cold weather.

Certifications

Holistic approach to sustainability and certified buildings

Certifications achieve two purposes. The first is to ensure a healthy indoor climate for the people working, living and occupying a particular building. The second is to be able to monitor the building, continuously securing that conditions and climate are in compliance with required standards – now and into the future.

The different rating schemes that exist today vary widely in terms of overall scope, performance metrics and priorities in building

life cycle, yet they all share the ambition to create healthy and sustainable buildings.

VELUX modular skylights pursues the same holistic strategy, seeking to optimise energy efficiency, minimise environmental impact and ensure a healthy indoor climate.



University of Southern Denmark, Odense, Denmark



Hessenwaldschule, Weiterstadt, Germany

DSV Headquarters, Hedehusene, Denmark



Certifications

Our contribution to excellent indoor climate

Sustainable building certifications are tools we can use to measure and document sustainability, as well as, support integrated design and interdisciplinary collaboration. Certifications help shift the industry and drive innovation by formalising design and performance criteria so that what was once innovative becomes the norm.

The process of evolving certification tools forces stakeholders to raise green building standards in response to new factors such as the Paris Agreement. Certification systems have been extremely successful in raising awareness of sustainability in the building industry. Our next focus should be on real building behaviour and the impact on global warming.

The following is a wide range of certified buildings in which VELUX modular skylights contributed to the excellent indoor climate, helping them achieve outstanding ratings and classifications.

BREEAM®
★★★★☆
EXCELLENT



Energy Transition Company, The Netherlands, BREEAM Excellent

BREEAM®
★★★★☆
EXCELLENT



Genmab, Research Facility of Biotechnology, Utrecht, The Netherlands, BREEAM Excellent

BREEAM®
★★★★☆
EXCELLENT



Utopia Library, Aalst, Belgium, BREEAM Excellent



Siemens Head Office, Denmark, LEED Gold



Green Solution House, Denmark, DGNB and Active House

BREEAM®
★★★★☆
EXCELLENT



Trumpington College, United Kingdom, BREEAM Excellent

BREEAM®
★★★★☆
OUTSTANDING



Geelen Counterflow, The Netherlands, BREEAM Outstanding

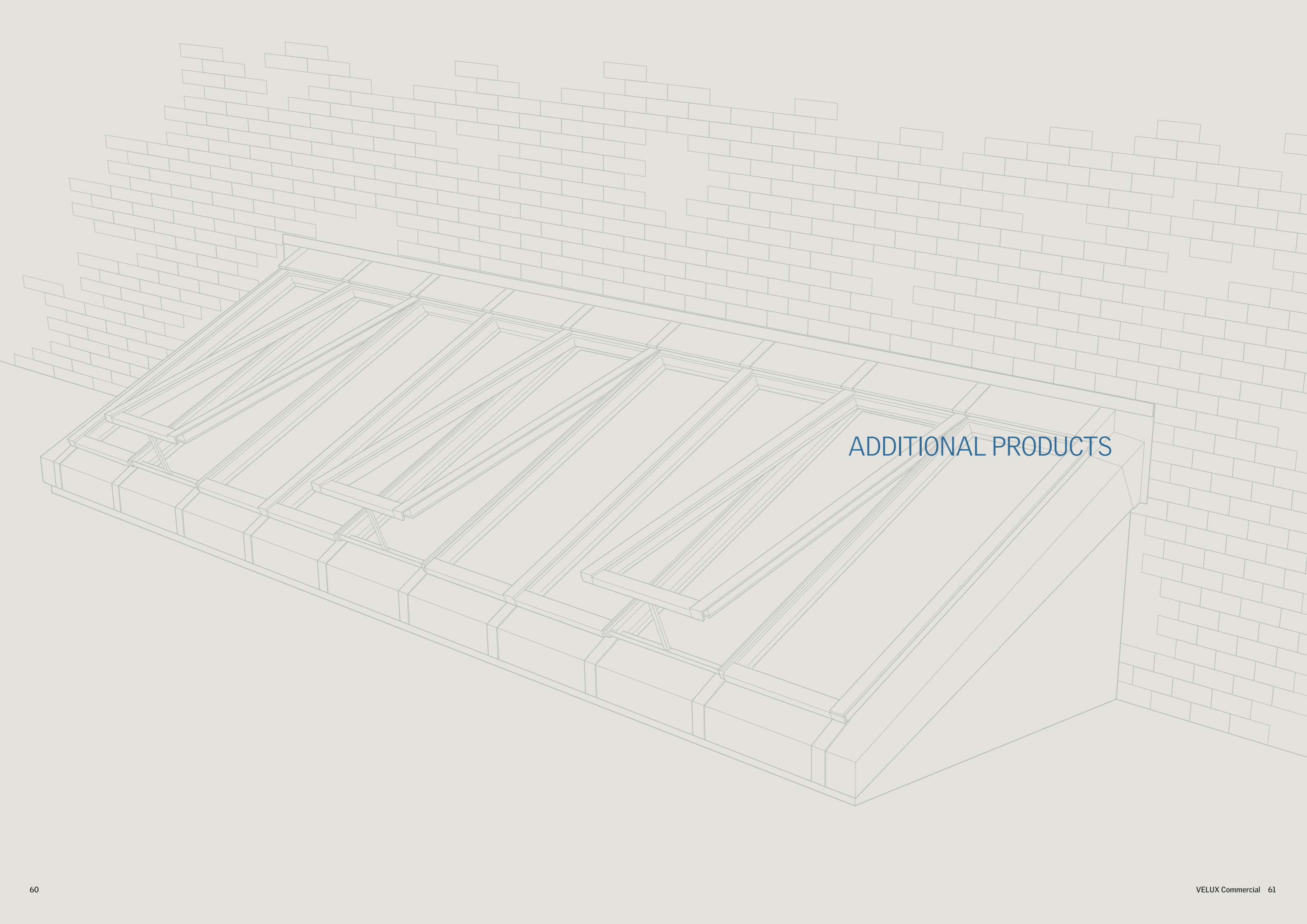

ADDITIONAL PRODUCTS

Sun screening – Roller blinds

The integrated roller blinds fit perfectly into the window opening, creating a seamless connection between sash and cloth. To support fast and safe installation of the blinds, it is possible to order roller blinds pre-mounted from the factory.

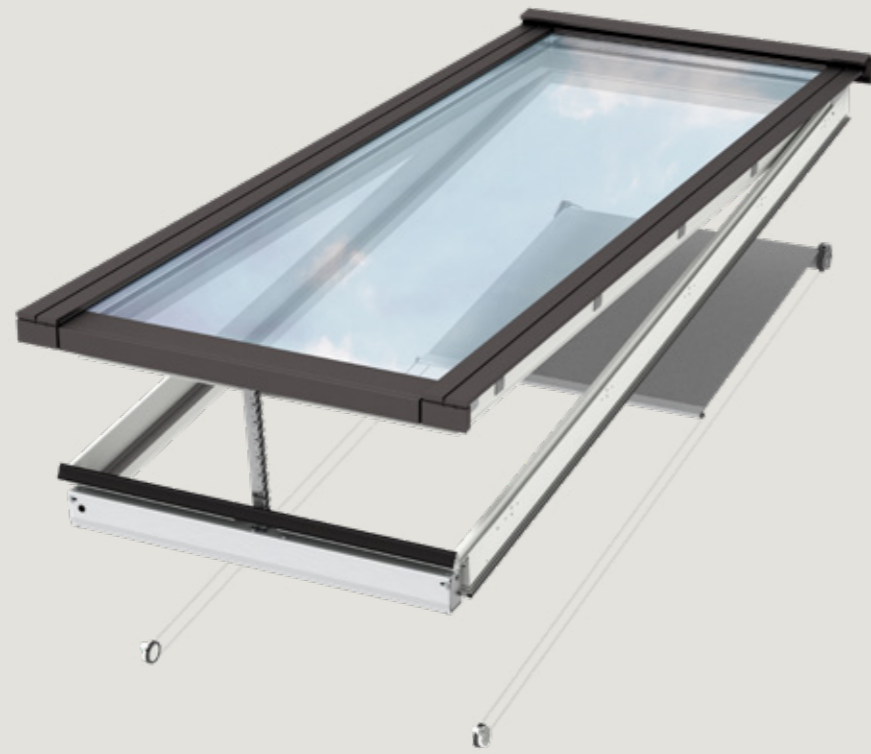

Sun screening – External awning blinds

Maintain a pleasant thermal indoor environment
The Topfix® VMS external awning blind by Renson protects the interior from excessive solar heating. The product is optimised

for VELUX modular skylights and compatible with both fixed and venting modules. Topfix® VMS awnings operate on mounting feet that fit perfectly onto the external surface of the modular profiles.



Fire retardant sunscreening

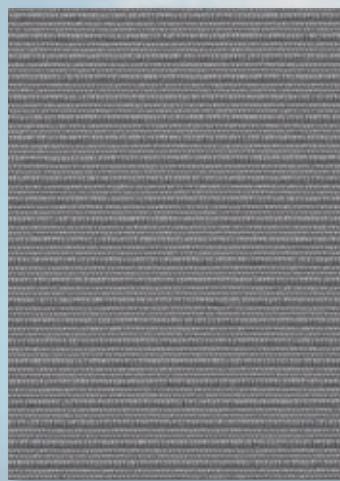

Grey
RMM 8805



White
RMM 8806

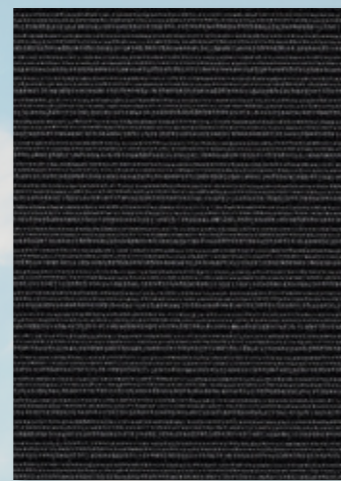

Black
RMM 8807



Wortmann Schuh-Holding KG, Detmold, Germany.
Ridglight 25-40°



Library Utopia, Aalst, Belgium.
Longlight 5-30°

Photovoltaic glazing



Green Solution House, Hotel and Conference Centre, Bornholm, Denmark.



Modular skylights are available with two different types of integrated monocrystalline photovoltaics:

- 1) The first type consists of a semi-transparent pane with one half covered in evenly distributed black squared photovoltaics, sized approx. 15 x 15 cm. The semi-transparent module converts solar radiation to electricity with up to 8% efficiency.
- 2) The second type is opaque and fully covered with photovoltaics without any transparency. The opaque module converts solar radiation to electricity with up to 13% efficiency.

Integrated photovoltaics are available in standard module widths from 800-1000 mm and heights from 1200-2400 mm (fixed and venting).

In order to achieve maximum output from photovoltaic modules, we recommend a solution, which is tilted towards equator and located in a shadow-free environment. As a rule of thumb, the installation should be pitched at an angle that equals the latitude minus 10 %.

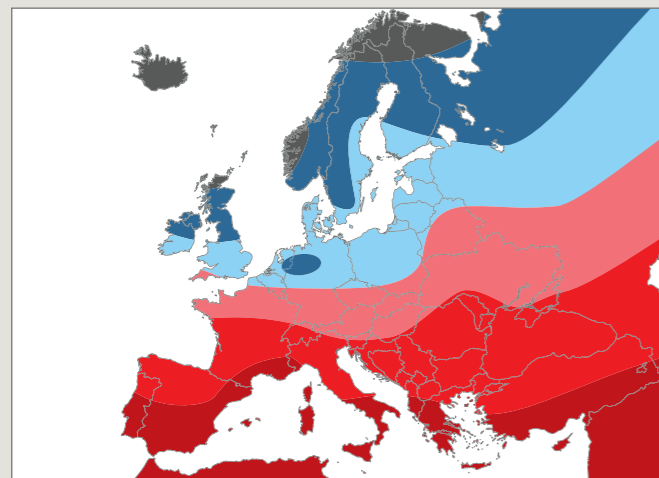

Map legend:

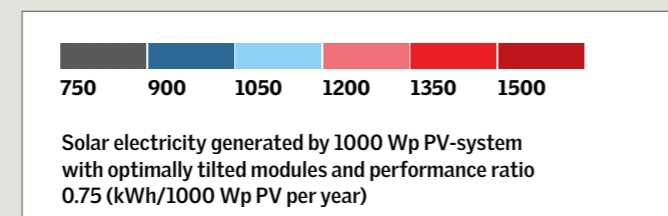
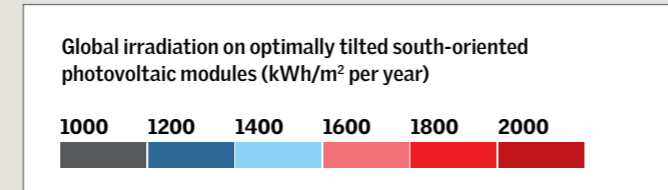

Sun screening – Electrochrome glass



Glazing with no coating
Visible light transmission 79%



Glazing with electrochrome glass
Visible light transmission 50%

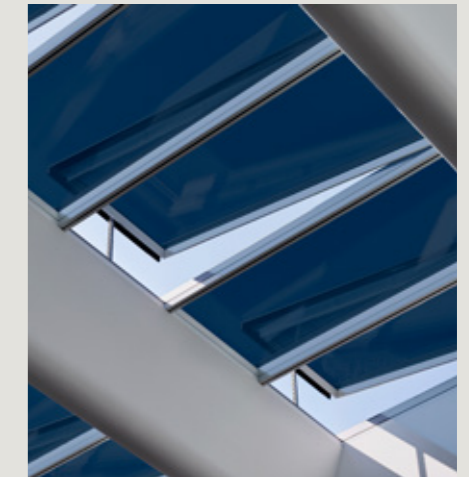

Glazing with electrochrome glass
Visible light transmission 1%

VELUX modular skylights are available with electrochromic panes. The electrochromic pane is an insulated glazing unit with electronic, tintable coating. The coating can be darkened on demand by applying a low voltage of electricity. The dynamic changing in tint provides exceptional control of daylight, glare and energy use without blinds or shades.

An easy-to-use control system allows anyone to operate the electrochromic panes with wall switches, a mobile app or with a building management system. A combination of the three is also possible.

Infill panel



Infill panel covering a wall inside a building



VELUX modular skylights are available with infill panels to accommodate structures, such as a ventilation shaft or an existing wall construction. Infill panels can also be used on the south-facing side of a Ridgelight to imitate a shed roof structure.

Smoke ventilation and wind deflector



Smoke ventilation

Smoke venting skylight modules provide smoke ventilation in accordance with EN 12101-2. VELUX modular skylights offer smoke venting modules that come with optional wind deflectors. The modules and deflectors are designed to reduce smoke accumulation inside the building in case of

fire. Our smoke venting skylight modules open up to 700 mm in less than 60 seconds. Smoke venting modules are only available with an Open System actuator. If you're interested in roller blinds for your smoke venting modules, please refer to local fire authorities for permission.

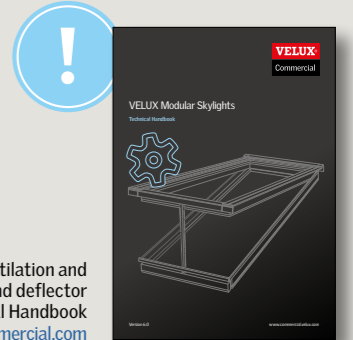
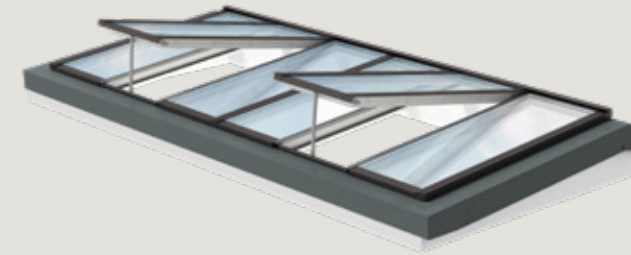

Read more about smoke ventilation and the great values behind our wind deflector in our Technical Handbook
Download at: veluxcommercial.com

Wind deflectors

VELUX modular skylights offer wind deflectors to ensure optimum smoke ventilation. The wind deflectors are designed to minimise the risk of air intake and let the smoke escape even when the wind conditions are unfavourable.

You can choose between two different wind deflectors. One that covers only one smoke venting module or one covering three modules, i.e. one smoke venting module in the middle, flanked by fixed modules on each side.

A deflector solution for a stand-alone smoke venting module

Wind deflector KCD 0040

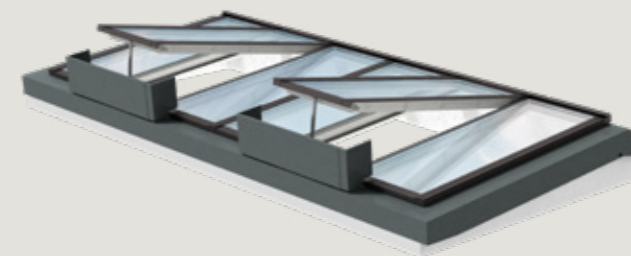

A shield off solution for larger configurations

Wind deflector KCD 0080

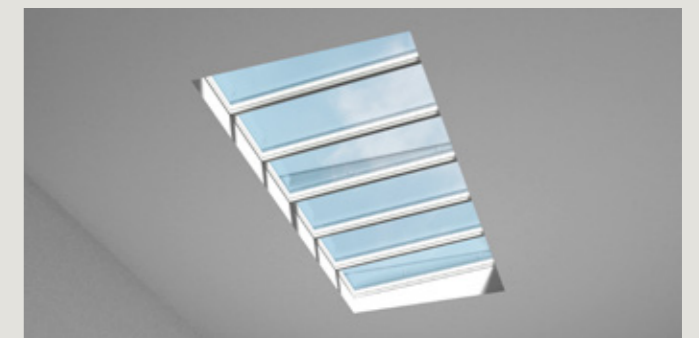
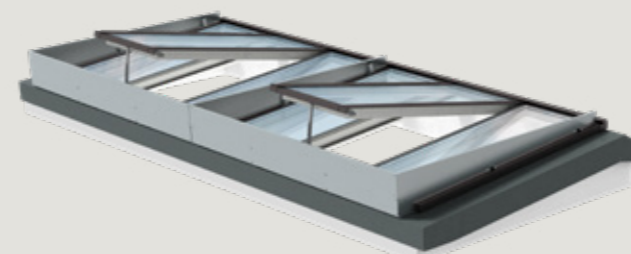

From the inside, the wind deflector KCD 0080 is hardly visible.

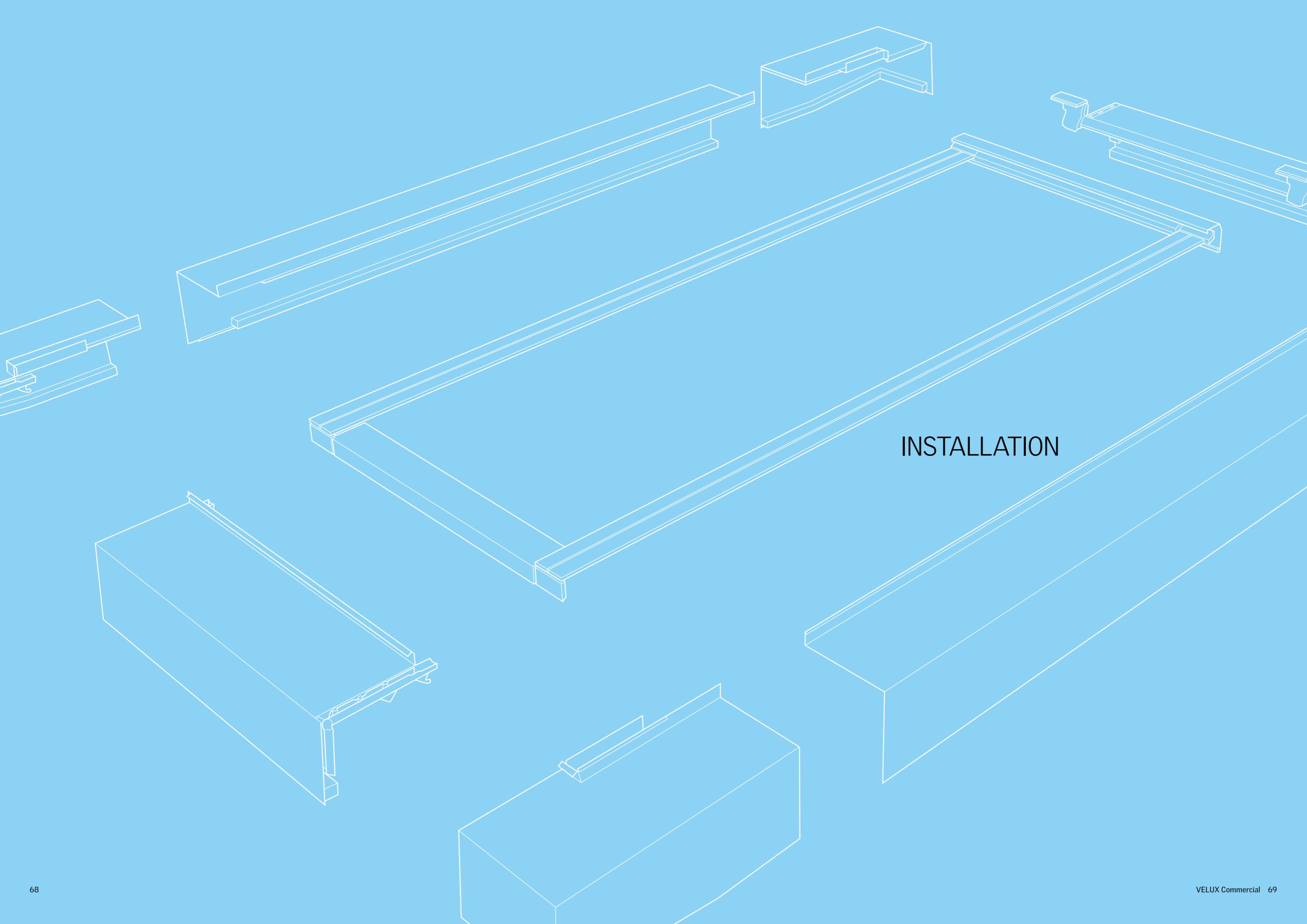

INSTALLATION

Designed for easy installation

All components are designed in accordance with the overall system. In our controlled facilities, we monitor all aspects of production to ensure a perfect fit and assembly. A unique bracket system with a simple clamp design guarantees a predictable installation process, which makes it possible to fit an entire module within minutes.

Easy installation process

VELUX modular skylights require an accurate fixed-dimension sub-

structure. Likewise, the strength of the sub-construction needs to be calculated from project to project, based on the building design and application size.

Thus, the sub-construction is not part of the prefabricated modular system. The VELUX Group does not take responsibility for the sub-construction. See page 76 for further information.

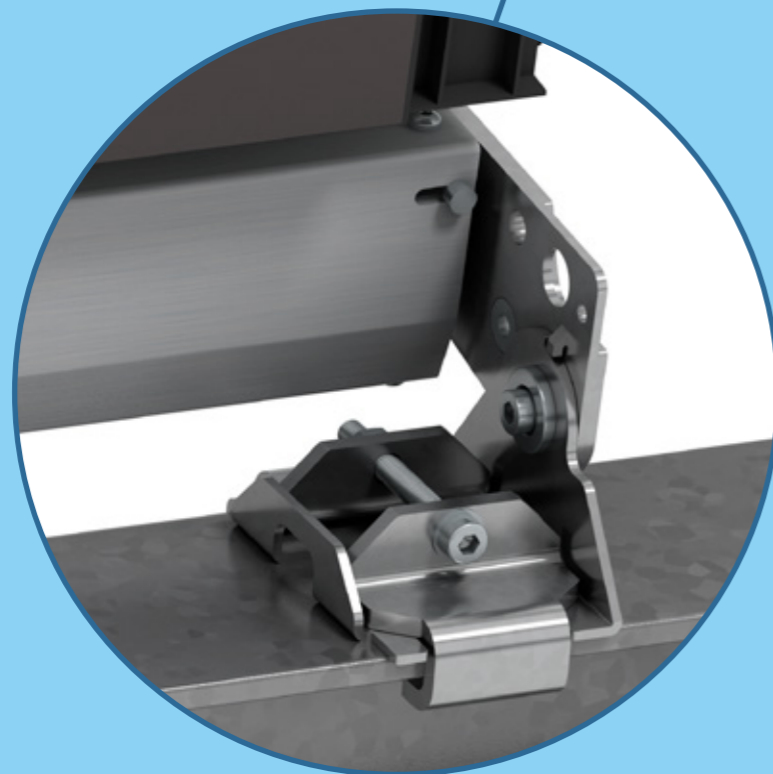
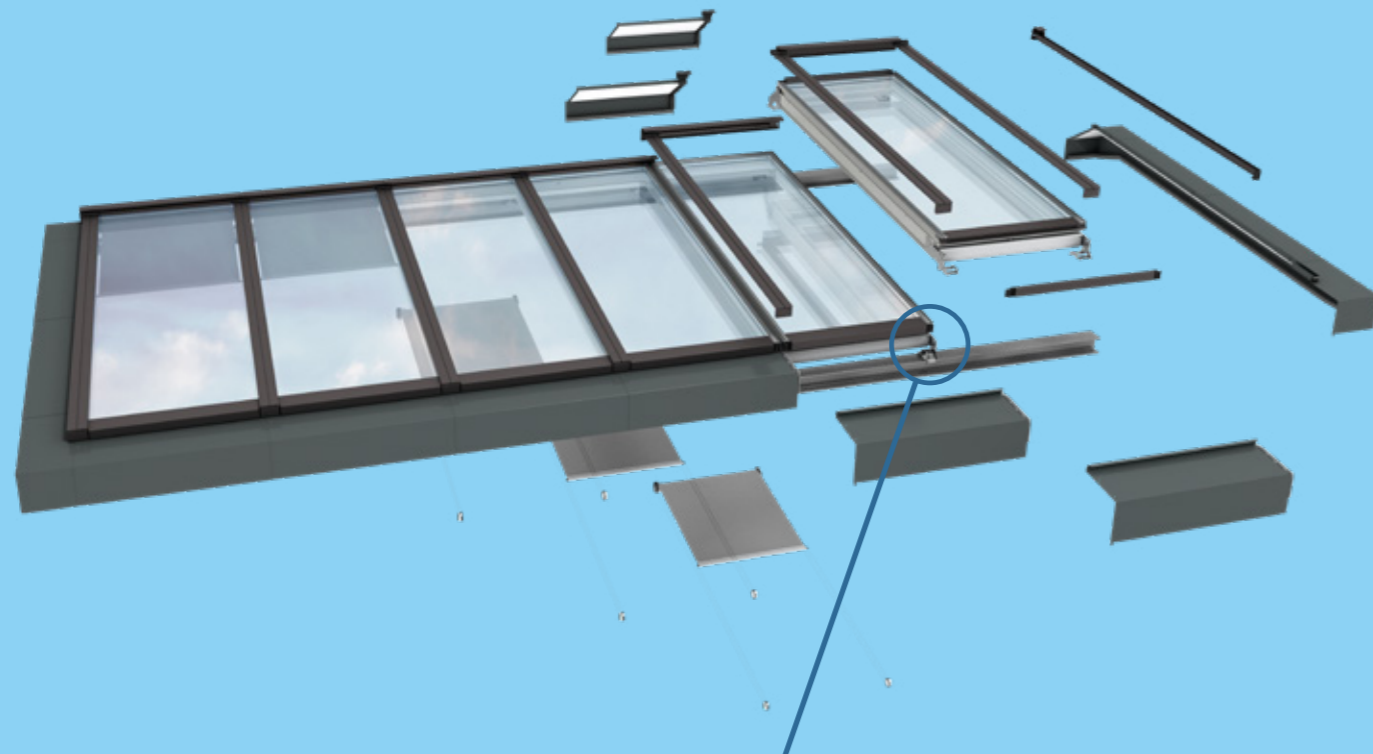

The fastest installation system



Up to 3 times faster installation*
*Than other rooflights. Proven by installers on construction sites

Shielding a building means protecting it against the dangers of weather, as well as, allowing work to commence inside the building. This makes speed a pivotal demand. Modular skylights support the fastest imaginable installation process, starting from delivery on the construction site to fastening the final screw.

On arrival, all items are marked with numbers and letters that clearly show the order in which the various components should be installed. Modules are hoisted directly from the pallets onto the prepared sub-construction and fastened within minutes. Final flashing and cladding is applied with prefabricated components, built to fit.



“It probably takes about 2 to 3 times longer with a traditional installation.”

John Wulff
 Tømrerfirmaet John Wulff A/S
 (Installer on Siemens Head Office, Denmark and DSV Headquarters, Denmark)



Brackets and clamps

The galvanized steel bracket and clamp system makes the fastening of the module quick, easy and hassle-free.



Top bracket for Ridgelight

The top bracket for Ridgelight 25-40° secures the opposing modules in the ridge to create a self-supporting construction.

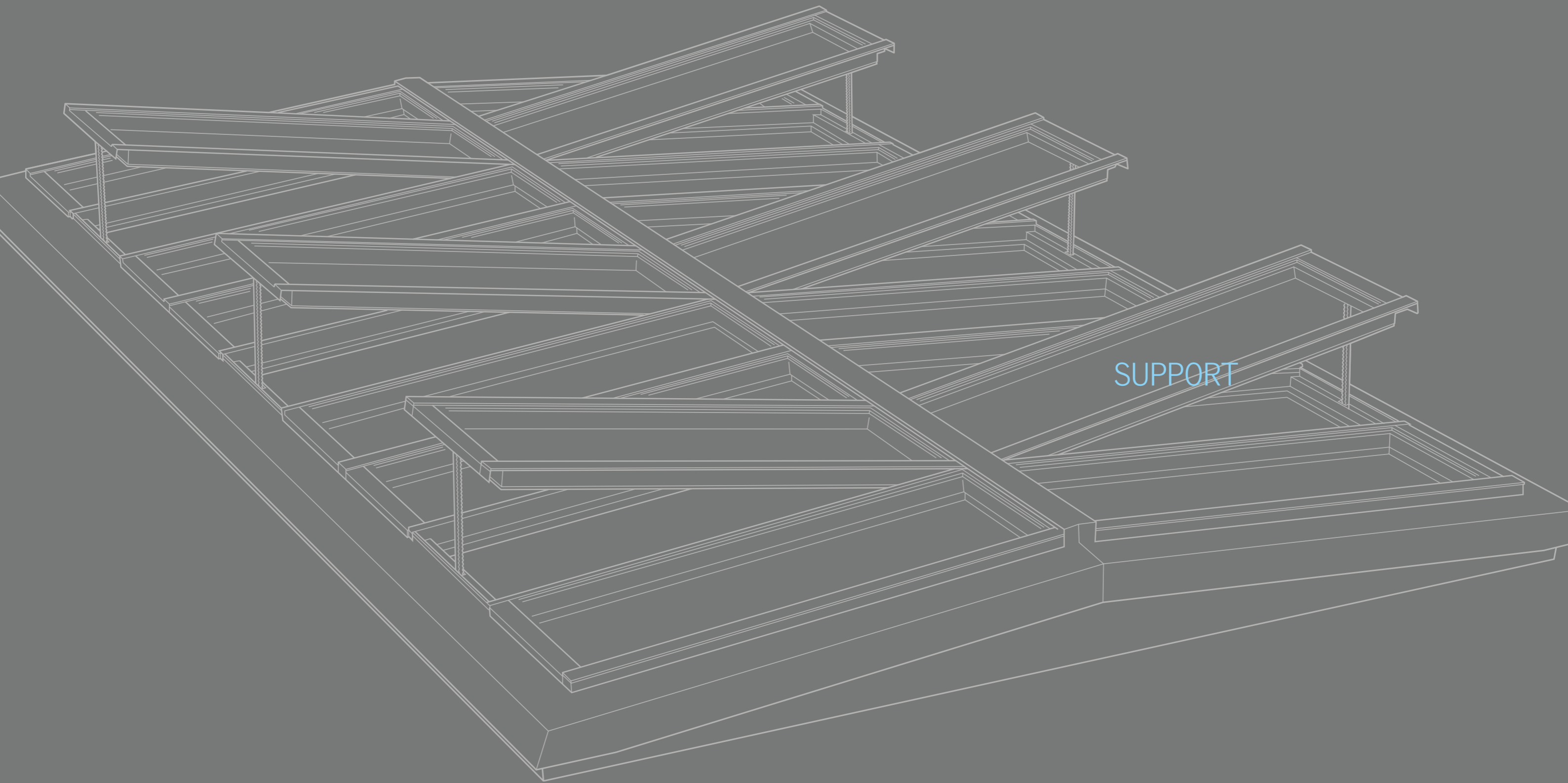

SUPPORT

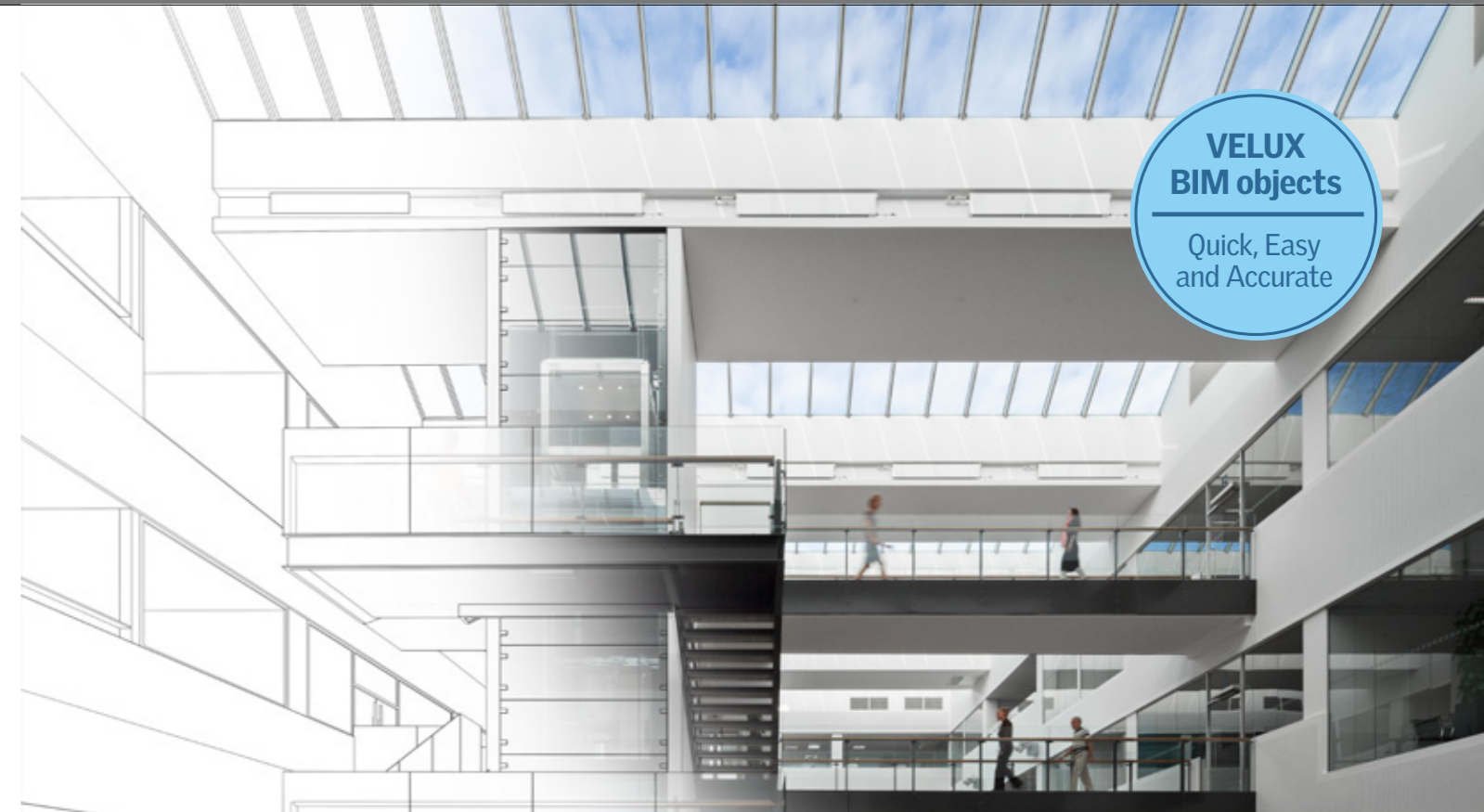
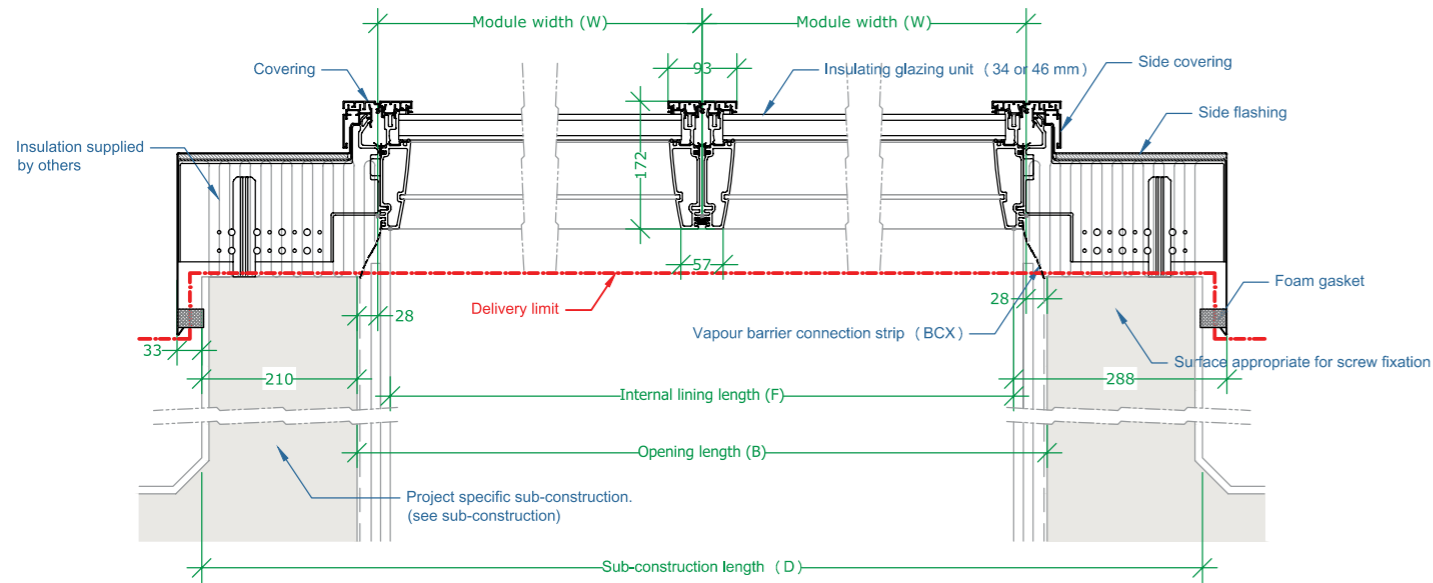

Download detailed 2D illustrations and technical drawings

Precise and detailed AutoCAD material can be downloaded for immediate use, directly from our website. The drawings contain all relevant descriptions and measurements.

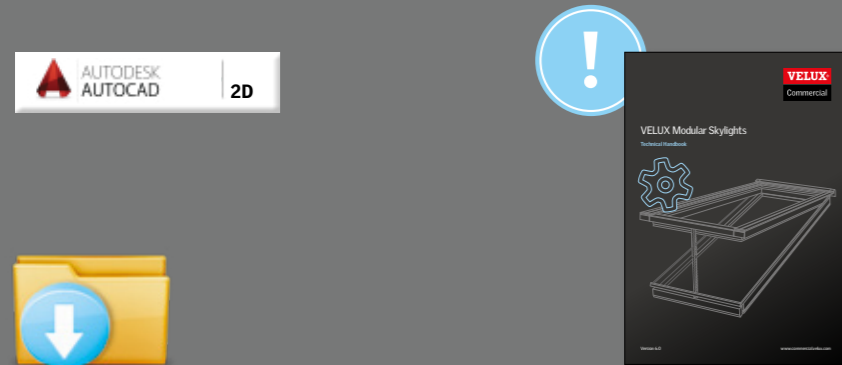

Download a complete folder with all material on modular skylights. Drawings can also be found in our Technical Handbook. The folder and handbook are also available for download on our product website listed below.

See more technical drawings in our Technical Handbook. Download it at: veluxcommercial.com

Go to the specification section of veluxcommercial.com

Use drag and drop objects

VELUX CAD/BIM objects are available for use with the most popular modelling programs. Furthermore, all 3D objects are compatible with Autodesk AutoCAD, Trimble

SketchUp and 3D Studio/3DS. The object families are built in accordance with buildingSMART, including: COBIE, CCS and Omni class.



Objects can be downloaded from international BIM libraries and from the VELUX website.



Go to the specification section of veluxcommercial.com

Sub-construction



To support an easy installation process, the sub-construction needs to accommodate the very specific system installation. Modular skylights require an accurate fixed-dimension substructure. Likewise, the strength of the sub-construction needs to be calculated from project to project, based on the building design and application size.

Thus, the sub-construction is not part of the prefabricated modular system.

Download our guide on sub-construction.

Download at veluxcommercial.com

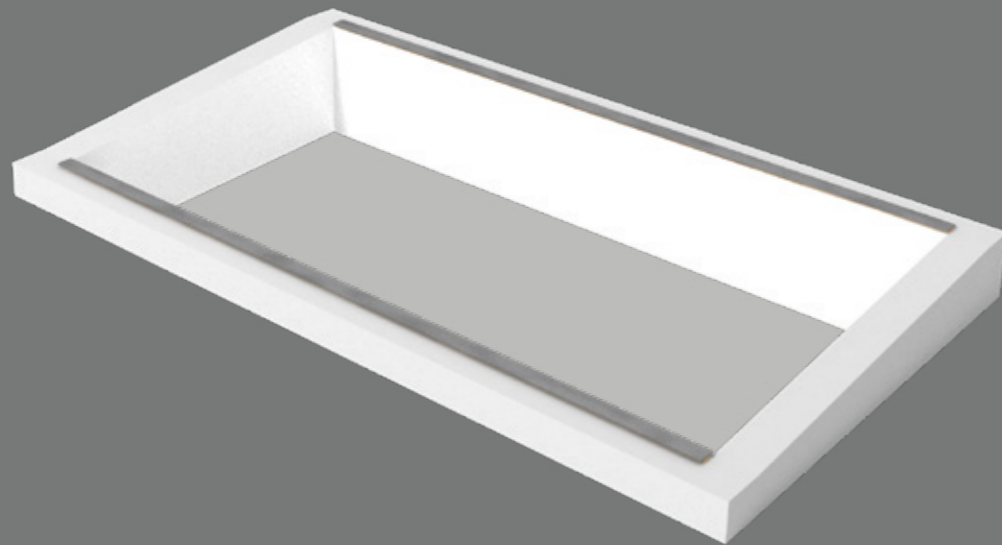

Read all about sub-constructions in the guides at: veluxcommercial.com

VELUX Daylight Visualizer

A professional tool for projects of all sizes

VELUX Daylight Visualizer is a professional simulation tool that offers precise and visually convincing daylight analysis of any given rooftop installation. The tool permits you to accurately simulate and quantify daylight levels in the interiors, develop before and after scenarios and create extensive data reports for project review. All projects can be imported or exported at will for further processing.

Comprehensive daylight planning is a prerequisite to achieving optimal daylight conditions in commercial buildings. Proper daylight management will always be an asset. For example, by replacing artificial light, you'll save electricity and by providing free solar heating, you'll save on conventional energy consumption.

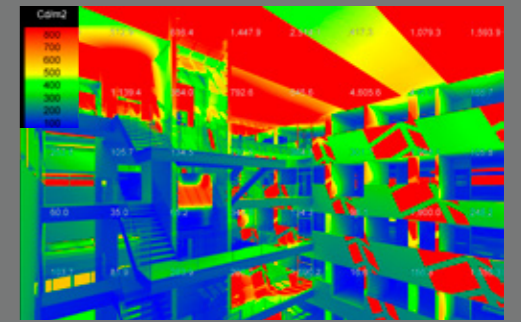
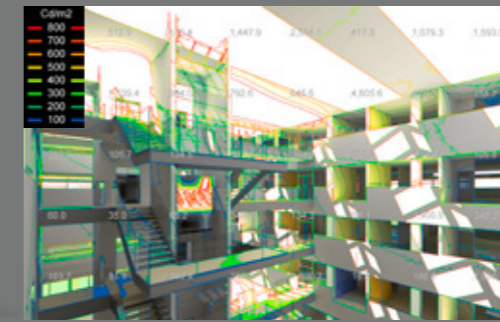

Design your own grand ideas – Create a magnificent skylight

Ready to know if your ideas can become a reality?

Let us calculate your possibilities and give a price estimate for your chosen solution.

Contact your local VELUX sales office for more details.

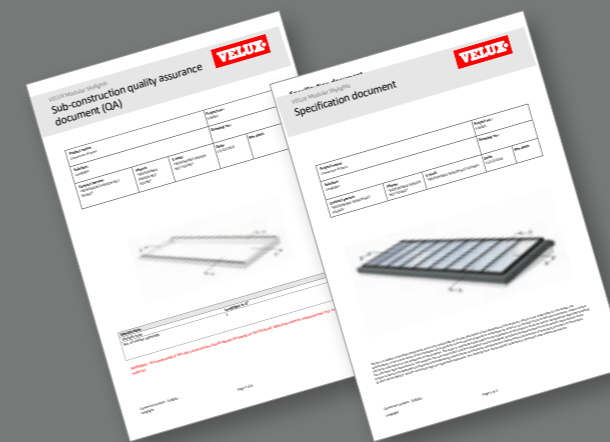

Sub-construction quality assurance (QA) document and specification documents

Design phase



Consultancy

To help you get started, we offer expert guidance even before your project gets approved.

Technical documentation

All technical documents are available for download on our websites.

Specification

Our experienced building consultants stand ready to help you specify your projects.

Installation phase



On-site support

Once your project is underway, we will help you track your progress and offer on-site consulting on projects and critical issues.

Instruction

To ensure high safety and efficiency on the construction site, we offer various forms of training for all installers involved. The training can take place directly on the construction site, where your project is being performed.



Daily operation



After sale

A number of tools and accessories are available to help optimise your solution, if or when the requirements evolve.

User guidance

To maximise performance output, it is sometimes necessary to educate the users about the properties of the solution and train elected employees, to operate the skylights.

Product service

Should the system, for some reason, require professional service, our team of VELUX service technicians will do all they can to solve the problem to everyone's satisfaction.



Guarantee



Our modular skylights and flashings are supported by a 10-year guarantee. Blinds, actuators and other electrical components that are a part of the modular system come with a 3-year guarantee. The guarantee is

subject to correct installation and usage.

Guarantee conditions can be found at: veluxcommercial.com

Contact



Our aim is to provide all the tools and answers to make your project as simple and trouble-free as possible. Thus, we offer a wide range of expert support and

consulting from before the project starts to well after its completion. To get in touch, please contact us here:

Address: VELUX Group
Ådalsvej 99, 2970 Hørsholm, Denmark
Email: vms@velux.com

VELUX Group
VELUX Commercial
Ådalsvej 99
2970 Hørsholm
Denmark

Email: vms@velux.com
Web: veluxcommercial.com
Blog: vms.velux.com

Bringing light to life

VELUX®

Commercial