



Report 2010

Laser Technology

Berlin-Brandenburg

WONDERFULLY BALANCED

Laser diodes –
precise and powerful

eagleyard manufactures laser diodes between 650 nm and 1,120 nm. An enhanced generation of tapered amplifiers at 780 nm and 850 nm is now available. Those compact and efficient semiconductor lasers achieve both excellent beam profile and highest output power up to 2 Watt.

eagleyard Photonics, headquartered in Europe's leading technology park in Berlin, Germany, is a fast growing and innovative player. From high power laser diode design to high volume production, eagleyard supports you every step of the way.

www.eagleyard.com



We focus on power.



Report 2010

Laser Technology

Berlin-Brandenburg

Front cover: Diode laser module from the Ferdinand Braun Institute, which converts wavelengths from the infrared to the visible spectral range by means of frequency conversion

Source: Ferdinand Braun Institute, Leibniz Institute for Highest Frequency Technology © FBH/schurian.com

This project of the TSB Innovationsagentur Berlin GmbH is aided by funds from the Investitionsbank Berlin, co-financed by the European Union – European Fund for regional development.

An Investment in your future!







Table of Contents

- 1 Introduction6**
- 1.1 Greeting6
- 1.2 Editorial7

- 2 Market and Industry Analysis8**

- 3 Analysis of Networking16**

- 4 History20**

- 5 Expert Interview24**

- 6 Laser Technology in Science and Industry29**
- 6.1 Foundations and Applications in Research30
- 6.2 Manufacturers and Suppliers34
- 6.3 Material Processing38
- 6.4 Measurement Technology and Analytics44
- 6.5 Medical and Biotechnology48
- 6.6 Information and Communication Technology52
- 6.7 Environment and Energy55

- 7 Industry Platforms58**
- 7.1 Networks and Transfer Organizations58
- 7.2 Laser Optics Berlin60

- 8 Literature62**

- 9 Imprint64**

Enclosure: CD-ROM
Contact information and profiles of companies and research organizations
Laser technology report as a PDF file

Harald Wolf
Mayor and Senator for Economy,
Technology and Women's Issues of
the State Berlin



1.1

Greeting



Due to its wide range of applications in science and industry, laser technology belongs to the most important focus areas in Berlin-Brandenburg's area of excellence Optical Technologies and Microsystems Technology (OT-MST). The companies in this industry are often market leaders in niches - a strength of the industrial location Berlin-Brandenburg.

This report provides an overview of the laser industry and, at the same time, emphasizes the enormous potential held by Berlin and Brandenburg in this technology field. The collaboration of the excellent research institutions in Berlin with innovative companies generates growth and qualified jobs. The economic region Berlin-Brandenburg is well positioned in our knowledge-based industrial society, not the least because of laser technology.

Despite the economical and financial crisis, optical technologies and microsystems technology achieve above-average growth figures. Other regional areas of excellence also benefit from this positive development, since both are enabling technologies and - as such - can be found in almost all application areas.

The close networking of companies and research institutions is paying off. Many companies are spin-offs from research institutions, such as the Ferdinand Braun Institute, and are now independent and quite successful in the OT-MST industry. They provide new jobs and strengthen the excellent reputation of the Capital Region as a location for business and innovation.

Optical Technologies and Microsystems Technology continue to grow in Berlin and Brandenburg. The high density of industry players is a perfect basis for a mutual transfer of know-how between science and industry.

Harald Wolf



Dr. Adolf M. Kopp
Managing Director
TSB Innovationsagentur
Berlin GmbH (l.)

Prof. Dr. Eberhard Stens
Division Manager
Optical Technologies -
Microsystems Technology
TSB Innovationsagentur Berlin
GmbH (r.)

Editorial

1.2

In 1960, a technology promised to change the world. It was thought to soon be capable of healing eyes, transmitting signals, processing material, measuring pollution in the atmosphere, or even igniting nuclear fusion. In the 1960s, the completion of the first laser was considered as the greatest development in solid state physics since the transistor and it has since paved the way for a multi-billion industry.

Many of the visions of those days are reality today. Laser technology is a key technology which has established itself in many industries and is developing extremely well in Berlin-Brandenburg.

It holds an important position as a strategic focus area within the area of excellence Optical Technologies – Microsystems Technology, and it contributes significantly to the sustainable development of the industrial location Berlin-Brandenburg.

The key to the success of the region is the strong research environment with its close connections to local industry. Over the past years, a variety of network structures have been formed in the Capital Region. They grant companies and research facilities access to resources such as knowledge or capital, both on the local and the global level.

This report, "Laser Technology in Berlin-Brandenburg", is part of the strategic development process and it will, for the first time, give a quantitative and qualitative overview of this sector of industry in the Capital Region and contribute to greater transparency, both internally and externally.

Dr. Adolf M. Kopp

Prof. Dr. Eberhard Stens



(Image) Source: Heike Rusch

Gerrit Rössler

2.0

Market and Industry Analysis The Berlin-Brandenburg Focus Area Laser Technology by the Numbers

The following two chapters provide an overview of the industry structure and economic development of laser technology in Berlin-Brandenburg. Their basis is provided mainly by surveys of the TSB Innovationsagentur Berlin GmbH conducted in 2010.

Data Collection Methods

The calculations in the following chapter are based primarily on a survey of sales and employment figures from commercial databases. This is due to the fact that official government statistics don't cover small businesses sufficiently and the classification of the economic sectors of the industry examined here is not applicable. The primary source is the MARKUS database, managed by Bureau van Dijk Electronic Publishing with the Association of Organizations for Creditreform. It includes structural, financial and participation data of 1.2 million companies registered in the German trade register.

Where possible, data gaps were filled using primary data from individual interviews.

When no data could be collected, zero growth was

assumed. As a result, the growth rates presented here tend to lie rather below the actual values (positive as well as negative values).

The industry figures include only companies in the manufacturing sector. Service and retail businesses are not taken into account. For internationally operating companies with multiple locations only the employees in Berlin-Brandenburg and their added value were included in the calculations.

In January 2010, the TSB Innovationsagentur Berlin conducted a standardized survey among 61 companies in laser technology in Berlin-Brandenburg. 31 companies participated, corresponding to a response rate of 51%. Nominally, these 31 companies represent 49% of the industry, but provide 54% of the employees and 72% of the industry's turnover.

The analysis of the survey provides primary data on investment and export shares as well as estimates of the future development of the companies and the importance of individual sales and procurement markets.

Industry Structure

Overall, 64 companies in Berlin-Brandenburg were assigned to the manufacturing sector of laser technology. 12 companies actually manufacture lasers. The other companies are active in upstream and downstream industries, and are predominantly suppliers of components or systems developers. The proportion of small and medium-sized businesses with fewer than 250 employees amounts to 97%. 94% have less than 50 employees and therefore belong to the small business category.

Most of the survey participants assigned themselves to the application fields material processing and measurement technology & analysis. Medical technology, biotechnology and transport & mobility are also strongly represented. The results underline the importance of laser technology as an enabling technology for the areas of excellence in Berlin-Brandenburg (see Figure 1).

Application Fields of Laser Technology Companies in Berlin-Brandenburg

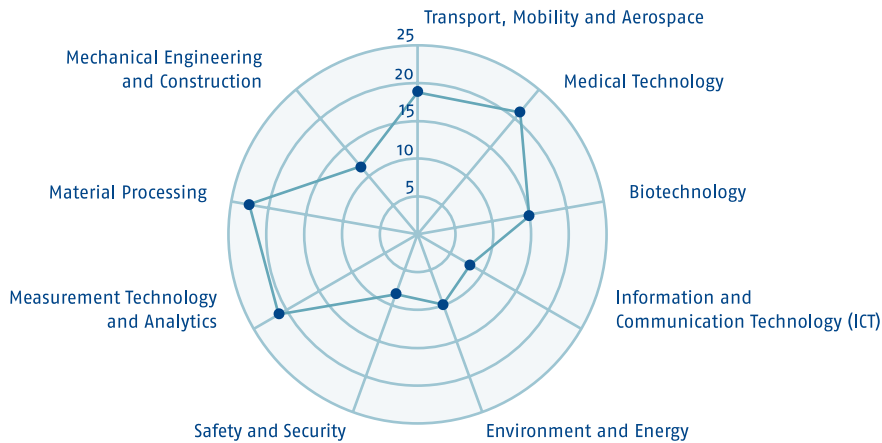

Source: TSB Innovationsagentur Berlin GmbH 2010



Figure 1

Turnover and Employment Development

Turnover of the Berlin-Brandenburg companies rose from 197 million Euros in 2004 to 285 million Euros in 2008 (see Figure 2). The strongest annual growth of the industry was achieved in 2006 with 19.9% (2005: 9.6%; 2007: 7.7%). With the development of the approaching financial and economic crisis, the annual growth rate declined to 2.2% in 2008. Based on the available sales figures for 2009, a decline in sales of approximately 8% to 265 million Euros is predicted for that year. According to the forecasts made by the companies as part of the survey, the industry will recover in 2010 and even exceed the result of 2008 with approximately 290 million Euros. The value for 2010 is based on information from the companies on the expected percentage growth. It serves as the basis for the extrapolation of the absolute growth, based on the available sales figures.

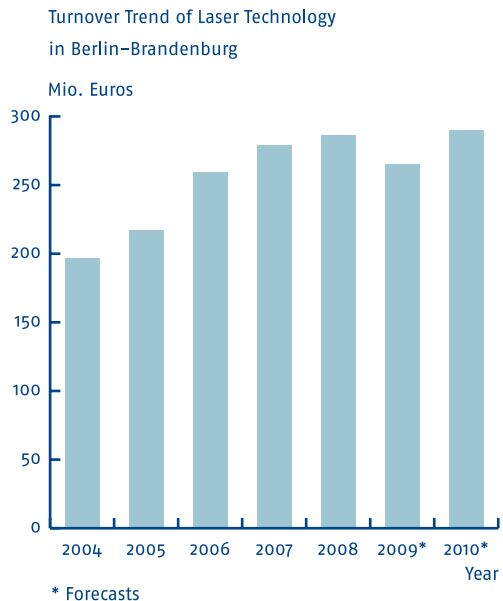

* Forecasts
Source: TSB Innovationsagentur Berlin GmbH 2010

Figure 2

Legend for box plots

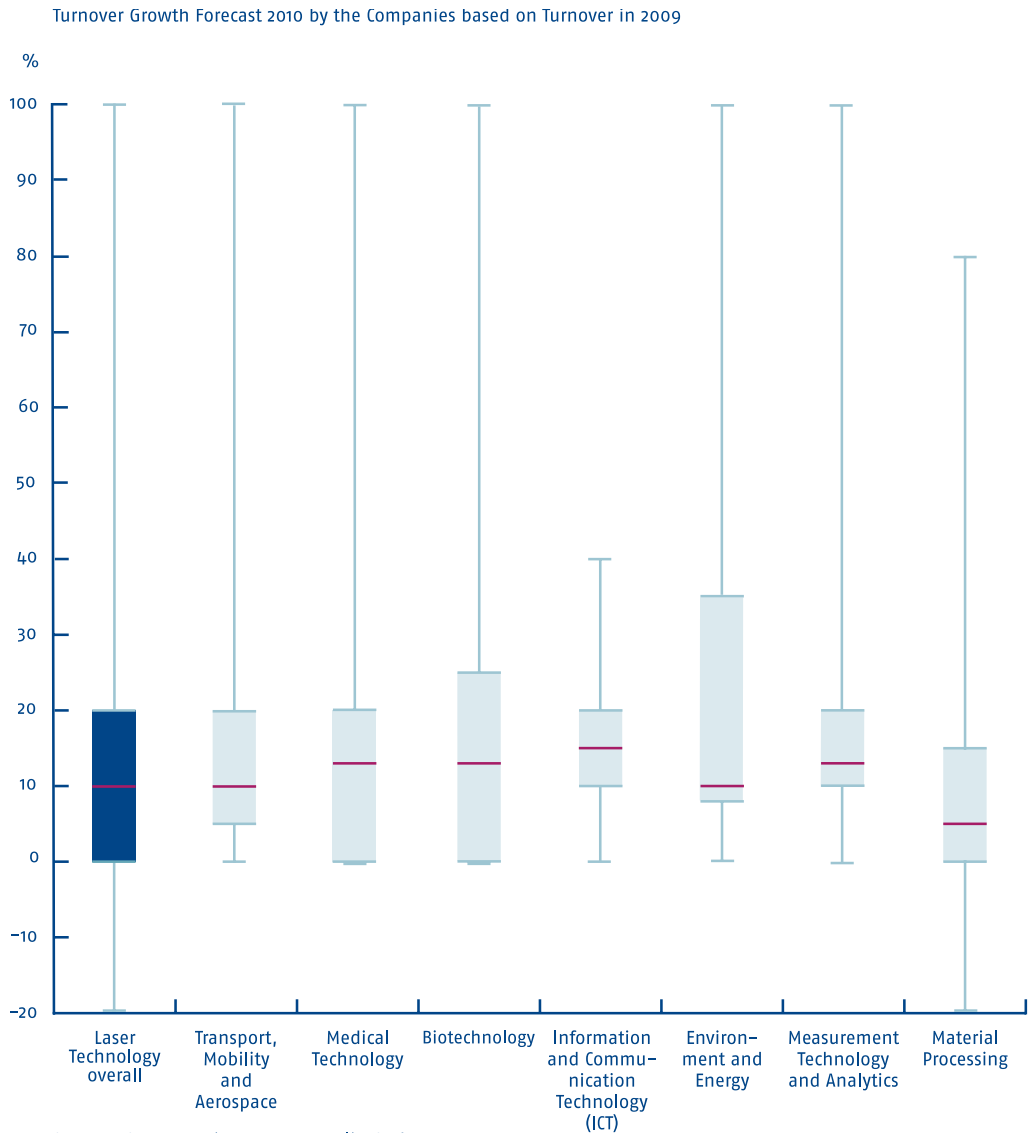
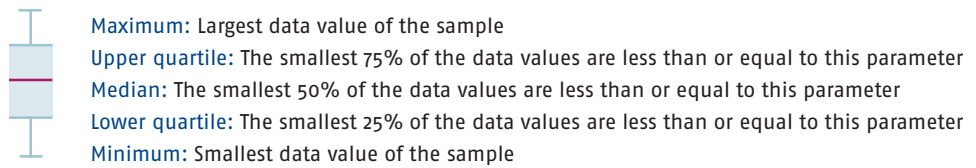
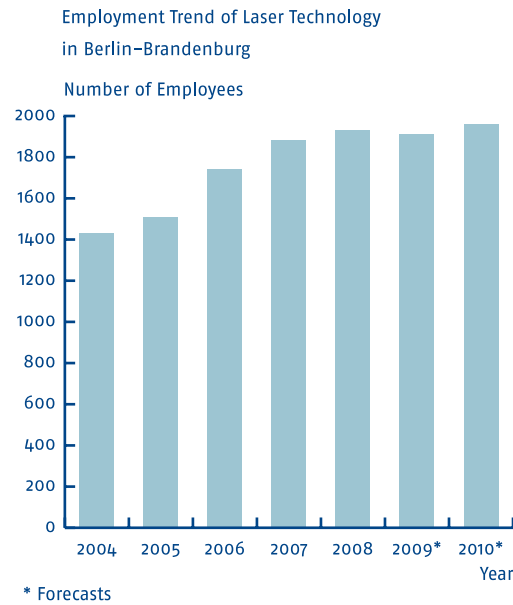

Figure 3 Source: TSB Innovationsagentur Berlin GmbH 2010

The result of a purely quantitative analysis of the data on the estimated growth in 2010 is a median of 10% sales growth for the entire industry (see Figure 3). With 15%, the median among the manufacturers of laser technology applied in information and communication technologies (ICT) is the highest, followed by medical technology, biotechnology and transport & mobility with 13% each. Material processing has the lowest median value of 5%.

Employment figures showed a similar development. The number of employees in the companies in Berlin-Brandenburg rose from 1,430 in 2004 to 1,930 in 2008 (see Figure 4). Again, the annual growth reached its peak in 2006 with 14.6% (2005: 5.6% 2007: 8.7% 2008: 2.7%). The impact of the rising crisis is weaker in the employment field. For 2009, a decrease of only 1% to 1,910 is predicted, whereas the companies also expect a total of 1,960 employees in 2010, i.e. more than in 2008.



Source: TSB Innovationsagentur Berlin GmbH 2010

Figure 4

The companies estimated employment trends rather homogeneously (see Figure 5 – one outlier with an expected increase of 100% was not represented in the chart). ICT, measurement technology & analysis and transport & mobility show the highest values with an average (median) of 5% each.

Average turnover per employee increased from 138,000 Euros in 2004 to 148,000 Euros in 2008.

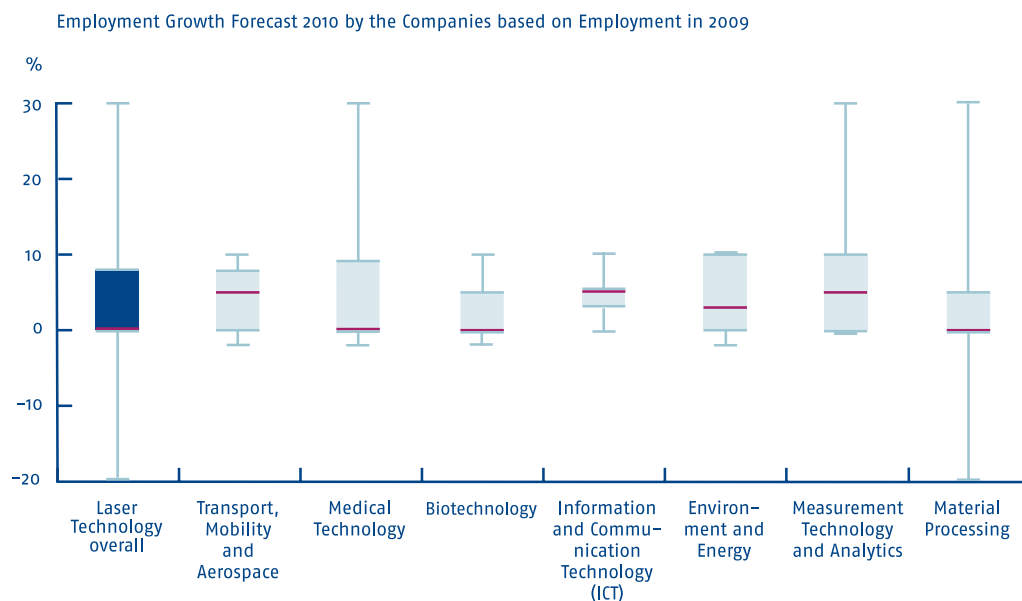

Source: TSB Innovationsagentur Berlin GmbH 2010

Figure 5

Impact of the Financial and Economic Crisis

As the key figures on turnover and employment trends indicate, the financial and economic crisis has not failed to leave its mark on the companies in Berlin-Brandenburg. 48% of the survey participants have described the impact on their businesses as "strong" or "very strong" (see Figure 6). The worst affected sector is material processing: 55% evaluate the impact as "strong" or "very strong". The sectors severely hit by the crisis, such as engineering or the automotive industry, strongly influence the order figures of the suppliers from upstream industries, e.g. laser technology. As a result, the suppliers suffer a significant decline in turnover.

Least affected by the crisis were companies in the information and communication technologies sector. 50% describe the impact as "light" or "very light".

However, at the time the business survey was conducted, signs of a recovery were already visible. Only 17% rate their current business situation negatively. 45% define their situation as "good" or "very good" (see Figure 7). With 58% and 53% positive ratings, the sectors measurement technology & analytics and transport & mobility have the best perspectives

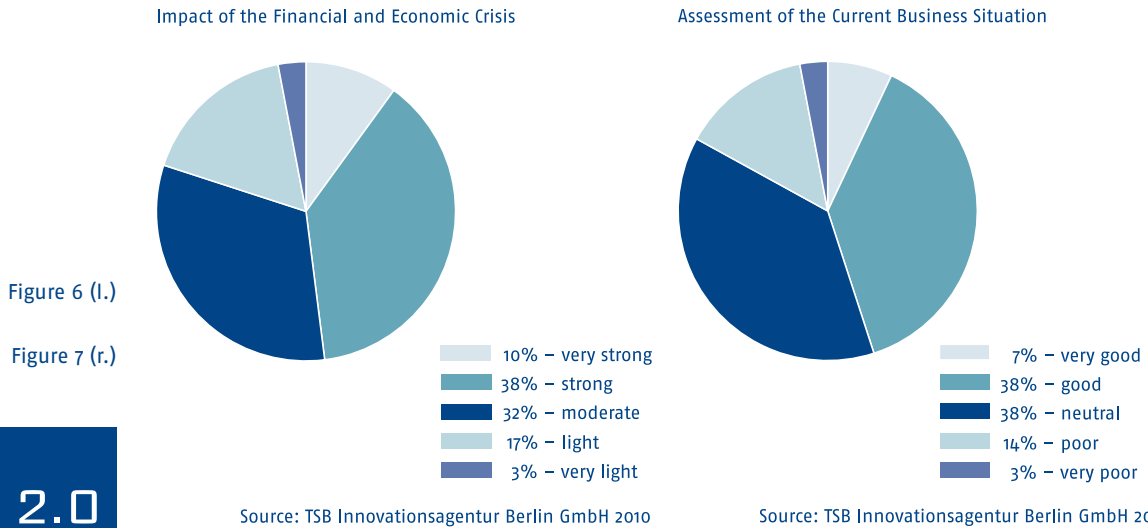

Figure 6 (l.)
Figure 7 (r.)

2.0

Investment and Export

Analogous to the high growth expectations for turnover and employment, the ICT sector is also leading in the share of expenditure for research and development measured by turnover with a median of 20% (see Figure 8). Other research-intensive application areas are environment & energy and transport & mobility with 18% each. With an average of 10%, companies in measurement technology & analytics spend the least on R&D.

Overall, laser technology in Berlin-Brandenburg invests 15% of turnover and, therefore, exceeds the average of other sectors. In comparison, the whole optical technologies – microsystems technology industry in Berlin-Brandenburg has an R&D rate of approximately 8% (see TSB 2008a).

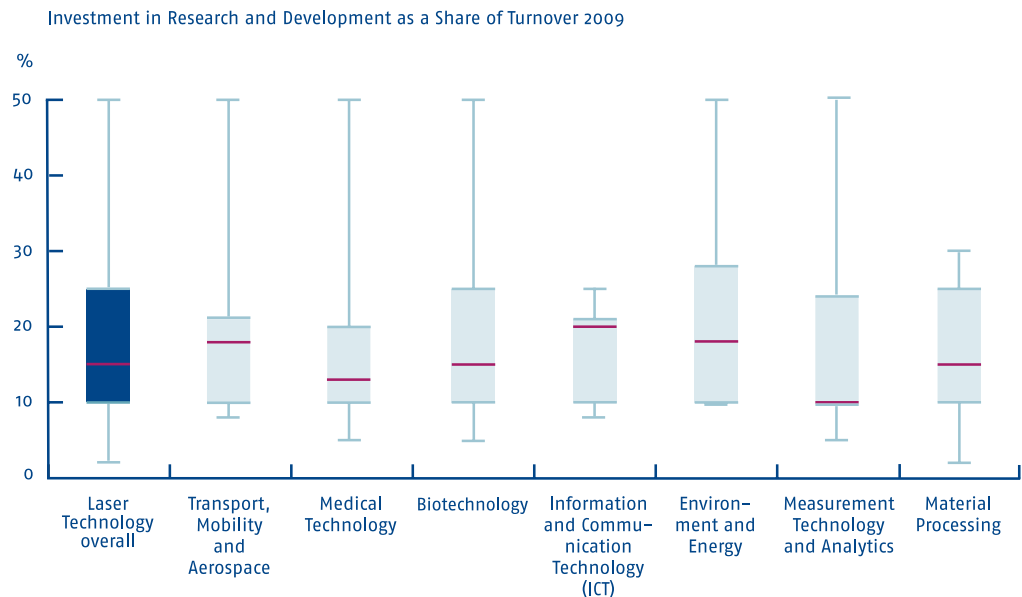
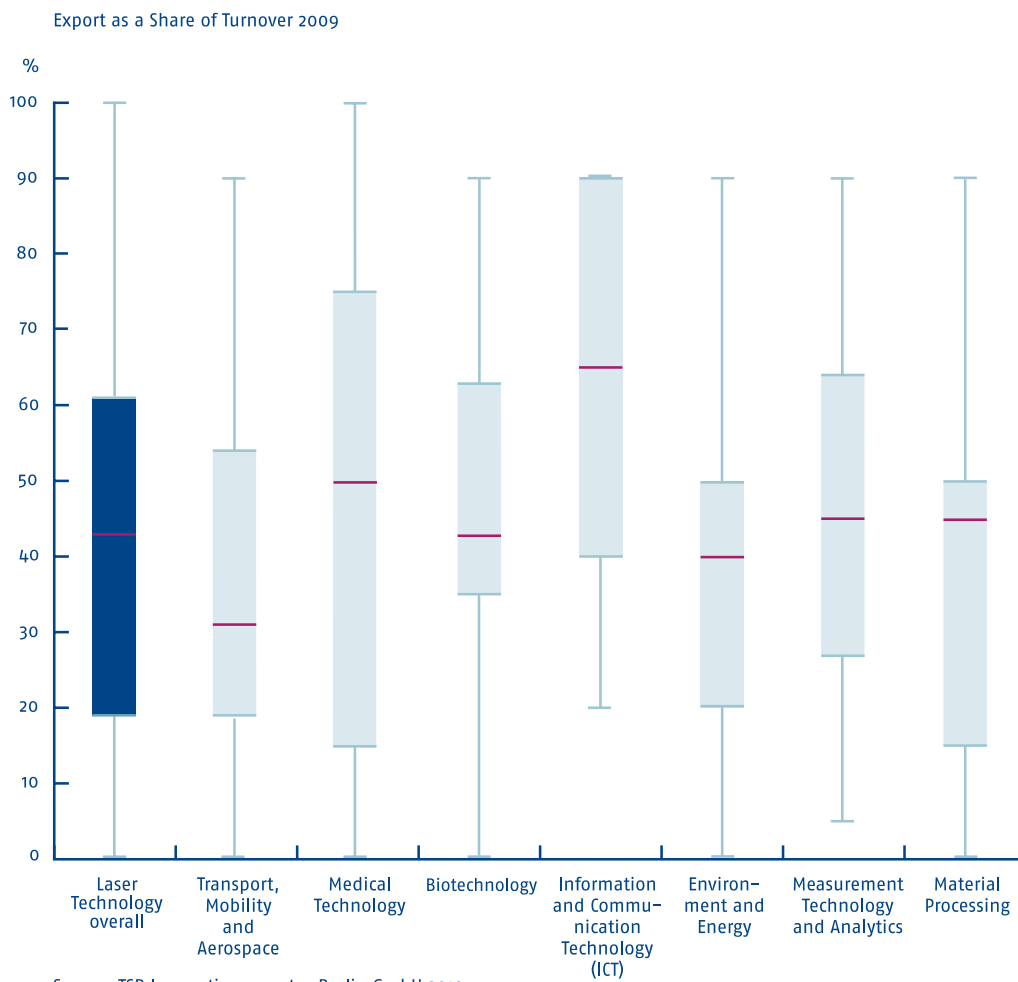

Figure 8

If one relates the percentage figures from the survey to the turnover data for individual companies and extrapolates to the whole industry sector, one arrives at a total annual investment volume of about 38 million Euros.

The average export fraction is 43%. Some companies produce exclusively for either the export or the inland market (see Figure 9). The most export-oriented sectors are ICT with a 65% fraction, and medical technology with 50%. With average fractions of 31% and 40% respectively, the sectors transport & mobility and environment & energy are more focused on the inland market, explained partially by the fact that they are represented by many large-scale enterprises (OEMs) in Berlin-Brandenburg (see, TSB and TSB 2008b, 2008c) and, therefore, generate a high demand in upstream industries such as laser technology.



Source: TSB Innovationsagentur Berlin GmbH 2010



Figure 9

Sales and Procurement Markets

Figure 10 provides an overview of the companies' assessment of geographic sales and procurement markets. Key sales markets are Germany, Western Europe and Asia. Asia, Western Europe and also North America will gain further importance in the future. Surprisingly, the companies see Asia primarily as a sales market and less as a procurement market for cheap components, as one might suspect at first. A rather low potential is seen in Eastern Europe, both in terms of sales and buying.

The most important procurement markets are found in the German-speaking area. 86% declare Germany to have a great importance as a procurement market, and 48%, i.e. almost half of the companies, declare this in Berlin-Brandenburg. No major changes of these structures are expected in the next few years; only 26% of the survey participants expect Asia to possibly attain greater importance in the future. Also noticeable is the fact that both in Berlin-Brandenburg and in the entire Federal Republic Germany is seen largely as a procurement market. A possible reason for this might be that supplier relationships in high-tech with their innate complexity might be managed more easily in a legally and culturally homogeneous system.

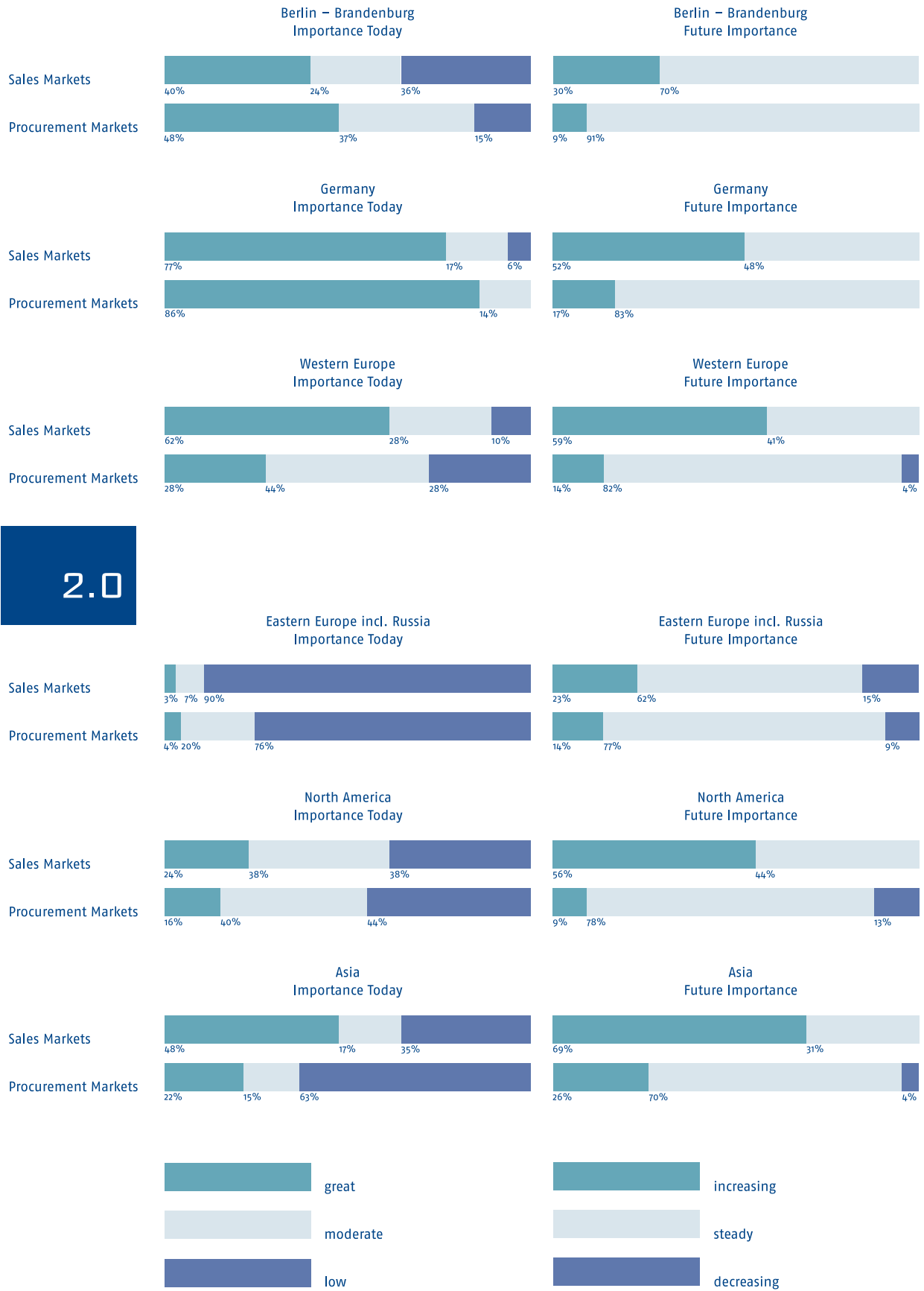

Figure 10 Importance of Geographic Sales and Procurement Markets

Source: TSB Innovationsagentur Berlin GmbH 2010

In particular, the relationships between companies and universities and research facilities fit into this domain. Therefore, specific research competencies are important factors for choosing the location of a company. Short distances facilitate the transfer of technological know-how and provide a great site advantage, especially for companies in Berlin-Brandenburg. The Science and Technology Park Berlin-Adlershof is an excellent example, but Schöneweide and Potsdam are also among the most important locations for laser technology in Berlin-Brandenburg (see Figure 11).

The following chapter provides a more detailed overview of the networking of regional industry players in laser technology.

Laser Technology Science and Industry Sites in the German Capital Region Berlin-Brandenburg

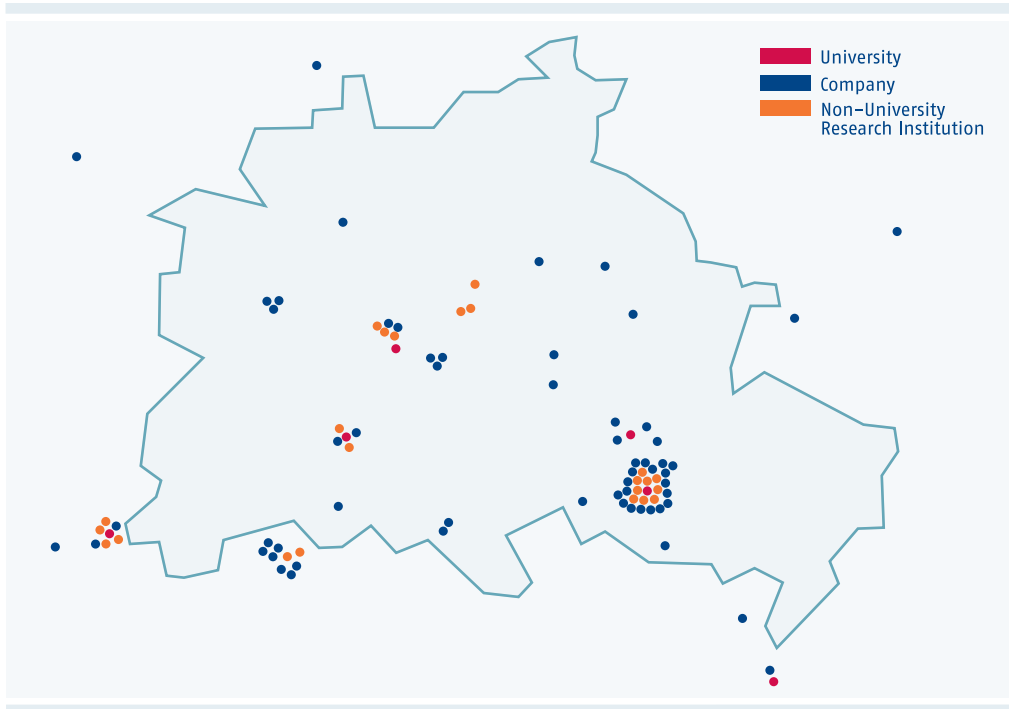

Source: TSB Innovationsagentur Berlin GmbH 2010



Figure 11

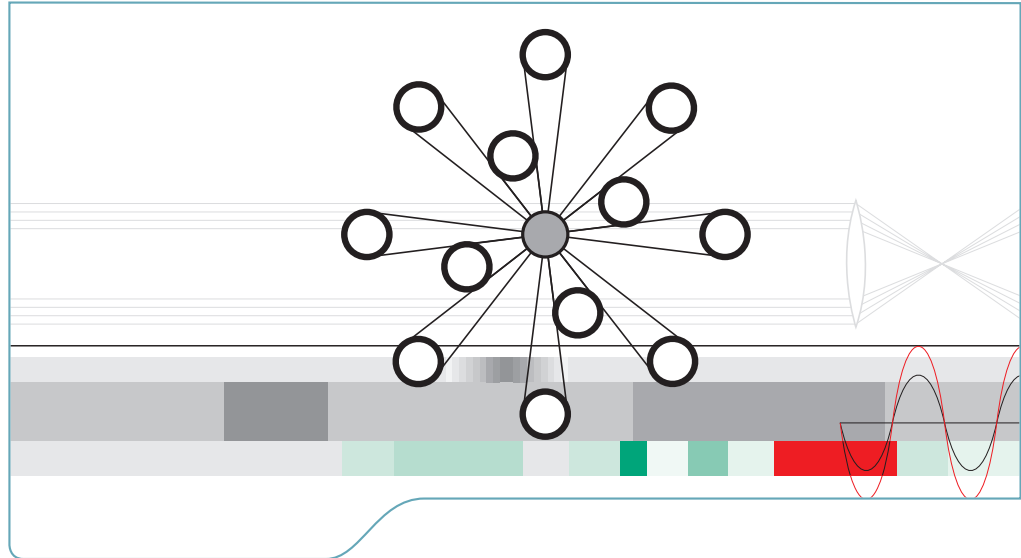

(Image) Source: Heike Rusch

Dr. Frank Lerch

3.0

Analysis of Networking in the Laser Technology Area

Laser Technology in Berlin-Brandenburg – Relationships, Value Added, and Patents

Networking is not only on everyone's lips, but, in the case of laser technology in Berlin and Brandenburg, actually lived. Initially, networks consist of nodes (for example individuals, organizations or events) and edges, such as effects or social relations. When not only the structures of a (social) network are of interest, but also the mechanisms of the organization of activities, questions regarding the management of inter-organizational relationships arise. One then speaks of the governance of networks.

Laser technology in Berlin has a long tradition of mutual exchange and networking. Already more than 90 years ago when the theoretical basis for laser technology was created in Berlin, and later when the first lasers were built in the divided Berlin, networking played an important role. This tradition is still cultivated today and is reflected in initiatives such as OpTecBB, PhotonikBB or the Laser Association (Laserverbund), as well as in numerous business exchange relationships, research and development relations or personal relationships.

Thus there is a relatively close network of communicative and cooperational relations between the industry players in laser technology in the Capital Region.

According to a survey taken by the TSB Innovationsagentur Berlin in early 2010, slightly more than half of the main cooperation partners are located in the Capital Region (~ 53%). About one-third of the main

cooperation partners is located in the rest of the Federal Republic. There are numerous connections to Thuringia, Baden-Wuerttemberg and Bavaria. The most important international partners are located in the U.S., Korea, China and Japan. Consequently, laser technology in Berlin-Brandenburg has a larger national and international focus than the optical technologies industry in the Capital Region as a whole. The strong presence of relationships with regional key partners is also an indication of the advantage of short distances for transactions and the innovation process in the regional cluster of optical technologies. Regional research facilities are particularly important for industry players in laser technology. They provide easy access to strategically important external knowledge due to their geographic, cultural and cognitive proximity. There are also a number of innovative regional component suppliers which regional system manufacturers can consult. Some of the research facility partners considered as the most important in laser technology in Berlin are the Fraunhofer Institute for Telecommunications, Heinrich-Hertz-Institute, the Ferdinand Braun Institute, Leibniz Institute for Highest Frequency Technology and the Technical University of Berlin. Companies deemed important are, for example, eagleyard Photonics GmbH, FiberTech GmbH, Jenoptik Diode Lab GmbH, or IBL Innovative Berlin Laser GmbH.

The network of industry players in the field of lasers was recently surveyed by the TSB Innovationsagentur based on a questionnaire and analyzed and graphed by NRC Network Research & Consulting with means of analysis and presentation commonly used in studies of networks, UCINET and NETDRAW (two statistical software tools). Initially, the overall structure of the network of connections is evaluated, and central and peripheral industry players are differentiated. Figure 1 shows an example of an ego-centric network (the figure is anonymized and shows the status as of March 3, 2010). The blue nodes represent companies, the orange nodes non-university research institutions and the red nodes universities. The size of the nodes represents the size of the organization in the location Berlin-Brandenburg, measured by turnover or budget. Finally, the thickness of the lines represents the intensity of the re-

lationship between two players, measured by the frequency of contacts between the organizations.

figures are often perceived as the "most important" figures in a network. In the context of the current analysis, centrality is defined as control over information and resource flows. These monitoring options give key industry players a certain power within the network and, at the same time, also form information, knowledge and resource distribution nodes in the network. Key players in the laser technology network of Berlin-Brandenburg are, in the order of importance, the Ferdinand Braun Institute, Leibniz Institute for Highest Frequency Technology (FBH), Berliner Glas KGaA Herbert Kubatz GmbH & Co., Max Born Institute for Nonlinear Optics and Short Pulse Spectroscopy (MBI), Photon AG, IBL Innovative Laser GmbH Berlin, German Aerospace Center (DLR), Laser- and Medical Technology GmbH Berlin (LMTB), Brandenburg University of Applied Sciences, the Technical University of

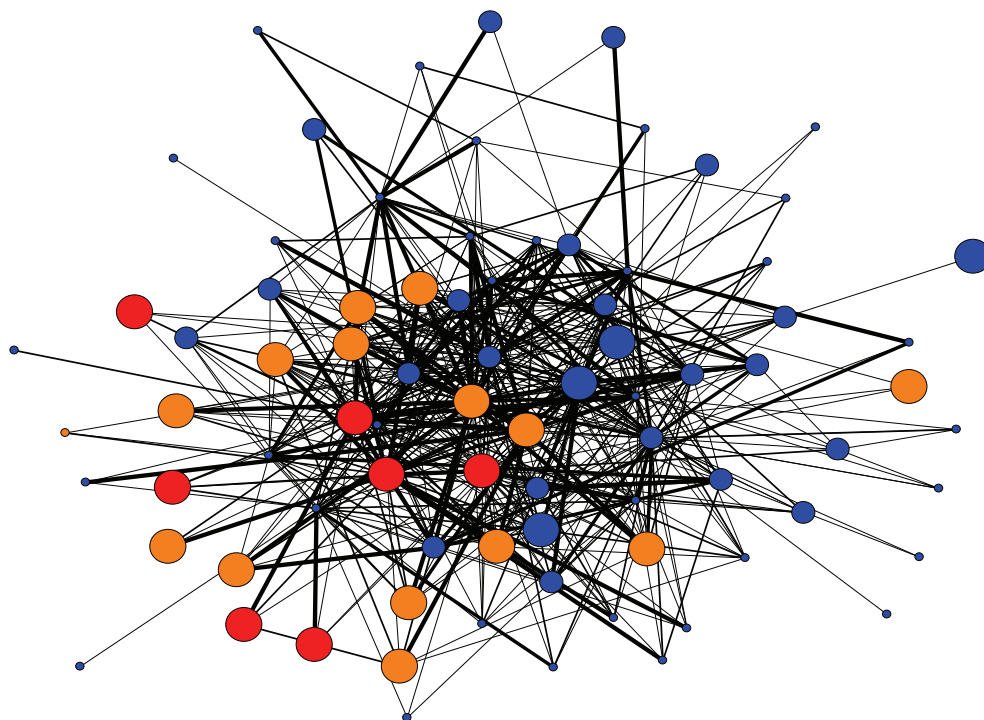

3.0

Figure 1
Network of the Industry Players
in Laser Technology in Berlin-
Brandenburg

Source: TSB Innovationsagentur Berlin GmbH / NRC Network Research & Consulting UG 2010

lationship between two players, measured by the frequency of contacts between the organizations. The overall structure of the network of connections reveals an extensive mix of companies and research institutions. It is noticeable, that the microenterprises (turnover ≤ 2 million Euros) are predominantly situated in the periphery of the network. Also, their relationships maintained with other network players tend to be less intense than those by the small (turnover ≤ 10 million Euros) and medium-sized (turnover ≤ 50 million Euros) businesses or research institutions.

The evaluation of the available data allows statements about the key players in the network. Central

Berlin, Frank Optic Products GmbH, Fraunhofer Institute for Telecommunications, Heinrich Hertz Institute (HHI), Newport Spectra-Physics GmbH, eagleyard Photonics GmbH, Fraunhofer Institute for Reliability and Microintegration (IZM), Technical University of Applied Sciences Wildau, and Jenoptik Diode Lab GmbH. It is often assumed that companies in regional clusters and networks purchase primary products from each other and re-sell their products and services to regional companies. This is referred to as production along a supply chain. Regardless of a possible regional integration, the supply chain of laser technology can be divided into the stages input materials, components, systems and products (see Figure 2).

The supply chain begins with primary products and services supplied by adjoining industries. Among the available materials are, for example, gases, fiber glasses, coatings or crystals. The next stage of the supply chain includes components such as optical components, fiberglass components and laser rods. These components are integrated into systems such as solid, gas or diode lasers or into beam guidance systems. Such systems are partly combined with other systems and further processed into end-products such as laser materials processing machines, quality testing equipment or medical lasers. These are then offered to customers in various markets (e.g. industrial manufacturing, research, etc.). Typically, the supply chain stages and the entire supply chain are embedded in a supporting infrastructure in the technological (e.g. educational institutions, (non-)university research facilities or service providers such as patent agents or technology parks) and

commercial (e.g. associations, investment communities, dealers and distributors) dimension. Almost all stages of an ideal-typical laser supply chain are represented in the region Berlin-Brandenburg by at least one, and often by two or more organizations (see Figure 2). The probability of the existence of complete interconnected supply chains in a certain region is very low in the high technology field. On the one hand, manufacturers of state-of-the-art components, systems and products have to buy primary products from specialized suppliers of which there are often only a few or even just one on the globe, and, on the other hand, re-sell the components, systems and products to customers around the world. There are definitely supplier and customer relations in the field of laser technology in Berlin and Brandenburg. The question whether or not there are in fact complete supply chains in the region could not be answered conclusively.

Figure 2
Laser Supply Chain Stages in Berlin-Brandenburg

Source: TSB Innovationsagentur Berlin GmbH / NRC Network Research & Consulting UG 2010

3.0

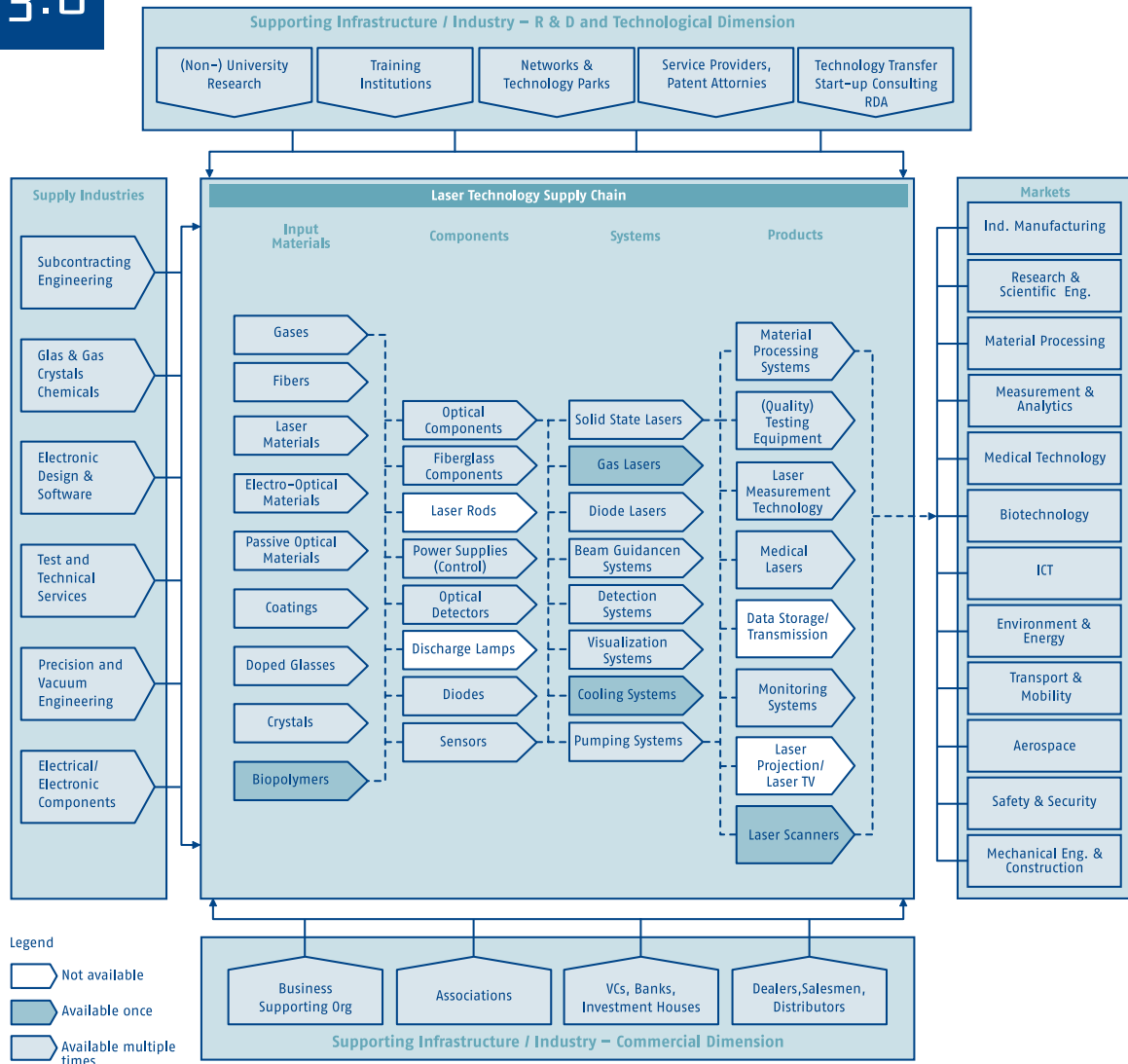

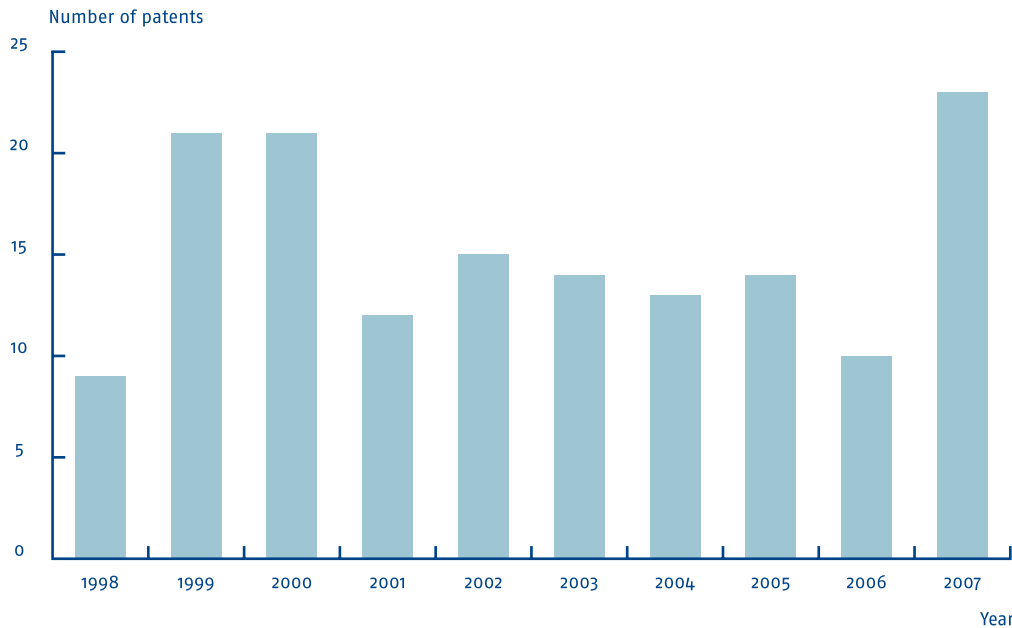

Figure 3
Successfully Registered Patents
of Laser Companies in Berlin-
Brandenburg

Source: TSB Innovationsagentur
Berlin GmbH / NRC Network Research
& Consulting UG 2010

Figure 2 does, however, also indicate that most stages of the laser supply chain in Berlin-Brandenburg are represented by more than one company. Especially in the field of input materials and components, many companies are found at each stage. For example, Lumics GmbH offers pumped laser chips, Crystal GmbH offers diffusion welded crystal components, Fibertech GmbH offers multimode quartz fibers, special fibers and coatings, and Frank Optic Products GmbH offers fiber-optical components (just to name a few). Furthermore, laser companies in Berlin and Brandenburg integrate the components purchased partially in the region into systems. Gas or solid state lasers are regionally manufactured by companies such as LTB Lasertechnik Berlin GmbH or IBL Innovative Laser GmbH Berlin. There are also manufacturers who offer their products as OEM or turn-key solutions – for example Compact Laser Solutions GmbH and Laser-Mikrotechnologie Dr. Kieburg GmbH in the field of laser material processing, or Secopta GmbH in the field of laser optical analytical systems. However, no large system integrators and mass producers of laser systems are located in the region. Instead, many manufacturers have focused on niches and are often world market leaders.

To continue to meet this high standard, some companies reinvest significant fractions of their total turnover in research and development and maintain close contacts with (regional) research institutions. Registered patents can be used as an indicator of research intensity and innovativeness of businesses. An analysis of the patents registered by laser companies in Berlin and Brandenburg in the time period 1998–2007 shows an ambivalent image (see Figure 3). Although many companies collaborate with research institutions, they almost always patent innovations by themselves.

Compared to the rest of Germany, the Capital Region generally registers fewer patents. This is also reflected in the field of optical technologies and laser technology. If the Capital Region is further differentiated regionally, the patent work of the laser companies is clearly concentrated in Berlin. The trend of the patent registrations shows (see again Figure 3) that relatively many patents were registered in the years 1999 and 2000. By 2006, a lot fewer patents were registered. This trend fortunately broke in 2007.

3.0

Simple ruby laser,
late 1961 at the Department of
Physics I at the TU Berlin
Source: TU Berlin

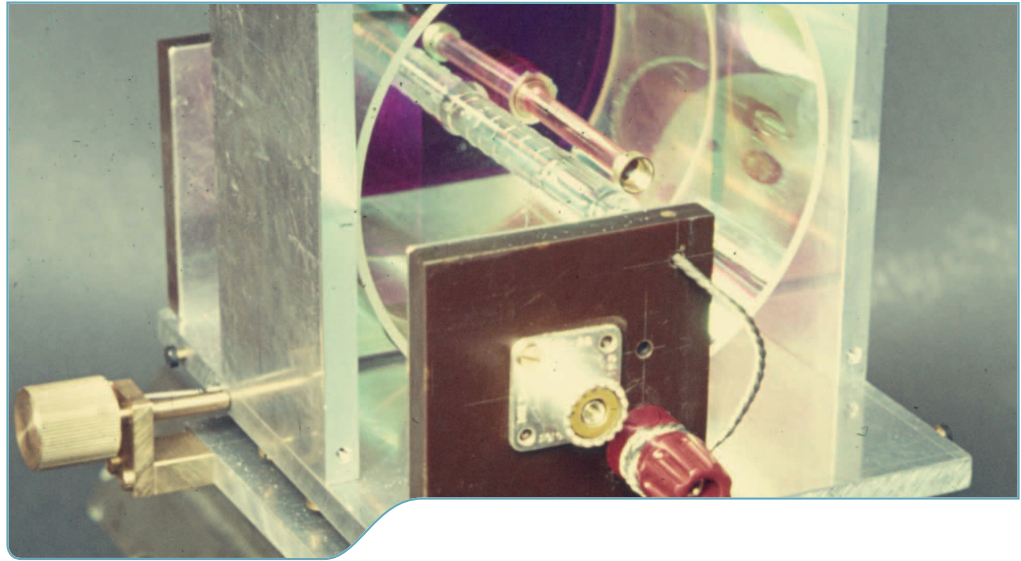

Dr. Frank Lerch

4.0

History

The History of Laser Development in Berlin

In 2010, the 50-year anniversary of the invention of the laser by the American Theodore H. Maiman in 1960 is celebrated all over the world. However, important theoretical and experimental foundations for the rapid development of laser technology were established much earlier in Berlin.

After Max Planck and Walter Nernst managed to appoint Albert Einstein as a full-time salaried member of the Prussian Academy of Sciences in Berlin in 1914, where he became director of the new Kaiser Wilhelm Institute for Physics in 1917, Einstein completed his general theory of relativity in 1915. One year later, he postulated the theory of absorption and stimulated emission of light quanta in his paper "Zur Quantentheorie der Strahlung" (On the Quantum Theory of Radiation). According to the essay, certain materials could be irradiated by light in such a manner that

they emitted light as a result of the exchange of energy. He described this process as a "change of state by irradiation" and thus shaped the theoretical foundation of modern laser technology.

Less well known is the fact that the experimental proof of stimulated emission also first succeeded in Berlin. The name Rudolph Ladenburg is linked to this success. He had obtained his doctorate under Röntgen in 1906 and his habilitation at the Department of Physics in Breslau in 1909. As of 1921, he directed the department of "sound ranging" he had founded at the Artillery Examination Board in Berlin, where also Max Born worked (Gönner, 2005). In 1924 Ladenburg took over the Department of Atomic Physics at the Kaiser Wilhelm Institute for Physical Chemistry and Electrochemistry (since 1948: Fritz Haber Institute of the Max Planck Society) in Berlin-Dahlem. This is where, in 1928, Ladenburg and Hans Kopfermann were the first to unambiguously observe negative dispersion (light amplification) for spectral lines of electrically stimulated neon and, therefore, give experimental evidence for the stimulated emission predicted by Einstein (Minkowski, 1929; Kopfermann, 1952). If Kopfermann had held the gas discharge between two highly reflective mirrors, it might be speculated that he probably would have already had a He-Ne laser in 1930.

The seizure of power by the Nazis, the resulting emigration of important physicists from Berlin and Ger-



Einstein's 70th birthday on
March 14, 1949, f. l.: Robertsen,
Wigner, Weyl, Einstein, Laden-
burg, Oppenheimer, Clemence

Source:

Archives of the Max Planck Society,
Berlin-Dahlem

many, and the damages caused by the war almost halted physics research in Berlin. From then on, further basic technological development of laser technology happened in the USA and the USSR. In 1955 Gordon, Zeiger and Townes of New York's Columbia University demonstrated microwave amplification (maser) during passage of a suitable medium. In 1958 Schawlow (Bell Labs) and Townes worked on the transfer of these new insights to the field of optics. However, in 1960 Maiman from Hughes Aircraft Laboratories was the first to demonstrate the laser principle experimentally. He built a flash-lamp-pumped ruby laser capable of delivering coherent red (694 nm) radiation.

In Berlin, divided by the Iron Curtain at that time, laser technology was not only developed in two separate countries, but also in two increasingly different scientific and economic systems. In West Berlin the first small group of young laser researchers in Germany was formed at the I. Department of Physics at the Technical University of Berlin. Professor Boersch, who had previously worked at AEG on the development of electron microscopy – in competition with Ernst Ruska's Siemens Group –, became director of the I. Department of Physics at the Technical University of Berlin in 1954. When the first laser was developed in 1960, Boersch immediately founded a research group at his institute. Around 1960, Boersch's two doctoral students, Horst Weber and Gerd Herziger, were searching for topics for their theses. At that time, the new developments in laser technology promised to be an up-and-coming field of research. Many researchers were conscious of the great application potential early on. In late 1961 and early 1962, the two doctoral students were able to complete their first own solid state and gas lasers. The only other group at that time was found at Siemens in Munich. The components for the first ruby laser at the TU Berlin were, among others, made from a flashbulb from Osram, mirrors manufactured by Halle in Berlin, and crystals from the company Djeva from Monthey, Switzerland. Rubies, used as watch stones, were actually not well suited for the construction of lasers. The mirror coatings were supplied by the II. Department of Physics at the Technical University of Berlin directed by Professor Gobrecht.

These first lasers were initially used for drilling platinum diaphragms for electro-optical beam paths of a few μm . Professor Boersch recognized that the future of laser technology was going to be in material processing.

In the early years of German laser research, the I. Department of Physics at the TU Berlin quickly became the West German center of experimental laser research (Albrecht, 1997). The first presentation was held at the physics congress 1963 in Hamburg. For the first time, a separate section concentrated on the subject of lasers. Three of four presentations were

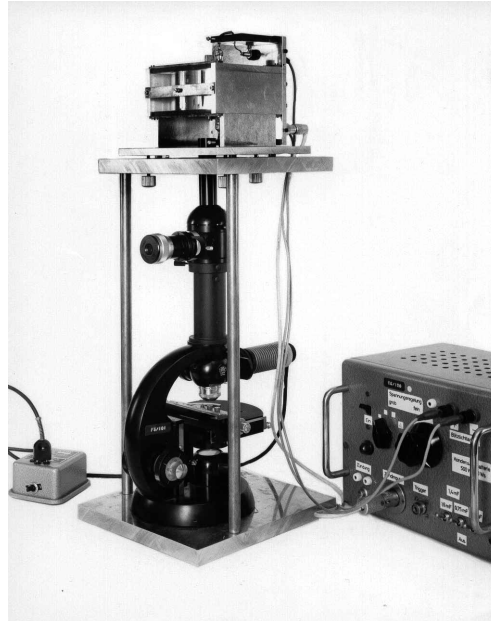

Setup for micromachining, ruby laser on a Zeiss microscope at the I. Department of Physics at the TU Berlin

Source: TU Berlin

held by members of the Boersch group. In the following years, members of the research group were represented at the majority of German physics meetings, usually with presentations on the fundamentals of solid state and gas lasers. Papers on technical laser applications and international performances were exceptions, the former due to Boersch's view of industrial contracts affecting the freedom of his research – surely an insight from his work for AEG (see Albrecht, 2001).

The TU Berlin has produced many successes in the field of laser research, such as the development of a highly stable laser, the creation of very short laser pulses and the development of high-power ion lasers (Niedrig, 1987). The result was an outstanding position in Germany. Internationally however, they did not receive similar recognition. In 1969, Weber and Herziger left the group to go to the University of Bern and work on industrial research. Afterwards Joachim Eichler led the research group. In the following years, the activities at the Institute of Optics at the TU Berlin primarily focused on measurement technology and medical applications of lasers, and later diode lasers.

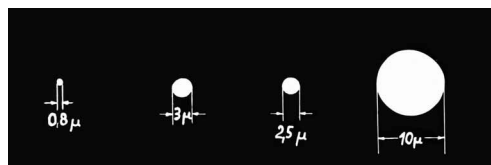

Production of diaphragms via micro-drilling with the ruby laser at the I. Department of Physics at the TU Berlin

Source: TU Berlin

Drilling of a steel plate with the ruby laser at the I. Department of Physics at the TU Berlin

Source: TU Berlin

Weber returned to the Technical University in Berlin in 1988, and Herziger took over the formation and direction of the Fraunhofer Institute for Laser Technology in Aachen in 1984.

4.0

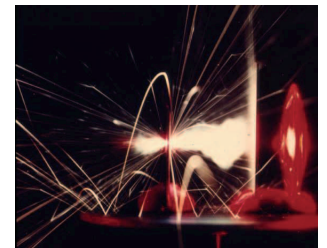

The first research and development work on lasers in the GDR also began shortly after the publication of the implementation of the laser effect by Maiman. The Physics Department of the University of Jena, in close connection with the research department of Carl Zeiss Jena and the Institute of Optics and Spectroscopy of the Academy of Sciences of the GDR in Berlin-Adlershof, played a key role. Paul Görlich – also honorary professor in Jena, research director of Zeiss and co-director of the Institute of Optics and Spectroscopy – became the promoter of early laser research and development in the GDR. He initiated a competition for the first “socialist laser” between the two institutes. Amazingly, Berlin narrowly won. Remarkably, the Berlin researcher Kurt Lenz produced his first ruby laser, which he developed as a tool for atmospheric research, almost single-handedly, whereas the university research group in Jena had significant support of the VEB Carl Zeiss Jena (see Albrecht, 2001).

uled and a commission was invited which included Görlich (see Lenz, 1995). Officially, the ruby laser effect was first demonstrated in the GDR in Berlin on August 8, 1962. A few days later, the colleagues from Jena followed with their own ruby laser and, in Oc-

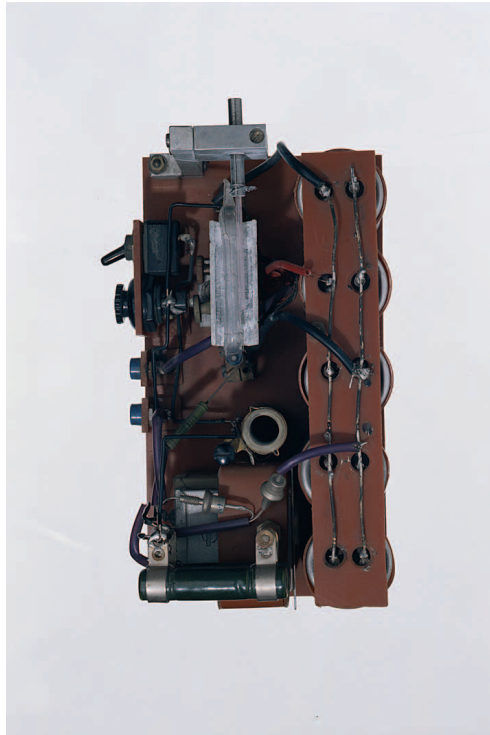
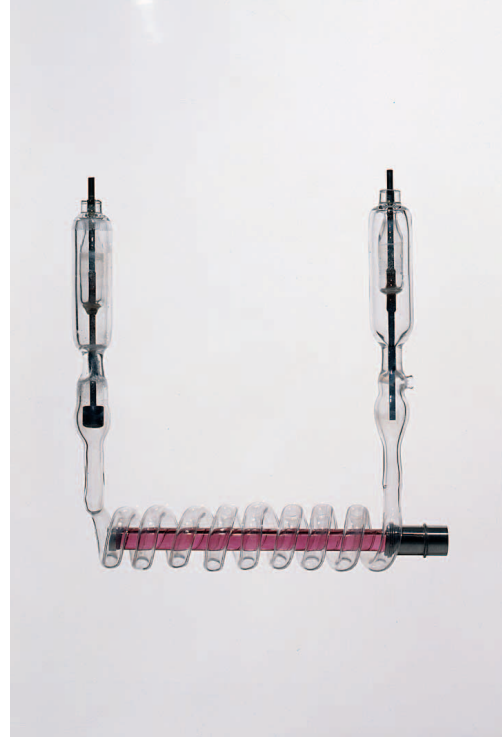

tober 1962, demonstrated the first gas laser. From then on, all known types of lasers (ruby laser, gas laser, calcium fluoride laser, glass laser and dye laser) were being worked on in Jena, supported by Zeiss and Görlich (Albrecht, 1997). Jena became the center of academic solid state and gas laser research in East Germany (Albrecht, 2001).

However, the Academy of Sciences and, in particular, the Central Institute of Optics and Spectroscopy (ZOS) in Berlin did have a significant impact on the laser development in the GDR. In the second half of the 60's, He-Ne lasers for basic research were built at the ZOS, e.g. for spectroscopic analysis. In 1969, a construction laser for surveying was developed and applied in various sectors of the GDR economy, for example in power plant construction, shipbuilding and civil engineering. At this time, the development of an argon and cw CO₂ laser also began at the ZOS. The results of the former were however transferred to Carl Zeiss Jena in 1973, where the production of the ILA 120 began in 1975. The cw CO₂ laser was developed earlier at the ZOS according to the module principle for material processing (applications in glass or textile processing). It was further developed at the Center for Scientific Instruments (ZWG) in 1971 and finally transferred to the VEB FEHA in Halle in 1975. In 1975, the first GDR cw dye laser was put into operation at the ZOS. It was further developed at the

Lenz had been alerted to lasers first by Bulgarian colleagues in 1961. Equipped with a copy of Maiman's publication, which he had received from a Bulgarian colleague, he began working under difficult conditions in relative international isolation and under the West's technology embargo against East Germany. Yet, rubies could still be mined in Bitterfeld, flashlights could be provided by the company Pressler in Leipzig, and he procured phase-shifting capacitors on his own. In the first successful experiment, the last flashbulb had exploded. Therefore, the success message to Professor Ritschl was combined with a request for new lamps. A new experiment was sched-

4.0

Small ruby laser by Lenz 1965 (left)

Flashbulbs with ruby rod for a laser by Kurt Lenz 1963 (right)

Source: Deutsches Museum Bonn

ZWG into the FSL 100, in cooperation with the University of Jena. In turn, the FSL 100 was then further developed into the FSL 101 with computer control at the ZWG.

Leipzig became the leading industry location in the development of semiconductor lasers in the GDR, but the ZOS Berlin and the Television Electronics Works ("Werk für Fernsehelektronik") in Berlin-Oberschö-

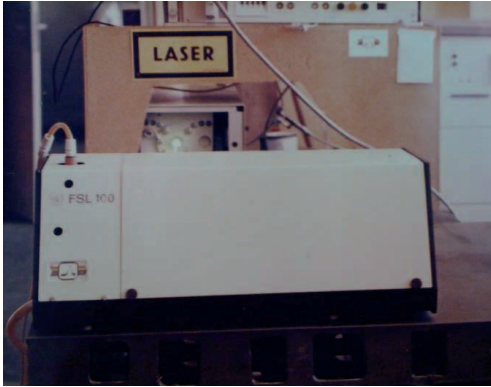

new therapeutic and diagnostic procedures which have been transferred into clinical practice: the re-opening of closed blood vessels (laser angioplasty), the laser-induced lithotripsy of kidney, gallbladder and salivary stones, the obliteration of tumors and metastases using interstitial laser thermotherapy, and optical scanning for the early detection and monitoring of various diseases such as rheumatism, all



Dye Laser FSL 100 at the Central Institute of Optics and Spectroscopy (left)

FSL 101 with computer control (right)

Source:
WISTA Management GmbH

neweide (WF) also contributed major developments. For example, using semiconductors, the laser effect was first proved in East Germany in Berlin in 1964. In terms of applications, scientists at the ZOS worked with partners from the WF on semiconductor devices for information transmission via fiberglass for the German postal service in the late 70's.

There were efforts to establish a Fraunhofer Institute for laser technology in Berlin (West) in the early 80's. They failed due to lack of matching funding. In 1985, the Laser-Medizin-Zentrum GmbH (LMZ) under the direction of Professor Müller, and in 1987, the Festkörper-Laser-Institut GmbH (FLI) under the guidance of Professor Weber, were founded as affiliated institutes of the FU and TU Berlin, respectively. The Laser-Medizin-Zentrum was the first laser medical research and development institute in the Federal Republic of Germany. The two institutions were merged to form the Laser-Medizin-Technik Berlin GmbH (LMTB) in 1995. Both independently and then jointly following the merger, close research and development collaborations with universities, hospitals and the industry of Berlin were established, resulting in significant contributions to laser medicine and laser technology. Particularly noteworthy are a number of

the way to methods of optical molecular imaging (Albrecht, 2005). Initially, the lasers developed in the technical sector were solid state high-power lasers in the kW range, and later high performance diode-pumped lasers, built in cooperation with West German companies.

After 1989, the field of optical technology and the precision engineering industry in Berlin and Brandenburg experienced a comprehensive transformation (see Lerch, 2009). With the change in political direction came the end of the facilities of the Academy of Sciences in Berlin (East). The survey by the science council (1992) recognized a wide range of laser research and development activities, in particular at the ZOS, ZWG, and the "Zentralinstitut für Elektronenphysik" (Central Institute of Electron Physics). However, only parts of the activities were transferred to new research institutions on the so-called "Blue List". Many "released" scientists started over as entrepreneurs and became part of a dynamics persisting to this day and reaching far beyond the field of laser development in the Berlin area. Special thanks go to Professor Dr. Horst Weber and Professor Dr. Klaus Junge. The author is grateful for comments, additions and suggestions.

4.0



Prof. Dr. Thomas Elsässer (l.)
Dr.-Ing. Helmut Ringelhan (r.)

Interview by Markus Wabersky

5.0

Prof. Dr. Thomas Elsässer and Dr.-Ing. Helmut Ringelhan Expert Interview Laser Technology

Since 1993, **Prof. Dr. Thomas Elsässer** has been a director at the Max Born Institute for Nonlinear Optics and Short Pulse Spectroscopy. Since 1994 he is also a full (C4-S) professor of experimental physics at the Humboldt University in Berlin. Thomas Elsässer studied physics in Heidelberg and at the Technical University of Munich, where he received his diploma in physics in 1982. At the TU Munich, he finished his PhD work on ultra-fast spectroscopy in 1986 (Dr. rer. nat.). He received his habilitation in 1991. Thomas Elsässer has published more than 350 papers in peer reviewed journals and books, holds 6 patents, and has presented more than 240 invited talks and lectures.

Max Born Institute for Nonlinear Optics and Short Pulse Spectroscopy in the Forschungsverbund Berlin e.V.

Member of the Leibniz Association. The Max Born Institute (MBI) conducts basic research in the field of nonlinear optics and ultrafast dynamics of the interaction of laser light with matter. It pursues applications that emerge from this research. It develops and uses ultrafast and ultra-intense lasers and laser-based short pulse light sources in a broad spectral range in combination with methods of nonlinear spectroscopy.

Telephone: +49 - 30 - 6392 1402
wettstein@mbi-berlin.de
www.mbi-berlin.de

Since 2000, **Dr.-Ing. Helmut Ringelhan** has been the managing director of the Photon Laser Engineering GmbH, a company in the Photon Group. Following his studies of mechanical engineering at TU Berlin, he was active in various institutions and companies in optics and laser technology beginning in 1974. Since 2002, Dr. Ringelhan is also Chairman of the Laserverbund Berlin-Brandenburg e.V.

The **Laserverbund Berlin Brandenburg e.V.** was founded in 1993 and has 100 members today. Objectives are to promote connections between science and the industry and among industry partners in terms of laser research, development and applications in Berlin and Brandenburg.

Telephone: +49 - 30 - 364088-22
H.Ringelhan@PhotonAG.com
Ringelhan@Laserverbund.de
www.Laserverbund.de

The **Photon Laser Engineering GmbH** is specialized in material processing with high-power lasers for the automotive industry, aerospace, engineering and railway vehicle manufacturing. The focus lies on process development, sensors, mass production and training.

Telephone: +49 - 30 - 364088-0
LE@PhotonAG.com
www.LE.PhotonAG.com

1. The laser turns 50 years old this year. Which development steps were crucial to the very successful development of laser technology? From your point of view, which are the milestones?

Prof. Elsässer: The principle of lasers is even older. The story begins in 1917 with Einstein's "On the Quantum Theory of Radiation". It physically described stimulated emission – the basis for all lasers. 50 years ago, the laser was experimentally demonstrated for the first time. Two groups performed the experiment almost simultaneously, both with ruby lasers. Throughout history, a wide variety of lasers, based on different principles, has been created. At the beginning, the lasers used were flashbulb-pumped. Today, many lasers are pumped by semiconductor lasers, which have a much higher efficiency. Crucial development steps were first of all the development and usage of new, active materials, which still is and will remain a current research topic. The second important development direction was the invention and testing of pump mechanisms other than optical ones, in particular electric pumping in the semiconductor laser. The latter is by far the most efficient method. Other important steps were the refinement of the geometry of the laser, of the resonators and the optical components, and methods changing the time structure of laser emission all the way into the ultra-short range. The most important aspect of the development was and is the multitude of different directions of development for various applications. The fact that the laser is an extremely flexible light source which can be tailored to the application is the foundation of today's laser technology. Alongside laser technology, nonlinear optics also plays an important role for the variation of the wavelengths and time structure of the generated light.

2. Which areas are emphasized in Berlin?

Prof. Elsässer: The first East German ruby laser was developed at the Central Institute of Optics and Spectroscopy in Berlin in cooperation with Russian scientists. Berlin also has a great tradition of solid state laser research and applications, supported mainly by the different groups of the TU Berlin. The current laser scene in Berlin has a strong international focus and is well positioned with non-university research institutions such as the Max Born Institute and the Ferdinand Braun Institute.

Dr. Ringelhan: I see the cooperation between science and industry as a major focus in Berlin, and, not to forget, in the surrounding area Brandenburg, too. There are not enough manufacturers using the laser as a measurement instrument and processing tool in Berlin. What's really great in Berlin are the

short distances between players. I see railway vehicles and aerospace as new important industry emphases in material processing with lasers. These sectors are strongly represented in the region, and the Photon Group is among the leaders. Medical applications are also well represented in the region and still offer great potential.

Dr. Ringelhan:

"What's really great in Berlin are the short distances between players."

3. It is not possible to imagine the modern world without the laser. A bright future is predicted for it. Which themes and long-term trends do you see today?

Prof. Elsässer: Information storage and transfer continues to be a very important development. Communication technology in the land-line telephone network is already primarily optical, and the demand for rapidly increasing data transmission capabilities, such as for the internet, can only be satisfied optically. There are already systems in laboratories enabling transmission rates of more than 10^{12} bits per second (terabit per second).

Therefore, communication technology reaches the ultra-short range. Ultra-short light pulses in combination with adequate modulation techniques are particularly important here. In general, many problems that have been solved with electric technologies in the past will be solved optically in the future. In the consumer sector, this concerns display and projection technologies, perhaps television, and the improvement of data storage and playback, such as the Blu-ray DVD. Higher quality, higher speed and higher data volume are main topics of development. Another important issue is material processing, e.g. drilling, cutting and welding of metals. A good example is machine tool manufacturing; German companies are world leaders in this field. Medical applications also still have enormous potential, for example in ophthalmology or cancer diagnosis and therapy. Some systems in measurement and analysis technology, which have not been optical so far, will be changed to optical methods in the future, increasing reliability and sensitivity.

4. Which key problems and research tasks have to be solved for these developments in the future? What can the research environment in Berlin contribute, the Max Born Institute in particular?

Prof. Elsässer: Generating light with parameters as variable as possible remains a key problem. A source

5.0

“A dream of the researchers would be an optical synthesizer.”

Prof. Elsässer:

of light with wavelengths from far infrared to the x-ray range, a free choice of time structure and intensity, i.e. an optical synthesizer, would be a dream come true. A related goal is to shorten the time structure. Today, we are already in the atto-second domain, so we are able to see the movement of electrons in materials time-resolved. This is linked to the development of ever shorter wavelengths. At the Max Born Institute, we are specialized in short and ultra-short light pulses for observing fast processes of certain applications.

Another development important to us is the generation of extremely high intensities in order to shift matter into new states or to accelerate particles.

Prof. Elsässer: In the medical field the potential is certainly visible, but not all opportunities have been exploited or implemented in devices. This also results from the complex licensing process and the development effort necessary for making the laser easy to apply and safe for technical amateurs. The laser in a CD player is not a problem because the system is closed. Other security requirements apply when dealing with open lasers. This concerns the medical field as well as measurement technology.

An important aspect is the high costs compared to conventional technologies. For example, in material processing many things can be done better with short pulse lasers than with other methods, but the high costs have prevented this method to spread. If sales volume were higher, the devices would be cheaper and therefore lead to further acceptance. You need people willing to transfer the technology into applications at a high-risk and, in the end, earning money with it.

Dr. Ringelhan: I see many areas which still have the potential to use the laser more and better. In material processing, the laser is widely used for cutting in the plane and for inscriptions. I believe assembly is a new interesting market, especially in connection with systems that can also be used by handy people. Generally, there is great potential in a broader application of lasers.

To further exploit the potential, more industry players, developers and users should be brought together. User workshops and seminars are a good medium, designed not only for specialists but also for new target groups such as handy people. Successful examples are the gold and silver smiths, which have come to appreciate the laser as an everyday tool.

7. It is often criticized, that the technology and knowledge transfer from science to industry does not do justice to its potential. In your opinion, why is this the case and how could changes be made, especially in the field of lasers and in Berlin?

Prof. Elsässer: The cooperation network in Berlin works quite well, especially here in Adlershof. Berlin is at the top internationally in some areas, for example in research with x-radiation and x-ray technologies. There is also great potential in the field of measurement technology and in microsystems technology.

The transfer of research into the industry is not as bad in Germany as often said. For further improvement, it is important to bring together providers and recipients of research more. People should know and talk to each other to develop cooperations. Companies need to know what is going on here and the institutes must understand the needs of the companies.

5. On which issues and technologies should businesses and start-ups focus on for a long-term market success?

Dr. Ringelhan:

“Customers of laser companies want solutions to problems.”

Dr. Ringelhan: As in other industries, customers of laser companies want solutions to problems. Whether these solutions are implemented with lasers or other technologies is secondary to the customers. Small and medium-sized businesses are often well qualified for customer-oriented solutions. These solutions are often quite pragmatic. Cheaper, faster production with less reworking is of interest across all sectors of industry.

An important development, especially in terms of material processing, is the laser “growing” into the system; the system point of view is central.

Unfortunately, engineers often don’t actually integrate the laser into systems or generally don’t increasingly accept the laser as a tool, and they don’t think and construct with the laser in mind. Many do not even know what can be done with the light beam.

6. The laser is an interdisciplinary technology with great potential for many industries and applications. In which areas is the laser not applied commensurate to its current stage of technology, even though it would be possible? What are the reasons and how could this be changed?

5.0

What hinders developments is a widespread skepticism in the general public about high technology. That is less the case in, for example, the United States. The entrepreneurial mentality in the U.S. is also different. A founder or manager who has failed gets a new chance. In Germany and in other European countries, failure can be compared to the destruction of existences, so many people shy away from risks.

In terms of technology transfer, no individual company should be subsidized via publicly financed developments. Meanwhile, the EU sees this with very critical eyes.

Legal issues and the organization of cooperations are important topics for the improvement of the transfer. There is not enough support offered for the solution of these questions in Germany.

Dr. Ringelhan: The laser as a tool must be further integrated into the different directions of education. Future engineers or technicians know too little about the possibilities of the laser. The potential and the possible technological changes are not recognized early enough.

Practical problems are the high investment costs of lasers and the fact that there are not enough people who know how to handle lasers. The education and training opportunities in Germany are not sufficient yet. This also leads to the shortage of skilled workers, hindering further acceptance of the laser.

8. The current financial and economic crisis has led to hard times for some German industries, such as mechanical engineering and the automotive industry. Which effects are found in the laser industry? Which sectors were barely affected, and which severely?

Dr. Ringelhan:

“The most difficult phase of the crisis is surely over.”

Dr. Ringelhan: The impact of the financial and economic crisis shows once again that laser technology is an interdisciplinary technology. Companies were either strongly or hardly affected, depending on the user industry. Our company operates very strongly in the automotive industry and is now focusing more and more on other sectors, such as railroad vehicles and aerospace. But we are optimistic again. The most difficult phase is surely over.

9. What are the effects of the crisis on research institutions, in Germany and in Berlin especially? Are there restrictions on collaborations with industry and

on third-party funding? Do you expect cutbacks in research funds due to the government's difficult budgetary position?

Prof. Elsässer: So far, we have no cutbacks, but rather budget increases of up to 5% per year. We have also benefited from the economic stimulus plans, particularly in the infrastructure field, for example for investments in buildings or in research equipment. Whether or not this will be changing if the budget situation continues to deteriorate cannot be predicted yet.

The companies have very different situations, depending on how well their business is going. Overall, we have hardly felt the impact of the crisis so far.

10. Many industries see China as a large and unpredictable competitor in the world market. Can the research in China already be counted among the world's best? How do you see the further development of Chinese science?

Prof. Elsässer: China is certainly the most important emerging market, also in research. It is interesting that young researchers in the U.S. are often Chinese,

Prof. Elsässer:

“The Chinese have recognized: research is a key to success.”

who obtain their doctorate in the U.S. and can develop themselves. In the meantime, the Chinese government has launched several large programs to bring back some of these people. Research is a dominant subject in the Chinese agenda. The Chinese have recognized research as a key to future success. There are several universities and research laboratories in China which do not differ from Western industrial nations in terms of quality of teaching and research and equipment.

And, of course, there are brilliant research scientists also in China. I believe there will be a stronger competition in the future, but no domination by China. There will always be strengths and weaknesses in the relevant countries.

Prof. Elsässer:

“Optical technologies are powerful areas of growth.”

11. How does Germany compare to other countries, such as the U.S. or Japan?

5.0

Prof. Elsässer: All three countries do top level research in optical technologies and develop high technology products based on lasers. The financial resources for research are somewhat better in Germany and Japan compared to the U.S. The American research system is very competitive. Almost everything runs on project financing. In Germany, basic institutional funding of universities and research institutions enables longer-term research in particular. You have to also consider the fact, that there is not only top level research in the U.S., but rather a broad range in quality. In Germany, we need to make sure

search is not large machine physics, you can still really do something new as an individual or a small team in a well equipped laboratory. It is complex, but manageable. This is especially interesting for students and young researchers.

Dr. Ringelhan: As an apprentice, I was fascinated by a foreman working on a test, polishing a red rod, highly concentrated. It was a laser crystal and, for me, the insight that you can do much more with light than use it as a signal carrier and tool.

Prof. Elsässer:

“In laser research, you can still conduct an exciting experiment as an individual.”

5.0

we keep our position in the top segment and attract the best international minds. A central problem is the lacking competitiveness of wages for researchers, compared to international standards. This fact has to be changed by German politics urgently.

12. You both have a long and successful career in the field of lasers. How did you become involved with lasers, what fascinated and induced you to devote your professional life to the laser? Were there any key moments supporting you in your decision?

Prof. Elsässer: I was a physics student at the TU Munich when I became involved with lasers. I was fascinated by the methods for producing light and the numerous applications. Also, experimental laser re-

13. How do you advise young people today, who are interested in a career as a scientist or engineer in the field of lasers? Why is laser technology a good choice?

Prof. Elsässer: Laser technology and physics in general are a good choice because there are interdisciplinary fields. Someone who has a broad overview of laser technology can work in very different areas. Optical technologies are also strong growth segments, which will play an even greater role in the future. It is important that the education is good and not too specialized. A broad education prevents the youth from being stuck in a dead end after 10 years because knowledge and techniques have changed.

Dr. Ringelhan: Because electromagnetic waves, optics, the era of the photon offer so many possible applications. This does not only have to be information and data transmission; diagnosis and treatment of diseases or material processing can also be very fulfilling and exciting areas. Everybody can find room for growth in the area of light.

The interviews were conducted in February 2010.

Laser Technology in Science and Industry

6.0

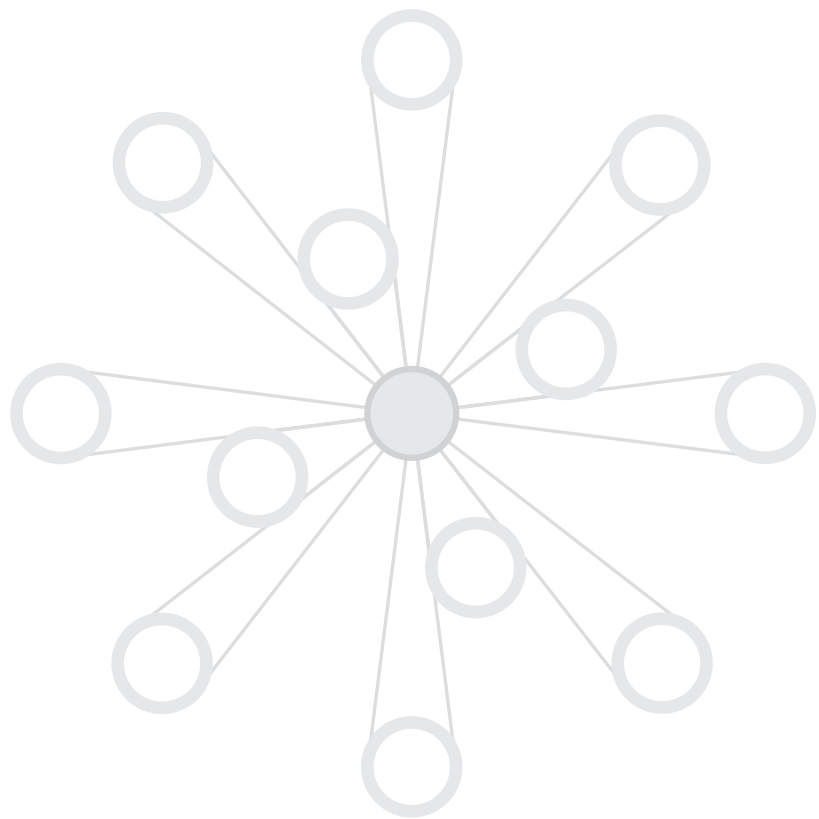

High frequency control circuit for short pulses generation

Source: Ferdinand Braun Institute,
Leibniz Institute for
Highest Frequency Technology
© FBH/schurian.com

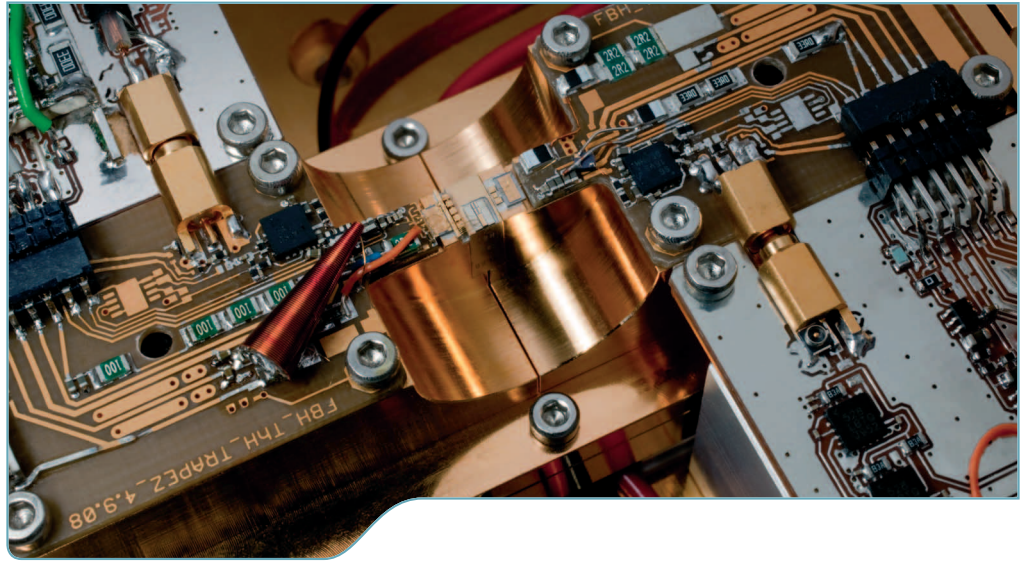

Kai Kolwitz

6.1

Foundations and Applications in Research Laser Technology in Science in Berlin-Brandenburg

One of the main advantages of the laser is its ability to adapt to the necessities of different application fields. This makes it interesting for many research facilities, in basic research and in application-oriented areas. The potential of the technology has not been exhausted yet. No matter if in material processing, communication or medicine – new application fields are constantly opened up in which the laser can exploit its strengths and in others existing limits are pushed.

A closely networked research environment ensures continuous development in Berlin and Brandenburg. The Max Born Institute for Nonlinear Optics and Short Pulse Spectroscopy works on both basic and applied research. It studies the interaction of matter with ultra-short pulsed laser light. To this end, the institute develops ultra-intense lasers and laser-driven short pulse light sources in a broad spectral range – lasers operating in the femto-second range and concentrating their power in the terawatt range during this short time period. This enables the analysis and control of ultra-fast processes in atoms, molecules and solids, all the way to the motion of single electrons. Possible applications range from analytics to material processing: femto-second pulses are so short that heating of the material hardly matters. Chemical reactions can also be studied with fast laser pulses. Among others, the Department of Physics at the Freie Universität Berlin is working on these studies.

The Fritz Haber Institute in Berlin also uses lasers for its studies. The institute focuses on molecular physics and the study of catalytic processes at the molecular level. Its Department of Chemical Physics examines, for example, the adhesion and detachment processes of molecules on the surfaces of solids. The laser is used to stimulate detachment processes and detect them via two-photon photoemission spectroscopy. In addition, the adhesion of molecules on solid surfaces is studied as a function of ambient pressure. The so-called sum frequency generation is used for these examinations whereby laser light with a certain optical frequency is beamed onto the area to be examined together with a variable frequency infrared laser. The variation of the polarization of the beamed laser light in the infrared range is used for analysis.

The Max Planck Institute of Colloids and Interfaces in Golm in Brandenburg uses laser spectroscopy techniques for monitoring biomedical experiments in very small structures. The Paul Drude Institute for Solid State Electronics in Berlin is also working on basic research for the development of new laser types. It examines semiconductor structures and the principles of quantum cascade lasers. Those are lasers in which light is created via inter-sub-band transitions of electrons within the conduction band. The frequencies range from the mid-infrared to the terahertz range.

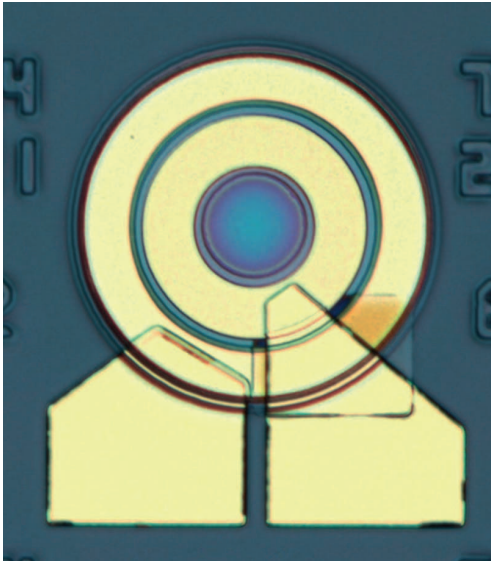

Diversified – Ferdinand Braun Institute, TU Berlin and University of Potsdam

The Ferdinand Braun Institute, Leibniz Institute for Highest Frequency Technology (FBH), is also involved in NanOp. When it comes to the development of laser technology and its transfer into applications in Berlin, the FBH is more often than not at the center of activities. The institute studies semiconductor-based electronic components and develops powerful and highly brilliant diode laser and hybrid systems. The goal is to continue to “push the envelope”, for example in developing of compact diode lasers emitting green and blue light with sufficient power. The institute has its own manufacturing capabilities and a strong application orientation. Consequently, several companies have been spun off from the FBH in the recent years, including eagleyard Photonics and Jenoptik Diode Lab. The institute’s laser know-how is found in applications from medical technology and analytics via communication all the way to material processing.

Microscopic image of a surface-emitting laser (VCSEL)

Source: TU Berlin – Institute for Solid State Physics

The Paul Drude Institute focuses its research on lasers based on gallium arsenide. The Institute for Solid State Physics at the Technical University of Berlin is also interested in fundamentals: optical, electrical and magnetic properties of semiconductors, amorphous layers and hetero structures are studied at world class level. The knowledge is used for research, development and characterization of novel optoelectronic and electronic components which can be built in their clean rooms. The spectrum of components includes directly modulated lasers, mode-locked lasers, semiconductor amplifiers, surface-emitting lasers (VCSEL) and edge-emitters with high power and brilliance. Another emphasis is on quantum dot structures in semiconductors, i.e. structures in which charge particles can only assume discrete energy values. The Institute for Solid State Physics is

One of the latest developments at the FBH is a pulse picker, a powerful hybrid laser system. It is based on a novel concept for the selection of single pulses from high-frequency pulse series of mode-locked lasers – single pulses are precisely selected. The pulse picker operates on a pure semiconductor technology basis. It can provide ultra-short light pulses of less than 10 picoseconds with almost any repetition frequencies, from kilohertz to the 100-mega-

6.1

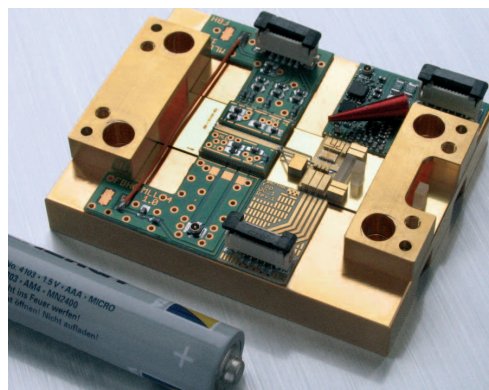

Pulse picker for the precise selection of single laser pulses

Source: Ferdinand Braun Institut, Leibniz Institute for Highest Frequency Technology
© FBH/P. Immerz

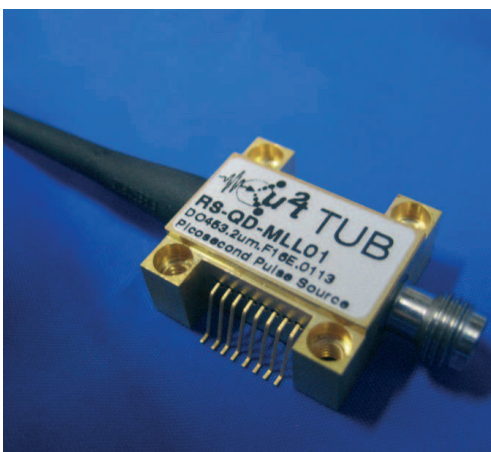

hertz range. In cooperation with the Quantum Optics and Metrology group at the Humboldt University in Berlin, the FBH is also engaged in the development of laser-based measurement technology for the highly accurate determination of long distances. The Institute of Optics and Atomic Physics of the TU Berlin (IOAP) is also active in many areas. Several working groups deal with such diverse issues as spectroscopy and environment-physical analysis methods, femto-second lasers, light-matter interactions in intense laser fields (together with the Max Born Institute) or the development of new optical storage media. In terms of material processing, the institute studies methods for the production of solar

Mode-locked laser module

Source: TU Berlin – Institute for Solid State Physics

also involved in the NanOp cooperation, together with the Department of Physics at the Humboldt University of Berlin, the Fraunhofer Heinrich Hertz Institute, and other regional and international research partners. This cooperation aims to combine nanostructures and optoelectronics.

Percussion drilling in metals and ceramics up to 10 mm depth

Source: Oliver Lux, TU Berlin – Institute for Optics and Atomic Physics

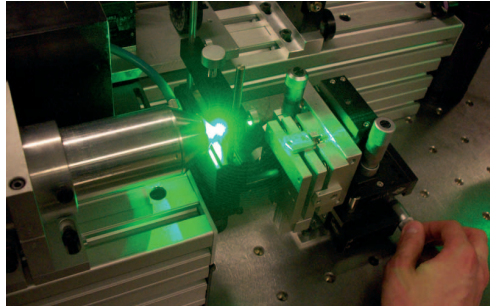

Percussion drilling

Source: Oliver Lux, TU Berlin – Institute for Optics and Atomic Physics

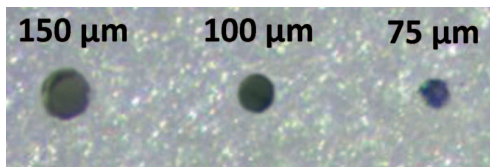

cells, for processing glass and percussion drilling, i.e. drilling of materials via pulsed laser radiation. Furthermore, the IOAP was involved in the development of a laser scanner which determines the freshness of meat spectroscopically.

The University of Potsdam also does research on and with lasers. The Photonics group focuses on time-resolved laser spectrometry on time scales ranging from femto- to millisecond. The emphasis lies on research into nonlinear properties of molecular systems. A second emphasis of Potsdam's photonics is on the optimization and development of lasers: work is being done on high power solid state lasers, as well as on creation of phase-conjugating mirrors for compensating phase distortions in solid state lasers. In addition, work is also being done on the development of broadband short pulse lasers for interferometry and the improvement of beam quality of high power laser diodes.

Special Skills Required – Applied Research

There are not only institutions working on fundamental issues in Berlin and Brandenburg; many institutions focus on specific laser applications, such as communication. Today's data networks are light and fiberglass based, and lasers and detectors play an important role in further development. In Berlin the Fraunhofer Heinrich Hertz Institute, for example, does research with opto-chips, signal amplifiers and fast detectors. The Leibniz Institute for Innovative Microelectronics in Frankfurt (Oder) is also working in this area. It is active in the field of high-speed circuits and components, but has also developed laser-based sensors for medical diagnostics.

The various methods of spectroscopy are becoming increasingly important for medical diagnostics and the analysis of diverse materials. The University of Potsdam and the Astrophysical Institute Potsdam have therefore founded innoFSPEC. The abbreviation stands for "Innovative Fiber-Spectroscopy and Sensing". The joint facility is working on the physical

and technological basis for future systems of spectroscopy and sensing. It examines new optical fibers and waveguide structures. Other research objectives include the control of light propagation and the interactions of light-conducting structures and structural systems for spectroscopy and sensing with the environment.

The working group Bonding and Coating Technology at the TU Berlin researches material processing with lasers. For example, it is working on new bonding methods and bonds which can easily be broken for repair and recycling purposes. The Center for Laser Material Processing at the University of Applied Sciences in Brandenburg / Havel does research on methods for bonding materials with vastly different thicknesses, and on how to compensate for disadvantages in the processing of lead-free solder compared to the environmentally unfriendly predecessor. The Fraunhofer Institute for Production Systems and Design Technology (IPK) in Berlin is also specialized in bonding and coating technology. One of its research areas is laser and laser hybrid welding with an eye toward the entire life cycle, from production to recycling. Bonding processes are developed, studied and prepared for application.

The Department of Mechanical Engineering at the TU Berlin and the "Hochschule für Technik und Wirtschaft" (HTW) also study techniques for material processing via lasers. The main teaching and research focus at the Technical University of Applied Sciences in Wildau in Brandenburg, Optical Technologies, is active in many areas: Optical fibers and photo-induced changes in polymers are examined as well as electro-optical modulators or the cutting of metal foils via laser.

"Laser- und Medizin-Technologie Berlin" (LMTB) and the Institute for Medical Physics and Laser Medicine at the Freie Universität Berlin are engaged in medical laser applications. The Department of Physics even uses the laser to control the weather: long plasma strings generated by laser radiation may act as lightning rods or can determine the chance of rain. They are also applied in material analysis.

The Berlin Department of the Leibniz Institute for Analytical Sciences (ISAS) has specialized in the field of interface spectroscopy. The Institute works internationally, but also regards itself as a regional center in collaborations with companies, institutions, associations and universities. This is exemplified by "Elias", developed at ISAS. With this device, scientists developed an Echelle spectroscope capable of differentiating wavelengths of only 100 femto-meters. "Elias" is produced in several versions and distributed by LTB Lasertechnik Berlin. Overall, the main focus at the ISAS is the development of new, and optimization of existing, spectroscopic methods. Important goals for the future are the adequate use of

synchrotron radiation and the implementation of near-field optical vibrational spectroscopy for spatial resolutions in the nanometer scale.

Laser-based methods, not least spectroscopy, are also applied in astronomy. The FBH, for example, is working on communication systems for satellites. The Institute of Optics and Atomic Physics of the TU Berlin and the German Aerospace Center (DLR) are working together in the development of spectroscopic methods in the terahertz range. The technique will hopefully lead to new insights into the formation of stars and planets; it is integrated in observatories and space probes. The German Research Center for Geosciences in Potsdam (GFZ) measures our planet's gravity field by measuring the time it takes laser light to travel between satellites and the earth's surface. A laser telescope, operated by the GFZ in Potsdam, serves as a ground control station.

"Suppliers" on a High Level – Laser Research Needs Supporters

Whether basic or applied research, scientific work on and with lasers also needs research in related fields, one may call them "scientific suppliers". The Capital Region does – indeed – offer many such research facilities, which contribute to the development of lasers and applications.

The Leibniz Institute for Crystal Growth (IKZ) in Berlin is specialized in growing crystals and in the development of production processes for crystals used as components in solid state lasers. The Fraunhofer Institute for Applied Polymer Research (IAP) and the Fraunhofer Research Institution for Polymeric Materials and Composites (PYCO) study polymers which are a basis for stimulated light emission. The Institute of Thin Film and Microsensoric Technology in Teltow is also studying polymers which can be used in lasers and sensors. The Institute for Applied Photonics e.V. (IAP) is a non-profit industrial research organization active in basic and applied research, especially in x-ray physics and technology. Photonic crystal fibers for laser applications are a core competency of the IAP.

The Max Born Institute's partner for mathematical questions is the Weierstrass Institute for Applied Analysis and Stochastics (WIAS) in Berlin. And the Society for the Promotion of Applied Computer Science (GFaI) is also involved in laser research. It is located in the science and technology park Adlershof and supplies, for example, data and image processing software for the laser-scientific institutions.

Research on and with lasers can be multifaceted. In Berlin and Brandenburg, these facets can be observed.

6.1

Q-switched DiNY cwQ 200 MM fc with fiber coupling
Source: IBL Innovative Laser GmbH Berlin



Kai Kolwitz

6.2

Manufacturers and Suppliers Market Leaders and Specialists: Laser Technology is Booming in Berlin-Brandenburg

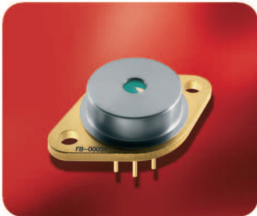

DBR laser

Source: eagleyard Photonics GmbH

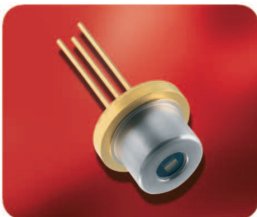

Ridge waveguide laser

Source: eagleyard Photonics GmbH



Broad area laser

Source: eagleyard Photonics GmbH

"We still see a very large growth potential." Jörg Muchametow is optimistic about the future. He is co-founder and managing director of eagleyard Photonics in Berlin. eagleyard is active in the business field of high-power laser diodes in the wavelength range 650–1120 nm. These lasers are applied in medical diagnosis and therapy, pump cesium and rubidium lasers in atomic clocks and are utilized in absorption and Raman spectroscopy.

From Research to Mass Application: Laser Diodes Made in Berlin-Brandenburg

The story of eagleyard is typical for many companies active in the field of lasers in Berlin and Brandenburg. Founded in 2002, eagleyard's products build on research done at the Ferdinand Braun Institute, Leibniz Institute for Highest Frequency Technology. "From a scientific point of view, certain phenomena had been thoroughly explored," says Muchametow. "But other criteria are also important for industrial applications. Products must work reliably. They have to be brought to series maturity and must be optimized for the production of large quantities." eagleyard has taken over this task and is extremely successful. Another important product developed through this collaboration is laser diodes emitting light in the green wavelength range. They are needed for projectors integrated into mobile phones or upcoming generations of mobile displays.

The close networking between science and industry is one of the great advantages of the Berlin-Brandenburg region. Quite a few of the companies producing laser technology in the region were spun off from universities. Another example is the company PBC Lasers. The abbreviation stands for Photonic Band Crystal Lasers. PBC was founded in 2008 as a spin-off from the Institute for Solid State Physics at the Technical University.

Today, laser diodes are developed with the university know-how. These diodes combine high performance and energy efficiency with high brilliance. PBC targets the mass market for material processing. Its technology enables PBC to filter unwanted modes and achieve beam qualities as high as those of solid state lasers with diodes.

The developers of PicoQuant are also experts in their field. PicoQuant works on diode lasers providing ultra-short pulses. The pulse frequencies are typically in the picosecond range, with repetition rates of up to 80 MHz. PicoQuant is also leading in the field of time-resolved fluorescence spectroscopy.

The wavelengths which can be generated cover the spectrum from the infrared to the ultraviolet. Ultra-short pulse frequencies enable applications such as counting individual photons. PicoQuant technology is applied in research, for example in biochemistry and genetics, as well as for cancer detection or tasks in quality control in large industrial companies.

Characteristic for PicoQuant, as for many other laser technology manufacturers in Berlin-Brandenburg is: PicoQuant is highly innovative. The company is continually working on increasing repetition rates and

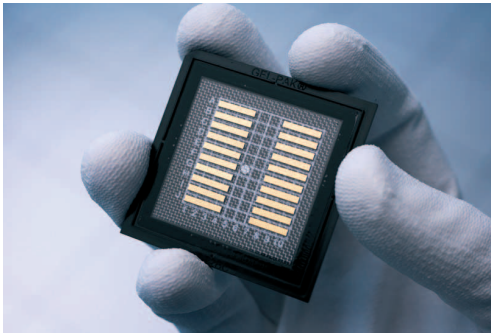

performance and expanding wavelength ranges. As highly innovative and as highly qualitative as possible on the one hand, but inexpensive and robust for mass applications on the other. The compact form factor and easy handling of laser diodes generates new laser applications all the time. There are probably only very few regions in Europe where so many developers, manufacturers and distributors are located in such a small area as in the Berlin region.

Lumics for example, located in the science and technology park in Adlershof, is one of only about 20 companies worldwide to master all process steps in manufacturing laser diode modules, from epitaxy to assembly. Lumics was also spun off from a research organization, the Max Planck Institute for Solid State Research in Stuttgart. They provide about 7000-8000 laser diode modules per year. The repertoire includes a wavelength range from 790 to 1500 nm wavelengths, as a fundamental mode or multimode laser emitter.

Lumics also focuses on the further technological development. Lumics protects the front and back of the crystals via facet passivation against corrosion. The durability of the diodes is greatly increased thereby. Typical products are fiber-coupled modules with 600 mW power delivered by a fundamental mode fiber. Complete beam sources deliver up to 600 watts from a 400-micron fiber.

Jenoptik Diode Labs is another well-known manufacturer of laser diodes located at the site. Diode Labs was also spun off from the Ferdinand Braun Institute. In association with Jenoptik Laser Diode GmbH, it is one of the few full-range suppliers of high-power diode lasers worldwide. From the wafer to unmounted semiconductor materials and mounted diode laser bars to high-quality refined products such as fiber-coupled diode lasers and stacks, Jenoptik offers the full range of diode lasers from a single supplier. Diode bars from Diode Labs are, for example, used for pumping solid state lasers. Other

applications are medicine, printing, security and defense technologies.

The range of products available locally is further expanded by Silicon Sensor. In early 2010, the company,



specialized in photodiodes anyway, announced a development and distribution agreement with the Korean manufacturer QSI. Therefore, Silicon Sensor is now a single supplier for both laser and photo diodes, the latter needed for modular construction. The "Optoelektronische Komponenten and Applikationen" GmbH (OECA), located in Hoppegarten in the outskirts of Berlin, builds complete customized laser modules with laser diodes. It processes almost all commercially available diodes with wavelengths between 400 nanometers and the mid-infrared range. Thermally stabilized systems are also available.

Not Only for Cutting and Drilling: Solid State Lasers

The company PhotonTec has specialized in these complete modules and the corresponding optics and fibers for the transmission of laser light. The output power ranges up to several hundred watts, the frequency spectrum ranges from blue to the near-infrared range.

PhotonTec holds a world record in a different area – the solid state laser. At 457 nm wavelength (blue area), PhotonTec lasers reach 10 watts output power, more than any other commercially available product. PhotonTec's solid state lasers are available in a wide wavelength range from the ultraviolet to the infrared. Crystals, optics and opto-mechanical components are also provided. The company's goal is to offer complete and customized solutions for a wide range of applications, from medical technology to material processing.

However, PhotonTec is not the only all-rounder in Berlin and Brandenburg. Newport Spectra-Physics, located in Stahnsdorf, just outside the Berlin city limits, also provides a wide product range. The company has an international reputation. It originated from the LAS GmbH, which was founded after the end of German division. LAS was soon known worldwide for innovative products, such as the world's

Manufacturing of laser bars (l.)
Source: Jenoptik Diode Lab GmbH

Production of epitaxial layers (r.)
Source: Jenoptik Diode Lab GmbH

6.2



Diode pumped solid state laser at 457 nm with up to 10 W output power
Source: PhotonTec Berlin UG



Fiber coupled diode laser at 808 nm, 9 xxnm and 1470 nm with an output power up to 400 W
Source: PhotonTec Berlin UG

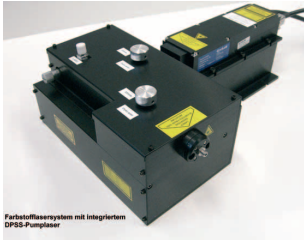

Dye laser system with integrated DPSS pump laser

Source: CryLaS Crystal Laser Systems GmbH

Diffusion-welded laser crystals

Source: Crystal GmbH

6.2

first industrial CW DPSS laser with 266 nm wavelength. In 2000, the American Spectra Physics took over LAS, which in turn was taken over by the U.S. photonics company Newport.

Today, Newport Spectra-Physics focuses on the development and production of diode-pumped solid state lasers for industrial applications, especially in the green and ultraviolet spectral range. The integration in the Newport Group provides access to the entire peripheral equipment required for industrial use, from fiber optics to positioning devices. Newport Spectra-Physics works with many scientific facilities in the region, such as the Fraunhofer Institute for Applied Polymer Research (IAP) in Potsdam-Golm.

Laser technology and related areas have been main focuses in Berlin-Brandenburg since the utilization of the concept itself. Many regional companies benefit from this decades-long experience. For example, the employees of the Innovative Berlin Laser GmbH (IBL) have been doing research in this area since about 30 years. Today, IBL primarily offers diode lasers, but also flashbulb-pumped solid state lasers. IBL mainly works as a supplier. Customers are, for example, companies in the fields of material processing, defense, medical technology and science. Therefore, IBL concentrates on developing compact and robust systems which are easily integrated into customers' products. Laser markers ranging from five to 100 watts, high performance systems in the 100 watt range and systems with long pulse duration and high single pulse energies up to the 100-millijoule range are some of IBL's products.

Further specialists for diode-pumped solid state lasers are Compact Laser Solutions and Crystal Laser Systems, short CryLaS. Compact Laser Solutions has specialized in long-lasting ultra-compact systems for industrial use. Their Blade series for instance promises the combination of the advantages of solid state and fiber lasers. The systems' compactness results, among other reasons, from pure air cooling. They are applied for direct marking and coding of products, material processing in the micro and macro environment, from drilling and cutting to glass engraving. As a supplier, CryLaS also produces for industrial customers and science. CryLaS offers solid state lasers as well as dye lasers. The available wavelengths cover the entire spectrum from ultraviolet to infrared. Applications are found, for example, in biotechnology,

medical technology and micro material processing. The CryLaS subsidiary Secopta operates in the fields of security and analysis. In 2007, Secopta received the Technology Award of the German defense industry for a laser-based land mine detection system.

Short Distances for Laser Manufacturers and Users: Suppliers in the Region

Of course, Berlin-Brandenburg could not have become a leading region in terms of laser technology without qualified companies supplying components for enhancing the laser as an industrially or scientifically usable module. And there are many of these suppliers in Berlin-Brandenburg.

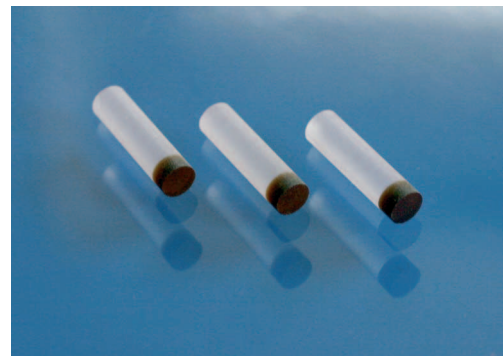

The Angewandte Physik & Elektronik GmbH APE in Berlin, for example, is the international market leader for components and systems in ultrafast laser technology. Its portfolio ranges from autocorrelators via components for wavelength conversion to spectrometers, from acoustooptics to optical parametric oscillators. Crystal components, for example for the construction of YAG:Nd and YAG:CR lasers, are supplied also by the Crystal GmbH in Berlin. In addition, the company offers active and passive laser components and optical components, for example from fluorides, silica, quartz and glass.

The Berliner Glas KGaA Herbert Kubatz GmbH & Co. has specialized in high quality optical components. Berliner Glas develops customized optical systems. It manufactures lenses, prisms, gratings and other high quality components in the clean room, provides complete optical, opto-electric and opto-mechanical systems and integrates optics in customer projects.

Frank Optic Products is specialized in fiber optics, reflectors, optical cables, and sapphire and quartz optics. Systems are developed to customer specifications. Customers include companies in laser and medical technology, the automotive industry, signaling and lighting engineering. Optical fibers and fiber systems are also the business area of A.R.T. Photonics. This company provides systems for a wavelength range of 180 nanometers to 18 micrometers. A.R.T. products are applied in spectroscopy, for biopsies and in laser medicine. OsTech specializes in laser



Blade series

Source: Compact Laser Solutions GmbH

Diode-pumped solid state CW UV laser

Source: CryLaS Crystal Laser Systems GmbH





Clean room production at
Berliner Glas

Source: Berliner Glas KGaA
Herbert Kubatz GmbH & Co

6.2

diode drivers for amperages from 1 to 400 ampere and voltages from 2 to 60 volts. The devices can be combined in a modular way; special configurations, such as redundant or continuously available systems are also offered.

External know-how is easily purchased in the region. Independent developers, such as Optikexperten (Optics Experts) Dr. Volker Raab, help assemble and optimize suitable systems. Raab was the founder of the chair for photonics at the University of Potsdam. Since his retirement he now offers assistance with his own laboratory, especially for research on semiconductor lasers and optics for beam shaping and fiber coupling.

Without doubt, only where all players – developers, researchers, laser manufacturers and suppliers – work together across short distance are new technologies continuously developed. Only then can production costs, lifetime, space requirements and energy consumption be optimized for existing products. This is the case in Berlin-Brandenburg. Or, as expressed by eagleyard co-founder Jörg Muchametzow: "The region is certainly one of the most interesting laser technology centers in the world."

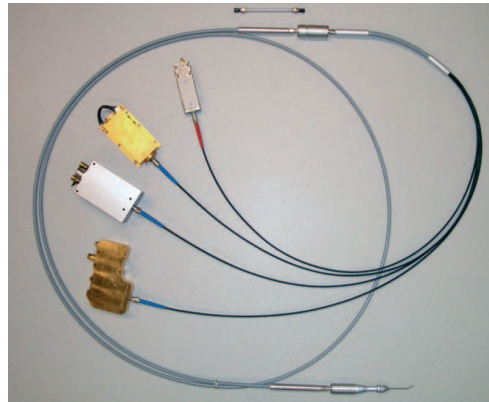

Three diode lasers, bundled,
plus pilot laser, refocused in a
homogenizer and finished with
a hand piece

Source: A.R.T. Photonics GmbH

Glass processing with LMTB
trepanning optics for the
production of a long cylindrical
hole via ns laser pulses (532 nm)

Source: Laser und Medizin-Technologie
GmbH, Berlin (LMTB)

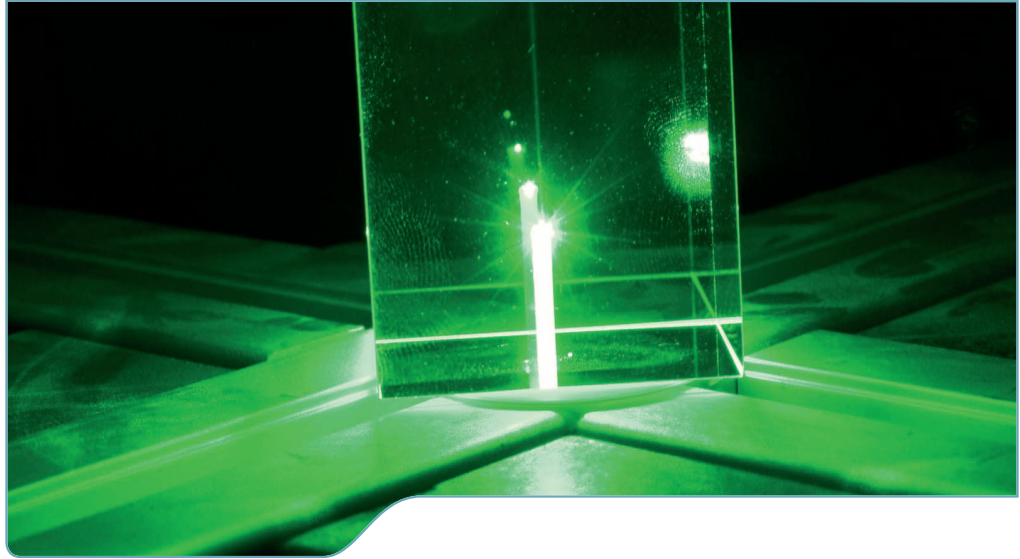

Kai Kolwitz

6.3

Material Processing

Bonding, Disjoining and Modifying - Laser Material Processing in the Capital Region

An ytterbium fiber laser with 20 kilowatts of power, a few rooms further a disc laser generating up to 16 kilowatts ... those who wish to experience some of the strongest lasers in action in Germany should schedule an appointment at the Federal Institute for Materials Research (BAM): Unter den Eichen 87, Berlin-Lichterfelde.

The BAM is equipped with this technology because of its responsibility to ensure that requirements for weld joints in thick-walled and safety-critical modules are being met. An example are the weld joints of gas pipelines running below extremely densely populated areas. A twelve-person team, managed by Professor Michael Rethmeier, Head of the BAM branch "Safety of Joined Components", deals with issues in the field of laser and laser hybrid welding. The working group interprets its task very actively and works closely with the industry. Jointly, existing methods are examined in terms of safety hazards. One also searches for new methods and parameters for reliably and productively joining thick-walled components via laser and hybrid welding processes. One focus is the joining of steels of different qualities. Another, the question of how the position of the weld optics relative to the material in cases of 3-D welding an immobile component affects the quality of the bond; the orbital welding device for such experiments is, of course, also available.

Other components currently in the focus of the BAM

researchers are hydraulic cylinders. They are highly stressed and currently still mostly drilled or cut from solids. However, the introduction of laser-hybrid welding processes could generate significant savings. Pipes would only have to be thick-walled in places where a lot of material strength is required. The Federal Institute for Materials Research clarifies the details: How much component shifting is tolerable? And how thick can a component be in order to be welded with a 20 kW laser?

The BAM branch is not the only group in Berlin and Brandenburg to intensely work on improving methods of laser material processing and making them available for new applications: How are very different materials joined by lasers? How are thermal problems handled when there are large differences in the thickness of the materials? And how are connections built so that they are easily separated in the case of repair or at the end of a car's life?

At first glance, the many research activities on methods for laser material processing in Berlin-Brandenburg may seem a bit confusing. There is indeed little automobile industry, which many still associate with laser welding. But there are also large users in the German Capital Region. Among others, there are lighting manufacturer Osram as well as Siemens in Berlin-Spandau, where turbine components are manufactured, with facilities virtually on a par with those of the BAM. Mercedes builds cars in Ludwigs-

felde in Brandenburg and Rolls Royce builds aircraft engines in Dahlewitz, at the outer beltway of Berlin. The transmission specialist ZF is located in Brandenburg on the Havel. MTU Maintenance and Viessmann are also represented. The solar industry, which has reached the billion Euro turnover benchmark in the region recently, uses lasers for cutting and trimming cells. In Berlin, the razor manufacturer Gillette sets more than a billion welding points per year via laser for connecting blades with carriers.

Laser Tools for Material Processing

Whoever manufactures via laser in the region can do this with technology developed in Berlin and Brandenburg – no matter if large quantities or individual processing of workpieces is needed.

Highyag, situated in Stahnsdorf near the Berlin city limits, is one of the world's leading companies for tools used in laser material processing. They offer laser processing heads for welding, soldering, cutting, coating and drilling, and for beam transmission systems and accessories, such as ancillary equipment for the adjustment and set up of processes. Depending on the model, laser heads are designed for up to 500 watts, two kilowatts, four kilowatts, six or even 20 kilowatts. Highyag develops customized tools and trains customers' employees. Scansonic has established its reputation especially with its mechanical and optical seam tracking systems. They are applied, for example, in body construction in the automobile industry and are integrated into laser processing heads and adaptive platforms of the company. Scansonic products operate with solid state, diode and fiber lasers. They are recommended for welding and soldering thin sheets, in two- and three-dimensional contours.

Compact Laser Solutions is best known for laser modules applied for marking and coding in the industrial context. The modules offer an ultra-compact design, achieved by, for example, pure air cooling

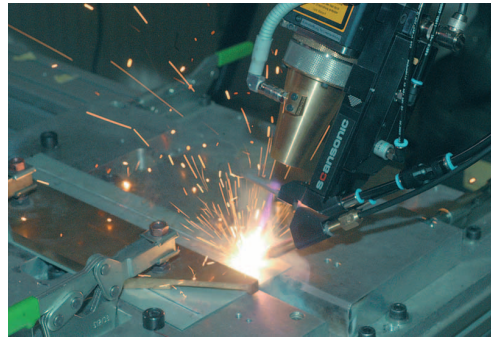

Lap joint laser beam welding body

Source: Scansonic IPT GmbH

and are applicable for trimming, drilling, cutting, deep engraving and structuring. Almost all inorganic and certain organic materials can be used as processing materials. The latest line of products is the Blade series. Available wavelengths are 1064 nm and 532 nm, with an average power range of up to 40 W (1064 nm) and pulse frequencies of up to 500 kilohertz. Compact promises good results, even when processing unwieldy materials such as gold, copper, glass and diamonds. The DuoBlade, which was introduced in July 2010, is the first industrial laser system to be operated optionally at a wavelength of 1064 nm and 532 nm or 1064 nm and 355 nm.

IBL Innovative Berlin Laser provides diode-pumped solid state lasers with Q-switching, power up to 800 watts and pulse energies of one milli-joule (1064 nm), 250 micro-joules (330 nm) at repetition rates of up to four kilohertz. At 500 hertz and 1064 nm, 800 milli-joules are delivered. Four different pulse length ranges are available: 10-50 nanoseconds, 20-140 nanoseconds, 100-500 nanoseconds and 400 nanoseconds to 1.5 microseconds.

The pulsed laser welding system KPL 5000 from Komlas in Berlin is used for laser micromachining. The KPL 5000 is maintenance-free and can be delivered with two fiber outputs for simultaneously setting two welding points. A stereo microscope can also be integrated. At a wavelength of 1064 nm, the system delivers a pulse energy of up to 5,000 milli-joules, the average power output is five watts. Komlas also offers optical components, laser cavities and crystals and a diode-pumped Nd-YAG system for training and education purposes. The system's parameters are modifiable and enable various experiments.

Canlas in Wildau in Brandenburg is specialized in micromachining in the areas welding and inscription. Canlas technology welds semiconductor chips on heat sinks, but also labels medical instruments or engraves datamatrix codes on printed circuit boards. The self-developed marking systems are based on Nd:YAG lasers and available with output powers from three to 50 watts. The welding system is suited for various materials and operates with a lamp-pumped Nd:YAG laser, which can also be used for drilling or perforating. A microscope can be coupled to the system.

6.3

Lap joint laser beam brazing body

Source: Scansonic IPT GmbH

Smart Laser Systems' MiLaBS is also a micromachining system. The product name stands for a complex laser system realized with minimum volume; it is ideal for flexible applications. This processing system is also coupled to a stereo microscope. It combines computer controlled processing of very small structures with excellent visual control. In addition, Smart Laser Systems provides diode cooled solid state lasers with a compact modular design. They are, for example, well suited for welding and offer output powers of more than 20 watts. In addition, Smart Laser Systems offers laser heads for an entry into diode laser technology.



Beam source for material processing
Source: Lumics GmbH

technology. Due to the strong concentration of light, laser soldering is recommended especially for fine soldering points and, in general, where little space is available for the solder joint.

Technology, Consulting and Production from One Source

It is noteworthy that many companies in the region manufacture or design laser processing systems for customers and, at the same time, manufacture as a service provider to customer's order. One example is Photon Laser Engineering in Berlin. The company develops and tests new material processing methods via laser: cutting, welding, soldering and coating, especially for the production of car bodywork and technology and rail, air and space vehicles. It analyzes production tasks, finds solutions, implements the applications at the customer's site and trains the customer's staff.

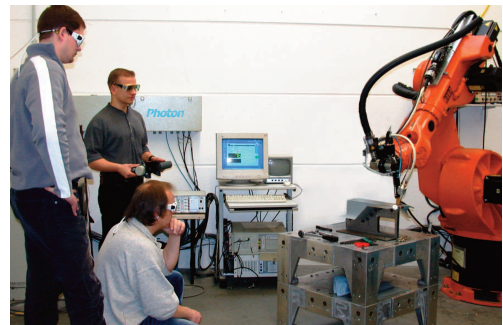

The know-how is also applied in their own production, both in Berlin Spandau and in Schönwalde-Glien in Brandenburg. Photon Laser Manufacturing builds sheet metal parts which can be cut, drilled and assembled via lasers. Photon Laser Manufacturing also works for the automotive industry, railway vehicle manufacturing and aerospace. The Berlin companies itec Automation & Laser and Laser-Mikrotechnologie Dr. Kieburg have several mainstays. On the one hand, itec manufactures laser machines for cutting and welding and special machines for complex manufacturing processes based on the laser machines. On the other hand, the company produces prototypes, advanced prototypes and regular production series for its customers and also

6.3

Training with a high-performance solid state laser
Source: Photon Laser Engineering GmbH

Laser beam brazing training
Source: Photon Laser Engineering GmbH

Others also focus on diodes for material processing. With their increasing power, Lumics's diode modules continue to open up new application fields. Laser Electronics develops and manufactures high-performance laser systems for pumping solid state and fiber lasers for material processing and industrial and general laboratory applications. Laser Electronics provides both individual components and complete laser diode systems including lasers diodes, fiber and optics. Laser diode systems are available with up to 250 watts, 200 to 600 micrometers fiber diameter and wavelengths of 808, 880, 915, 938 and 976 nanometers. Furthermore, Laser Electronics offers the technical periphery, such as the laser diode controller LDC1000, a laser diode driver and TEC driver combined in a single device. The laser diode driver delivers both CW and pulse currents, and hence provides up to 150 amps to high-power laser diodes, laser arrays and laser stacks. The integrated TEC driver powers Peltier coolers with up to 600 watts. Of course, the laser can also be used to solder. ATN Automatisierungstechnik Niemeier is specialized in automated systems for single-point soldering. The company's soldering technique is based on diode



High-performance laser diode system
Source: Laser Electronics

performs follow-up work such as bending or surface treatment. itec vmax laser machines are characterized by linear motorized precision axes which also enable three-dimensional work, depending on the design.



Laser-Mikrotechnologie Dr. Kieburg advises its clients on concepts, and it develops and produces systems for laser micromachining, from OEM modules via stand-alone solutions to complete processing systems. These systems can produce photo templates, fine metal masks, labels, and pinholes, process silicon, ceramics and metal three-dimensionally and, of course, microstructure, label and drill materials and fine-blank metal foils down to the micrometer range. Then again, the above-named operations are also offered by the company as a service provider for industries from engineering via automotive to advertising and visual arts. Pieces such as a penny coin with a child's face engraved by laser are shown for advertisement purposes. Welding of stainless steel and unusual material combinations are also in the repertoire.

The engineering company Hüyüktepe, Helios Laser-Service, is also active in two areas. It designs, builds and maintains laser systems, and trains in their operation. In addition, it offers its own finishing technology for cutting, welding, drilling, scribing, labeling and the removal of coatings – from the macro to the micro range and in 2D and 3D.

DoroTEK in Strausberg distributes components from the Polish Solaris Group: laser labeling systems, optical components and Pockels cells for beam modulation. The company also operates as a paid service provider in terms of laser labeling for promotional and industrial products of all kinds and on almost every imaginable material. Repair of parts from widely different areas via laser welding, laser labeling and 3D laser engraving on various materials are the business areas of Delta Laser Tech in Berlin.

Specialists in Micromachining

The range of service providers for laser material processing is large in Berlin and Brandenburg. Not only broadly based companies, which offer a wide range of production work in the micro and macro level, but also specialists are located in the region.

One of them is Laser Micro Präzision, based in Teltow. Laser Micro Präzision works in the micro area and offers, for example, laser labels down to the micrometer range, for instance for data matrix codes on printed circuit boards. In addition, the company is specialized in micro-surface treatment, such as the modification of chrome-glass masks for lithography or subsequent uncovering of defined areas on coated surfaces or the modification of microstructures of the surfaces of work pieces and, thus, the modification of their properties. Even drillings in the 0.1-millimeter range are possible. The procedures for the offered services are continuously further developed by Laser Micro Präzision.

escotec Lasertechnik, also based in Teltow, has a core competency in the micro-area, too. The company is specialized in laser welding of micro-components, especially for medical technology. For example, cannula tubes can be connected starting from wall thicknesses of 20 microns, and stainless steel and titanium films starting from five microns. In addition, customized component geometries for medical applications such as micro-containers for radioactive sources are developed.

The Berlin company acolma, on the other hand, has focused on athermal micromachining via laser – manufacturing of surface structures in the micro- to nanometer range, the amorphization of surfaces, drilling of micro-channels, the production of channels parallel to surfaces or drilling of curved channels. acolma is capable of working with all solid materials.

Pac Tech – Packaging Technologies, based in Nauen, uses laser technology for the production and refinement of wafers, microchips and circuit boards. Pac Tech solders pre-fabricated solder balls via laser at customer's order and refines pad surface microchips. Also, fully automated machines for the finishing of silicon wafers and micro bonding technology based on laser soldering and welding are developed and built. The company works for major clients in telecommunications, the automotive industry and various areas of electronics manufacturing in both fields.

Broadly-based Regional Research Environment

Many of the developers, manufacturers and service providers in the Berlin-Brandenburg region are highly innovative. This is possible, not least because the regional scientific environment in terms of laser material processing is extremely diverse.

Laser-based techniques are very important in re-

Laser micromachining system LMB5 micro laser

Source: Laser-Mikrotechnologie
Dr. Kieburg GmbH

6.3

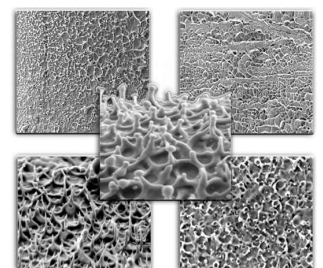

Surfaces

Source: acolma GmbH

6.3

search in the fields of joining and coating technology at the TU Berlin. In aircraft and automobile construction for example, modern joining processes are needed for the creation of high-strength, yet light-weight structures made of different materials. Coatings function as corrosion protection, increase the service life of tools and provide heat insulation. Also, techniques such as cladding enable the repair of high-priced components.

Head of the Department is Prof. Johannes Wilden, who moved from the Technical University Ilmenau to Berlin with his team. One of his projects is "Proremix". It focuses on finding joining concepts which consider the entire life cycle of a module made of different materials. Not only Wilden's research group, but also companies such as Audi or Porsche are involved in the project. The partners are looking for answers to the question of how to create durable connections of, for example, steel or titanium with aluminum or between steels with different solidities.

Another focus: once such modules are installed, for example in car chassis, they must be serviceable with reasonable effort and separated and correctly recycled when the vehicle reaches the end of its life.

Wilden's group strives to reach these goals via techniques such as laser hybrid processing. Sought after are connection media with a melting point so far below those of the actual components, despite high solidity, that they can be thermally re-separated.

New applications for laser techniques are spotted at the department when, for example, materials, to date considered as non-weldable, have to be joined: brass and steel, titanium and aluminum, titanium and stainless steel. Future applications could lie in medical technology or precision engineering. The service life of aluminum die casting tools can also be multiplied by laser coatings. Also in focus: how are successful laboratory experiments distilled into production processes suited for industry? How can the companies' quality and reproducibility requirements be met? And how can expenses be lowered?

The Brandenburg University of Applied Sciences also does research on not yet feasible connections. One

emphasis at the Center for Laser Material Processing at the Department of Engineering is on wires. This involves a number of problems which might occur when welding wires of different thickness to each other or to other components. The researchers try to minimize the heat influence via short pulse welding. Pulse shaping is also a focus. For example, short high energy input enables the removal of insulations in advance. Also studied are pulse geometries ideal for connections of different materials.

In the experiments, the researchers work with wires with diameters of sometimes only 0.01 millimeters. For example, an electrically conductive connection between a 1 mm thick stainless steel wire and a 0.3 mm thick copper wire insulated with a coating succeeded. In spite of an insulating coating, tinned copper material with a diameter of 0.8 mm on one side and a copper strand with five individual wires with a diameter of 0.04 mm on the other side could also be connected. It is assumed in Brandenburg, that results can still improve considerably.

These are only two of the many examples in the region. The Department of Electrical and Precision Engineering at Beuth University of Applied Sciences (formerly Technical University of Applied Sciences Berlin) is developing new techniques for laser soldering and welding.

The Fraunhofer Institute for Production Systems and Design Technology (IPK) is studying methods for laser and hybrid welding. The Institute is also involved with the question of how hard laser cutting tools, such as those made of diamond, can be sharpened via laser. Pulses in the picosecond range could help smooth the material and provide it with surface properties enabling a defined chip breaking. The Institute of Optics and Atomic Physics of the TU Berlin does research on near-infrared lasers for glass processing, as well as on techniques for percussion drilling, the drilling of materials by pulsed laser radiation. The Department of Machine Tools and Factory Management at the TU Berlin is searching for possibilities to smooth medical implants via laser beam.

Laser- und Medizintechnik Berlin (LMTB) is also closely linked to research facilities in Berlin and Brandenburg. The non-profit institute collaborates with all three universities in Berlin. In the field of material processing, it conducts application-oriented research on new techniques for precision and micromachining of metals, semiconductors and ceramics. Examples of research activities are projects for the removal of thin layers or the unstressed sub-surface marking of glass.

LMTB also concentrates on the minimization of heat influence and tensions developed while drilling micro-holes, and it works on techniques for the precise and careful division of solar cells. This research is conducted with the goal to provide it for upco-

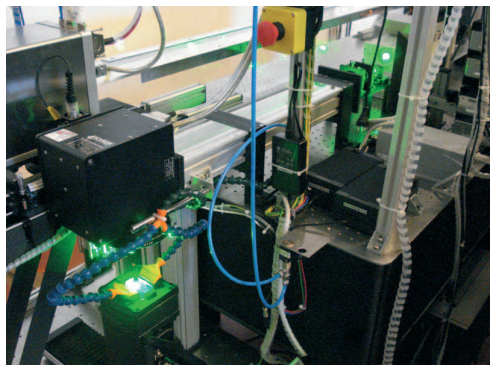

Finishing via diode-pumped Nd:YVO₄ laser at 532 nm
Source: FH Brandenburg

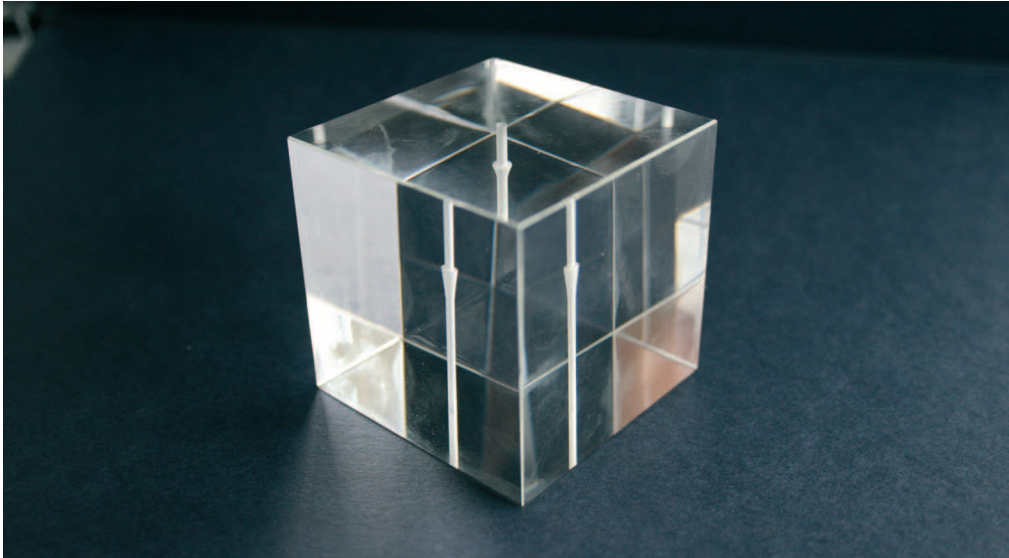

Drilling with a conical bulge via trepanning optics

Source: Laser- und Medizin-Technologie GmbH, Berlin (LMTB)

ming industrial applications. Therefore, not only precision but also considerations of speed and costs are already required during research. In the solar sector, Laser- und Medizintechnik Berlin (LMTB) has, in the past, succeeded in developing a laser-based scribing technique. For the first time, it was possible to separate mono and polycrystalline silicon wafers cleanly without lowering the photo voltage of the cells and reducing their efficiency.

Laser Material Processing Give Away

Laser material processing made in Berlin-Brandenburg is also nicely placed in the cabinet at home – and it can look very decorative, e.g. with products

of Crystalix Evolution. The company has specialized in sub-surface engraving and works with self-developed machines. Crystalix Evolution engraves photos, three-dimensional portraits, company logos and other designs in the interior of a glass block. This is possible, for example, at the company’s shop at the Potsdamer Platz. Those who prefer buying jewelry as a gift could, without knowing, return home with a piece of laser material processing. Goldsmiths, such as Strahler & Schuld in Berlin, actually apply laser techniques for jewelry production.



Drilled holes in glass at an angle via trepanning optics (top)

Luminous effect while processing ceramics via ps-laser (bottom)

Source: Laser- und Medizin-Technologie GmbH, Berlin (LMTB)

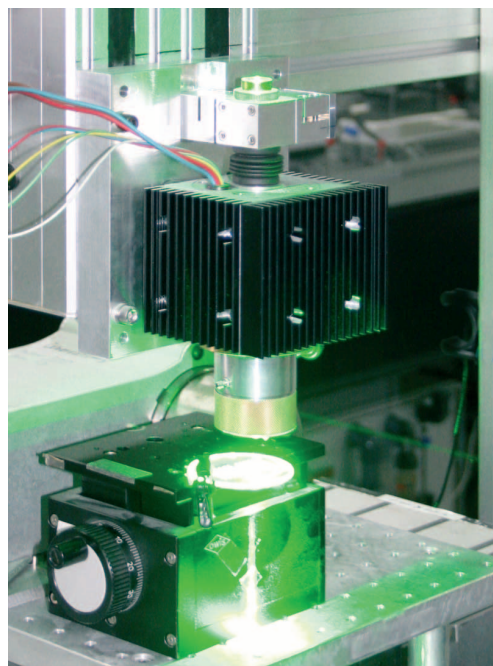

Trepanning optics in glass processing with frequency-doubled NdYAG ps-laser (532 nm)

Source: Laser- und Medizin-Technologie GmbH, Berlin (LMTB)

Smaller than a matchbox:
microsystems light source
for FreshScan

Source: Ferdinand Braun Institute,
Leibniz Institute for Highest
Frequency Technology
© FBH/schurian.com

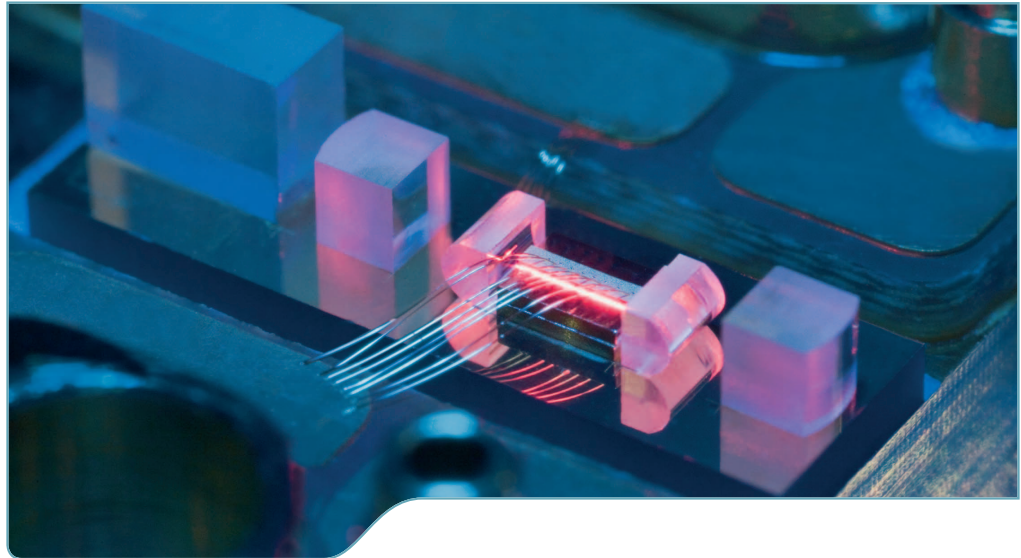

Kai Kolwitz

6.4

Measurement Technology and Analytics

Measurable Quantity - Laser Measurement Technology and Analytics in Berlin-Brandenburg

A laser which helps detect spoiled meat? For some, this might sound strange at first. But several "rotten meat" scandals have highlighted the issue. And this idea is just one example for the numerous applications laser spectrographic procedures offer.

The principle behind laser spectroscopy, and thus behind food examination, is easy to understand: Each material absorbs, scatters and reflects laser light differently, atoms can be excited and then emit radiation. And all this is measurable.

Meat changes its material when it ages, so the results of spectroscopic studies also change. The project "FreshScan" is developing this idea and is pushing it into practical use. Involved are the Institute of Optics and Atomic Physics at the TU Berlin, the Ferdinand Braun Institute, Leibniz Institute for Highest Frequency Technology (FBH), the Fraunhofer Institute for Reliability and Micro Integration (IZM) and several other research institutions in Berlin and Brandenburg.

Scientists have developed a combination of Raman and fluorescence spectrography for examining meat. Raman spectroscopy makes use of a specially developed optical system with an integrated red-emitting diode laser. The scattered Raman Stokes photons are fiber optically detected in an evaluation unit and statistically analyzed via computer. In fluorescence spectroscopy, meat is irradiated with a laser in the blue spectral range and the results are evaluated in

a similar manner.

The project staff for "FreshScan" initially conducted its research with pork meat. However, it is convinced that the process can also be applied to many other foods. In order to use "FreshScan" not only as a pure laboratory procedure, but also in the cold warehouse or supermarket, a suitable scanner was needed. The result of their efforts is a "laser gun", a convenient portable scanner, which is directed at the good to be examined and directly shows whether it is edible or spoiled.

Laser spectroscopic methods provide almost infinite possibilities. Many research institutions in Berlin and Brandenburg are working on the development of these methods and new application fields: The Fritz Haber Institute of the Max Planck Society and the Max Born Institute for Nonlinear Optics and Interface Spectroscopy conduct basic research on the subject, the Institute for Analytical Sciences (ISAS) examines human DNA spectroscopically, the Max Planck Institute of Colloids and Interfaces develops spectroscopic methods enabling applications in areas from biotechnology to measurements of concrete. These are only a few of the many examples.

Lasers Detect Land Mines

Lasers also play an increasingly important role in environmental analysis. For example, the Berlin-based company Secopta offers portable detectors for pollu-



Design sketch of the scanner
for testing freshness

Source:
Fraunhofer Institute for Reliability
and Micro Integration IZM

tant analysis via "Laser Induced Breakdown Spectroscopy", short LIBS.

Secopta is a subsidiary of the company CryLaS in Berlin and builds its products upon CryLaS's lasers. Secopta detectors work with short, high-energy laser pulses. They make sure that the sample to be analyzed is heated to some 10,000 degrees. The resulting plasma radiation can be captured and analyzed. An analysis of the spectral lines of the emitted radiation reveals which substances are found, for example, in contaminated soil.



Secopta systems can also be applied for scrap metal sorting or industrial process control. The original purpose of the company, however, was the development of technology for the search for land mines and explosives. In 2007, the company received the Technology Award of the defense industry. Awarded was the development of a "laser optical mine prodder", developed by the Secopta GmbH together with the LaserApplicationCenter (LAC) of the TU Clausthal and the Bundeswehr Research Institute for Materials, Fuels and Lubricants (WIWeB). Secopta technology combines a proven mechanical technique with laser spectroscopy. Thus, false alarms are reduced and more precise knowledge of the type of mine is gained prior to excavation.

The LTB Lasertechnik Berlin is also active in terms of safety. The company's systems are applied in scientific and industrial contexts. At the 2006 World Cup, a system for the protection against attacks was presented together with the glass manufacturer Lanxess and the Society for the Promotion of Applied Computer Science, which is also located in Berlin. The system coats surfaces to be monitored with an invisible varnish which fluoresces in laser light.

When a treated area is manipulated, for example, a sewer cover is raised near an embassy without permission, the coating is damaged. When irradiated with laser light this becomes evident. This technique can also be installed in helicopters or cars, allowing fast checks even of large areas.

In addition to such technology, LTB provides short pulse lasers in the complete optical spectral range, and – not least – nitrogen and dye lasers. These form the basis for high-resolution spectrometers built at LTB, especially for LIBS and Raman spectroscopy and

laser optical measurement systems. Application areas of the LTB technology besides the security sector are, for example, material analysis and quality control. Adlares, located in Berlin, has also specialized in special analytics via laser spectroscopy: The main product is a detection module which can inspect gas pipes for leaks from a helicopter. The technique was developed by Adlares in cooperation with the company Vistac, based in Teltow (Brandenburg).

For this purpose, a GPS-guided infrared laser pulse is aimed at the gas pipe. The wavelength of the laser light is chosen so that it is absorbed by the main component of the gas. This is followed by a control pulse of a different wavelength. Detectors determine which portion of the light is scattered back to the helicopter – even small leaks can be detected. The E.ON Group applies this technology from Berlin to control its gas pipelines. In a modified form, it is mounted on Gaz de France vehicles which search for high gas concentrations in urbanized areas.



Available on Site: Components and Metrology

The fact that various manufacturers of components for spectroscopy and other laser measuring methods are based in the region supports companies and scientists in Berlin and Brandenburg in terms of developmental work.



Analysis system LIBS SORT

Source: Secopta GmbH

Copper pellet in the laser beam

Source: Secopta GmbH

6.4

Samples under the laser head

Source: Secopta GmbH

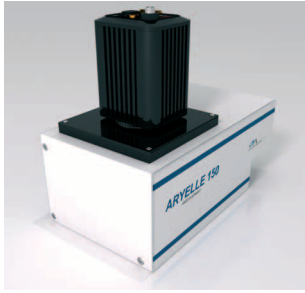

Spectrometer from the very high resolution Echelle spectrometer series ARYELLE

Source: LTB Lasertechnik Berlin GmbH

Many generalists, such as Jenoptik Diode Labs, Lumics, Berliner Glas, eagleyard or Frank Optic Products, provide components suitable for the development of laser measuring devices for spectrometers, atomic clocks or GPS satellites, ground control stations and more. IBL Innovative Berlin Laser's solid state lasers are applied in research in aerospace and are used in lidar systems.

There is also a large number of specialists: Advanced Laser Diode Systems A.L.S. offers short pulse laser systems for spectroscopy and surface analysis. PicoQuant manufactures complete fluorescence spectrometers, and L & M Laser- und Messtechnik in Werder / Havel is also specialized in this area. The products of Becker & Hickl are even more specialized. The company focuses on Fluorescence Lifetime Imaging Microscopy, short FLIM. In this time-resolved procedure, not fluorescence itself, but its time course is

fluorescence, are manufactured. A multi-function reader for multi-well plates is also available.

But laser measurement and laser monitoring technology can also follow simpler principles: for example in volume measurement systems provided by the U.S. manufacturer Accu-Sort, whose European headquarters are located in Kleinmachnow near Berlin. A combination of a CCD camera and a laser diode is applied for scanning and triangulation, and thus for automatic determining of package volumes. Lasers are also used in bar code scanners from Accu-Sort.

The Polytec GmbH in Berlin sells measurement systems for the analysis of vibrations, speeds, lengths and surface topographies. The company is a world market leader in many of these areas, and also offers spectroscopic measurement systems and complete solutions for measurement technology. The

6.4



Contact-free vibration measurement technology via Polytec Laser Scanning Vibrometer (PSV)

Source: Polytec GmbH

central. This technique even enables experiments at the level of individual photons. Becker & Hickl's technology is based on systems from Zeiss, Leica and Olympus.

In addition, systems for photon counting, detectors which can absorb up to 16 FLIM signals simultaneously in different wavelengths, diode lasers in the picoseconds range and other detectors for photon counting are offered.

Innovative Optische Messtechnik IOM, based in the Science and Technology Park Adlershof, also provides measurement systems for fluorescence analysis. Among other things, fluorescence spectrometers with nanosecond time resolution, detectors recognizing native fluorescence and technology for process monitoring, also operating on the basis of measured

Berlin-based Nanotechnik und Design GmbH helps developers and industry as a service provider in terms of laser optical valuation methods.

The Laser Beam Itself is also Measured

The applications of laser measurement technology developed in Berlin and Brandenburg are even more diverse: For example, the Institute of Planetary Research at the German Aerospace Center (DLR) is working on far-infrared spectrometers. The institute hopes to gain new knowledge about the formation of stars and planets by measurements in the terahertz range. Last year, the institute was able to create a map of the moon with unprecedented precision with the help of a laser altimeter aboard a moon probe. A laser scanned the celestial body and mea-

sured the time until reflections were picked up. The result: 5-meter accuracy instead of approx. 100, as before.

Both the Institute of Optics and Atomic Physics at the Technical University and the Institute of Experimental Physics at the Freie Universität are researching on and with LIDAR, "Light Detection and Ranging", which measures distances and speeds similar to the radar. Goals are to refine the technique itself, but also to receive insights on, for example, cloud formations and aerosol concentrations in the atmosphere via LIDAR.

The Ferdinand Braun Institute also has a working group for laser metrology. It works with laser-based measurement techniques and develops ultra-narrowband lasers which can be used for standardization purposes or for optical precision spectroscopy, such as applied in atomic clocks.

And there is, of course, another research and testing institution in Berlin specialized in laser measurement techniques: the Physikalisch-Technische Bundesanstalt, PTB. It is regarded as the German institution in terms of metrology, standardization and calibration. Represented in Berlin are the working areas "Thermal and Synchrotron Radiation" and "Medical Physics and Metrological Information Technology". The institute conducts basic research, but also works very application-oriented.

In the medical field, the PTB in Berlin is concerned, for example, with the development of laser-flow cytometry. In this method, blood cells emerge one by one through the foci of several laser beams. Hence, the light scattering and, when using fluorescent dyes, laser-induced fluorescence can be registered for each cell. These property studies offer help in diagnosis and therapy control.

Another focus of the research at the PTB in Berlin is terahertz radiation. This radiation ranges in the frequency range between microwaves and long-wave infrared, thus at the threshold of what can be produced by laser. Terahertz radiation is applied in spectroscopy, analytics and astronomy. It allows nondestructive material testing, monitoring of food quality, environmental monitoring and – not least – security checks. It penetrates many organic materials, such as clothing and can also provide spectroscopic information on safety materials. However, terahertz radiation barely penetrates human tissue. The technology of the currently intensely debated body scanner is based on this type of radiation.

But before being translated into practice, precise measurements were taken to avoid health damage. The PTB was the first institution to tie a commercial terahertz laser to the international SI unit system and to measure its performance comprehensively. This was done in cooperation with the laser manufacturer, the U.S. company Coherent. The PTB used a cryogenic radiometer, the German primary standard

for power measurements of electromagnetic radiation. This shows that lasers can not only analyze and measure, but that their own properties must also be checked.

The Neuenhagen company Sensor- und Lasertechnik Dr. W. Bohmeyer is actively involved in the private sector in the Berlin area. It offers measuring heads for energy and performance metrology, display units and accessories. The technology is available as a standalone solution and also in the form of OEM products for the installation in commercial lasers. In addition, customized systems are offered in the OEM sector. Sensor- und Lasertechnik provides both sensors for pulse lasers with high pulse energy and high repetition frequencies and broadband sensors with high sensitivity.

Lasers Help the Blind

Lasers can also support people with disabilities in their everyday life. One example is a product of the company Vistac: a blind man's stick, which scans the area and warns about obstacles via laser. Emitter and detector in the handle of the stick detect reflections of emitted light in the upper body and head region. Warnings are made by vibrations in the handle. As a service provider, Vistac also handles development requests for industrial companies. The principle of the blind man's stick is now also used for applications in the industrial context, such as laser-based collision avoidance sensors.

So lasers cannot yet make the blind see, but they can help replace the missing sense and make visible much of what is hidden from the human eye. And the Berlin-Brandenburg region plays a leading role in this field.

6.4



Improved safety:
The long stick with integrated laser technology for upper body protection

Source: Vistac GmbH

Mobile micro scanner developed by LMTB for the application as a confocal LSM in a clinical environment

Source: Laser- und Medizintechnologie GmbH, Berlin (LMTB)

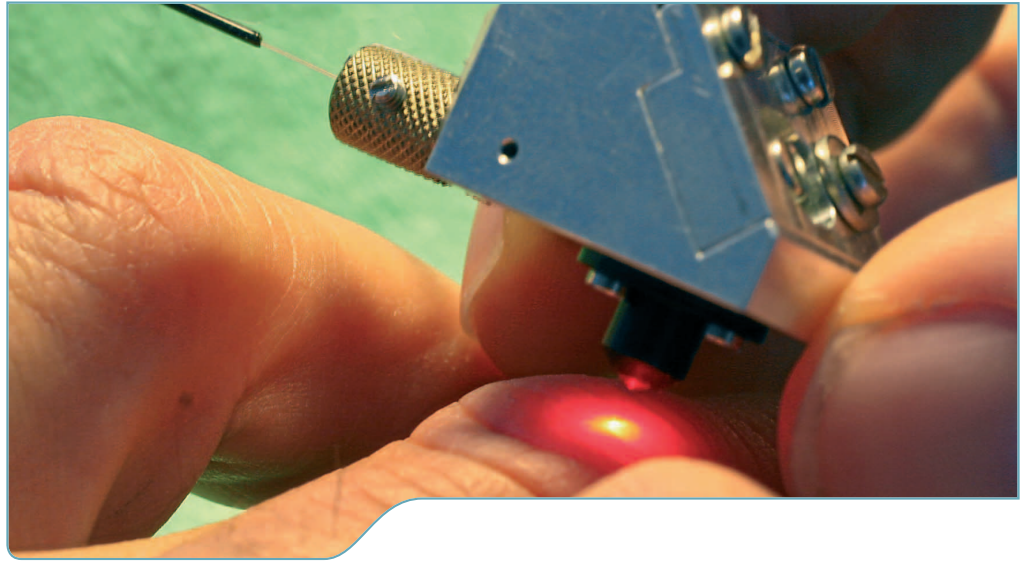

Kai Kolwitz

6.5

Medical and Biotechnology

Light Can Save Lives - Lasers from Berlin-Brandenburg in Medical and Biotechnology

Now it is a normal medical product: the model "Limes 16-P", manufactured by LTB Lasertechnik Berlin: a large box, a scanner arm, next to it a PC connected to two monitors. But this device can save lives. It is able to detect, even in the very early stages, whether a skin discoloration is harmless, or whether a spot indicates the dreaded black skin cancer. The diagnosis works with nearly 100 percent reliability, tissue samples don't have to be taken and analyzed in the laboratory.



Prototype Limes 16-P diagnostic device for early detection of skin cancer

Source:

LTB Lasertechnik Berlin GmbH

to address the issue. The non-invasive diagnosis of melanomas was considered difficult. Fluorescence spectroscopy, with which positive diagnostic experiences had been made in other areas, did not seem to work here. It was known that the early indicator, changes in the skin pigment melanin, was generally revealed by the fluorescence of the dye. But the signals were very weak; they were overpowered by other signals during the examination.

The Max Born Institute then discovered a usable absorption in the near-infrared range, at about 800 nanometers, but only when the dye atoms themselves and no atoms of the adjacent tissue were stimulated.

However, this was initially only possible with lasers with a pulse length in the femtosecond range (though the market-ready device ultimately works with nanosecond pulses). First, this technology had to be developed by the researchers and made available for practical use. From studies on skin samples, the path led to the development of a portable device which made it possible to examine the patient without having to remove samples with a scalpel. LTB Lasertechnik Berlin was also involved. It took about ten years from the start of the research to the market launch of the finished diagnostic tool. Around 2.000 people die of melanoma in Germany each year, and today the Limes P-16 is a big help in lowering this number.

This development marked a breakthrough in the fight against the deadly disease. And it is a good example of how research from Berlin and Brandenburg in cooperation with regional companies can be transformed into marketable products.

About ten years ago, Berlin's Max Born Institute for Nonlinear Optics and Short Pulse Spectroscopy began

Microcapsules and Blood Preservations – and What Lasers Have to Do With It

The Max Born Institute and LTB are certainly not the only ones in Berlin and Brandenburg to work on making laser technology usable for diagnosis and therapy. Laser spectroscopic methods, their development and utilization for new application areas are normal daily business in medical, biological and biochemical research institutions in the region.

At the Max Planck Institute of Colloids and Interfaces in Golm, Brandenburg for example, a number of projects in which the laser plays a role are running. Spectroscopy provides good services here, for example when it comes to studying smallest components. In Golm, research on microcapsules for the transfer into the human body is conducted. In the future, they could be used to precisely dock drugs to tumor cells. Surface enhanced Raman spectroscopy helps the researchers monitor the quality of the microcapsules.

Even when such capsules are already in the body, the laser can help. In Golm, microcapsules are transferred into the immune system of rodents. They have to be opened inside the cell to release markers – an infrared laser serves as a tool. This does not harm the cells, but makes nano-gold particles melt in the shell of the capsule and sets the markers free inside. In many of their projects, the researchers at the Max Planck Institute wish to learn from nature and mimic biological processes in other contexts and make them applicable. That's basic research, even though the implementation always succeeds amazingly fast. The geographic proximity of Golm to the Fraunhofer Institute for Biomedical Engineering (IBMT) is a great advantage. The main focuses lie in related areas: biochips, biosensors and nano-medicine. Lasers are used, for example, for nano-structuring and as a tool for research at the cellular level. Multi-photon laser microscopy is conducted via infrared femtosecond lasers.

Extremely practice-oriented is an institution in the medical research community of Berlin – the Laser- und Medizin-Technologie GmbH, Berlin (LMTB). The non-profit institute for research, development and training in biomedical optics was founded in 1995 by the merger of the Laser-Medizin-Zentrum (LMZ) and the Festkörper-Laser-Institut (FLI). It cooperates with the Charité, the three major universities of Berlin and many other research institutions in the region. The objective is to transfer the technologies into practice, as will be seen later in the example of laser lithotripsy (Freddy).

LMTB possesses outstanding competence especially in the areas of analytical and diagnostic imaging, minimally invasive therapy and laser precision machining. It also works on the use of fluorescence, absorption and Raman signals for diagnostic purposes and implementing them into imaging processes. The

importance of molecular diagnostics is increasing, since the insights of molecular medicine can be applied beneficially. One example from LMTB is the development of a method for the early detection of colorectal cancer without taking a sample. Correction algorithms for the elimination of the influence of the surrounding tissue on the measurement results are a part of this research.

The contamination of medical instruments can also be detected via fluorescence. And spectroscopic methods are suitable for blood diagnostics as well. The proportion of red blood cells, oxygen intake and blood changes are also detectable via scattering and absorption. In parallel, the institute conducts research on techniques for measuring tissue perfusion using the laser Doppler method. LMTB always has the transfer into practice in mind in their research, as shown by Berlin-made sensors for heart-lung machines and the examination of blood reserves through the bag. LMTB has also developed handsets, such as a mobile micro laser scanner, which works as a component of a laser-scanning microscope and can be used for skin and tissue studies.

Another research focus of LMTB is minimally invasive surgery via laser. Due to its thermal effect, laser radiation is even capable of selectively destroying tumors, for example in the liver. Such procedures are also researched in Berlin and transferred into clinical validation. To this end, LMTB usually cooperates closely with the Charité. This collaboration also generated the so-called "rheumatism scanner". The Columbia University in New York was also involved in its development. With this device, tissue changes are made visible by means of small changes in the distribution of scattered light on finger joints. Rheumatism or arthritis can thus be diagnosed at an early stage.

From Research to Practice – Suppliers in Berlin and Brandenburg

Whether tumor therapy, the removal of kidney and gallstones, the correction of eye defects or the removal of tattoos: in medical terms lasers have, in many areas, long outgrown the experimental stage and are found in many hospitals and medical practices. And the technology may well have been produced in Berlin and Brandenburg. Quite a number of manufacturers of medical laser devices are found in the region.

The name Linline, for example, stands for "Laser Instruments New Line". This company has developed several own procedures for the gentle use of laser radiation on the human body and was a pioneer in the medical application of pulses in the nanosecond range. The main product of Linline is the Multiline system, which consists of a mobile base system with various interchangeable laser heads.

Depending on equipping, Multiline is suited for a

6.5

Multifunctional laser system
Multiline™
Source: Linline GmbH



6.5

Laser fragmentation of body
concretions (here a gallstone)
via FREDDY® – technology
Source: Laser- und Medizin-Tech-
nologie GmbH, Berlin (LMTB)

wide range of applications: equipped with a Nd:YAP long impulse laser module, it functions as a laser scalpel which can, for example, remove scars or warts. A ruby laser is used for the removal of tattoos and pigmented disorders, the treatment of vascular diseases, laser hair removal or photo rejuvenation is possible with other attachments. Limmer Laser recently introduced the first high-power diode laser, which is licensed for medical purposes. The Diolas LFD Advanced can be used, e.g., for the treatment of tumors in the bladder or for indications concerning chest and abdomen. In these cases Limmer promises less bleeding than conventional Nd:YAG lasers and, therefore, faster operations and shorter recovery times. The LFD Diolas 3000, also a diode laser, is recommended for urology and uro-gynecology and is suitable for applications from the treatment of the prostate to the destruction of stones. Other Limmer lasers operate with CO₂ and Er:YAG media, such as a CO₂-based laser scalpel system, or devices for applications in dental or ENT medicine. Attachable scanner modules extend the treatment spectrum to the removal of wrinkles and acne, for example. The World of Medicine AG in Berlin offers medical lasers. World of Medicine's own Freddy laser technology on solid state basis, which derived from the basics developed by LMTB, is offered as an alternative to dye lasers. It reaches the pulse duration range

of 200 nanoseconds to 2.5 microseconds with laser energies of 100-250 milli-joules and, therefore, ranges exactly between Q-switched and free-running solid state lasers. World of Medicine's lasers are mainly used for the removal of gall- and kidney stones. However, other applications are also imaginable, such as surface cleaning or works of art. In addition, World of Medicine offers a fiber applicator which can be processed and is autoclavable, and therefore can be sterilized with normal hospital equipment.

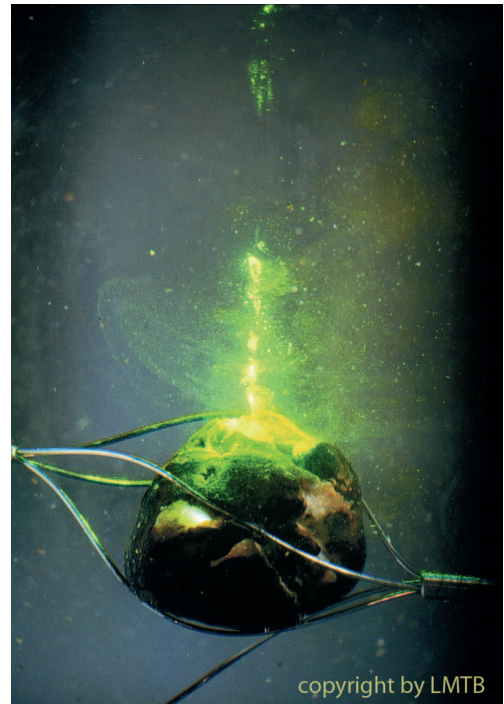

copyright by LMTB

Fibers for applications in medicine are also provided by Frank Optic Products. The company manufactures product lines developed with a view to reusability and automatic sterilization. In contrast to conventional fibers, they are made of materials resistant to hot water – hence beam guiding systems can be sterilized completely with the handle in an autoclave. This lowers consumption costs and facilitates handling. CryLaS also recommends its diode-pumped solid state lasers for medical and cosmetic applications. And LTB Lasertechnik Berlin also does not only offer the above-described system for the detection of skin cancer, but also laser sources and spectrometers for medical diagnostics. In the laser field, the product range includes several nitrogen lasers which radiate with a wavelength of 337.1 nm. For example, the MNL 300 UV provides up to about 16 kilowatts of peak power and a 300 hertz repetition rate. Also available are dye lasers such as the MWL 400 multi-wavelength laser. Some of the devices offer automatic tunability. Spectrometers are offered for LIBS and Raman spectroscopy.

Innovative Optische Messtechnik IOM, located in Berlin, is concerned with analysis technology for fluorescence spectroscopy and tissue diagnostics. IOM offers a fiber-optic fluorescence spectrometer with nanosecond time resolution and rack design. The device operates with fiber optic probes. The excitation of the samples can be varied from ultraviolet to the near-infrared range by changing filters. In addition, IOM produces a module for the highly selective analysis of the metabolism of tissue and cell cultures. The device also analyzes fluorescence.

It operates non-invasively and also with sterilizable fiber-optic probes, supplied and customized by IOM. Of course, the region offers further basic components for medical technology. Diodes and modules from local manufacturers, for example eagleyard, Jenoptik Diode Lab or Lumics are applied here. What unites companies and research is - they are innovative, professional, and hungry for knowledge. Laser technology made in Berlin and Brandenburg saves lives, every day.

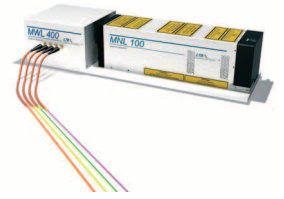

Multi-wavelength laser MWL400, providing pulsed laser light in up to 8 wavelengths simultaneously or successively

Source:
LTB Lasertechnik Berlin GmbH



Beam source for medical therapy

Source: Lumics GmbH

Diode laser module from the Ferdinand Braun Institute, which converts the wavelength via frequency conversion from infrared to the visible spectral range

Source: Ferdinand Braun Institute, Leibniz Institute for Highest Frequency Technology © FBH/schurian.com



Kai Kolwitz

6.6

Information and Communication Technology Glow in the Line: Laser Components for Communication from Berlin-Brandenburg

It could be sharper, brighter and lighter than conventional projectors: equipment projecting images via laser onto walls and screens. And the technology already exists. However, conventional laser projectors are too big, too heavy and too expensive to be an alternative to conventional technology for the living room and office.

Laser diodes or semiconductor constructions providing light in the three required color components red, green and blue might change that. Whoever makes the breakthrough has global market opportunities in many different applications.

The problem seems to be solved for the red component. The competition therefore focuses on supplying components providing green and blue light. Here, the region Berlin-Brandenburg is in the top group: at the Ferdinand Braun Institute, Leibniz Institute for Highest Frequency Technology (FBH), the sought after blue light has already been successfully created on the optical bench.

A trapezoidal DBR laser serves as the source and provides light with 976 nm wavelength. The wavelength is halved with the help of a crystal made of lithium niobate; laser light with 488 nm wavelength is created – not far from the 460 nm which are regarded as ideal. It is now of particular interest to miniaturize components, to make them reliable and to achieve enough output power to enable high-contrast, brilliant images.

Possibly, the sought after blue and green light can also be provided without frequency doubling. Great hopes are pinned on the material gallium nitride. The realization of highly efficient InGaN nanomaterials and thus the development of GaN-based laser diodes with high brilliance in the blue-green spectral range is part of a special research project at the TU Berlin. Involved in this research is again the FBH. However, fundamental work is still to be done here. First of all, it is necessary to find methods which can be used to produce usable crystal structures without too much effort.

Micro-projectors which could, for example, be installed in mobile phones and game consoles for mobile applications are nearing start of production. The

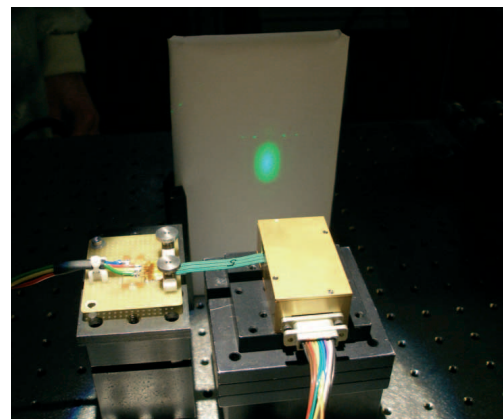

Green amplitude-modulated laser

Source: Fraunhofer Institute for Reliability and Micro Integration IZM

required output power levels are lower here – and Berlin also belongs to the world leaders in this sector: the prototype of a directly modulated green laser exists since two years at the company eagleyard Photonics. The FBH also stood at the beginning of this development. An infrared emitting laser diode is also used as a source, and its frequency is doubled by a crystal. Another research institution in Berlin, the Fraunhofer Institute for Reliability and Micro Integration (IZM), built the test module and is working on bonding techniques for lasers and crystals. The IZM is specialized in the miniaturization and packaging of such components.

Data Storage: Laser Light for New Memory Components

But, of course, data does not only have to be transferred, but also saved and reread. Since many years, the laser has played an important role here, exemplified by CD, DVD and BluRay drives. But the capacity of such media could still be increased, as the Optical Technologies work grouping at the Institute of Optics and Atomic Physics at the Technical University of Berlin is convinced, for example by using different colored lasers.

The goal of the TU's research is to develop a new generation of optical discs which can record a hundredfold of data content at the same size of a DVD. The principle: In micro holography, bits and bytes arise from tiny holograms written and read by highly focused laser beams. Unlike a DVD, the data containing photopolymer disk is transparent, and thus the depth of the storage medium is used as the third dimension to increase the capacity enormously. And a fourth dimension can also be added by using wavelength selectivity and writing overlapping HoloBits to the medium with different colored lasers.

The working group has already succeeded in demonstrating a storage capacity of about 500 gigabytes on a standard 12-centimeter disk. At the same time, a first drive was created in the laboratory, which is now, in close cooperation with American photopolymer disk manufacturers, developed to unfold the full potential of this technology in a compact disc & drive system. It is expected to reach up to 1000 GB storage capacity.

The Paul Drude Institute for Solid State Electronics also does research on new generations of non-volatile data storage, such as hard drives or flash disk, but faster and more powerful. The main focus is the laser and an alloy of germanium, antimony and tellurium, named $\text{Ge}_2\text{Sb}_2\text{Te}_5$ (GST). An interesting phenomenon is observed concerning this material: memory based on it is already being built in series, even though the principle is still not understood. What is known is that it possesses the properties of a semiconductor as well as a band gap in the infrared range. Irradiated by laser pulses GST can change

from the crystalline to the amorphous state and back, and from the atomic lattice structure to the disordered state and vice versa. Scientists at the Paul Drude Institute assume that memory elements, which are up to 1,000 times faster than flash memories in use today, could be realized based on this principle. They are now working on essentially understanding the material in order to fully exploit its potential.

Data Transmission at the Speed of Light

When it comes to high speed data transmission, there is no alternative to optics: lasers pump information into fiberglass networks, and optical detectors at the other end of the line are responsible for correctly registering zeros and ones for reassembling the output information. However, both the quantity of information transmitted globally as well as the demands on the transmission speed increase continually.

Therefore, there is always a need for faster lasers and detectors. In Berlin, a project funded by the Zukunftsfonds called 100x100 Optics (100 Mbit/s for 100 million users) is concerned with the development of these devices. The ultimate goal of the project is to develop technologies for data transfer with up to 100 Gbit/s, for example for the internet of the future. Involved are the Fraunhofer Institute for Telecommunications, Heinrich Hertz Institute (HHI), the component manufacturer uzt Photonics, and the Institute for Solid State Physics at the Technical University of Berlin.

In today's fiberglass networks, information is transmitted by intensity modulation of laser light. At very high modulation rates, fiber properties such as dispersion and nonlinear optical effects increasingly restrict the transmission of light pulses (bits) over long fiber lines that are common in telecommunication networks.

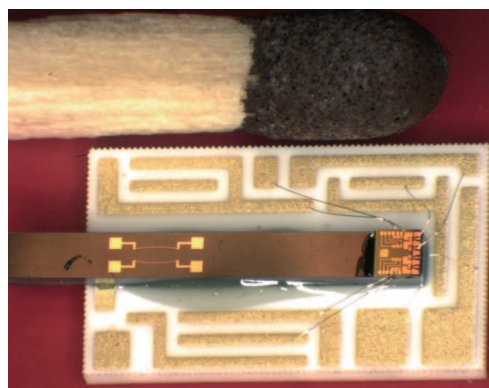

In recent years, optical modulation techniques not switching the intensity but rather the optical phase of the light wave were developed as a successful alternative. In the transmitter this so-called phase modulation is implemented via an electro-optic

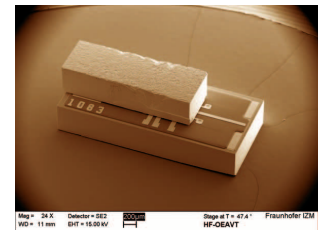

10 Gbit/s Ethernet transmission and receiver module

Source:

Fraunhofer Institute for Reliability and Micro Integration IZM

6.6

Optical receiver chip, polymer-based, with hybrid integrated four-fold photodiode array for the demodulation of phase information

Source:

Fraunhofer Institute for Telecommunications, Heinrich Hertz Institute (HHI)

Mach-Zehnder interferometer as a core component. The receiving end requires optical receivers which can demodulate the phase information. Such phase-sensitive optical receivers are developed in the project 100x100 Optics; they are based on integrated polymer waveguide chips.

In computer networks with typical transmission distances from meters to the lower kilometer range, fiberglass influences light transmission much less. For cost reasons, conventional intensity modulation continues to dominate here. However, today there are no transmitting lasers allowing a 100 Gbit/s direct modulation on the horizon. Therefore, a multiplex technique is used as a viable solution, in which the data streams are combined to a total bit rate of 100 Gbit/s by four lasers capable of 25 Gbit/s, each with slightly different wavelengths. In the project such 25 Gbit/s laser diodes are developed, whose light is switched by an integrated intensity modulator.

Enlargement of a VCSEL chip

Source:
TU Berlin – Institute for
Solid State Physics

of such laser diodes will increase beyond 30 Gbit/s. Other companies in Berlin-Brandenburg such as Advanced Laser Diode Systems (A.L.S.) have also recognized the enormous market potential of optical data

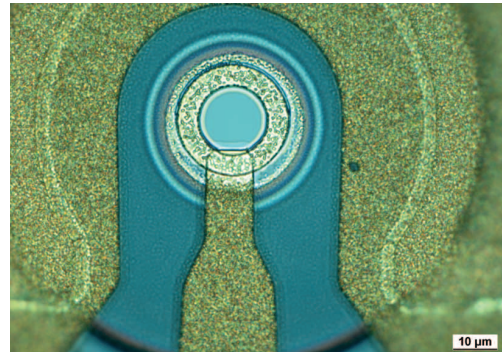

transmission. The company is a leading manufacturer of photo detectors and ultra-short pulse laser systems with pulse lengths down to the picosecond range. The repetition rates range from single shot up to 100 megahertz, and maximum power reaches the watt range. A.L.S. puts emphasis on turn-key systems. Modules such as the PiLas can be built according to customer specifications; different wavelengths are possible with just one module. Manufacturers such as Lumics or PBC (Photonic Band Crystal Lasers) also provide laser diodes and complete modules for communication applications. The Berlin company Polytec distributes devices including fiber lasers in the pico- and femtosecond range, optical amplifiers, and component test systems. As a strongly research-oriented company, uzt offers customer support even in the early stages of development. uzt components are usable for data transfer rates up to 640 gigabit per second via multiplexing; tunable laser diodes emitting pulses in the picosecond range serve as a signal source. For data transmission, visualization, and storage, laser technology is one of the keys to information and communication technologies of the 21st century.

6.6

Four-fold photodiode array, InP-based, with integrated bias-T for 4x25 Gbit/s

Source:
Fraunhofer Institute for
Telecommunications,
Heinrich Hertz Institute (HHI)

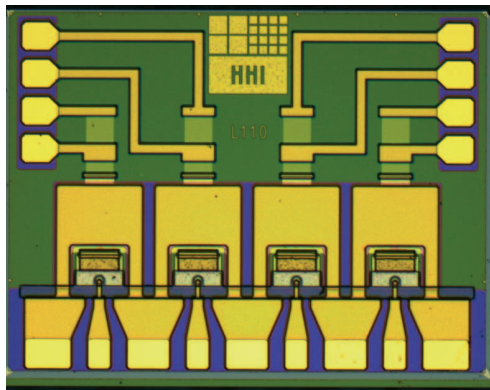

A third focus is surface-emitting laser diodes (VCSEL), which offer a number of specific advantages, including low power consumption and fast modulation. They are particularly interesting as transmitters for short optical connections. Thus, the bottleneck between the processor and external RAM of a computer and the high-rate connection of individual components on a board can be overcome (chip-to-chip optics). Using the latest materials technology, the speed

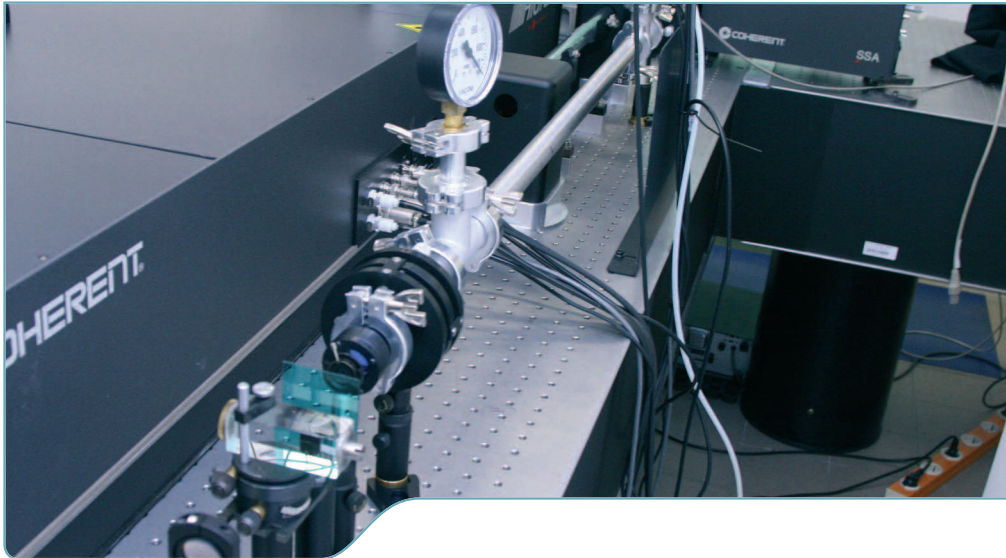

Test set-up for CRDS measurements

Source:
FU Berlin – Institute of Experimental Physics

Kai Kolwitz

Environment and Energy Search for Pollutants and Production of Solar Cells via Laser

6.7

Making weather via laser? At the Freie Universität Berlin (FU), this has been done for years; or more precisely, at the Institute of Experimental Physics at the FU, under Professor Ludger Wöste. Using powerful lasers, the Wöste working group succeeded in fetching lightning from the sky in a controlled manner. This scientific work can also be used for making rain. And it can help firefighters extinguish fires faster and more safely.

All applications are based on the same physical principle: ultra-short laser pulses are triggered. Their length lies in the femtosecond range, i.e. the millionth part of a billionth second. Due to the ultra-short pulse duration, the power increases up to the terawatt range. This in turn ensures nonlinear refraction of the air around the beam, which alternately focuses and defocuses the laser light and, as a result, keeps the beam stable over a long distance. Around the beam, a long plasma strand called the plasma filament is created. High power can thus be transferred over long distances.

A lot is possible with this principle. For example, Wöste and his staff succeeded in conducting lightning along the filament and thus keeping it away from airports and other sensitive places. Filaments can also be applied in the determination of the chance of precipitation. Along the beam, moisture in the air condenses to clearly visible water droplets. This indicates whether or not it makes sense to re-

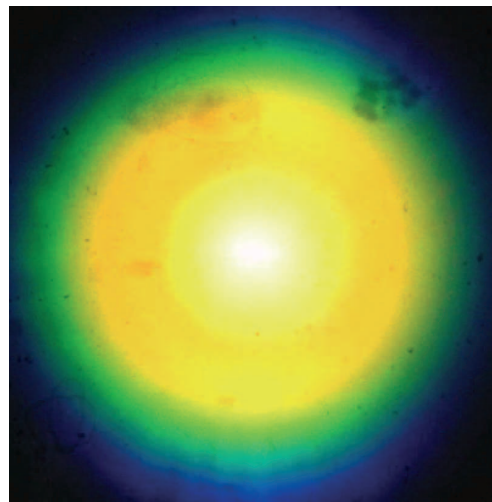

White light from a plasma filament

Source:
FU Berlin – Institute of Experimental Physics

lease rain via silver iodide in precipitation areas in a controlled manner.

Meanwhile, the Wöste working group concentrates mainly on the possibilities filaments offer in spectroscopy, specifically in cavity ring down spectroscopy. In this technique, the substance to be tested is placed between two partially transparent mirrors; it is identified by the decay time of a laser beam which is radiated into the system.

The Wöste working group discovered that laser filaments can be trimmed to provide a very coherent light which spans in a wide spectral range – the so-

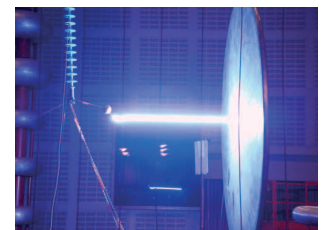

Controlled filament discharge

Source:
FU Berlin – Institute of Experimental Physics

Filaments in a quartz block

Source:
FU Berlin – Institute of
Experimental Physics

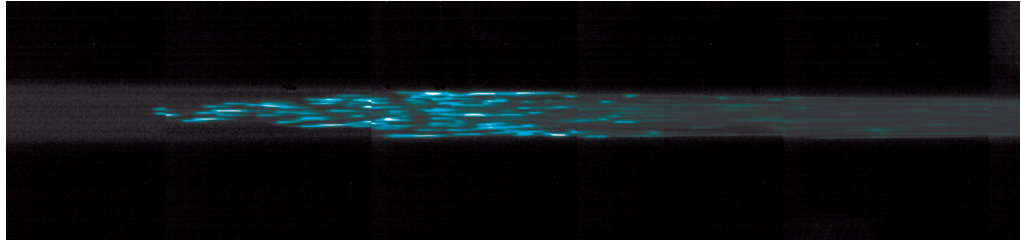

6.7

called super continuum. Thus, different wavelengths must not be spectroscopically handled sequentially, but can be studied simultaneously. So far, the spectrum of the super continuum ranges from 350 to 1100 nanometers in experiments. Due to the other properties of the filaments, studies are also possible over long distances.

This method is already patented, as well as the analysis of rain, and an earlier developed method for material analysis via laser and plasma filaments. Depending on which gases are contained in the air around the beam, for example as the result of a fire, the plasma lights up correspondingly. With a detector, such as a spectrometer, one can determine which substances are contained and if there is health or explosion risk. Due to the stability of the laser beam, even over longer distances, this can also be done from a larger distance. Thus firefighters do not have to put themselves in danger in order to obtain more accurate insights.

The work of the Wöste group is in line with the trend. In times of climate change and increasing awareness of air and water pollution techniques for environmental analysis are becoming increasingly important. And the laser beam can often assist in the analysis. Thus, Wöste's plasma filaments are not the only projects in which scientists from Berlin and Brandenburg try to detect environmental pollution and changes of the ecosystem via photonics.

The Institute of Optics and Atomic Physics at the Technical University (TU) is working on detectors for ocean water analysis via Raman spectroscopy, which is the analysis of inelastic scattering of laser light on molecules or solids. The research is conducted within the EU project SENSEnet. The objective is to develop long-term stable detectors which can measure substance concentrations in deeper marine areas – particularly changes in the oxygen content, because these indicate changes of the ecosystem.

Utilizing the Sun: Laser Applications in Photovoltaics

There is not only a wide range of applications for laser technology in analytics. The technology is also put to use when it comes to producing environmentally friendly energy. Especially solar energy is in the focus here – the region Berlin-Brandenburg is one of the German centers for the production of solar cells and modules.

On the one hand, manufacturers such as Solon, Sulfurcell, Inventux, PV Flex or Johanna Solar, on the other scientific and industrial expertise in the field of process engineering and laser material processing – the close networking of all market players is also coming to fruition in the solar sector. Among others, the Helmholtz Center for Materials and Energy is researching scientific and technological foundations for the application of thin-film technologies in silicon photovoltaics. The just two micrometers thick photoactive layers are generated by the crystallization of amorphous silicon via Xe-Cl excimer lasers. The Hahn-Meitner Institute, which was merged into the Helmholtz Institute, had already developed the world's first solar modules made of copper indium sulfide (CIS). They are now produced by the company Sulfurcell in Berlin, which was spun off from the Hahn-Meitner-Institut.

In order to strengthen the transfer between world class research and industry even further, the Helmholtz Institute has also launched the Competence Center Thin-Film- and Nanotechnology for Photovoltaics Berlin (PVcomB), together with the TU Berlin. The Center explores thin-film techniques with the materials silicon and copper indium gallium selenium. Industrial production processes and module sizes are considered even in early stages.

In order to put the competence on an even broader basis, PVcomB now also researches, together with further project partners, in the field of laser applications in photovoltaic production. Under the leadership of the industry association Photonik BB and Newport Spectra-Physics, with its headquarters in Stahnsdorf, Brandenburg, not only PVcomB but also the FH Brandenburg, the Fraunhofer Institute for Applied Polymer Research (IAP), and Laser- und Medizin-Technologie Berlin (LMTB) are concerned with issues relating to the industrial production of thin film cells and hence cooperate with project partners active in photovoltaic production. A key focus is on new laser micro-structuring techniques for patterning solar cells. An application laboratory for laser applications in photovoltaics in Stahnsdorf has been established by the project which is already used by several photovoltaic companies in Berlin and Brandenburg.

Lasers are long part of everyday life in manufacturing companies in the region, for example, when solar cells are patterned, cut, trimmed and marked, and

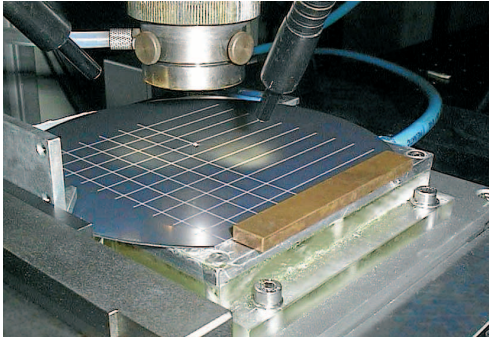

in quality controls. Procedures partly developed on site are applied. Thus LMTB did pioneering work in terms of processing of solar cells years ago by developing laser-based carving methods.

The LMTB process was the first to allow a clean separation of mono- and polycrystalline silicon wafers without a drop of the photovoltage of the cells or diminishing their efficiency. Meanwhile, LMTB also considers thin film cells as a central issue – the complex cell structure must not be perturbed by the treatment, which requires especially gentle procedures. Overall, techniques for production support in the solar sector are in the focus of almost all manufacturers of laser technology in Berlin and Brandenburg.

Natural Source: Laser Light From Sunrays

How about applying laser light not only for the utilization of solar energy but also using the sun's energy to produce laser light? The idea is as old as the laser principle itself. Today, a working group at the Institute of Optics at the TU Berlin is concerned with the solar laser: sunlight is focused with suitable optics so that it is able to directly pump a laser crystal. Energetically speaking, the technique is charming. No more energy has to be added during production of laser light other than sun rays. Thus, it is even far superior to the use of electricity from renewable sources. Why, for example, use solar cells to do lossy conversion of sunlight into electrical power which in turn provides the energy for a laser, when the light can also be used directly?

Such a solar-pumped laser already exists at the Technical University. It works with a Nd:YAG rod crystal and is placed into optimal position relative to the sun by the motor control unit. In addition, the working group has calculated the principle for an Egyptian region with high solar radiation. 170 watts of power are possible according to the calculation model. Likely, it would not be as much with German sunlight, but researchers believe the utilization of the principle could also be profitable in Berlin and Brandenburg.

Processing of silicon wafers with the short-pulse laser

Source:

Laser- und Medizin-Technologie GmbH, Berlin (LMTB)

6.7



Set-up of a directly solar-pumped solid state laser

Source:

TU Berlin – Institute of Optics and Atomic Physics

The five networks and transfer facilities in the German Capital Region



7.1

Industry Platforms Networks and Transfer Facilities

Optec-Berlin-Brandenburg (OpTecBB) – The Competence Network for Optical Technologies in Berlin-Brandenburg

More than ten years ago, a discussion supported by science and industry begun about which specific sub-disciplines of optical technologies to develop in Germany in order to become or remain internationally competitive and to develop them as driving forces for innovation.

This action program was documented as the "German Agenda on Optical Technologies for the 21st Century" and led to the BMBF (Federal Ministry of Education and Research) program "Optical Technologies Made in Germany". One of its immediate impacts was the formation of competence networks for optical technologies, which are part of this support program and form one of the infrastructural elements accompanying its implementation. Another is OptecNet Germany, which has all networks as its members and organizes a constructive cooperation among the networks in Germany.

OpTecBB is part of this strategic process and was founded as an association on September 9, 2000 by 14 companies, research institutions, universities and associations with the support of the responsible state Ministries of Brandenburg and the Berlin Senate.

OpTecBB and its members have set the following goals and objectives:

- combine and network the existing potential in the region in the field of optical technologies
- support the knowledge and technology transfer from research to the companies
- initiate R & D projects and support cooperations
- form a platform for information and communication
- organize joint marketing activities and trade fair appearances in order to promote the companies, research institutions and the region
- inform and advise the state governments and organizations providing support to businesses
- support education and training in the field of optics/photonics and promote the region as a training site

With the adoption of the focus area management, the coordination of joint activities in Berlin and Brandenburg and the establishment of the industry transfer unit Optics of the State Brandenburg, OpTecBB takes on the function of an umbrella organization in this technology field.

Contact:

Dr. Bernd Weidner

OpTecBB e.V.

Telephone: +49 - 30 - 6392 1720

Email: optecbb@optecbb.de

Internet: www.optecbb.de

Laserverbund Berlin-Brandenburg e.V.

The Laserverbund Berlin-Brandenburg e.V. is a group of laser experts from industry and science. The association was founded in December 1993 in Berlin and now has 100 members.

The objective of the association is to support the utilization of laser technology, primarily in Berlin and Brandenburg. It supports the cooperation among companies and research institutions in the fields of laser research, development and application.

The Laserverbund offers seminars, workshops and training on topics related to laser technology and gives information on current issues in the industry in the "LASERBRIEF", at the "laser regulars' table" and on its website.

Contact:

Dr. Helmut Ringelhan

Laserverbund Berlin-Brandenburg e. V.

Email: H.Ringelhan@PhotonAG.com

Internet: www.Laserverbund.de

c/o

Photon Laser Engineering GmbH

Telephone: +49 - 30 - 364 088 22

PhotonikBB e.V.

PhotonikBB regards itself as a professional networking and coordination platform for industry and research in the focus area optics with an emphasis on the state of Brandenburg. The network initiates, coordinates and supports the collection of skills in joint projects.

Particular emphasis is placed on bringing creative small and medium-sized businesses together with science in order to form top clusters with high competence and strong industrial connections. This pooling of skills and the coordinated cooperation of industry, universities and institutions is expected to lead to regional added value and tap the existing potential.

The following areas of innovation are emphasized in the network's activity:

- applications in photovoltaics
- applied laser technology
- measurement and sensors technology
- photonic components

Contact:

Andreas Feldo

PhotonikBB e.V.

Telephone: +49 - 3328 - 430 230

Email: info@photonik-bb.de

Internet: www.photonik-bb.de

TSB Group

The TSB Group is a central contact point for technology and innovation in Berlin; it has developed the coherent innovation strategy together with the major

players in the city. Its objective is to support the focus areas in the Capital Region, which have been influenced by a variety of innovative enterprises and scientific research institutions, in their development of internationally competitive and sustainably growing high-technology clusters.

The credo is: strengthen strengths and support areas of technology which are characterized by strong growth and in which Berlin already has a high relative market share. This includes biotechnology, medical technology, transport & mobility, information and communication technology, and optical technologies and microsystems technology.

The strategic work of the TSB Technology Foundation Berlin is augmented by the operational business of the TSB Innovation Agency Berlin.

Due to the strong concentration of research institutions and companies in Berlin, the TSB has a clear focus on optical technologies and the closely related field of microsystems technology. The TSB networks the local companies with research institutions, develops and presents innovative research and development projects and gives advice on technology transfer. Single modules are the active participation in committees and associations, such as OpTecBB e.V., PhotonikBB e.V. or the Laserverbund Berlin-Brandenburg e.V., the organization of events and the development and publication of an industry report.

Contact:

Prof. Dr. Eberhard Stens

TSB Innovationsagentur Berlin GmbH

Telephone: +49 - 30 - 46 302 440

Email: adlershof@tsb-berlin.de

Internet: www.tsb-adlershof.de

ZukunftsAgentur Brandenburg (ZAB)

The ZukunftsAgentur Brandenburg GmbH (ZAB) is the central contact point for business development in Brandenburg. It emphasizes business settlements, the development of an innovative middle class including export business support, the support of technology-oriented start-ups and energy consulting.

The ZAB has a partnership with the Brandenburg State Investment Bank (ILB) and the Brandenburg Capital GmbH.

The Enterprise Europe Network at the ZAB provides advice specifically for European framework programs and initiates international cooperations.

Contact:

Michael Koinzer

ZukunftsAgentur Brandenburg GmbH

Telephone: +49 - 331 - 660 30 00

Email: info@zab-brandenburg.de

Internet: www.zab-brandenburg.de

www.invest-in-brandenburg.com



Laser Optics Berlin 2010
Source: Messe Berlin GmbH

7.2

Industry Platforms
Laser Optics Berlin



Following German reunification, when many small and medium-sized companies were founded in the field of optical technologies, particularly in the science and technology park Berlin-Adlershof, the call for a regional presentation and discussion platform

became louder. In the mid-90s, scientists and engineers first met at the "Optical Day(s)" in Adlershof. The purpose of the event was to discuss scientific insights, find potential applications and explore trends. In 1996, the event took place for the first time

Number of exhibitors at Laser Optics Berlin

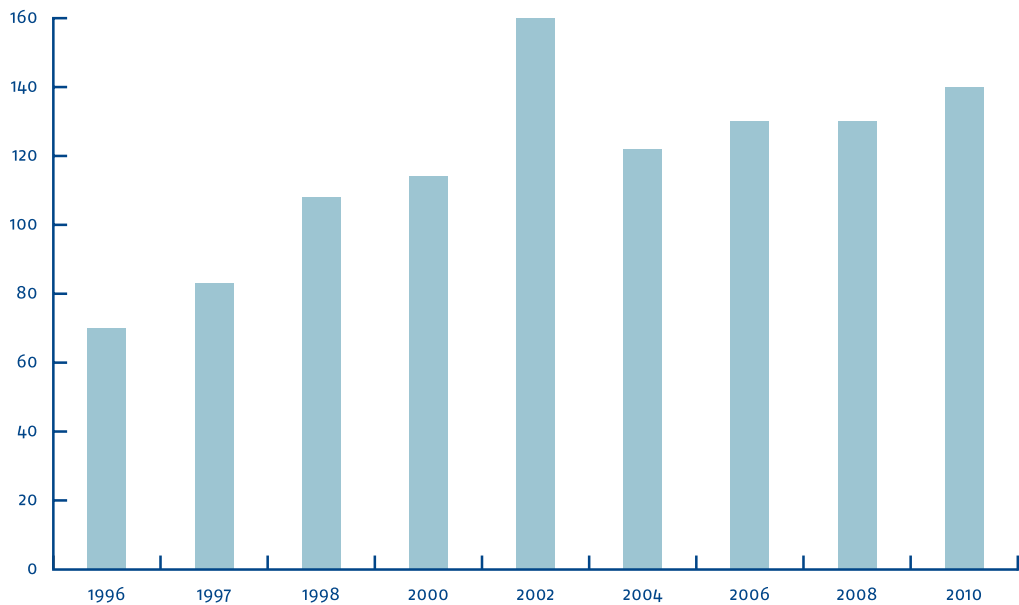

Source: TSB Innovationsagentur Berlin GmbH

Year

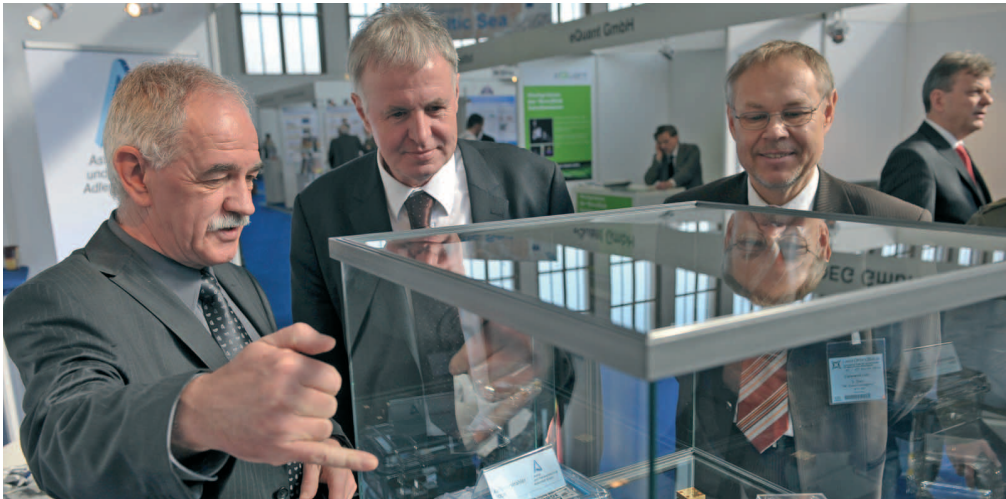

Laser Optics Berlin 2010
Source: Messe Berlin GmbH

as Laser+Optics Berlin (LOB) and was held in a very informal environment.

After 2000, the LOB was held at the science and technology park Berlin-Adlershof three more times every two years before outgrowing its infancy. The steadily growing number of exhibitors and qualified visitors made the LOB interesting for the Messe Berlin GmbH and, in 2008, it moved to the fairgrounds under the radio tower, where it received the name "Laser Optics Berlin". In 2010, the fair took place with 140 exhibitors and an increasingly international audience.

Initially, the focus was only on laser technology, optoelectronics and optics, but today all areas of optical technologies are represented. New technology fields, such as most recently terahertz technology, are quickly entering the scientific congress and the program of the Laser Optics Berlin.

The principle performers of the past are still deeply connected with the Laser Optics Berlin today. Prof. Dr. Thomas Elsässer, director of the Max Born Institute (MBI) was then as now leading in the scientific congress. Prof. Dr. Eberhard Stens was the project manager of the Laser Optics Berlin at the TSB Innovationsagentur Berlin GmbH from 1998 to 2006. Today, the TSB functions as a non-material co-sponsor of the event. Dr. Matthias Scholz from the LTB Lasertechnik Berlin GmbH in Adlershof managed the exhibitor advisory board for many years. The WISTA Management GmbH, site operator of the science and technology park Berlin-Adlershof, the networks OpTecBB and the Laserverbund Berlin-Brandenburg also actively support the event.



Today, the Laser Optics Berlin is one of the leading congresses for optical technologies in Europe and is steadily expanding its spectrum. In 2010, microsystems technology, closely linked with optical technologies, received its own workshop in the program of the Laser Optics Berlin. The interest abroad is constantly increasing: in 2010, the leading cluster and network managers from Scandinavia, the Baltic States, Russia and Poland, accompanied by nearly 20 companies and research institutions, gathered at the



7.2

Laser Optics Berlin 2010
Source: Messe Berlin GmbH

Laser Optics Berlin to present themselves at the exhibition and a cluster colloquium and to explore the potential for strategic cooperations.

As the industry of optical technologies itself, the Laser Optics Berlin distinguishes itself by an above-average, sustainable growth and will remain an appealing meeting place, not only for companies and research institutes in Berlin-Brandenburg.

Contact:

Kerstin Kube-Erkens
Messe Berlin GmbH
Telephone: +49 - 30 - 3038 2056
Email: kubeerkens@messe-berlin.de
www.laser-optics-berlin.de

Prof. Dr. Eberhard Stens
TSB Innovationsagentur Berlin GmbH
Telephone: +49 - 30 - 46302 440
Email: stens@tsb-berlin.de
www.tsb-adlershof.de

Laser Optics Berlin 2010
Source: Messe Berlin GmbH

References

- Albrecht, E. (2005): 20 Jahre Laser- und Medizin-Technologie Berlin. Press release of the LMTB GmbH. In: Informationsdienst Wissenschaft <http://idw-online.de/pages/de/news114560> (June 1, 2005)
- Albrecht, H. (1997): Laserforschung in Deutschland 1960–1970. Eine vergleichende Studie zur Frühgeschichte von Laserforschung und Lasertechnik in der Bundesrepublik Deutschland und der Deutschen Demokratischen Republik. Habilitation, Stuttgart: University of Stuttgart.
- Albrecht, H. (2001): Die Innovation des Lasers in Deutschland – Forschung an der TU Berlin und der Universität Jena im Vergleich. In: Abele, J./Barkleit, G./Hänseroth, T. (ed.): Innovationskulturen und Fortschrittserwartungen im geteilten Deutschland. Cologne etc.: Böhlau, 263–276.
- Gönner, H. (2005): Einstein in Berlin 1914–1933. Munich: C.H. Beck.
- Kopfermann, H. (1952): Rudolf Ladenburg. In: Die Naturwissenschaften, 39 (13), 25.
- Lenz, K. (1995): Der Laser. In: Frieß, P./Steiner, P.M. (ed.) Deutsches Museum Bonn: Forschung und Technik in Deutschland nach 1945, Catalog. Munich: Deutscher Kunstverlag, 368.
- Lerch, F. (2009): Netzwerkdynamiken im Cluster: Optische Technologien in der Region Berlin–Brandenburg. Dissertationen Online at the Freie Universität Berlin. http://www.diss.fu-berlin.de/diss/receive/FUDISS_thesis_000000013342
- Minkowski, R. (1929): Theorie der Brechung. In: Müller-Pouillet (ed.): Lehrbuch der Physik. Braunschweig, Vieweg, Vol. 2, 1708.
- Niedrig, H. (1987): Nachruf auf den Pionier der Elektronenmikroskopie: Hans Boersch 1909–1986. In: Optik 75, 172–174.
- TSB Innovationsagentur Berlin GmbH (2008a): Report 2008/2009 – Optische Technologien und Mikrosystemtechnik Berlin–Brandenburg, Berlin
- TSB Innovationsagentur Berlin GmbH (2008b): Report 2008 – Verkehr und Mobilität in Berlin–Brandenburg, Berlin
- TSB Technologiestiftung Berlin (2008c): Studien zu Technologie und Innovation – Das Technologiefeld Energie in Berlin–Brandenburg, Berlin
- Wissenschaftsrat (1992): Stellungnahmen zu den außeruniversitären Forschungseinrichtungen der ehemaligen Akademie der Wissenschaften der DDR auf dem Gebiet der Physik. Cologne: Wissenschaftsrat.

For more information on optical technologies and microsystems technology in Berlin please see our industry report or visit our website:

www.tsb-adlershof.de



8.0

Report optical technologies and microsystems technology in Berlin-Brandenburg

Imprint

Report 2010
 Laser Technology
 Berlin-Brandenburg

Editor

Editor of this study is the TSB Innovationsagentur Berlin GmbH

Prof. Dr. Eberhard Stens
 TSB Innovationsagentur Berlin GmbH
 Fasanenstr. 85
 D-10623 Berlin

The copyright of all texts and graphics in this report is owned by the authors, who are represented by the editor. All copyrights remain reserved. Any form of reproduction, e.g. typographical, electronic, optical, photomechanical or similar – even in extracts – requires the express written permission from both the publisher and the author of the text and graphics.

Contents

The editor does not assume liability for the contents of the editorial contributions.

This book edition represents a temporary state of a continuous work in process. Although we were very careful while collecting the information, the TSB Innovationsagentur Berlin GmbH cannot vouch for its accuracy, correctness or completeness.

In no event shall the TSB Innovationsagentur Berlin GmbH be liable for any damages whatsoever arising out of or in connection with the use of the information provided herein, no matter if direct, indirect or consequential damages, including lost profits.

The TSB Innovationsagentur Berlin GmbH would like to thank all participants for their assistance in this industry report, including the provision of comprehensive high quality digital pictorial material. The selection of the companies and research institutions portrayed is exemplary of the region and does not claim to be complete.

Errors and omissions excepted.

Chief Editors:

Prof. Dr. Eberhard Stens, Gerrit Rössler

Project Assistant:

Florian Oswald

Authors:

Kai Kolwitz, Journalist
 Dr. Frank Lerch, N R C Network Research & Consulting UG, c/o Freie Universität Berlin
 Markus Wabersky, m.wabersky projektberatung
 Gerrit Rössler, TSB Innovationsagentur Berlin GmbH
 Prof. Dr. Eberhard Stens, TSB Innovationsagentur Berlin GmbH

Translation:

Dr. Otto-G. Richter
 Richter IT&S Consulting, www.richter-its-consulting.de

Layout + Graphics:

Heike Rusch, Markus Wabersky, www.mixxd.com

Printing Company:

Das Druckteam Berlin Maik Roller und Andreas Jordan GbR, www.druckteam-berlin.de

9.0





Save the Date

19–21 March 2012



LASER OPTICS BERLIN

International Trade Fair and Convention
for Optical & Laser Technologies

www.laser-optics-berlin.com

TSB 



OpTecBB



Berlin Adlershof
WISSEN TRIFFT KONNEN SEIT 1909



TSB Innovationsagentur Berlin GmbH

Fasanenstraße 85
D-10623 Berlin
Telephone: +49 - 30 - 46302 440
Email: adlershof@tsb-berlin.de
www.tsb-adlershof.de