

COMPACT 10/12 DX

Rough-terrain scissor lifts

The Haulotte® advantages

- Hydraulic differential lock for improved rough terrain traction
- Full proportional controls
- Robust, reliable and easy to maintain design
- Tight turning radius provides excellent manoeuvrability

STANDARD FEATURES

- Deutz engine
- 4 wheel drive with 2 front steer wheels
- 3° Tilt alarm
- 1,2m (47 in) platform extension
- 12V - 70 Ah Batteries
- Removable operator's control box
- Free wheeling device
- Hourmeter
- Towing hooks / lifting eyes
- Hydraulic brakes
- Manual emergency lowering control at ground level
- Foam filled all terrain tyres
- Side protection
- Horn
- Safety harness anchor points

OPTIONS & ACCESSORIES

- Rotating beacon
- Power line in cage
- Fold down handrails
- Automatic levelling outriggers
- Work light
- Catalytic exhaust
- Biodegradable oil
- Motion alarm for movements and translation
- Non-marking tyres
- Individual levelling outriggers
- Warming kit for engine oil

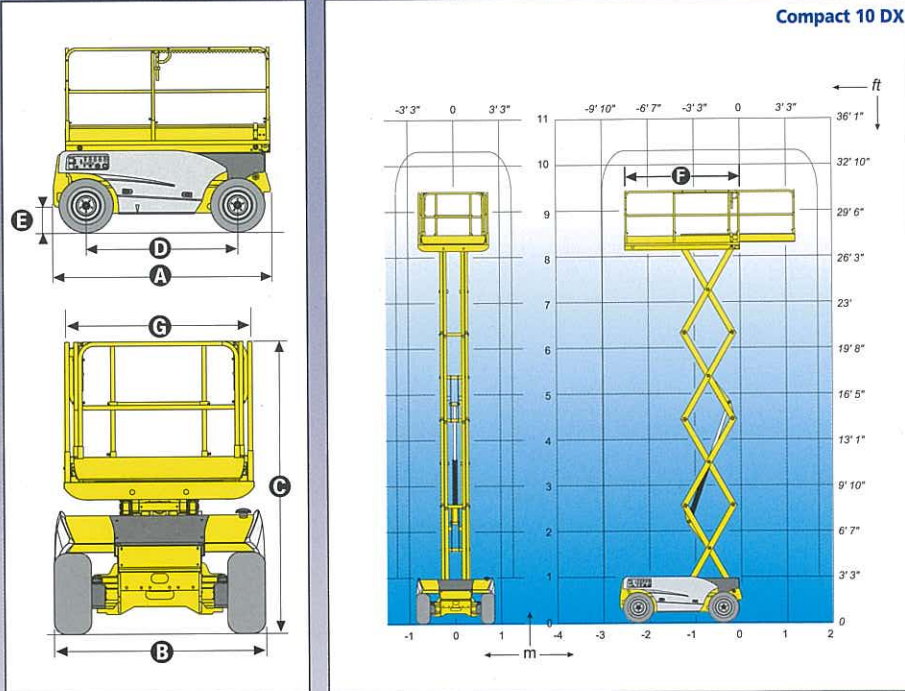

SPECIFICATIONS

	Compact 10DX		Compact 12DX	
Working height	10,2 m	33 ft 5 in	12,15 m	40 ft
Platform height	8,2 m	27 ft	10,15 m	33 ft 3 in
Platform capacity	565 kg	1,245 lb	450 kg	992 lb
A Length	2,65 m - 8 ft 8 in			
B Width	1,80 m - 6 ft			
C Stowed height (guardrail)	2,37 m	7 ft 10 in	2,54 m	8 ft 4 in
Stowed height (platform)	1,5 m	4 ft 11 in	1,68 m	5 ft 6 in
D Wheelbase	1,87 m - 6 ft 1 in			
E Ground clearance	25 cm - 10 in			
F x G Platform size	2,5 x 1,54 m - 8 ft 2 in x 5 ft 1 in			
Platform extension	1,2 m - 47 in			
Drive speed	0,8 / 5,5 km/h - 0,5 / 3,4 mph			
Outside turning radius	3,73 m - 12 ft 3 in			
Inside turning radius	1,45 m - 4 ft			
Lift / lower speed (s)	31/27 sec.		45/39 sec.	
Power source	Deutz 18kW - 24.5 hp			
Gradeability	40%			
Brakes	Hydraulic			
Tyres (foam filled)	26 X12-16.5			
Hydraulic tank	80 l - 20 gal			
Fuel tank	30 l - 8 gal			
Weight	3 330 kg	7300 lb	3 830 kg	8580 lb

AS1418.10



HAULOTTE UK LTD • TEL : +44 (0)1952 292753 • www.haulotte-international.com
 HAULOTTE SCANDINAVIA AB • TEL : +46 31 744 32 90 • www.haulotte.se
 HAULOTTE AUSTRALIA PTY LTD • TEL : +61 (0)3 9706 6787 • www.haulotte.com.au
 HAULOTTE SINGAPORE PTE LTD. • TEL : +65 6546 6150 • www.haulotte.sg
 HAULOTTE POLSKA SP. Z.O.O. • TEL : +48 22 885 65 17 • www.haulotte.com.pl

HAULOTTE TRADING (SHANGHAI) CO. LTD. • TEL : +86 21 6288 8228 • www.haulotte.cn
 HAULOTTE NEW ZEALAND • TEL : +64 (0)9 277 6612 • www.haulotte.com.au
 HAULOTTE MIDDLE EAST FZE • TEL : +971 (0)4 299 77 35 • www.haulotte-international.com
 HAULOTTE VOSTOK, OOO • TEL : +7 495 730 0580, +7 962 924 69 80 • www.haulotte-international.com

Haulotte
GROUP