

USER MANUAL

PARKIS (Exclusive / Stainless Steel / Basic)



PARKIS

CE

All rights reserved

Dear User,

Congratulations on purchasing your PARKIS!

PARKIS is a household equipment for vertical bicycle parking which lets you free up precious storage space on the floor. Should you need more information on PARKIS purpose, usage and installing, please visit us at www.parkis.eu. If you have any questions, we'll have answers!

Important

These instructions accompanying the product are original instructions.

It is important that you read the entire USER MANUAL to familiarise with this product before use. Persons not acquainted with the information provided in this manual are not allowed to use the equipment. Adult supervision is highly recommended for junior users of the PARKIS. We do not take any responsibility and we are not liable for any damage caused through use of PARKIS in case you fail to strictly follow the instructions provided in this manual. Warranty will not be applied if the damage is caused by your failure to follow the instructions. Having read the manual carefully, please keep it for future reference or subsequent holder of the product as this manual is part of a product.

Whilst every effort has been made to ensure the accuracy of the information contained in this manual, the PARKIS policy of continuous improvement determines the right to make modifications without prior warning.

Introduction

This USER MANUAL applies for PARKIS Exclusive, Stainless Steel, Basic. Further in the text - PARKIS. All USER MANUALS are updated continually, user should make sure that they use the very latest version. Downloads are available here: www.parkis.eu

UAB PARKIS
Piliakalnio str. 7
Vilnius
Lithuania
LT-06229

WEBSITE: www.parkis.eu
SUPPORT: parkis@parkis.eu



EC DECLARATION OF CONFORMITY

The undersigned Company hereby declares that the equipment described below:

Type of machine: **Bicycle Parking Lift**

Model: **Parkis**

Serial number(s): -

complies with the provisions of the “**Machinery directive 2006/42/EC**” (Directive 89/392/EEC, as amended) and the regulations transposed it into the national law.

Harmonized standards applied:

ISO 12100:2010 “General principles for design. Risk assessment and risk reduction”.

Other technical standards and specifications used: -

Content

1. Intended use
2. Set
3. Key elements
4. Assembly instructions
5. Use (operation)
6. Maintenance
7. Deactivation
8. Safety
9. Dismantling
10. Warranty

1. Intended use

1.1 This “Bicycle Parking Lift PARKIS” (further PARKIS) is a mechanical equipment designed for a vertical parking of your bicycle.

1.2 PARKIS (Exclusive / Stainless Steel / Basic) fits the most popular bicycle models. Only these criteria apply*:

*tire width max. 61mm (2,4”) (fig. 1.A).

*rim + tire total height max. 77 mm (3.0”) (fig. 1.B).

*wheel diameter min. 61 cm (24”)

*weight on front bicycle axis up to 15 kg (33 lb) (fig. 1.E).

*mud flaps ends must be above the wheel axis (fig. 1.C, 1.D).

Suitability can be checked by leaning the bike’s rear wheel against the wall. If the wheel (not a mudguard) touches the wall – Parkis is suitable for your bike’s mud flaps. (fig. 1.)

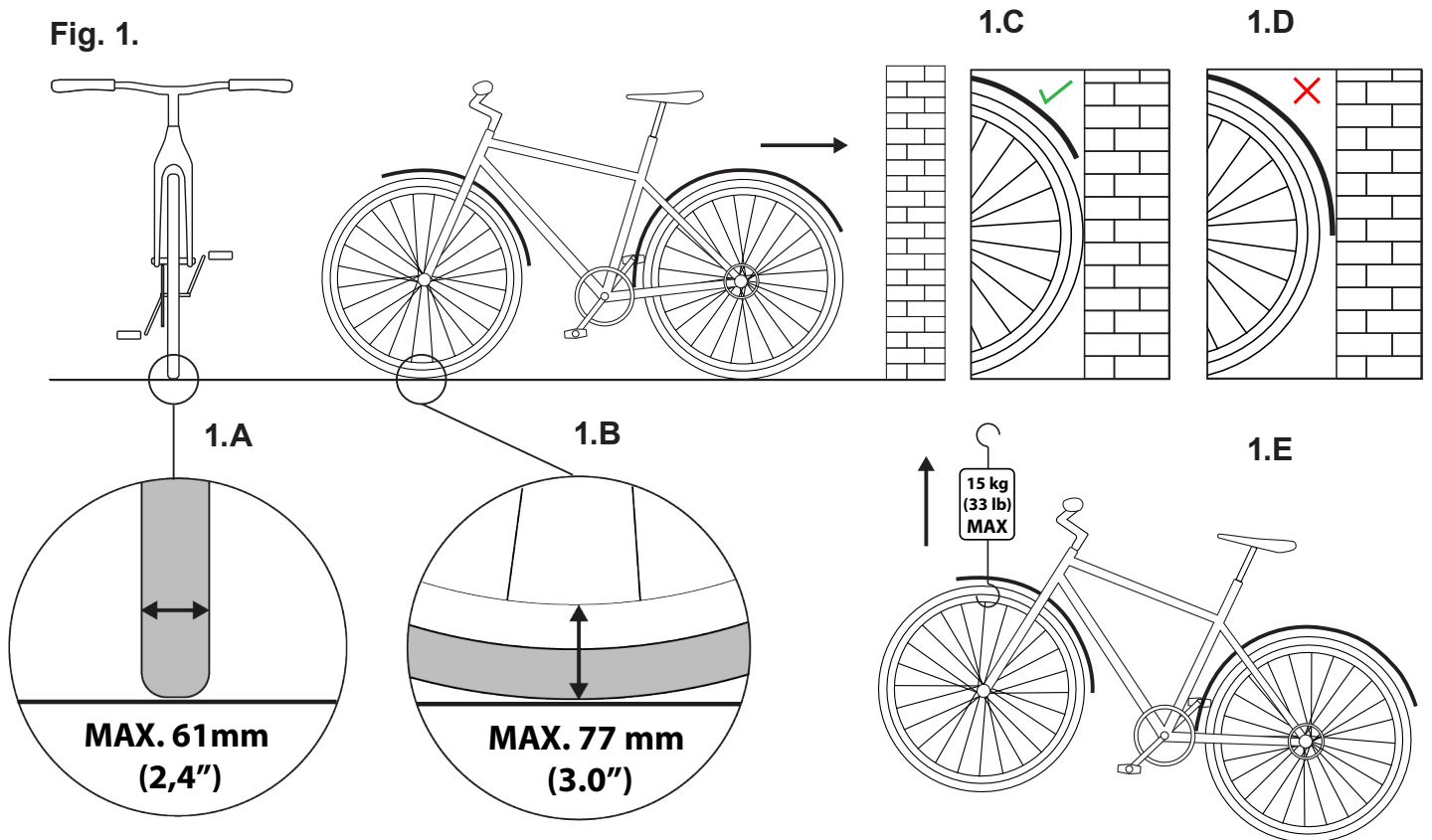

IMPORTANT! Before parking your bicycle make sure it meets these criteria.

PARKIS reference dimensions: 170 x 25 x 16 cm (67 x 10 x 6 in), reference weight 6 kg (13,2 lb).

1.3 PARKIS (Basic / Stainless Steel / Exclusive) is designed for an individual use in spaces that are protected from precipitation.

2. Set

Set includes:

1. Parking lift PARKIS
2. 4 screws for masonry wall installation
3. User manual

3. Key elements

1. Stand
2. Wheel locking mechanism (dolly)
3. Screws (set includes masonry screws)
4. Safety-catch for transportation only.
Having fastened the equipment to the wall, safety-catch is removed

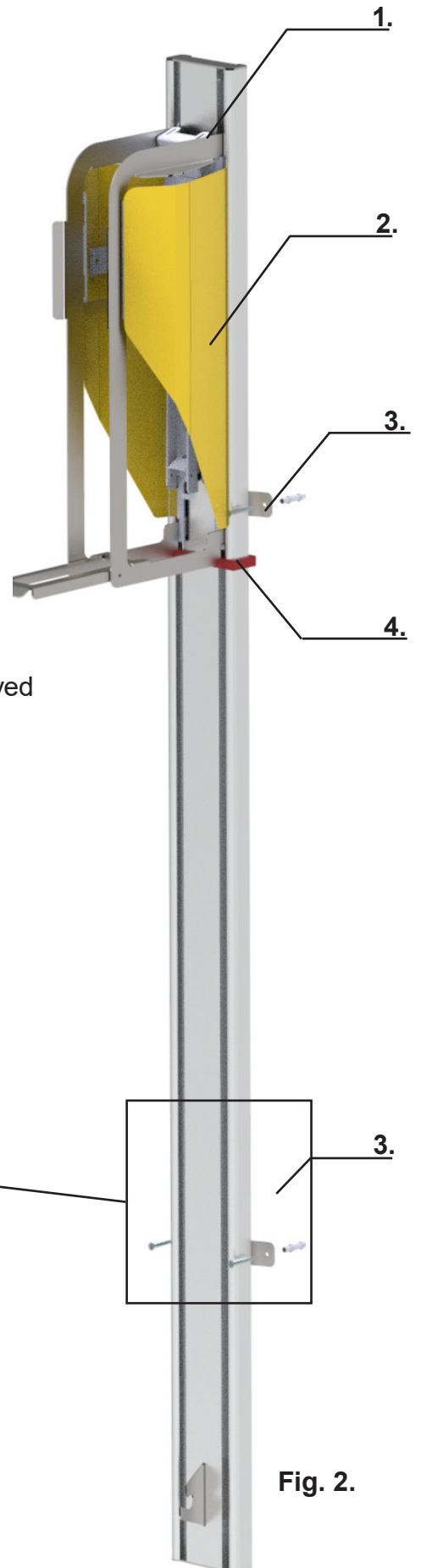

Fig. 2.

4. Assembly instructions

4.1 To install PARKIS, wall and floor surface must be even and level. Place the parking equipment on the floor, lean it to the wall and mark the spots for screws to be fastened. If you intend to mount PARKIS to the masonry wall (which is recommended), make pilot holes for fastening screws, install screw anchors, lean the equipment along the wall accurately and screw the equipment to the wall tightly. For other types of wall please obtain suitable screws.

4.2 Remove safety-catch (fig. 3.A).

4.3 Put a wheel's support to the horizontal position (fig. 3.B).

4.4 Push a wheel locking mechanism (in further text – dolly) to the ground position limit. You will normally feel resistance while pushing. It will fix automatically on floor level (fig. 3.C), now your PARKIS is ready to use!

Fig. 3.

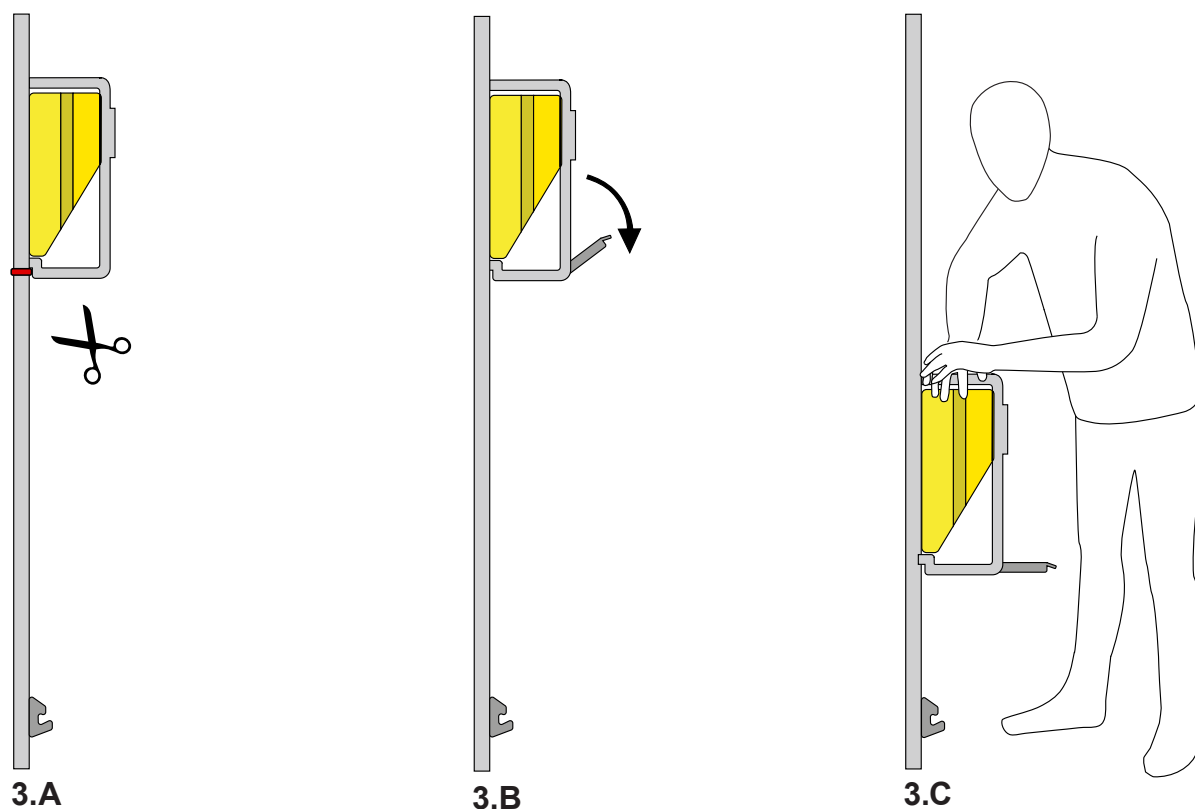

5. Use - parking

1. Before parking your bicycle make sure that there are no children or pets around to avoid accidents. Hold your bicycle so that both wheels have to be on the line perpendicularly to the surface that PARKIS is fastened to.
2. Use one hand to lightly hold a handle bar of your bicycle (first time users are advised to pick the bar underhand) and firmly take the saddle with the other hand. We recommend you to hold the saddle with your leading hand. (fig. 4.A)
3. Firmly push the saddle forward while the handlebar lightly lifting up and directing the front wheel towards the wheel locking mechanism until the wheel locks. Attention! Do not push the handle bar downwards! Let the front wheel go up freely (fig. 4.B and 4.C). At the same time hold firmly the saddle and direct a rear wheel so that it goes in the middle of the stand. Your bike has been parked! (fig. 4.D)

Note

If the wheel has not been locked from the first time and the dolly moved upwards, just put your bicycle aside safely, use a hand to push the dolly down until fixed position (fig. 3.C) and repeat the parking process once again. Some practice is necessary to get used to parking your bicycle this way. While parked your bicycle has to be protected from accidental impact (eg. turning or bending) as this can damage the equipment, your bicycle or harm a person.

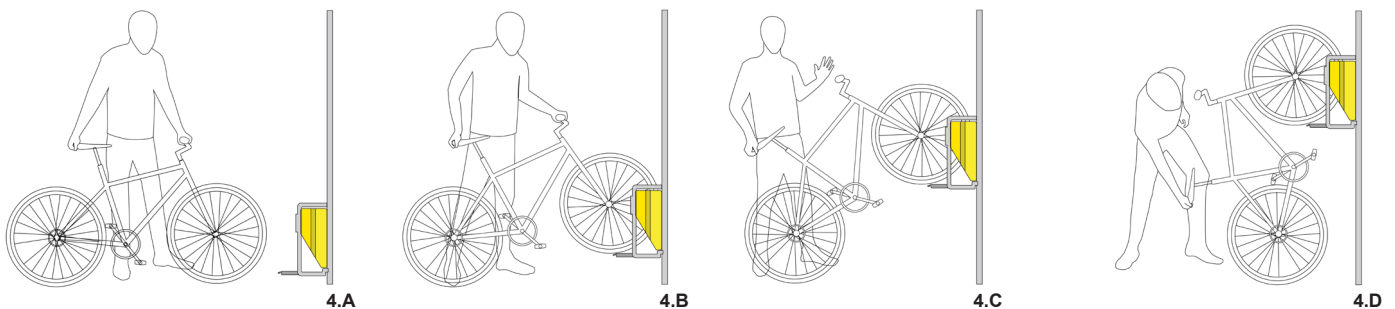

5. Use - removing a bicycle

Use a hand to hold the saddle (not the handlebar!) and firmly pull towards yourself (fig.5.A). As the bicycle starts descending push a handlebar down with your other hand (fig. 5.B & 5.C) until the front wheel reaches the ground and is removed from the wheel locking mechanism (fig. 5.D). Your bicycle is removed from the parking equipment!

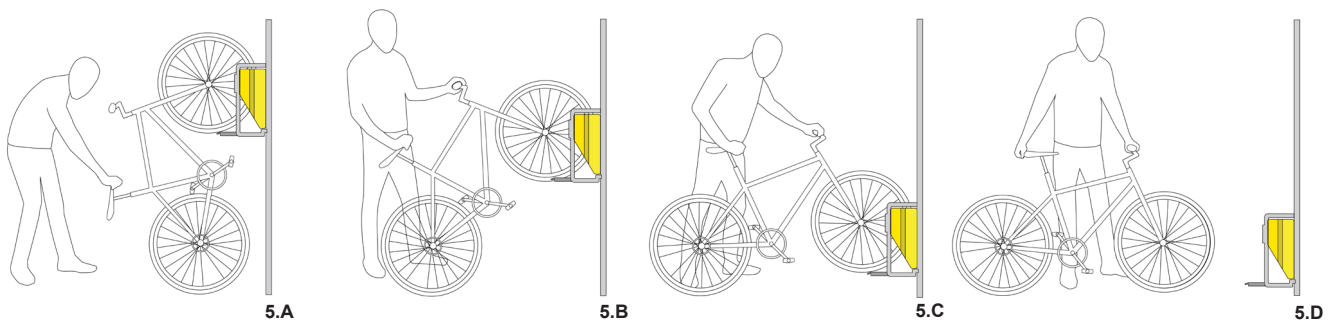

6. Maintenance

PARKIS' construction allows to use it for a long time without any particular maintenance. Consider these tips to enjoy PARKIS even more:

1. Get your bike clean before you park it in PARKIS.
2. Do not use materials containing solvents or diluents to clean PARKIS.

If you intend not to use PARKIS for a longer period of time (month or more), we recommend keeping a dolly in the upper position on the stand (deactivated) – how it is positioned when a bicycle is parked or the equipment is not activated (see par. No. 7). It increases durability of the spring inside the stand.

7. Deactivation

Perform deactivation prior to dismantling, maintenance, cleaning or leaving PARKIS without parked bicycle for a longer period of time (month or more).

A screwdriver is required for deactivation process

We strongly recommend you to call someone for assistance to hold bicycle in place to ease deactivation process

1. While bicycle is parked in vertical position, hold your bicycle firmly in the middle of handlebar (on stem) and apply light pressure towards PARKIS (fig. 6.A).

2. Place the screwdriver between flat metal part and pin (fig. 6.B).

3. Lever the screwdriver down, (fig. 6.C), until mechanism releases the bicycle wheel. **Please note that bicycle will fall out if not held firmly and may cause damage or harm.**

4. Remove the bicycle and put up PARKIS wheel support. You have now performed PARKIS deactivation.

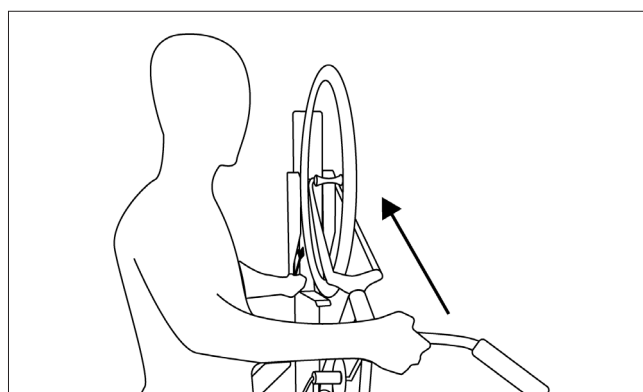

6. A

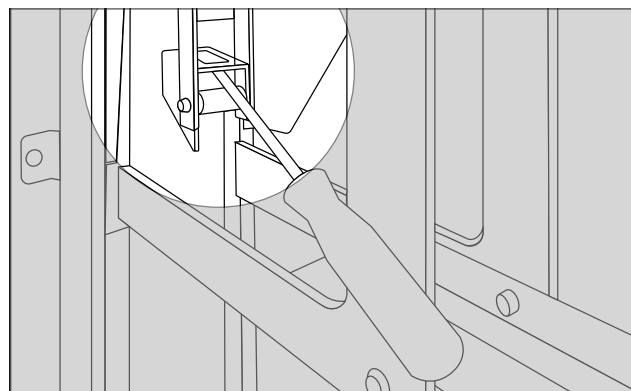

6. B

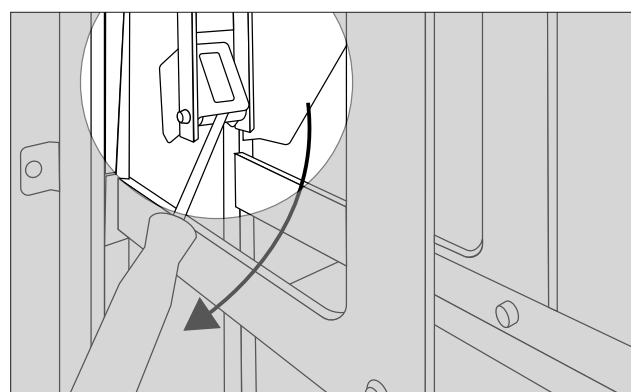

6. C

8. Safety

When unpacking, make sure that the item is intact and undamaged. If any parts are broken, please contact your seller.

Use PARKIS to park only technically accurate bicycles with fully inflated tires and only those that meet the above listed specifications (see par. no. 1.2).

Having parked your make sure that the front wheel is properly locked and the rear wheel rests centered to the PARKIS stand.

Do not use bicycle lift if stand surface got damp due to humidity condensation, precipitation or other reason.

ATTENTION! When the dolly is fixed in lower position (activated), it possesses potentially dangerous energy (springs inside the stand are stretched!!!).

When the equipment is in use or dolly is in lowered position (activated):

DO NOT place hands inside the dolly!

DO NOT place fingers inside any part of the equipment!

DO NOT try to dismantle or repair the bicycle lift!

DO NOT allow children to play near the bicycle lift!

DO NOT allow pets to be around the device!

9. Dismantling

1. Deactivate the parking equipment (see par. No. 7)

2. Remove screws that hold the equipment in place (it's recommended to start with the lower ones).

10. Warranty

This warranty covers all manufacturing and material defects for a period of 12 months from the day of product purchase. In case of a warranty claim please provide seller the warranty and the proof of purchase (a receipt).

The warranty does not cover transportation or post costs. During the period of the warranty, we will not cover damages and/or defects resulting from typical wear and tear. The warranty does not cover damage resulting from abuse, misuse, failure to follow operating instructions or incorrect maintenance by the purchaser or third parties. The warranty does not apply if alterations have been made to the original construction.

Visit us at: www.parkis.eu

Follow us on social media for more inspiration and ideas!



www.parkis.eu