

Excellence in seaming



**335**

Cylinder-bed sewing machine  
for industry and handcraft

# 335

Universal cylinder-bed machine for use in:  
Small leather goods, leather garments, upholstery, shoes, etc.

## Areas of Application:

- Working on tubular or pre-attached articles
- Standard sewing work on leather wear, bags and leathercraft articles
- Binding of shoes and leather wear with leather-, imitation leather- or textile tape
- Piping work on bags, suitcases and upholstery









## Features:

- Very good feeding properties due to the unison feed
- Excellent sewing quality with high performance and sewing reliability
- Precise and consistent stitch setting at large spectrum of materials/fabrics
- Very neat bindings, even inside and outside curves, thanks to the moving binder and tape is held close to the binding edge (subclass -17/01)
- Fewer bobbin changes due to the large hook (40% more bobbin capacity than standard hook)
- Rugged and durable machine construction - Easy to maintain machine concept
- The high top feed lift (7 mm) allows trouble-free sewing of thick materials and an easy sewing over cross seams
- Easy loading and unloading – even of bulky material – due to a high fabric clearance of 14 mm
- Distance of the front edge of the cylinder arm to the needle: 9 mm - Cylinder arm diameter: 51 mm
- Original PFAFF Industrial machines have an additional security label with several security features on the machine head. The advantage of this security label is the protection against growing product piracy.



PFAFF

Versions:

Type	Model								
		-900/52	-911/97**		-2/27	-6/01	-17/01-650/03	-39/21*	-40/64*
<b>335</b>	B				x	x	x	x*	x*
<b>335</b>	B	●	●	●	x	x	x	x*	x*

For portfolio work. A smaller version of the kit (part set is smooth). Ruler mounted on the forearm.

For general sewing. Standard form of the kit.

For binding operations, 90 ° tape feeder, attachment on swing-mounted carrier mounted (without binder).

For binding operations, both edges folded in, 90 ° tape feeder, attachment on swing-away carrier mounted.

Sewing in piping between two material plies, piping guide retractable, attachment fixed. Available as N 2.5 (stitch length max. 2.5 mm) or for max. stitch length of 4.5 mm.

Remarks:

- x Selectable sub-class
- \* Sub-class has to be ordered separately (Sample and fabric are required)
- \*\* with air filter/regulator for pneumatic devices (-925/03)

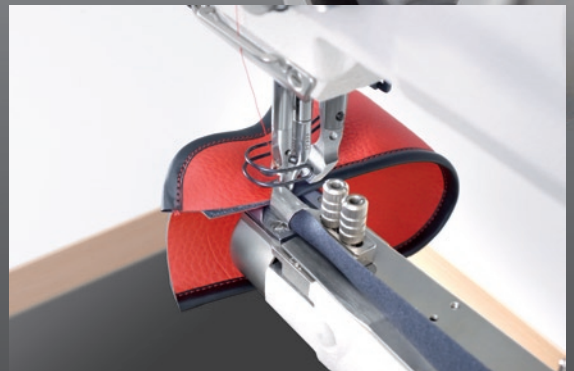

## Specifications:

**Stitchtype:**

301 (lockstitch)

**Max. sewing speed:**

2800/s.p.m.

**Max. stitch length:**

6 mm (N)

**Model:** B**Clearance under the sewing foot:**

max. 14 mm

**Top feed stroke:**

7 mm

**Clear work space:**

265 mm

**Clear work height:**

115 mm

**Cylinder bed dia:**

51 mm

**Cylinder bed circumf.:**

approx. 165 mm

**Needle system:**

134-35

**Needle thickness:**

80-100

**Thread type:**

synth. 40/3

**Balance wheel eff. dia:**

80 mm

**Working air pressure:**

6 bar

**Net weight (head):**

approx. 32 kg

**Net weight (head in carton):**

approx. 40 kg

**PFAFF Industriesysteme  
und Maschinen GmbH**

Hans-Geiger-Str. 12 – IG Nord

D-67661 Kaiserslautern

Telefon: +49-6301/3205-0

Telefax: +49-6301/3205-3171

E-mail: [info@pfaff-industrial.com](mailto:info@pfaff-industrial.com)

Website: [www.pfaff-industrial.com](http://www.pfaff-industrial.com)